

Oxfam Water Supply Scheme for Emergencies

This equipment is part of several packages devised by the Oxfam Public Health Engineering Team to help provide a reliable water supply for populations affected by conflict or natural disaster. The equipment is designed to be used with any or all of the following Oxfam water equipment: Water Storage equipment, Water Coagulation and Disinfection equipment, Water Pumping equipment, Water Distribution equipment, Well Digging equipment, and Water Testing Kit. All are designed using available, easily transported equipment which is simple, rapidly assembled, and fully self-contained, to provide an adequate, safe water supply at moderate cost. The principles used in these packages may often be useful in long-term development projects.

The Oxfam equipment packages, which consist of “Oxfam” tanks (steel sheets, rubber liners), diesel water pumps, 3” PVC pipes etc, have been used successfully in the last two decades in often harsh environments, ranging from tropical to temperate climatic areas. Although this equipment is designed for emergencies, if installed and protected adequately it can give many years of useful service, though some up-grading works will be necessary to prolong its life. This equipment can be dismantled and re-used elsewhere.

However, these Oxfam equipment packages, while being simple to erect over a period of days, yet durable enough to last several years, do not lend themselves to very rapid deployment in a few hours. Increasingly, the nature of work which Oxfam has been called on to undertake has required equipment that can be rapidly deployed then dismantled and moved to other locations. This has led to the development of the so called “rapid response kits” since the mid-1990s. This type of equipment is seen as a necessary complement to the original Oxfam equipment and is best used to provide a start up package in the absence of a detailed assessment and where affected populations are likely to be highly mobile. The relatively higher equipment costs and lack of suitability for anything other than short term water supply, means that the deployment of the “rapid response kits” should be used only where appropriate.

Read this manual through before starting installation.

Contents

SECTION A - EQUIPMENT USE AND SYSTEM DESIGN	2
Roughing filters	3
Slow sand filters	4
SECTION B – LIST OF KITS AND INSTRUCTIONS FOR USE	6
Water filtration kits	6
Tank siting	6
Roughing filter construction	8
Slow sand filter construction	12
SECTION C - COMMISSIONING AND OPERATIONAL INFORMATION	19
SECTION D – DETAILS OF KITS AND SUPPLIERS	25
Final reminders and recommendations, references and acknowledgements	

SECTION A - EQUIPMENT USE AND SYSTEM DESIGN

Wherever possible, water supplies in emergency conditions should be obtained from underground sources by exploitation of springs, tubewells, or dug wells. No filtration will then be needed. However, if sources are not available or cannot be developed, the use of surface water from streams, rivers, lakes or ponds becomes necessary. Usually these surface sources are polluted. The level of faecal contamination can be measured by use of the Oxfam/Delagua Water Test Kit (see Section C). Where a serious level of faecal pollution exists, it is essential firstly to try to reduce the cause of contamination, and secondly to treat the water to make it suitable for human consumption. The Filtration equipment provides a simple, long-term physical and biological treatment system that requires no chemicals (except small amounts of chlorine required during filter cleaning) and needs only simple regular maintenance.

The filtration equipment will enable a considerable improvement to be made in the quality of a polluted water source. However, it is essential that a suitable intake be constructed at the source to minimise the concentration of suspended solids in the water before it enters the treatment system. The well rings and pipes required for this are not included in these kits.

The filtration equipment uses the simplest form of water treatment, usually requiring no chemicals and relying on gravity to provide the flow through the system. It consists of settlement, roughing filtration and slow sand filtration. ***Water storage tanks for filters are not included in the slow sand or roughing filter kits. These should be ordered separately and allowance made for treated water storage too.*** If necessary, additional treatment of the water may be provided by chlorination. The treatment process and its effectiveness can be monitored by use of the Water Test Kit. Care is needed in the operation of this equipment, and a basic understanding of the physical and biological processes is useful in order to get the most out of it. An explanation of

these processes and the maintenance required is given in Section C.

Although some outline design data is provided below to give guidance in designing and setting up a suitable filtration system, it is very important to undertake basic water quality assessments. If the source is a river or stream, the quality will certainly vary from season to season and therefore measurements over a longer period of time will be necessary to determine the treatment requirements. However, given the time required to build filtration treatment plants (perhaps 2-3 weeks because of collecting, cleaning and placing media), this equipment would generally be appropriate for use in the post-emergency phase (after 6-12 months). Measurements can be taken during this period. For more detailed information on designing and operating a plant refer to "Surface Water Treatment by Roughing Filters" by Weglin.

SPHERE recommends a figure of 15 litres per person per day for water supply. This figure is based upon water requirements for drinking and food preparation, which require higher quality water, as well as water needed for clothes washing and bathing. Where nearby sources of water such as streams and rivers are available and the safe use of these for washing clothes and bathing can be managed, it may be appropriate and necessary to initially size the treatment system on a figure of 10 litres/person/day (as this manual assumes). This would provide the water required for food preparation and drinking (i.e. a minimum of 5 litres/person/day) while allowing for subsequent increased demand, perhaps due to population expansion. Given the time and effort required to set up such water treatment systems, it is appropriate to ensure there is ample capacity in the system.

Oxfam uses two basic types of filtration process for treatment of physically and microbiologically contaminated (surface) water:

1. Water (surface) with high physical contamination (which often has high microbiological contamination too), needs to be treated using roughing filters prior to being treated by slow sand filters. The primary function of roughing filters is to reduce physical contamination – although they do also have a limited ability to reduce microbiological contamination.

2. Water (surface) with low physical contamination (suspended solids) but with high microbiological contamination can be treated using slow sand filters alone. The primary function of slow sand filters is to eliminate microbiological contamination – they have limited ability to cope with high levels of physical contamination.

Note: physical contamination is caused by suspended solids, approximate estimates of which are made by measuring turbidity.

Roughing filters

The roughing filters kits are built in T11 tanks and designed so that the raw water flows upwards, which greatly improves their cleaning efficiency by using gravity to backwash accumulated solids built up in the filter. Efficiency is further improved by placing media on a raised floor with a void below it.

The number of roughing filters required depends upon raw water quality and required production capacity and this should be assessed/calculated and appropriate designs drawn up before construction starts. For optimum performance roughing filters should be run at a maximum surface-loading rate of $0.6 \text{ m}^3/\text{m}^2/\text{hour}$. (This throughput can be visualised as the average velocity at which water passes through the filter.) This means that each T11 tank should be run to produce $3.2\text{m}^3/\text{hour}$. They can be run at lower throughputs but there is little difference in percentage removal of suspended solids between 0.3 and $0.6 \text{ m}^3/\text{m}^2/\text{hr}$. However, the efficiency drops off above $0.6 \text{ m}^3/\text{m}^2/\text{hour}$. Flow meters have not been provided in this kit as they are prone to blockage with high suspended solids loading. Flow rates will need to be determined manually.

Roughing filters are often required to be built with a number in series (each tank being a stage), using progressively finer media in each tank. Raw water quality will determine how many stages, i.e. how many roughing filter tanks will be required: the more stages used (usually no more than three) the greater the cleaning effect on the water. If the water is fairly clean, a single-stage filter, or one with three different sized media layers in one tank, may suffice. Small scale pilot studies will indicate the best design of the system. Such trials should take into account seasonal variations in water quality.

As a guide, roughing filters should aim to produce water that is <20 NTU if water is then being passed through a slow sand filter or <5 NTU if it is to be disinfected with chlorine. Where different sized media are used, it is typical to select coarse, medium and fine sized media. These can be configured in one multi-layered roughing filter, or with one media size in each tank, giving a three-stage system. A roughing filter based upon three layers in one tank might look like this (with the coarsest layer on the bottom):

Media size	Grading	Depth of layer
5-10mm	Fine	300mm
10-15/20mm	Medium	300mm
15/20-25/30mm	Coarse	600mm

Note: care should be taken if using sharp-edged stones that the tank liner is not damaged.

The larger suspended particles in the water, and much of the finer ones, are removed by the coarse media layer. As this layer has the greatest volume of material to adsorb, it is the thickest of the three layers. If poor raw water quality requires the construction of a three-stage (i.e. three-tank) system, then the tanks should be constructed in series, using one media size in each tank. The coarse media tank is placed upstream.

Guidance on how many filters may be required can be drawn from the following:

A roughing filter built of three layers in one tank has a removal efficiency of 85% at $0.3\text{m}^3/\text{m}^2/\text{hour}$ and 75% at $0.6 \text{ m}^3/\text{m}^2/\text{hour}$. Three roughing filters

in series have a removal efficiency of 87-92% when operated at 0.3-0.6 m³/m²/hour (all for turbidity range 30-500 NTU).

Note: the above figures should be used as a rough guide only. True treatment requirements should always be determined by conducting pilot tests on the the actual raw water to be treated.

The design of the roughing filter will depend on the method used to treat the water against microbiological contamination before consumption. For example, three roughing filters in series will reduce suspended solids from 50 to 5 NTU, a level sufficiently low to allow chlorination, while a single multi-layer roughing filter will take water from 80 to 20 NTU, allowing treatment by slow sand filter.

A stable suspension with a large amount of organics, e.g. algae or colloidal matter or colour, may be difficult to treat with a roughing filter and will sometimes require the addition of coagulants (such as aluminium sulphate) upstream of the filter.

Having assessed the production requirement and undertaken the pilot study with the raw water in question, the appropriate media size(s) can be selected, the number of T11 tanks and roughing filter kits ordered and a system layout plan drawn up. Work can then proceed on construction.

Slow sand filters

Traditionally slow sand filters were built in T70 tanks with two filter lines in parallel, and the old Oxfam filtration kit was designed in this way. This allows a continuous water supply to be maintained, even while one of the filters is being cleaned. However, the more recent use of special geotextile filter fabric on top of the sand reduces the required cleaning intervals and the time taken for filters to recover their biological treatment ability. Therefore the old filter kits with two parallel lines have now been changed to have a single filter line (although it is still possible to order the

equipment required for the former set-up). This means the kit can now be considered for use with smaller community groupings, **provided that a regular supply of chlorine is available for disinfecting product water for the period immediately after filter cleaning when the filter is "recovering"**.

Additionally, the recommended filter throughput has been increased from the rather conservative 0.1m³/m²/hr to 0.2m³/m²/hr, which though increasing the required level of cleaning and the system head loss, is still well within standard slow sand filtration operation practice. These changes have all been introduced in order to make the capital investment in the slow sand filtration treatment kits more attractive, in order that there is a greater use of this very appropriate and sustainable technology.

The incoming water is usually pumped to the raw-water tank and then flows by gravity through the filter to the treated-water tank. Ideally the clean water should then be distributed to the users by gravity-fed pipeline.

When the unit is operating at the design rate, over 150,000 litres of water are produced over a 24-hour period, enough water for more than 15,000 people at 10 litres per person per day. The Slow Sand Filtration kit requires two Oxfam water storage tanks, one of which acts as a raw-water storage (3.0m high for 95m³ tank size) and one as the filter (2.3m high for the 70m³ tank size). These consist respectively of four and three rings of corrugated steel sheets, with a flexible synthetic rubber liner. The kit comes complete with all the necessary pipework and fittings for connection to a supply from a raw-water source and to treated-water storage tanks. The only materials which are required for this installation and which are not included in the kit are sand and gravel.

If operated correctly, the Slow Sand Filtration kit will considerably improve both the physical and bacteriological quality of slightly turbid water. Turbidity is generally much reduced by settlement in the raw-water storage tanks, and any residue is removed by the filters. (Settlement is effective for particles larger than about 0.02mm and particles

smaller than this in the “colloidal” size range will only be removed by roughing filters and/or slow sand filters.) However, the filters will be rapidly blocked by high turbidities. It is suggested that a practical upper limit of turbidity for the incoming water to the raw-water tanks is 20 NTU, although occasional levels above this, such as after heavy rain storms, may be tolerated. Alternatively a figure of no more than around 2-5mg/l of suspended solids should be permitted for the incoming water. Numbers of bacteria, viruses, and cysts, all potentially disease-causing microorganisms, are very substantially reduced by biological action within the filters.

Oxfam Water Storage tanks may also be required for treated water storage. It is useful to provide sufficient storage capacity in the treated-water tank to even out fluctuations in supply and demand. Normally people collect water in the early morning and late afternoon/evening. Water filtered overnight will often not be collected at that time and will need to be stored. As 75m³ of water will be produced in 12 hours at a filtration rate of 6,400 l/hr per filter, the storage volume will be at least 75m³ for a population of 15,000.

SECTION B – LIST OF KITS AND INSTRUCTIONS FOR USE

Water Filtration Kits

This section explains how to use/erect the following kits (detailed kit lists are provided in Section D):

The package of kits required to install a slow sand filtration system is:

Oxfam code	Description
FF	Filtration fittings kit
T95L	95m ³ tank liner and accessories
T95R	95m ³ tank roof
T95S	95m ³ tank steels
*T70L x 2	70m ³ tank liner and accessories
*T70R x 2	70m ³ tank roof
*T70S x 2	70m ³ tank steels

*T70 x 1 included for treated water storage

The package of kits required to install 2 roughing filters (required for each slow sand filter) is:

Oxfam code	Description
FRF x 2	Roughing filter kit
T11 x 2	11m ³ tank steels, liner and roof

Detailed lists of parts and erection instructions for the tanks can be found in Oxfam Water Storage Pack manuals, which are packed with each T11, T95L and T70L box.

Tank siting

1. The location of the treatment plant is usually dictated by conflicting parameters:

- elevation above the distribution area
- proximity to the distribution area
- proximity to the water source

Each situation will need a different solution, but the following criteria should be borne in mind when making the choice. Where possible, take advantage of natural slopes by locating tanks above the site to be served. Survey the site to establish likely distribution point locations, and work back from these to estimate the desirable filtration-system elevation for gravity distribution before setting up the tanks. It may be worthwhile constructing an elevated earth platform for the whole or part of the plant, in order to achieve gravity distribution on a site with little natural slope. A pump will usually be required to move water to the raw water tank and, if ground conditions dictate, from the final clean water storage tank into distribution. Pumps should not be used between raw water tanks, filters or final clean water tanks.

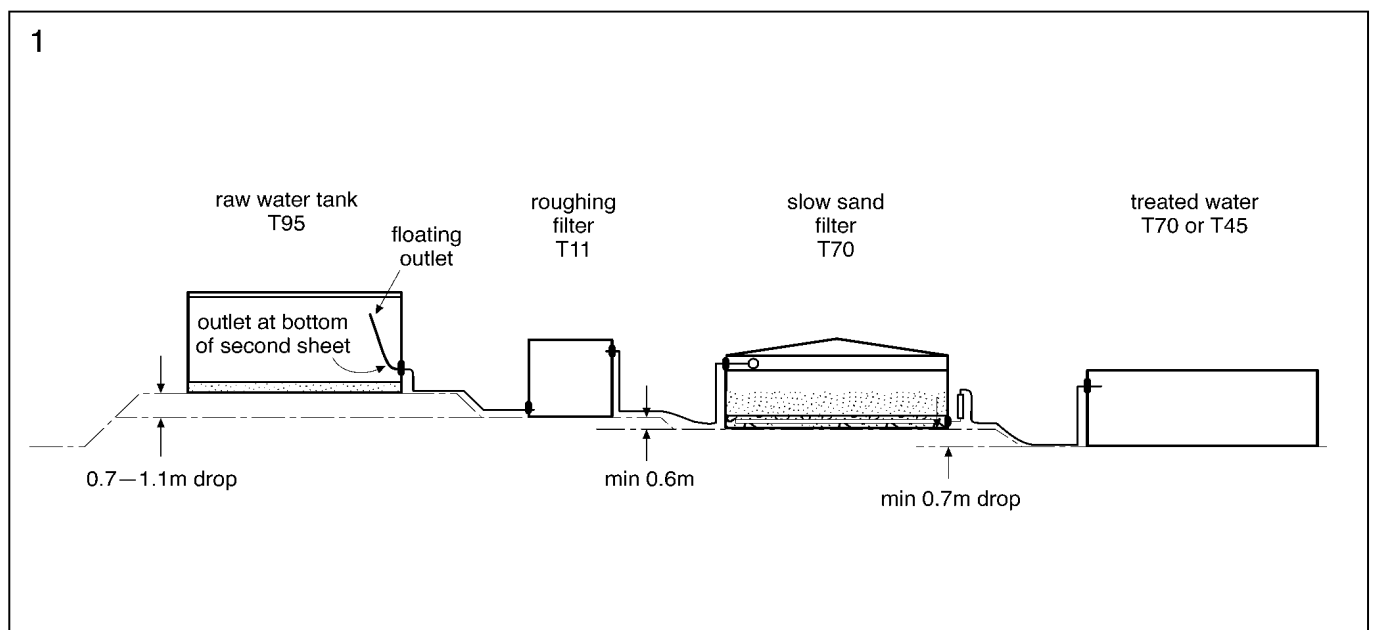

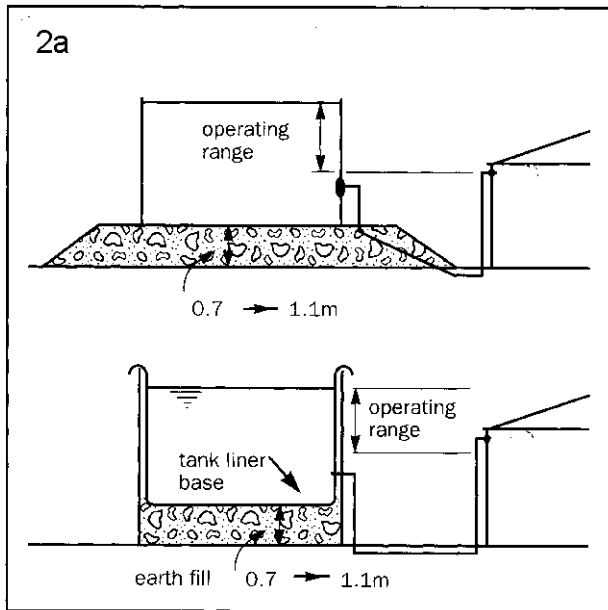

Although the weight of a full tank is relatively small, firm ground is necessary to avoid subsidence. In soft ground, take stringent precautions against subsidence caused by erosion of foundations or wind pressure. A gravel or concrete foundation ring may be necessary for long term installations, as well as a substantial earth bank around tanks. It may also be useful to put a ferrocement skim onto the inside and outside of the tank walls and base of the liner if the installations are likely to become permanent, but this perhaps could be considered only once the systems' use and functionality has been demonstrated over a period of time (see Storage manual).

A site well clear of trees is desirable in order to avoid problems of roots, falling branches, and canopy drip.

Tanks must be fenced and guarded against possible damage and contamination by the users.

2. Depending upon operational considerations, it is recommended that the base level of the raw-water tanks is set between 700mm and 1100mm above the base level of the roughing filter or slow sand filter tanks. This means that, when batch pumping for a filtration rate of 6,400 litres/hr (per filter), the pumps would need to be operated either three or four times per 24 hrs (see Section C, Daily Operation, for a more detailed explanation).

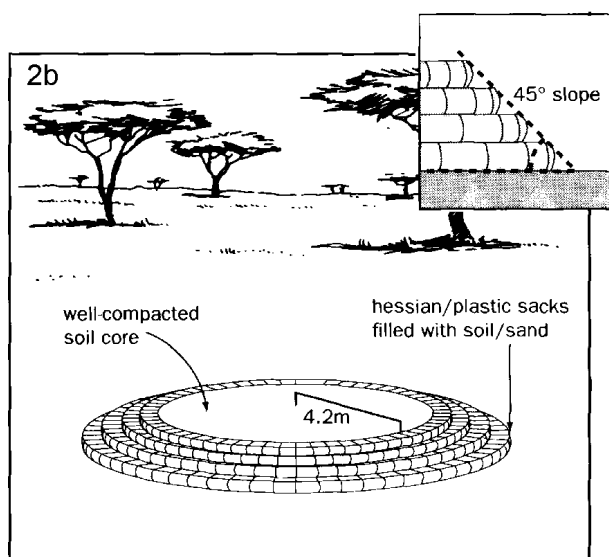

Each roughing filter stage should be 300mm higher than the next roughing filter stage and 600mm higher than the slow sand filter. On a flat site it may be necessary to construct a well-compacted earth mound, or to add an extra ring to the tanks, filling the bottom one with earth (additional tank sheets will need to be ordered), or excavate to achieve the desired level for the filters.

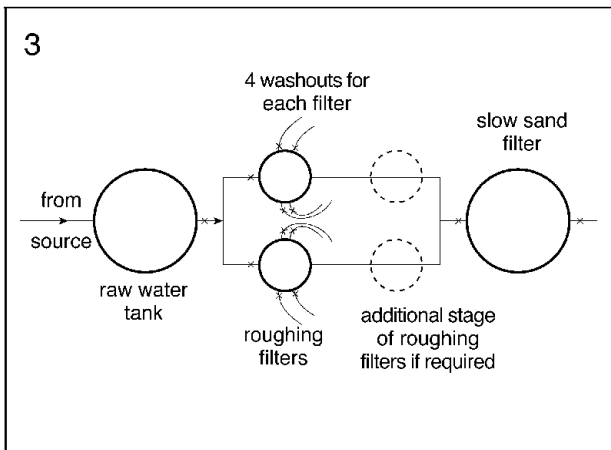

Roughing filter construction

This section deals solely with construction of roughing filters. Where roughing filters are required these can either be built in between SSF and raw water tanks, which are dealt with in the next section, or constructed for use in other treatment systems. The roughing filter kit and the instructions below relate to its use with the slow sand filter kit.

Suitable media should be identified and washed before any other work takes place. This is important as it can take many days/weeks to arrange if there are no suitable media sources available nearby. The selection of the media size and number of filters should be determined by the design process (see section A). Media can consist of gravel, broken stones or burnt clay bricks, **however care should be taken not to select laterite or any other iron bearing stone, as this will cause the filters to cement up and not function.** The shape or roughness of the material has little impact on cleaning efficiency. It is far more important to ensure that material is washed thoroughly and is free from organic material. Suitable drainage arrangements need to be made for regular disposal of wash water such that water sources are not contaminated, or that wash water erodes tank foundations. A sludge pit/soakaway would be one solution.

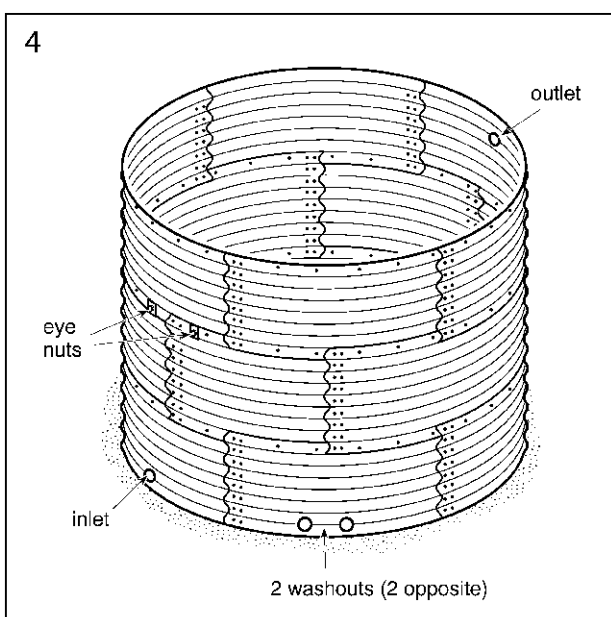

3. Where roughing filters are to be built as part of a slow sand filtration system, the layout of pipework and number of T11 tanks will need to be determined and these positions marked on the ground. The direction of washout pipes should also be established. Typically parallel lines of roughing filters will be required for each slow sand filter tank, each consisting of one or more roughing filter stages.

4. The roughing filter fittings kit is designed to build a roughing filter inside an Oxfam T11 tank (only the post 1996 versions, all of which are 2.6m in diameter and have the extra holes drilled in two of the tank sheets for additional outlets). It can either be built into an already erected T11 tank by cutting the liner to take the extra (washout) flanges, or put in once a new T11 tank has been erected. Erection instructions for the T11 tank should be followed (see

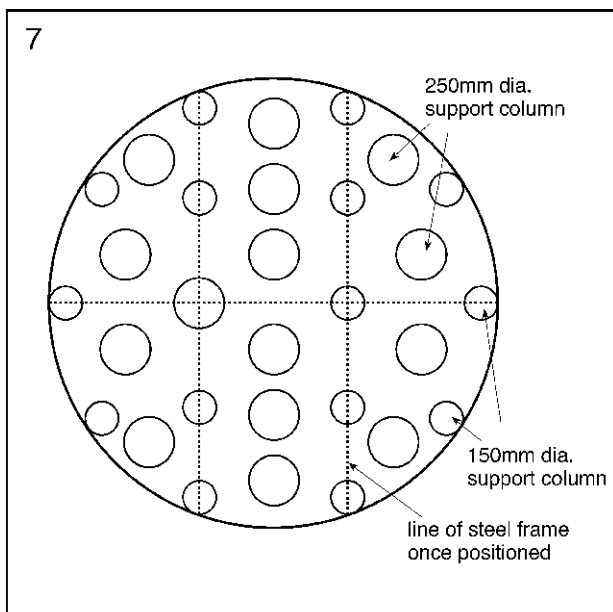
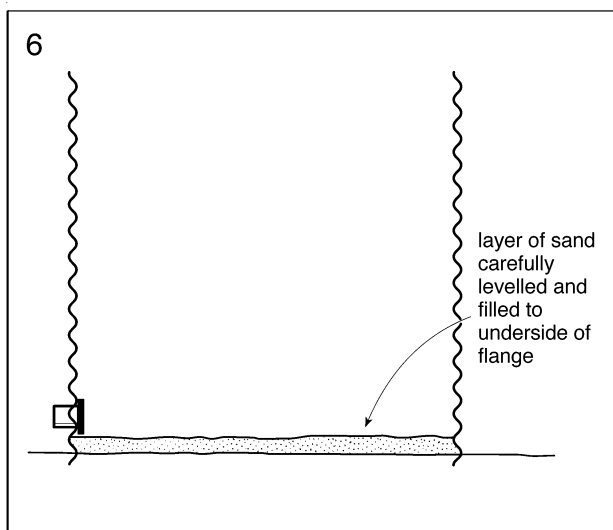
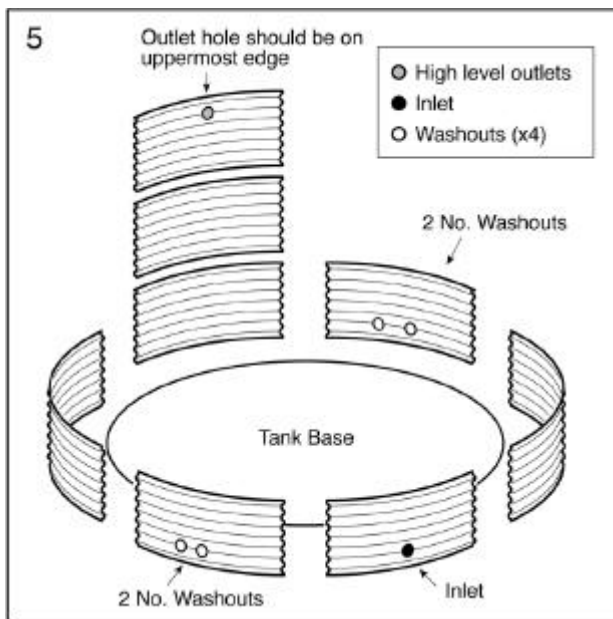

yellow Oxfam storage equipment manual) excepting a few small variations listed below.

5. The roughing filter is designed to have four outlets/washout valves and the two tank sheets with two blanked off holes should be positioned opposite each other with the holes at the bottom of the tank and such that they allow the most convenient disposal of wastewater. Three of the flanges and two 3" ball valves are supplied in the FRF kit, while the fourth flange and two more gate valves are available in the T11 tank kit for this purpose. The inlet flange in the T11 tank kit should be positioned in the sheet with a single hole in it, such that it is located at the bottom of the tank. Both the flange and the gate valve for this are provided as part of the T11 tank kit. The outlet flange should be located at the top of the tank in the most convenient position as required.

6. Before the liner is put up for the first time, the inside of the tank should be filled up with sand or soft soil (ensuring that there are no sharp stones in it) to a depth of about 50mm, or just below the bottom edge of the flanges. The sand should be carefully levelled. Where a roughing filter is being installed in a pre-erected tank, the liner may need to be dropped down inside the tank in order to take off any blanking plates covering holes in sheets and to position the additional flanges for washouts in the sheets. At this stage the opportunity should be taken to support the liner with sand/soil as explained above. This will ensure that the amount of water that is below the flange invert (lowest water draining point) is kept to a minimum. This permits more efficient desludging of the tank during flushing/cleaning operations.

7. Once the tank liner is in position, the sheet of PVC should then be laid out on the base of the liner. The base plates and columns, which come in two different sizes, should then be laid out according to the diagram and corresponding to the PVC sheet template showing column positions. Note that the larger columns are to be positioned away from the angle iron edges of the six sections of the raised floor.

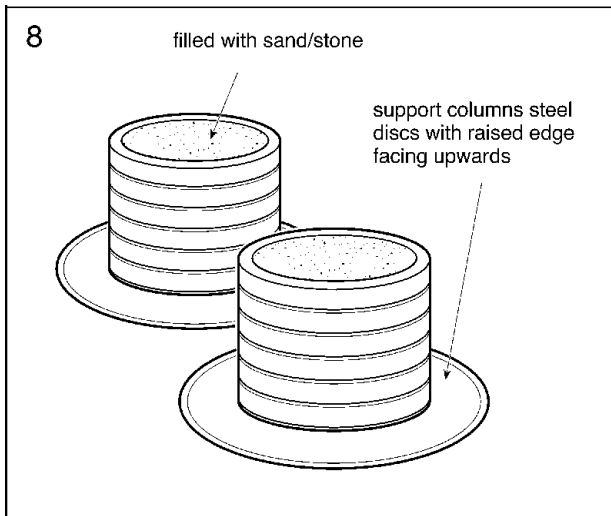

8. The columns are positioned on base plates (steel discs) with the raised edge facing upwards. This helps distribute weight and protect the liner. The columns should be filled to the brim with sand/stone to give additional strength to the structure.

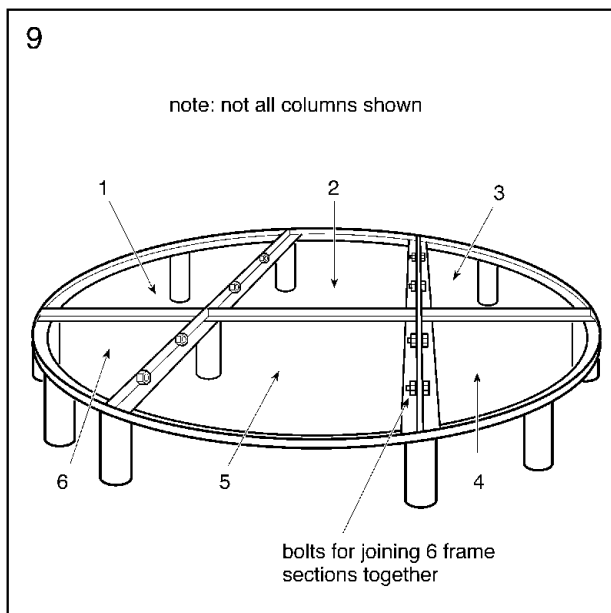

9. Five of the six sections of raised floor metal frame should then be carefully positioned on top of the columns one by one, leaving out one of the middle sections to allow a worker to stand in the space of the missing section. Care must be taken to ensure that the smaller columns are positioned underneath the joints and at the edge of the five sections of the raised floor to maximise the strength of the floor, which will have to carry a very large load. The sections of raised floor can then be bolted together.

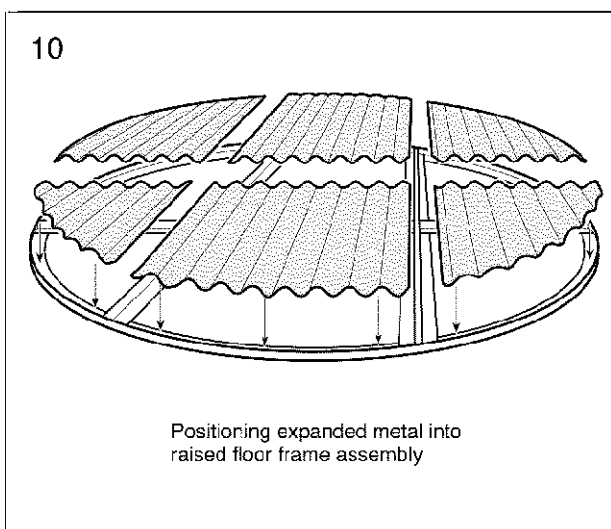

10. Some sections of corrugated expanded metal can be dropped into the corresponding frame sections. The last section can now be added while standing on top of the corrugated expanded metals and bolted in. The final section of corrugated expanded metal can now be positioned to complete the raised floor assembly.

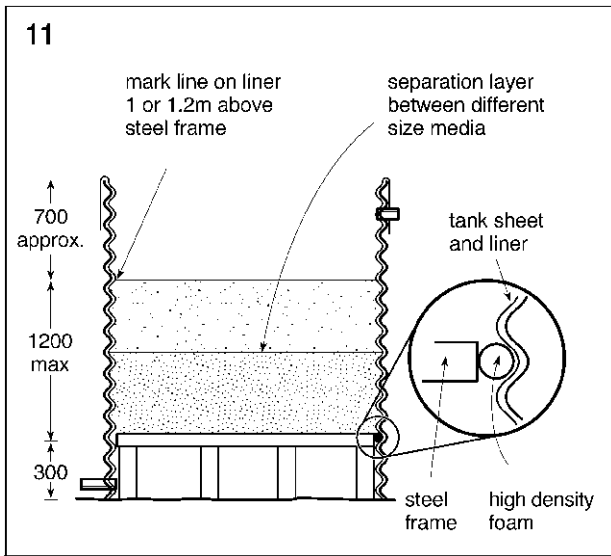

11. The 9m of high-density foam strip should be wedged between the corrugation and adjacent to the edge of the frame. This ensures that media will not drop down between the liner and the edge of the frame during initial filling and once some media has been introduced this will form a bridge between the liner and frame. A line should be marked around the liner at a distance above the raised floor of 1m (for single media size filter) or 1.2m (for multi layer filter). This will be used to determine the height to which the media should be filled. The selected media can then be put into the tank. Care should be taken in using sharp edged angular stone in the roughing filters as the sides of the liner may be punctured during filling with stone. Where a multi layer system is used, it could be useful to separate out the different media layers using a non woven fabric or wire mesh (not included in the kit), as this will prevent media from becoming mixed during manual cleaning operations when media has to be removed. Additional stones should not be added to take the media level higher, as the raised floor structure will not be strong enough and may collapse.

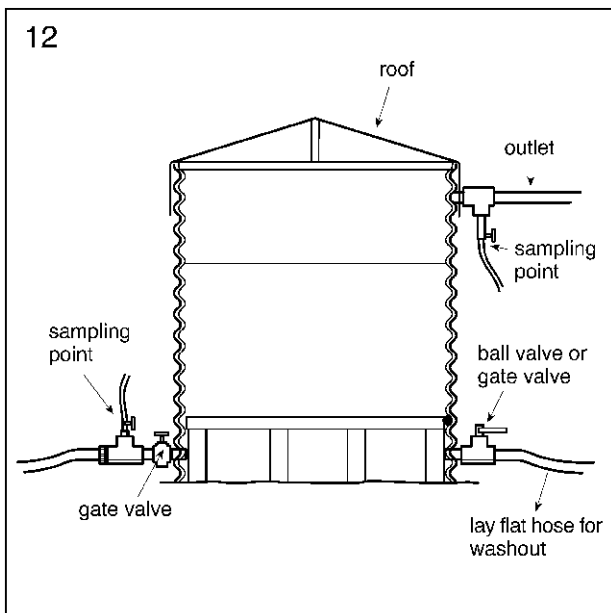

12. The roof should be added to cover the media in order to reduce algae build up. Finally a gate valve should be fitted to the inlet flange, and the two other gate valves and two ball valves should be fitted to the washout flanges. A drainage channel should be dug each side of the tank and to enable waste water from the washouts to run to a suitable soakaway and the layflat hose length cut to suit the position of the trench – 26m is provided in total for this. The kit includes Tees with sampling taps and hoses for inlet and outlets and these should be fitted as shown. These sampling taps will be used for monitoring water quality and filter performance

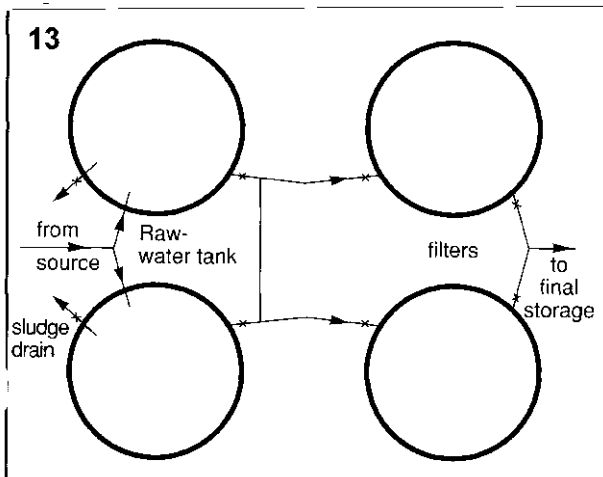

Slow sand filter construction

(Refer to yellow Oxfam Water Storage equipment manual for details on tank erection)

Note diagrams show layout of 2 parallel lines of slow sand filters as per the old kits. As the new kits consists of fittings for only one slow sand filter, the diagrams will not fully represent the way the pipework is set up unless two slow sand filter kits are used in parallel.

13. Study subsection on Interconnection Pipework, and decide on correct locations for inlets and outlets to tanks. Mark pipework layout on the ground with pegs to show inlets and outlets.

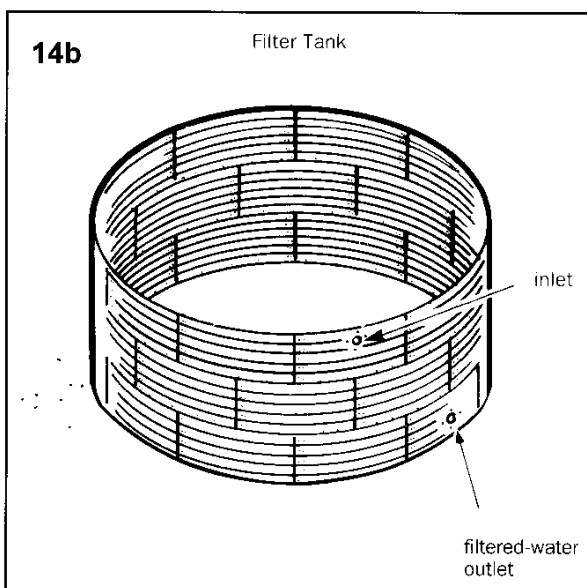
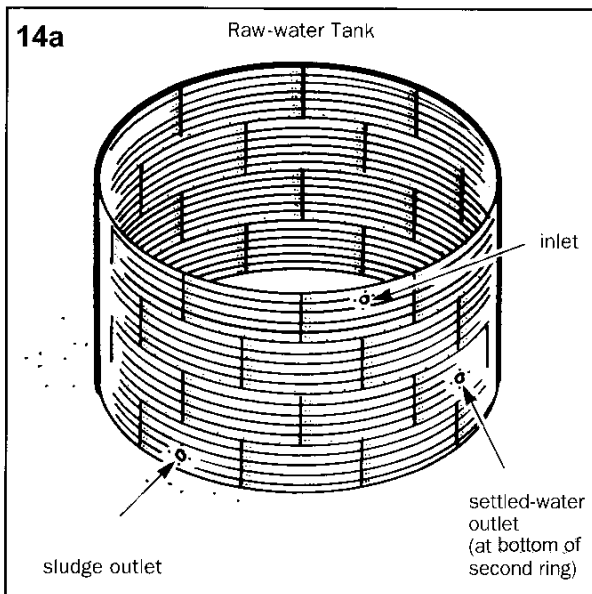

Erection of 2.3m-high filter tanks and 3.0m high raw-water tanks requires either a stepladder or a simple scaffold platform, neither of which is provided in the Pack. They can be ordered separately (codes OL, OT). It is possible to make use of empty fuel drums or the empty crates, which contained the tank liners, but ensure that any such improvised platform is stable.

(Do not attempt to erect these tanks in windy conditions) Even in calm conditions, no tank should be left empty without guy ropes to stabilise it. During construction, temporary guys can be run from the top of the tank to the ground; or, preferably, erection should be planned so that each tank is partially filled with water as soon as it is completed.

14. The erection procedures for the filtration tanks and the raw-water tanks are very similar. The only differences between the two types of tank are that the raw-water tanks are taller, having four rings instead of three, and that three connections can be made to the raw-water tanks. These are for inlet, settled-water outlet, and sludge outlet. The second of these is made by use of the blanked-off hole, which is in one of the sheets

Note: Do not complete connection for inlet to filters until the sand is positioned and the liner is in its final tensioned state.

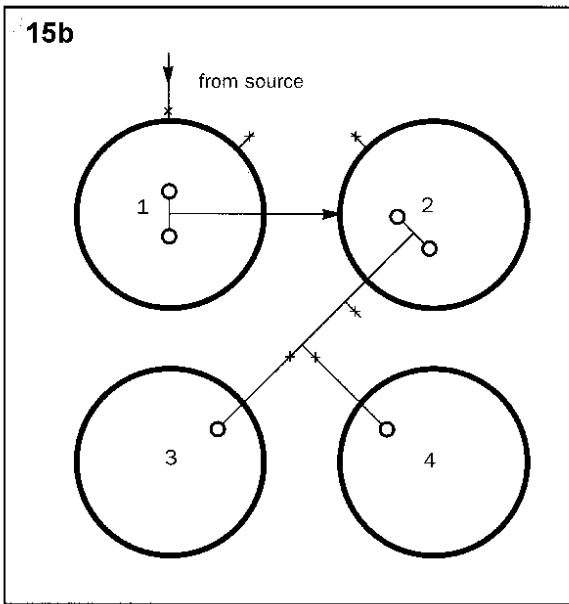

15b If turbidity is a particular problem, an alternative layout with raw-water tanks connected in series should enhance turbidity removal. However, this requires two raw water tanks, with tank No. 1 higher than tank No. 2 to permit gravity flow from one to the other. If the outlet of tank No. 1 is not slightly above the inlet of tank No. 2, the operating range of the raw-water tank will be reduced and operation of the system will be more complicated.

Raw-water tanks

Gate valves are provided to close off the sludge drain outlets. A length of hose should be connected to these when draining, in order to carry water away from the tanks.

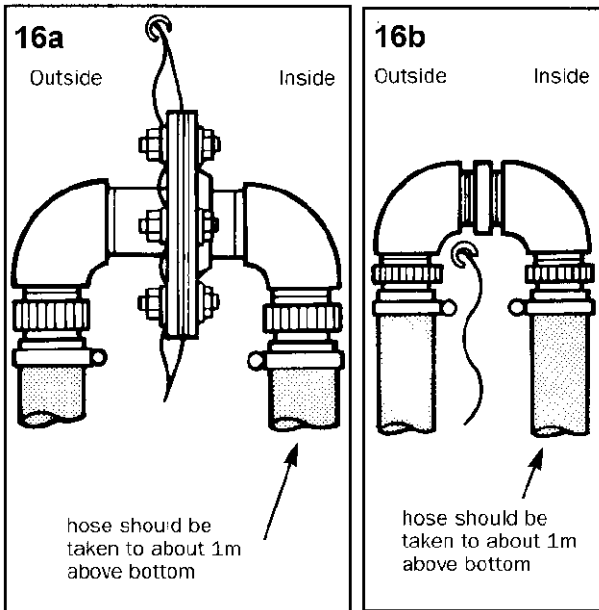

16. The inlet from the water source to the raw-water tanks may be connected in one of two ways:

- a) By attaching an elbow to the top flanged tank connector.
- b) By connecting two elbows together and hanging this assembly over the top edge of the tank.

In either way, gate valves should be provided at some point on the incoming pipelines, so that each tank can be isolated.

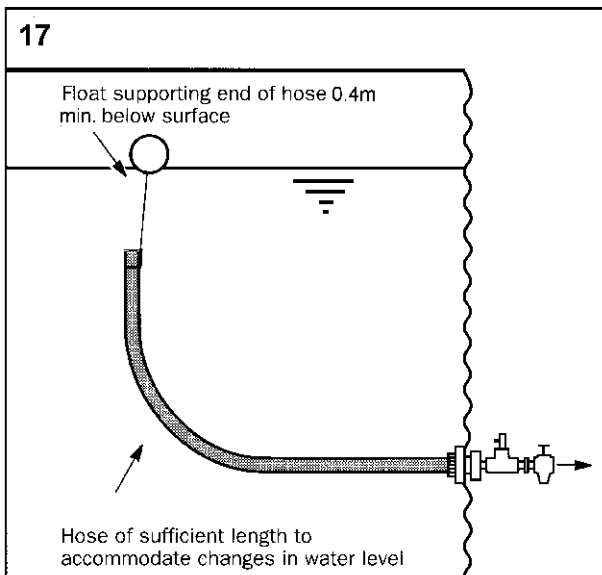

17. The removal of turbidity will also be increased by use of a floating outlet from the raw-water tank. The hose should be suspended no less than 0.4m below the water surface to maintain adequate flow.

Slow sand filter construction

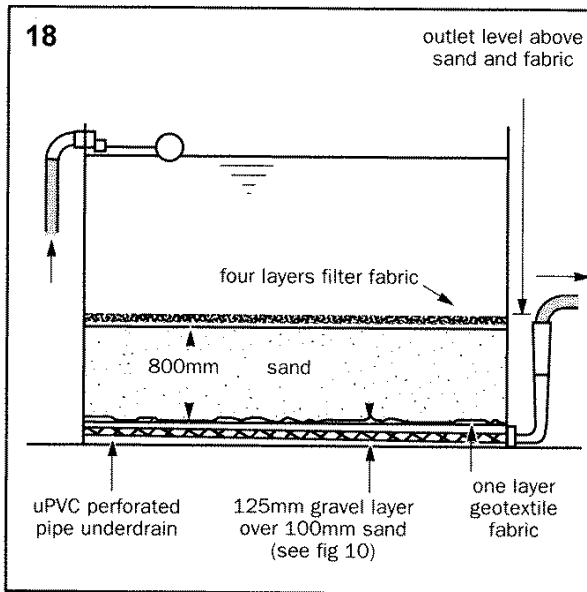

18. The filter consists of a 100mm layer of sand spread on the base of the tank, on which a network of perforated uPVC land drainage pipe is laid to collect the filtered water. This pipe is surrounded by a 125mm layer of gravel. Above this is placed one layer of geotextile fabric (2mm thick), on which the filter sand is placed to a depth of 800mm. This geotextile fabric is intended for separating the gravel and filter-sand. Four layers of another geotextile fabric are placed on top of the sand. The water level should be maintained at a depth of approx. 1.0m above the sand

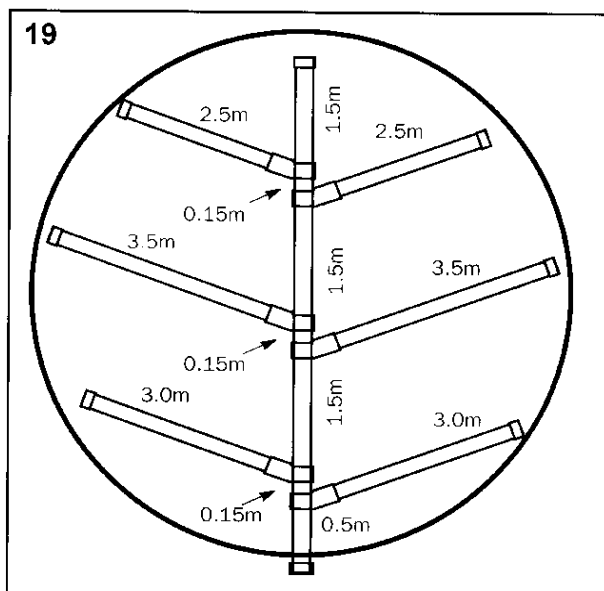

19. First cut the coil of perforated uPVC land-drainage pipe according to the layout shown here. Then spread a 100mm layer of any clean sand on the base of the tank and place the underdrain pipe on top of this. The pipes are simply pushed into the 67.5° equal junctions without sealing rings, as slight leakage through the joints is not a problem. All pipe ends are capped.

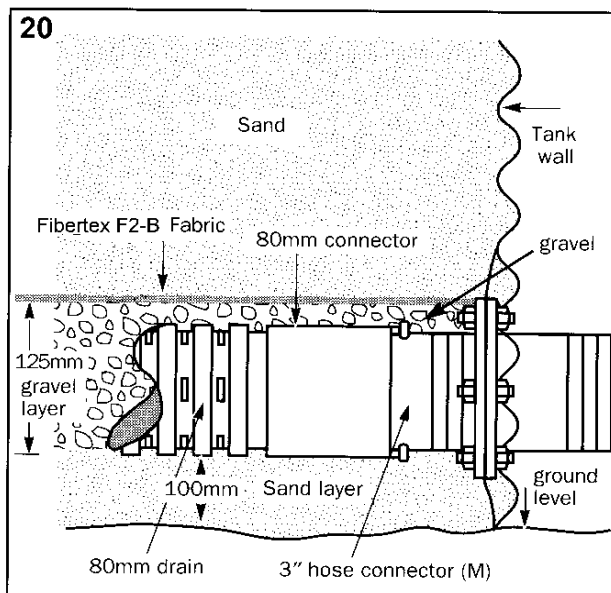

20. Connect the drain to the outlet by means of a 80mm connector, a 3" hose connector (M), and then to the threaded outlet flange. Completely surround the drain with a 125mm-thick layer of clean gravel sized between 5 and 25mm, and finally cover this with the geotextile fabric cut to suit. Wrapping the underdrain pipe with filter fabric is not recommended.

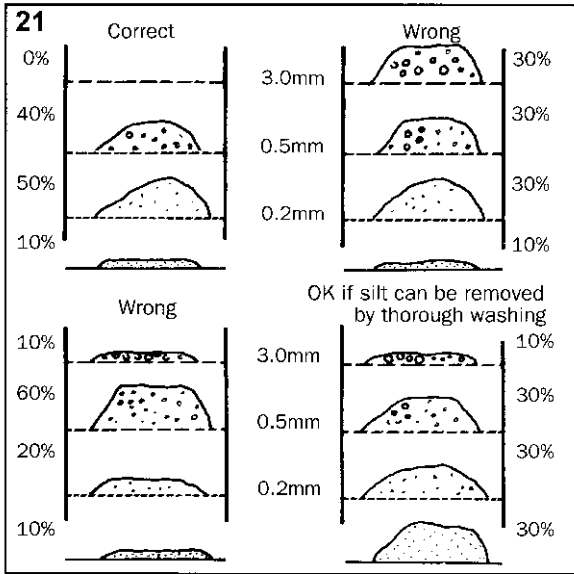

21. While the tanks are being erected, a suitable source of filter sand should have been located and transported to the site. The careful selection and grading of sand is not as critical as for rapid filters. However, the sand should be relatively coarse and uniform for maximum porosity (uniformity coefficient $UC < 2$):

- maximum size 3mm diameter (\emptyset)
- minimum size 0.1mm \emptyset
- effective size (sieve size through which 10% of sand passes) between 0.15mm and 0.35mm
- Uniformity coefficient UC (\emptyset 60% size divided by \emptyset 10% size), is between 2 and 3.

A good builder's grade sand is ideal.

Test representative samples of naturally occurring sands by first washing to remove fines, silt, and organic material. Then dry and sieve the sample through the stack of sieves provided (3.0mm, 0.5mm and 0.2mm). If approximately equal quantities are retained on the 0.2mm and 0.5mm sieves, the sand is acceptable. If a large majority of the sample is retained on either of the 0.2mm or 0.5mm sieves, the sand should be rejected. If a large proportion passes through the 0.2mm sieve, this small material should be removed by careful washing, but such sand should be avoided if possible. It is necessary to sieve only a sample, not all the sand for the filters.

(NB: Ensure that sand does not contain excessive iron, which will complicate the treatment process)

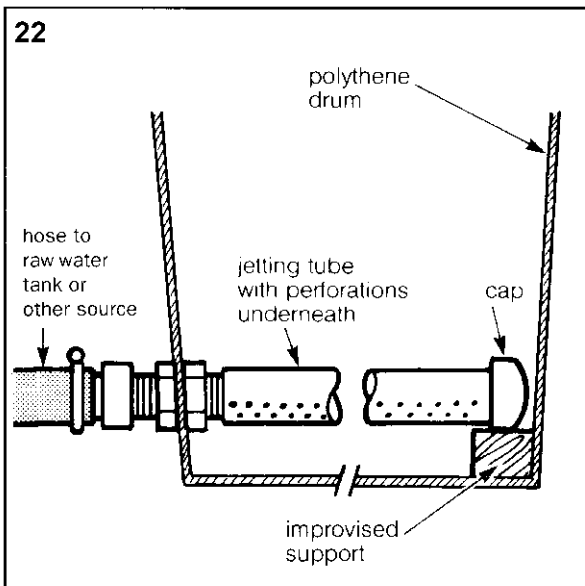

22. All naturally occurring sands need to be washed to remove fines, silt and organic contamination before use in filters. A total volume of 27.5m³ of washed sand is needed for a filter. Washing is carried out using the drum provided, taking water from the nearly full raw-water tank or any other pressurised water source. First assemble the jetting tube in the bottom of the drum, as shown. Connect this to the tank outlet, using a 3" hose and connectors.

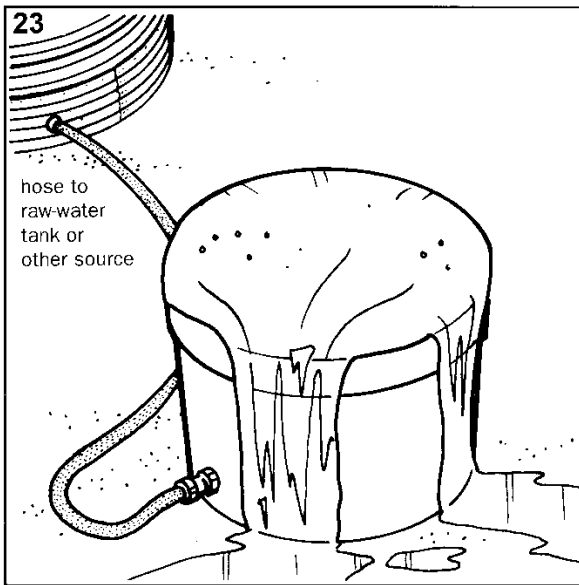

23. Ensure that excess water will drain away from the tanks. Fill drum to the brim with sand and level off. Slowly open valve at the tank outlet to allow water to flow into the drum, fluidise the sand, and so carry the silt upwards and away in the overflow. Open valve fully and allow to flow for about five minutes, or until overflow appears clear. If a large proportion of original sand has been removed, top up and wash again, in order to conserve water.

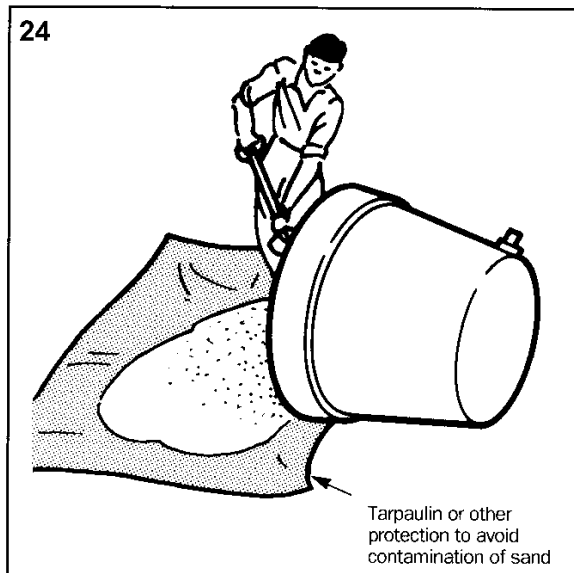

24. Disconnect hose from drum and allow water to drain out. Shovel the first half of clean sand out of the drum and tip the remainder out. Avoid contact between the clean sand and the ground (tarpaulin provided).

Before filling a filter with sand, fill with water to well above the outlet flange, in order to check for any leaks.

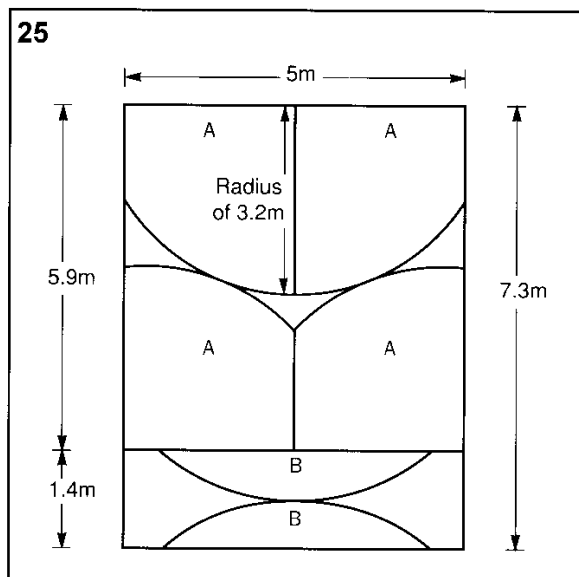

25. Fill filter to a depth of 800mm of sand. This will take a long time and much labour, if done entirely by hand. When this is complete and the surface has been levelled off, four layers of filter fabric are placed on the surface of the sand. The fabric is supplied, cut roughly to the cutting pattern, from 100m long rolls, 5m wide.

Any further cutting should be done using a sharp knife, with the fabric laid out on a clean hard surface, to the exact shape of the tank.

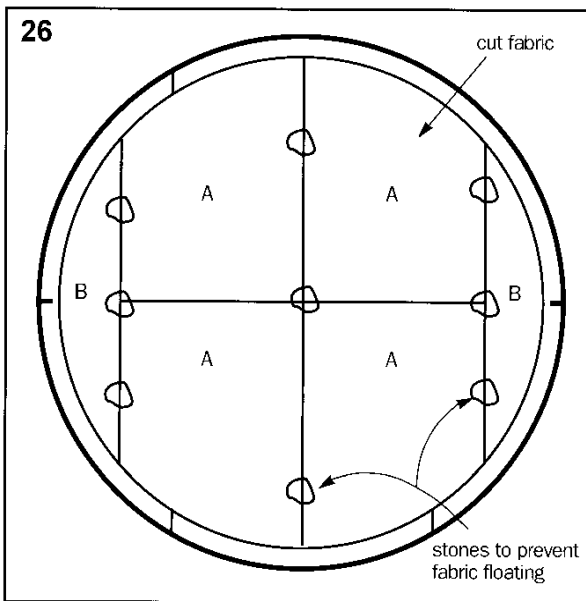

26. Each of the four layers of fabric comprises six pieces. The layers should have cut joints, staggered by rotating each subsequent layer 45° horizontally relative to the one below. The number of layers depends upon the quality of water, turbidity in particular. More layers may be necessary to maximise filter run-time, but these would need to be ordered separately. When laid on the sand, the fabric must be weighted down, particularly at the joints, with pieces of stone of sufficient size to prevent the fabric floating when the filter is filled with water.

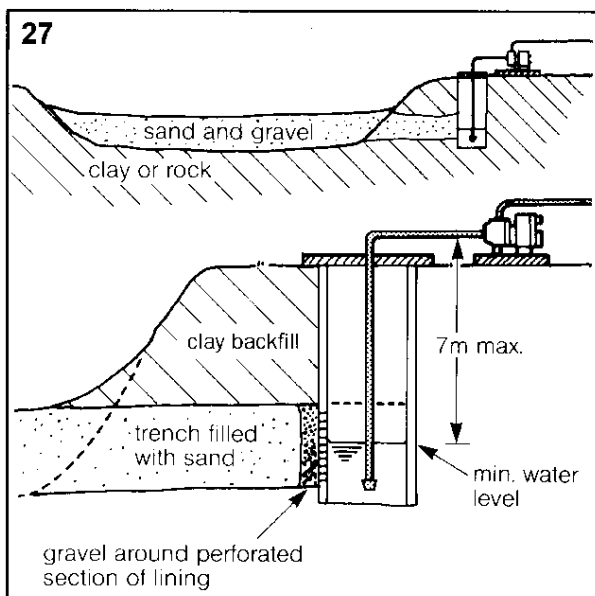

Use of infiltration galleries

Often the best way of exploiting a surface water source, and one that improves both the physical and microbiological quality, is by taking water from the sediments found in a riverbed. This method will yield water even when there is none evident on the stream surface, as much is stored in the sediments. Two methods are illustrated here:

27. By construction of a well in the riverbank which is surrounded by gravel and connected to the porous river sediments by a sand-filled channel.

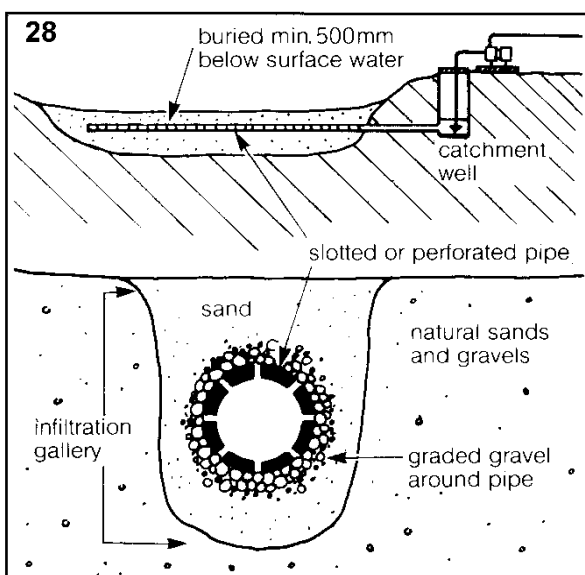

28. By use of a slotted or perforated pipe laid under the riverbed. The pipe is surrounded by graded gravel and sand and collects water from both the surface and the sediments. (Note: gravel and sand back-fill should be free of iron, otherwise the treatment process will be complicated.) It leads water to a collection chamber in the riverbank, from which it is pumped. The yield may be increased by construction of a sub-surface dam, a wall across the riverbed, which blocks the sub-surface flow, downstream from the infiltration gallery. Such a dam will also protect the pipe from movement.

SECTION C - COMMISSIONING & OPERATIONAL INFORMATION

Roughing filter commissioning and operation

Roughing filters perform optimally at a throughput (velocity) of 0.6m/hr, i.e. equivalent to a production capacity of 3.2m³/hr for a T11 tank. Flow control through filters should either be by floating constant head outlet in the raw water tank or by the gate valve at the tank inlet. (A flow meter is not provided as part of the kit as it is prone to blockages where suspended solids loading is high.)

The tank should be filled bottom up (as it will be operated) in order to force out trapped air. When it is first run, water should be allowed to run to waste for half an hour or so to allow the system to stabilise. Similarly, after the system has been sitting idle for a time, there will probably be some (excessive) solids carry over and this can be run to waste. However it is preferable to run roughing filters as a continuous process rather than on a batch basis, as they operate more efficiently like this, both in terms of production output and also in terms of product water quality. Roughing filters may take as long as one month before they bed down fully. The roughing filter should not be allowed to dry out during continuous operation unless it is cleaned in advance. Drying out is unlikely to occur as the outlet is at the top of the tank, but if it does, flush the tank a few times with influent water in order to wash out the settled solids.

The frequency of roughing filter cleaning will be determined by local circumstances, but the units are generally reliable whether high or low levels of deposition have taken place within the media. The frequency of cleaning operations also has little effect on overall performance. The following is suggested as a guide for determining the frequency of cleaning operations before local knowledge has been developed.

Mean raw water turbidity (NTU)	Initial roughing filter cleaning frequency (days)
<25	20
25-100	10
100-500	5
500-800	2
>800	daily

Also, high levels of organic matter call for more frequent cleaning. Cleaning frequency will have to be determined by actual experience, though care should be taken not to “overclean”, as there will be a loss of biological efficiency of the filter. Cleaning is performed by closing the inlet valve and then opening all four outlet valves simultaneously to achieve maximum backwash velocities, i.e. the tank should be emptied out as quickly as possible to scour out as much of the settled solids as possible. The layflat hose attached to the washout valves should be carefully laid out so it does not have excessively tight bends or kinks in it, as this will considerably slow the rate at which the tank can be emptied.

As a minimum, the T11 tank should be able to empty in 4 minutes or better still in 2 minutes to achieve the correct washout velocity (the cleaning velocity needs to be 30m/hr or ideally 60-90m/hr). This may not be achievable with just four washout valves at the bottom of the tank, so consideration may need to be given to using a pump to add clean water into the top of the tank during emptying to maintain the head of water in the tank to ensure sufficient scour is achieved. There should be a complete manual cleaning every 1-5 years. The head loss in a roughing filter should be in the region of 200-300mm. If this is exceeded greatly this is also an indicator that the filter should be cleaned. Measuring how much dirt is left in the backflush water is a useful way of monitoring the effectiveness of the backwash regime.

organisms on or near the surface of the sand filter. Soon after the start of the treatment process, a film of these biologically active micro-organisms develops in the filter fabric and the top of the sand. This film breaks down the incoming disease-carrying organisms, converting them into water, carbon dioxide, and other harmless chemicals. At the same time a large amount of suspended matter (which causes the cloudy or 'dirty' look of the water) is retained in the fabric and sand by simple straining.

The continuous straining process will gradually block the pores in both fabric and sand, which allow the water to pass through. This is shown by a lowering of the water level in the head-loss indicator tube on the outside of the filter tank, while the water level above the sand remains the same. In order to maintain the same flow through the filter, it is necessary to open the outlet valve further. After a certain time (generally 3-12 weeks, depending on raw-water quality), the valve will be fully open and the filter will be so blocked that it is no longer possible to get enough clean water out of it. It is then necessary to clean the filter (see below).

The following factors are important for satisfactory operation:

1. The surface of the filter fabric must never be exposed to the air while in operation. It must always be submerged in water, preferably to a depth of 1.0m.
2. There should be a continuous flow of water through the filter at a rate, as uniform as possible, of not more than 6,400 litres per hour. If the flow through the filter stops for more than a very short period, the biological cleaning process will very rapidly cease, though flows of 10% of the required output are adequate to keep the filters functional. The capacity of treated-water storage should therefore be sufficient to balance peaks in demand. If the flow through the filter increases rapidly, debris will be flushed out of the filter into the treated water and reduce water quality.

The active microbiological layer on the surface of the filter takes some time to become established and effective. It is partially removed in cleaning the filter. Therefore filtering is not as effective for a short time after cleaning.

Daily Operation

At a filtration rate of 6,400 litres per hour per filter, the water level in the raw-water tanks will drop at 0.2m/hr. If they are not filled up, the water level in the filters will drop at the same rate, but flow will cease before the water surface reaches the fabric, as the outlet pipe is constructed above this level. If there is a difference in base level between the raw-water tank and filter tank of 700mm, then it will be necessary to fill the tanks only four times each day. This could be done by running the pumps on an operation schedule such as the following:

Time to start filling raw water tank	Volume of water to be pumped m ³
00.00 hrs	38.4
06.00 hrs	38.4
12.00 hrs	38.4
18.00 hrs	38.4

This means that water in the raw-water tank will sediment for 6 hours less pumping time. If there is a difference in base level between the raw-water tank and the filter tank of 1100mm, then it will be necessary to fill the tank only three times each day. However if the tanks are constructed on the same base level as the filters, it would be necessary to fill the raw-water tank every 4 hours in order to maintain a flow into the filters, which would present major problems with arranging pump operation throughout the night. This would also mean that sedimentation time would be reduced, with the result that inlet water into the filter would be poorer quality.

Filter cleaning

When it is no longer possible to obtain the required output and the outlet valve is fully open, it is necessary to clean the filter. This situation

arises when the filter fabric and the sand become progressively more blocked and head loss increases. Usually there will be about 0.3m head loss in the filter, but when it gets to 0.8m then this will be excessive. Filter runs between cleaning depend upon water quality, but may range from 3 to 12 weeks.

The whole cleaning and re-establishment process takes about three days, during which time arrangements should be made to chlorinate the product water until testing shows that the microbiological filtration process has reestablished itself. Where two filters are used in parallel and they are becoming blocked at the same time, the first one must be cleaned several days before the other is likely to become unusable. Though the initial ripening of a SSF takes about 2 – 4 weeks, cleaned filters should re-ripen in 2 – 4 days if the cleaning has been completed in 6 – 12 hours.

30. The cleaning process is as follows (refer also to diagram 29):

1. Close valve C1 on inlet to filter. Close valve F1. Connect 20mm hose to valve D1 and direct end of hose well away from tanks. Open valve D1 and drain water from filter, until water level is 200mm below surface of sand, as indicated in head-loss indicator tube. Close valve D1.
2. Enter filter tank with care, using timber boards to spread weight. Remove stones and weights

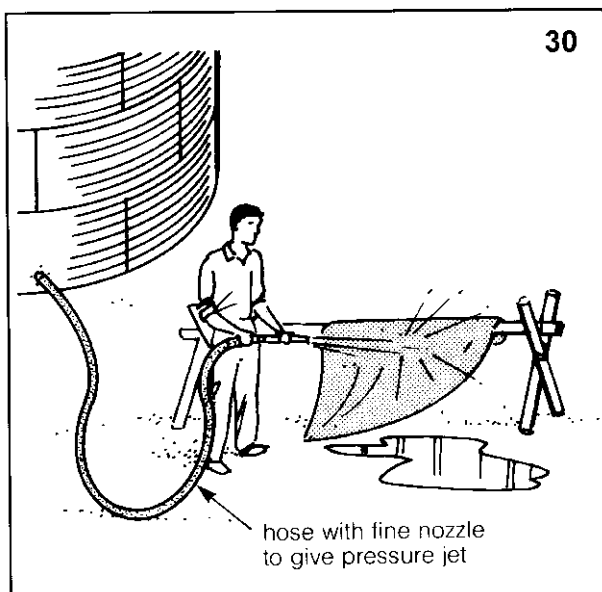

from filter fabric. Roll up fabric strips and remove all four layers from tank. Treat fabric with care and it will last for a long time.

3. Wash fabric by draping sheets over a support, and spraying with a powerful jet until all silt is removed. A short hose may be connected to the raw-water tank outlet A or, preferably, a pumped supply can be used for this washing.

4. In some conditions, and in all filters occasionally, it will also be necessary to remove a thin layer of sand from the surface of the filter, as this becomes blocked both with inorganic debris and with microorganisms. Avoid doing this until it is essential for satisfactory operation. Use flat-bottomed shovels to remove only about 10mm of sand, taking great care not to damage the tank liner.

5. Replace the filter fabric as before, weighting down with stones.

6. Refill the filter sand by back filling with water via the outlet valve and underdrain, preferably with clean water. When water level is above the fabric, open valve C1 and close D1.

7. While filter microbiology is being re-established, the filtered water will not be pure and it may be slightly turbid. Therefore disconnect filter outlet hose from the storage tank and allow it to flow to waste for a few hours or until any turbidity has cleared.

8. Reconnect to the storage tank and open valve F gradually over a period of 24 hours, until a flow of 6,400 litres per hour is indicated on the meter. This is particularly important if some of the sand has been removed, as this harbours most of the 'good' microorganisms. **Ensure that the filtered water is chlorinated if being used for drinking and after two days, or when the filtered-water quality test shows it to be satisfactory, cease chlorination.**

Eventually, after several years' operation, the sand thickness in filters may have been reduced to 500mm. This is the minimum for effective filtering. At this stage, more washed sand should be added and the full microbiological commissioning repeated.

If the raw water contains a large amount of suspended solids, this will be deposited in the raw-water tanks. As this builds up, it should be removed from the base of the tanks by simply

opening the bottom outlet, with a hose connected to take the sludge away from the tank foundations. If the sludge is too thick to flow through the outlet, it may be necessary to drain down most of the overlying water and mix the sludge by jetting with water.

Note: Sunshine may encourage the growth of algae in the transparent flow meters. This can be avoided by covering the meter with a cloth or a piece of 4" Ø pipe.

In order to monitor the functioning and effectiveness of the system, it is useful to record some measurements on a regular basis. A suggested table has been prepared which includes columns for turbidity, chlorine residual (if used), and faecal coliform measurements (which do not need to be made on a daily basis and not at all if there is a chlorine residual greater than 0.2 – 0.3mg/l).

Water monitoring

The use of water (quantity) meters (not included in the kit) on the outlet of the slow sand filters might be considered for monitoring total plant production. The flow meters provided can of course be used to indirectly measure the output and this should be recorded on a record sheet of some form.

The Oxfam/DelAgua portable water-testing kit is an essential tool for water-quality monitoring and is of particular use where a Filtration Pack has been installed. The kit is fully self-contained in an easily carried and rugged case weighting about 8kg, and comes with all materials necessary for several hundred tests. It can therefore be used in remote, rural situations. A form has been included to use in monitoring.

The kit is fully equipped to monitor the following four parameters:

- Faecal coliform count: this is the indicator of faecal contamination, the main source of water-borne disease. It is measured by means of membrane filtration and a battery-operated incubator.
- Turbidity: the degree of cloudiness and concentration of solids. Measured by a visual tube method.
- pH: acidity/alkalinity measured by colour comparator
- Chlorine concentration measured by colour comparator

Training in the use of the kit is essential in order to achieve valid results.

SECTION D – DETAILS OF KITS AND SUPPLIERS

Full list of kit contents

Slow sand filtration fitting kit

Oxfam Code FF

(approx. gross weight and volume: 3251kg, 2.0m³), containing:

Item	Qty	Description
1.	4	3" Ø BSP (F) tee GS (1 spare)
2.	6	3" Ø BSP (F) 90° elbows GS (2 spare)
3.	11	3" Ø BSP (M) hex nipples GS (2 spare)
4.	4	3" Ø BSP (F) hose coupling malleable iron (2 spare)
5.	9	3" Ø BSP (M) hose coupling malleable iron (1 spare)
6.	15	3" bolted hose clips (86-91mm) (4 spare)
7.	2	3" Ø BSP (F) caps GS (spare)
8.	1	3" Ø BSP (F) socket GS (spare)
9.	3	3" Ø BSP (F) brass ball valves
10.	2	3" (F) x 2 ½" (F) Ø BSP reducing bushes GS
11.	2	3" (M) x 2" (F) Ø BSP reducing bushes GS
12.	25m	3" Ø reinforced flexible plastic hose
13.	1	2" Ø BSP (F) socket GS (spare)
14.	1	3" Ø BSP (M) pipe 350mm long, GS, threaded both ends
15.	2	2" (M) x ½" (F) Ø BSP reducing bushes GS
16.	1	2 ½" Ø BSP (F) variable area float flow meter, flow 2,000 - 20,000 litre/hr
17.	1	2" Ø BSP (M) brass float valve c/w 8" plastic float
18.	10m	19/25mm Ø reinforced transparent flexible plastic hose
19.	4	Jubilee clips for 20mm hose (16-25mm)
20.	3	½" Ø BSP (M) brass ball cocks with 20mm hose tail (1 spare)
21.	1	½" Ø BSP (F) tee, GS
22.	1	½" Ø BSP (M) hex nipple, GS
23.	5	12m rolls PTFE tape (12mm wide)
24.	1	8" Ø ball float with screwed eyelets
25.	4	Complete circles of Fibertex F-4m Fabric cut in 6 pieces

Underdrain:

26.	25m	80mm Ø perforated uPVC land drainage pipe in coil
27.	6	80mm Ø 67½° equal junction
28.	7	80mm Ø end cap
29.	1	80mm Ø connector
30.	1	5m x 8m piece filter fabric - Fibertex Geotextile F-2B cut into 6 pieces

Sandwashing:

31.	1	4m x 4m G245 tarpaulin (approx 15 oz per sq. yard)
32.	1	500 litre heavy-duty plastic tank (Aqua flex AX100)
33.	1	800mm length 2" Ø plastic barrel nipple perforated with 5mm holes and threaded one end
34.	1	2" Ø plain end cap, uPVC
35.	2	2" Ø backnuts, GS, c/w 2 gaskets
36.	1	Set of three interlocking sieves 100mm Ø, mesh size 0.2, 0.5 and 3.0mm, c/w lid and receiver pan
37.	1	Oxfam Manual, 'Water Filtration Equipment' placed in grip-seal bag

Roughing filter for T11 tank

Oxfam code FRF

(approx. gross weight and volume: 258kg, 1.33m³)

Item	Qty	Description
1.	6	Pieces of expanded metal sheeting, covered in a plastic coating, with corrugations (corrugations to be same profile as Oxfam tank sheets), mesh size 23.1mm x 5.8mm, 1.5mm thick, welded onto metal frame.
2.	6	Sections of angle iron frame made from mild steel 50 x 50 x 6mm angle iron with combined shape to form circle of 2.54m diameter (to fit 2.6m diameter Oxfam T11 tank).
3.	48	M10 x 20mm bolts and nuts for bolting angle iron frame together
4.	15	300mm long floor, 250mm OD French drain support pillars
5.	15	300mm long floor, 150mm OD French drain support pillars to be nested inside 250mm OD pipes above for transit purposes.
6.	15	260mm dia. galvanised base plates, for drain support pillars, with edges turned up (to avoid damage to liner)
7.	15	230mm dia galvanised base plates, for drain support pillars, with edges turned up (to avoid damage to liner)
8.	9m	Length of high density foam insulation, circular cross section 50mm diameter
9.	2	3" Ø BSP (F) brass ball valves
10.	3	3" (F) threaded flange, 4 holes drilled for bolts (not threaded), Table D/E.
11.	3	3" Table D/E flange welded to 90mm long 3" Ø pipe threaded 40mm. 4 holes drilled for M16 bolts and 4 holes threaded for M16 studs. Weld shoulder not to exceed 6mm x 6mm.
12.	12	M16 Ø steel studs 100mm long each complete with 2 x M16 Hex full nuts and 2

13.	6	x M16 washers Type B (thin). 3" Ø BS Table D/E full face synthetic rubber gaskets with 4 holes.
14.	1	2.8m Ø uPVC flat plastic sheet (material as per T10 tank roof) with positions of column supports and the angle iron frame indicated on it by marker pen..

For sampling points on inlet and outlet

15.	1	3" BSP hex nipples GS
16.	2	3" BSP F to ½" M reducing Tee GS
17.	2	½" BSP F brass ball valve sampling tap
18.	2	½" BSP M to ½" brass hosetail connector
19.	2m	½" dia. hose to fit over hosetail connector

For connection into Oxfam Slow sand filtration kit

20.	1	3" BSP Tee F GS
21.	7	3" Ø BSP (M) hose coupling malleable iron
22.	2	3" Ø BSP (F) hose coupling malleable iron
23.	9	3" bolted hose clips (86-91mm)
24.	2	3" Ø BSP (M) hex nipples GS
25.	10m	3" Ø reinforced flexible plastic hose, code G3.15
26.	26m	75mm layflat hose

1 No 95,000 litre raw-water tank kit, comprising:

Code T95S – Tank Sheets

(approx. gross weight and volume: 502kg, 1.6m³).

Code T95L – Tank liner and accessories

(approx. gross weight and volume: 390kg, 1.1m³)

Code T95R – Tank roof

(approx. gross weight and volume: 120kg, 0.8m³)

2 No 70,000 litre filter and product water storage tank kits, each comprising:

Code T70S – Tank sheets

(approx. gross weight and volume: 390kg, 1.5m³)

Code T70L – Tank liner and accessories

(approx. gross weight and volume: 269kg, 0.8m³)

Code T70R – Tank roof

(approx. gross weight and volume: 116kg, 0.7m³)

2 No 11,000 litre filter storage tank kits, each comprising:

Code T11 – Tank sheets liner and accessories

(approx. gross weight and volume: 350 kg, 1.1 m³)

Optional equipment

Scaffold (3.7m high)

Code OS

(approx. gross weight and volume: 52kg, 0.5m³),

Ladder (2.4m long extending to 4.2m)

Code OL

(approx. gross weight and volume: 14kg, 0.18m³),

Delagua Test kit

Code FK

(approx. gross weight and volume: 15kg, 0.11m³),

Re-ordering

If it is necessary to reorder individual items, please describe as specified in the above list and quote name and code of the kit in which the item occurs.

List of Suppliers (based in the United Kingdom)

The water storage tanks are supplied by:

Butyl Products Ltd, 11 Radford Crescent, Billericay, Essex, CM12 0DW.

Tel (0)277 653 281, Fax (0)277 657 921.

Evenproducts Ltd, Oxtalls Farm Evesham, Worcs, WR11 4TS.

Tel (0)386 41212, Fax (0)386 765404

The Filtration Fittings Kit, Code FF, and Roughing Filter kit, Code FRF is supplied by:

Evenproducts Ltd (as above)

The Water Testing Kit, Code DK, is supplied by:

Roben Institute of Health and Safety, University of Surrey, Guildford, Surrey, GU2 5XH.

Tel (0)483 509209, Fax (0)483 503517