



# Build a biogas generator

## Key question

- How can we make and collect flammable methane?

Biogas is the name given to the gas that can be collected from decaying biomass. It is a mixture of about 60 per cent methane, 40 per cent carbon dioxide and trace amounts of hydrogen sulphide and nitrogen.

Building a biogas generator is simple and the diagram below shows you how to set one up. When your generator is complete, you will need to fill it with feedstock: this is the biomass that bacteria will break down to produce biogas.

When preparing and adding your feedstock to the generator you must wear rubber gloves, goggles and an apron.

## Setting up your generator

- 1:** Fill the bottle, which you will use as your generator, about 3/4 full with distilled water. Measure and record this volume. Empty this water into a bucket.
- 2:** Decide what feedstock(s) you are going to use in your generator, then carefully measure them out and record the weights.
- 3:** Add your feedstock to the water and stir it in carefully, breaking up any lumps so that it will pour through the neck of your bottle.
- 4:** When your feedstock looks like a fairly runny soup, carefully use a funnel to pour it into the generator bottle.
- 5:** Put the top on the bottle. Make sure that the end of the glass tube in the bung is NOT covered by the feedstock.
- 6:** Cover the bottle in black paper or plastic to prevent algae from growing inside.
- 7:** Leave your bottle somewhere warm for a month to six weeks.
- 8:** During the time it takes your generator to start producing methane, you need to find answers to the following questions.

- a:** How will I measure how much methane has been produced?
- b:** How could I test to see if the gas produced is methane?

The end of this tube must be ABOVE the level of the feedstock

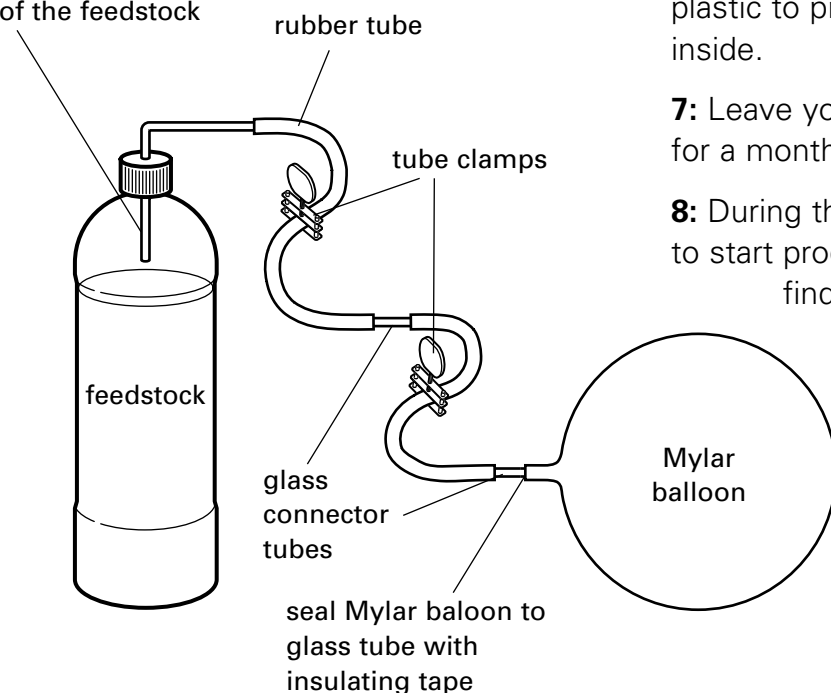



# Recording information about your biogas generator

**1:** Date of building your generator

**2:** Feedstock information

Description of feedstock	Weight used (g)

**3:** Volume of water used (litres)

**4:** We used distilled water instead of tap water because...

**5:** We wrapped the generator in black paper/plastic because...

**6:** Results

Date of checking gas produced	
Volume of gas produced (litres)	
Was the gas flammable? (yes/no)	
Did the gas smell? (yes/no)	



# Build a hydroelectric power plant

## Key question

### ■ Can we use water to generate electricity?

Hydroelectric power plants generate electricity from the gravitational potential energy of water. They do this by forcing water to flow through a turbine which is connected to a generator.

The diagram below shows a simple version that you can build for yourself.

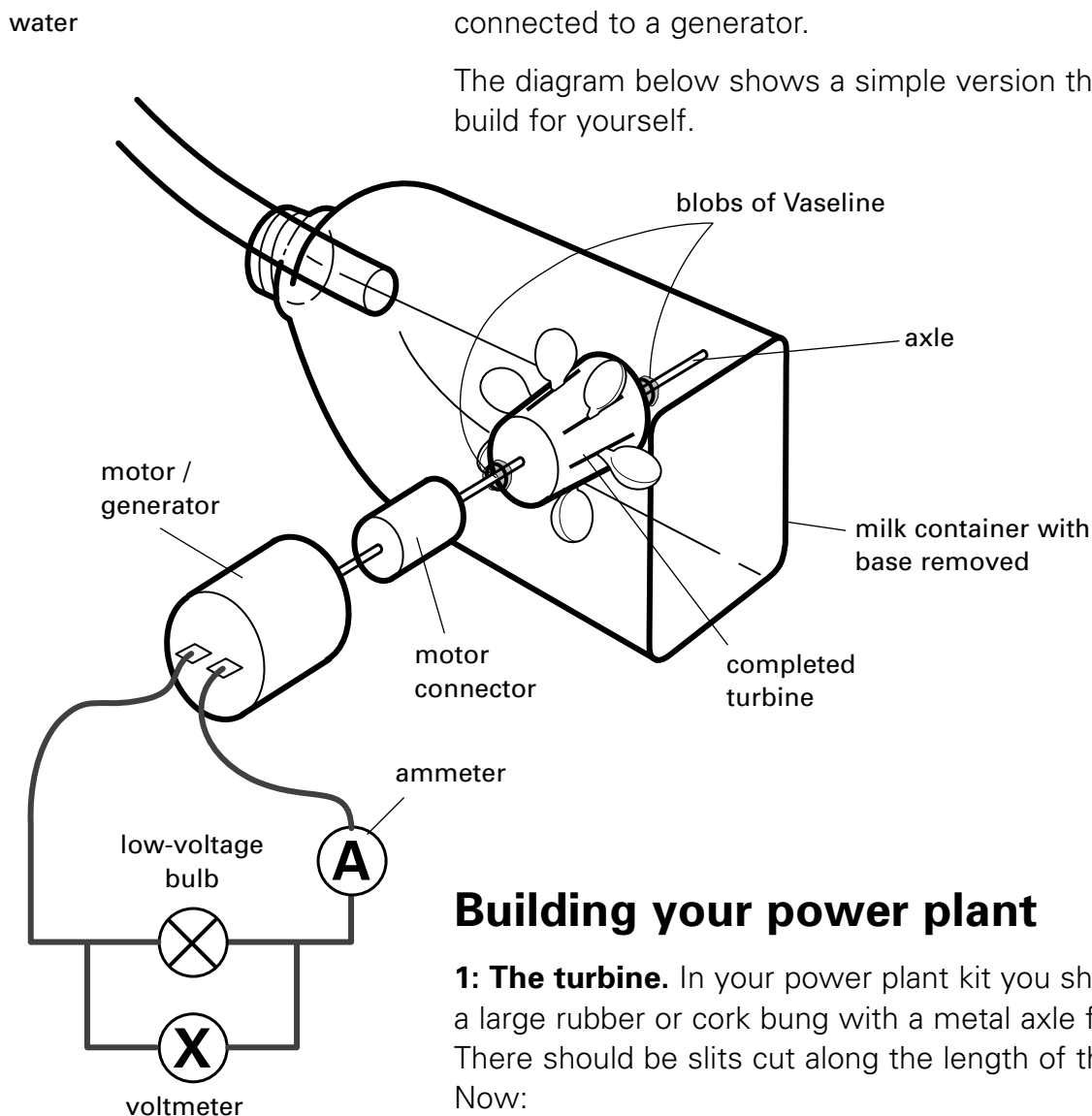

## Building your power plant

**1: The turbine.** In your power plant kit you should have a large rubber or cork bung with a metal axle fitted. There should be slits cut along the length of the bung. Now:

- a:** Cut the handles off some plastic spoons about 1cm from the bowl end (1 or 2 for each slit, depending on the size of your bung).
- b:** Push these spoon heads into the bung. You now have a model of a type of turbine called a Pelton wheel.



## 2: Attaching the generator

- a:** Cut the base off a 2-litre plastic milk bottle.
- b:** Carefully make holes in the sides, as shown in the diagram above, for the axle to pass through. These holes must not be too big or water will leak out, and they must not be too small or energy will be lost through friction between the axle and milk bottle.
- c:** Insert your turbine into the milk bottle and slide the axle through the holes.
- d:** Push a generator-axle joining block onto the axle. Push the generator shaft into the other side of the joining block.
- e:** Set up a retort stand and clamp to support the generator and turbine.
- f:** Add a blob of Vaseline inside the milk bottle to each hole where the axle passes through. This will provide lubrication and help to stop water leaking out.

## 3: Connecting the circuit

- a:** Connect a low-voltage bulb or LED to the generator.
- b:** Connect a voltmeter in parallel with the bulb/LED.
- c:** Connect an ammeter in series with the bulb/LED.

Your hydroelectric power plant is now ready for operation.



# Using your hydroelectric power plant

## Key question

- Does the height of the water running through a turbine affect the voltage level of a power plant?

The electrical power produced by your power plant will depend on the energy of the water that runs through it. This experiment will investigate the relationship between the gravitational potential energy of the water and the electrical power produced by the generator.

## Set up

**1:** Set up your generator so that the water that passes through it can escape into a drain, sink or bucket without spilling. Make sure that there is a mop nearby to clear up any accidental spillages. Check that the electrical circuit attached to the generator will not get wet.

**2:** Fill a bucket approximately half full of water and use a hose to siphon water from the bucket down through the generator. The set-up is shown below.

Do not suck water through the hose. Instead, use the following procedure.

- Run some water through the hose from a tap.
- Put your thumb over the end and let the hose fill up.
- When the hose is full, put your thumb over the other end.
- Place one end under the water in the bucket and the other end through the top of the milk bottle.
- For the siphon to work, the end of the hose in the bucket must be higher than the end of the hose in the milk bottle. Now remove your thumbs from the tube.

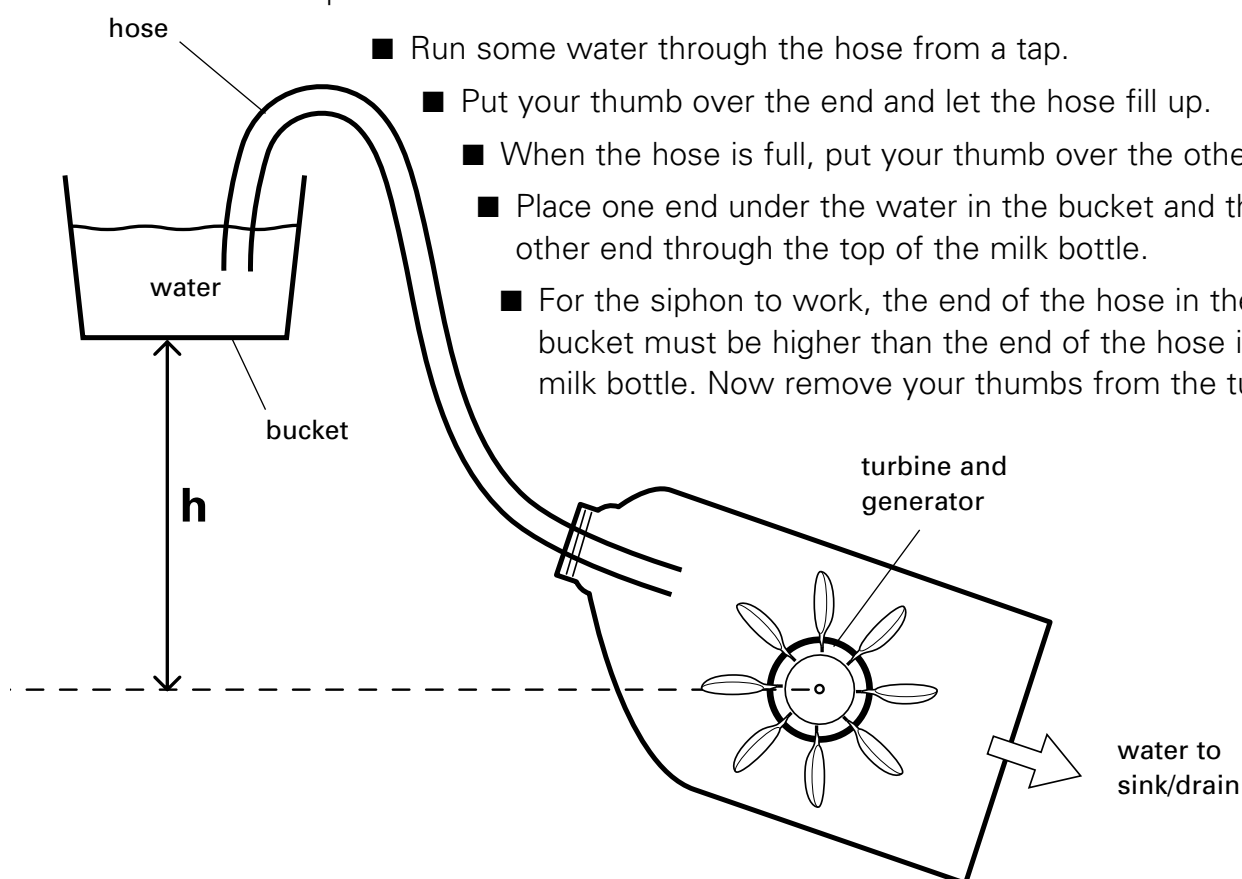



## Doing the experiment

**3:** Once everything is set up, you will need to measure the following.

- a:** The height ( $h$ ) of the bucket above the level of the turbine in metres.
- b:** The voltage ( $V$ ) produced by the generator in volts.
- c:** The current ( $I$ ) produced by the generator in amps.

Repeat these readings for at least five different heights. If you have time, take several readings for each height so that an average can be found. Organise your data in a table.

**4:** Once you have taken your readings, plot a graph of voltage ( $V$ ) against height of water ( $h$ ). You can also add another scale onto your graph to plot current ( $I$ ) against height of water ( $h$ ).

**5:** What does this tell you about the relationship between electrical energy produced and the gravitational potential energy of the water?



# Make your own anemometer

## Key question

- Can we measure the speed of the wind using simple everyday objects? Where would be the best place to put a wind turbine at school?

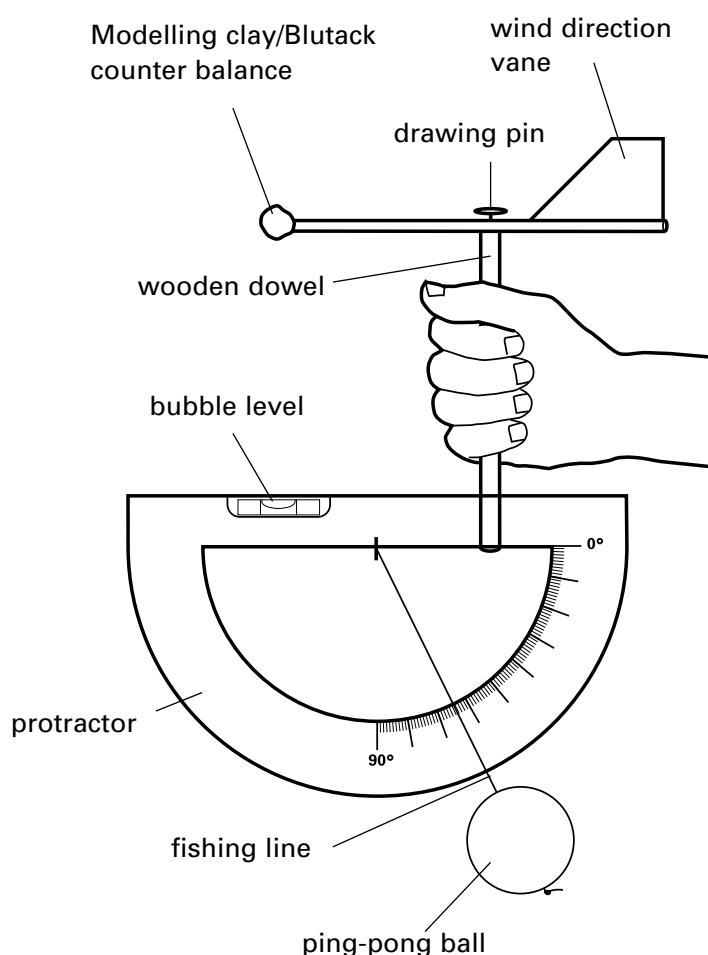

An anemometer is a device for measuring wind speed. The diagram and instructions below show you how to make a simple type of anemometer.

## How to build your anemometer

- 1:** Using a needle, carefully make a hole right through the centre of a ping-pong ball. Thread a 30cm-length of fishing line through this hole.
- 2:** Using a hot glue gun, glue the free end of the fishing line to the centre spot of the protractor.
- 3:** Lay the protractor on a piece of paper and push the flat edge up against a level surface, like a flat block of wood.
- 4:** Put a blob of glue from the hot glue gun onto the protractor where the bubble level needs to go, against the flat edge.
- 5:** Push the bubble level into the glue and up against the flat surface. It is important that the bubble level is fixed to the protractor as level as possible.
- 6:** Cut out the parts for your wind direction vane from some stiff card as shown in the diagram below.

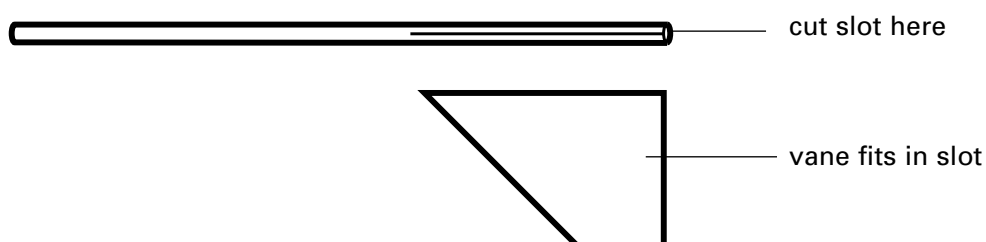



**7:** Using a drawing pin, fix the vane to the top of your piece of dowel. Make sure that the vane can move freely and that it is balanced on the top of the dowel.

**8:** Push the protractor into the slot in the base of the dowel and, once it is in the correct position, fix it with the hot glue gun.

**9:** Hold up your anemometer and check that the wind vane is balanced and moving freely. If it is not balanced, add some modelling clay or Bluetack to the bottom of it until it does balance.

Your anemometer is now complete, so how do you use it?

## Using your anemometer

Your anemometer works because any wind will push against your ping-pong ball and cause the fishing line to make an angle with the protractor: the stronger the wind, the bigger the angle.

**1:** To use your anemometer, hold the wooden dowel and see which way the wind is blowing by looking at the wind vane. Turn and face into the wind and check the bubble level to make sure that the anemometer is level.

**2:** Once the anemometer is level, look at the angle the fishing line is making on the protractor. Make a note of this angle and look it up on the table below. This table helps you to convert the angles made by your fishing line and ping-pong ball into wind speeds.

Angle made by fishing line and ping-pong ball	Wind speed (kilometres per hour)
90°	0
85°	9
80°	13
75°	16
70°	19
65°	22
60°	24
55°	26
50°	29
45°	32
40°	34
35°	38
30°	42
25°	46
20°	52





# Build a wind turbine

## Key question

- How can we harness wind energy to power machines at home and at school?

Wind turbines generate electricity by using the power of the wind to spin a generator. The diagrams and instructions below show you how you can build a simple version yourself.

## Building your wind turbine

**1:** Cut out two pieces of corruglute. These should be rectangular and slightly bigger than the motor you will use as your generator (50 x 30mm should be the right size). It is important that one piece of corruglute has the channels running across its width and the other piece has the channels running along its length.

**Note:** it is important that the channels in the corruglute bases are running in the direction shown in the diagram

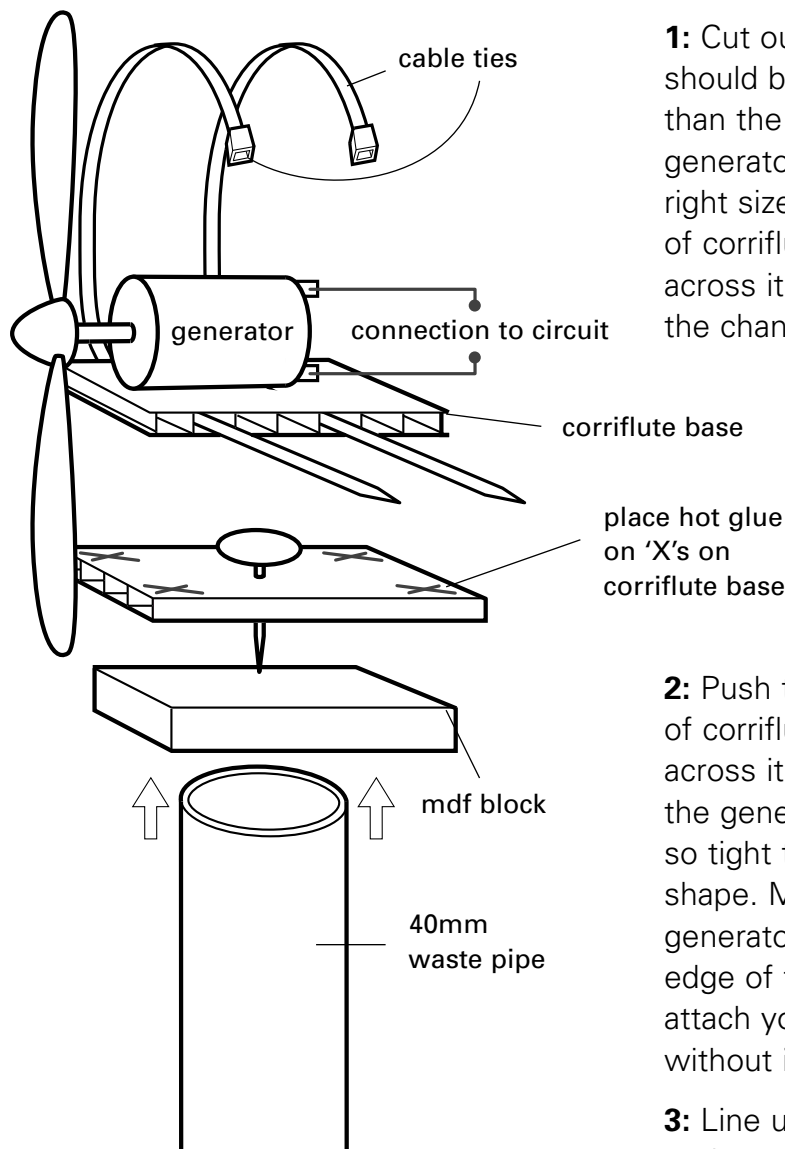

**2:** Push two cable ties through the piece of corruglute with the channels running across its width and use them to secure the generator in place. Do not pull them so tight that the corruglute bends out of shape. Make sure that the shaft of your generator sticks far enough over the edge of the corruglute so that you can attach your propeller and it will spin without interference.

**3:** Line up the second piece of corruglute underneath the piece with the generator attached. Make a mark where the middle of the generator is.



**4:** Push a small flat-head nail through the corriflute where you have made your mark.

**5:** Line up the piece of corriflute that has the nail in it with the centre of the small mdf block as in the diagram to the right.

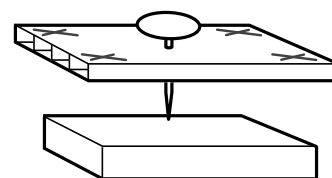

**6:** Carefully tap the nail in with a tack hammer. Make sure that the piece of corriflute is free to spin around the nail.

**7:** Place blobs of hot glue on the corners of the corriflute, taking care not to get any near the nail. Then line up the piece of corriflute holding the generator and stick the two together. Make sure that the generator can now spin easily on the nail. This will form the bearing that will allow your wind turbine to swing around to face into the wind.

**8:** Fix the generator and bearing assembly to the top of the plastic pipe with some more hot glue.

**9:** When the glue has set, fix your propeller onto the generator.

**10:** Cut out a corriflute tail plane and rudder as in the diagram below. (You could use stiff card instead of corriflute.)

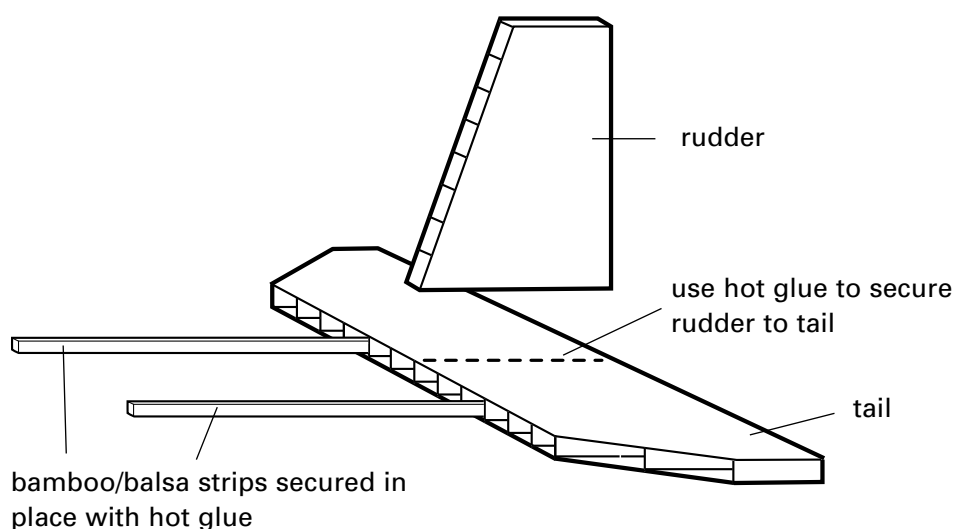

The bamboo or balsa strips need to be about 25cm long. The rudder needs to be about 12cm high and the tail plane about 12cm wide.

**11:** When the glue has set, push the bamboo/balsa strips into the channels in the bottom piece of corriflute in your bearing assembly.

**12:** You can now put your finished wind turbine on its stand and get ready to test it.



# Testing your wind turbine

## Key question

- How can we optimise the energy we get from wind turbines?

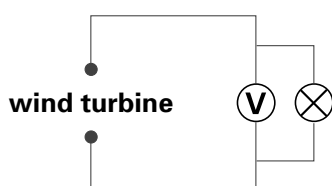

Your wind turbine can be tested either indoors using a desk fan or outdoors using the wind. In each case, you will need to build the circuit below and attach it to your wind turbine.

If your turbine is not generating enough electricity to light a small bulb, you might want to try a light-emitting diode (LED) instead.

## Testing inside

If you are testing your turbine inside, fit it on the stand provided and place it in front of a desktop fan. Make sure that your circuit is connected, then start the fan. Answer these questions either on a separate piece of paper or as part of an experiment write-up your teacher might ask you to do.

- 1: Does your light bulb or LED light up?
- 2: What is the reading on your voltmeter?
- 3: If your fan has different speed settings: in a table, record how the voltage in your circuit changes with a faster or slower wind.
- 4: Try moving the fan around in front of the turbine. Does your turbine keep facing into the wind?

## Testing outside

If you are testing your turbine outside you will need a broom handle to fit your turbine on and a small box to put the circuit in so that you can carry it easily.

- 1: Try placing your turbine in different positions around the school and record readings of the voltages it produces.
- 2: Based on the readings you have taken, where do you think the windiest place in the school is?
- 3: Do you think it would be possible to place a real wind turbine here?
- 4: What objections do you think people would have to this?
- 5: What would be the positive things about having a wind turbine to supply some of your school's electricity?



# Test your 'Cross-Wind Savonius' wind turbine and generator

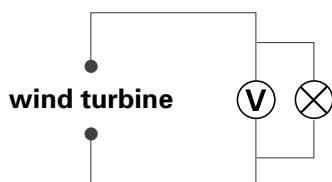

You can now test your wind turbine using a desk fan. You will need to build the circuit on the left and attach it to your wind turbine at the stator.

Remember that your generator is producing alternating current (a.c.) electricity so your voltmeter and ammeter must be set to measure a.c. voltage and current.

The objective is to calculate the power your turbine can generate. This is best done indoors with a desk fan as wind speed can then be controlled.

Arrange your turbine and generator so that it can be spun by a desk fan. Attach the above circuit and take three or four readings for a given fan speed of voltage and current. Record these readings in a table, along with the speed setting of the fan. For each fan speed, calculate the power generated by multiplying voltage (in volts) and current (in amps) to give power (in watts).

These can then be averaged to give a more accurate result.

If your fan allows, you may be able to do this for a number of different wind speeds.

Now plot a graph of electrical power against wind speed.

Answer the following questions either in your experiment write-up or on a separate sheet of paper.

- 1:** Does the power generated by your wind turbine vary with the wind speed?
- 2:** Describe how it varies.
- 3:** Try to explain why it varies. You will need to know how an electrical generator works to do this.
- 4:** How could you make this experiment more accurate?
- 5:** Can you suggest five different ways that you might be able to make your generator and turbine produce more power?



# Solar water heating

## Key question

- How can we optimise the energy we get from the sun using solar water heaters?

Solar water heating is becoming increasingly popular in the UK. The principle of using the sun's energy to heat water is very simple. It works for the same reason that the inside of a car can get extremely hot on a sunny day. Heat energy from the sun travels through the glass and heats the things inside the car, it is then re-radiated at a slightly different wavelength and cannot get back out through the glass. This heat energy is trapped, so it builds up, causing the temperature to rise much higher than the temperature outside.

We can use this idea to build a solar water heater.

Your task now is to build the most effective solar water heater you possibly can, using the materials to hand. The following instructions and diagram will help you to do this. Remember that what you are trying to do is get heat energy into your shoebox through the clear front and then to stop it from escaping.

Your teacher will have a selection of different materials you can use to build your water heater.

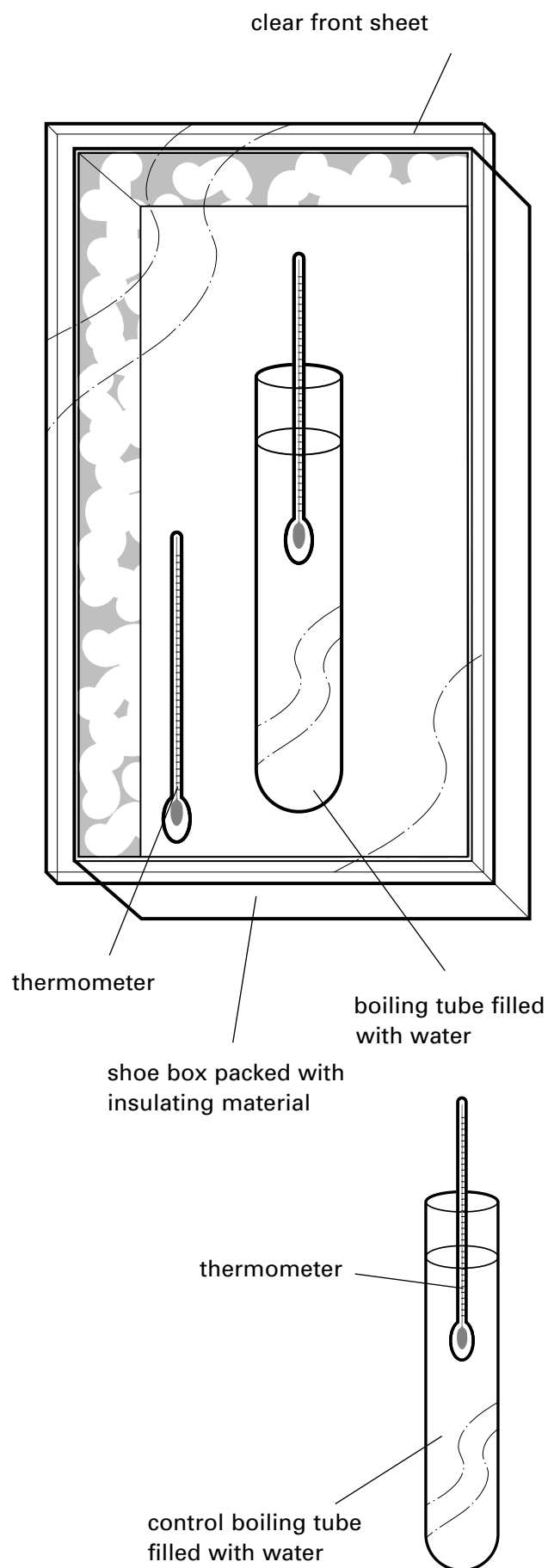



## Hints on how to set up your solar water heater

- 1:** Think about the colour of your water heater. Will changing its colour make any difference to how well it works? Are some colours better at absorbing heat energy than others?
- 2:** How could you prevent heat energy escaping from your box once it is in there? Would some form of insulation be a good idea? If so, discuss with the rest of your group what properties make a material a good insulator, and make a choice based on what you have discussed.
- 3:** Can you think of any other ways heat energy might be escaping from your box? If so, is there any way that you can prevent this?
- 4:** How might you increase the amount of energy being collected by your box?

## Testing your solar water heater

- 1:** The easiest way to test how well your water heater works is to use it to heat water. Choose two identical boiling tubes with bungs that have thermometers fitted in them.
- 2:** Fill the boiling tubes with water and put the bungs in.
- 3:** Place one boiling tube in your shoebox. The other will remain outside the box to act as a control. Make sure that you can read the thermometer in the boiling tube. You might want to fix the boiling tube in place with a piece of sticky tape.
- 4:** Place another thermometer inside the box to check the temperature under the glass. You might want to fix it in place with a piece of sticky tape.
- 5:** Once your box is complete, fix the glass or polycarbonate sheet in place with insulating tape.
- 6:** Your solar water heater is now ready for testing in the sunshine.

## Recording results

- 1:** Your box will begin to heat up as soon as the sun shines on it so you will need to start taking readings as soon as the box is in position.
- 2:** Every 30 seconds, take readings from the three thermometers and record them in a table. This information can then be plotted on a graph of temperature against time to show how effective your shoebox water heater has been.



# Renewables

## at home

### Key question

- How much of the electricity we use at home is generated from renewable energy? Could this figure be increased?

The average UK household uses about 80 to 90kWh or 'units' of electricity per week. On average, for each unit of electricity generated, about 120g of carbon<sup>1</sup> is released into the atmosphere.

In 2003, the total amount of carbon released into the atmosphere as a result of electricity production was 46 million tonnes<sup>1</sup>.

There is little doubt that the amount of carbon in the form of carbon dioxide gas being released into the atmosphere is beginning to affect the world's climate. Reducing the amount of carbon dioxide and other greenhouse gases being released into the atmosphere is likely to be one of the biggest challenges that the world faces over the next century.

Despite the scale of the problem, it is important to realise that every single person can play a part in reducing carbon emissions. This activity will help you see where you can make a difference.

#### 1: How much electricity does your family use per week?

To work this out you will need to see an electricity bill. These bills will cover a certain time period – it could be a month or a quarter (three months). They will refer to your use of electricity in 'units'. A unit is one kilowatt hour (kWh).

To calculate your weekly usage, just divide the total number of units used, as shown on the bill, by the time period the bill is for in weeks. Write your answer in the box below.

If it is not possible to see an electricity bill, use the average figures above.

Our weekly usage of electricity is  units.

**2: How much carbon has been released into the atmosphere from generating this electricity?** To calculate this, take your answer from question 1 and multiply it by 0.12. This will give you your answer in kilograms. Write your answer in the box below.

Each week our use of electricity causes the emission of  kilograms of carbon into the atmosphere.



**3: How much of our weekly electricity consumption is already generated from renewable sources?** Currently about 3 per cent of the UK's electricity comes from renewable sources. To take this into account, subtract 3 per cent from the answer you had to question 1 and fill in the boxes below.

The equivalent of  units of the electricity that we use in a week is generated from renewable sources.

This means that the equivalent of  units is generated from non-renewable sources.

**4: Your project.** Now that you know how much electricity you use in a week and how much already comes from renewable sources, it is your task to discover how you could increase this percentage.

There are two main ways that you can do this and your teacher may want you to look into both possibilities.

- Some electricity generating companies will offer to supply you with 100 per cent renewable electricity. But does this mean that the actual electricity you are using has been generated from renewable sources? Will it cost you more than 'normal' electricity? You will need to compare several different companies
- Generate your own electricity. Look at the information cards that came with this pack to see what kinds of technology might be available for generating electricity at home. You could also look at solar water heating. This does not generate electricity but it will save you from using electricity to heat your water.

It is important that your ideas are practical. If, for example, you are considering using a wind turbine, what power output will it need to have? Where could you put it? Would the neighbours object? Could you make money by selling surplus electricity back to the electricity companies? How much would your wind turbine cost?

Put all of this information into a report. At the end of the report, include a conclusion and recommendation. State clearly what you think would be the best solution and why. Estimate how much of your weekly electricity usage could be generated from renewable sources and how much carbon this would prevent from being released into the atmosphere.





# Build a 'Cross-Wind Savonius' wind turbine and generator

## Key question

- How does a wind turbine and generator work?

Wind turbines use the power of the wind to spin a generator. The generator itself relies on a conductor (usually coils of wires) cutting through a magnetic field to

induce a voltage in that conductor. This produces an electrical current.

In this activity, you will see that not all wind turbines look like giant propellers, and you will also see that building an electrical generator is quite simple.

A diagram of the finished 'Cross-Wind Savonius' wind turbine and generator is shown below in diagram 1.

**Diagram 1**

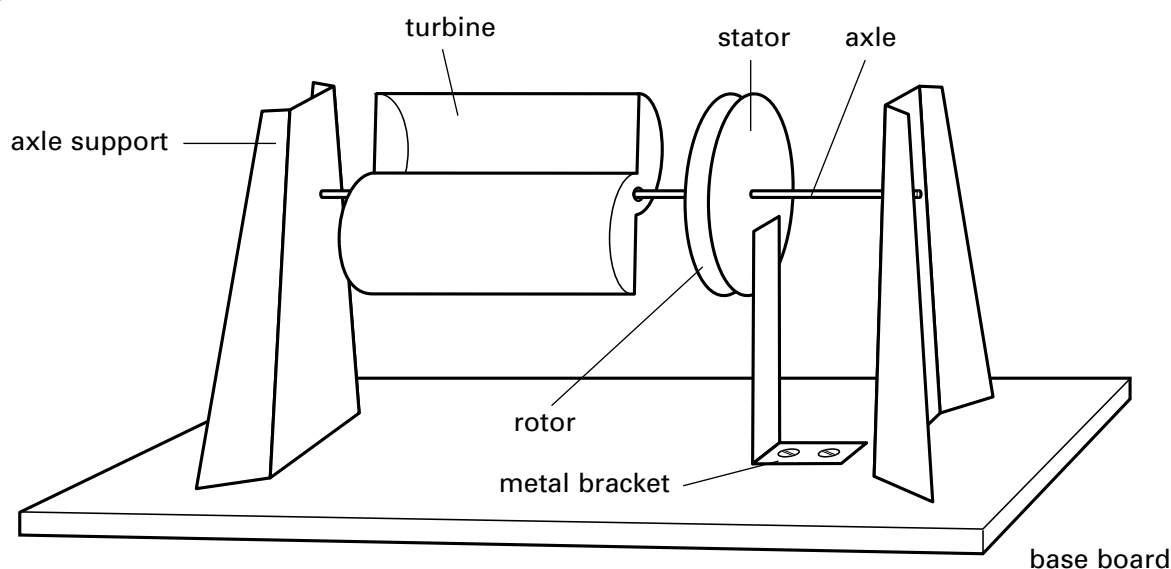

## Building your Cross-Wind Savonius' wind turbine and generator

### The turbine

- 1: Cut the top and bottom off a plastic bottle. The bottle needs to be about 1.5 to 2 litres in volume and have a circular cross section. Certain types of mineral water bottle are just right for this.
- 2: Cut the bottle in half lengthways as accurately as possible.
- 3: Stand the two halves upright on a piece of thick corrugated cardboard as shown in diagram 2.

- 4: Draw around the bottom of the bottle pieces to produce the shape shown. Mark an 'x' in the centre of the shape.

- 5: Cut out 2 copies of the shape.

**Diagram 2**

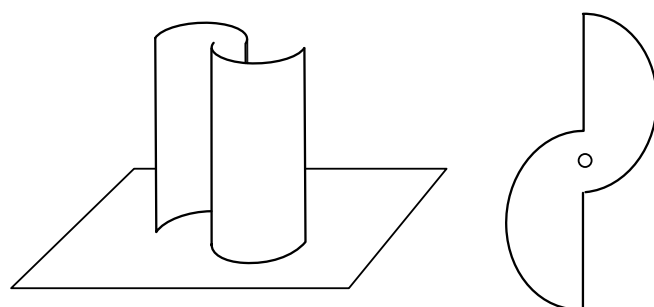



**6:** Trim the shapes so that they will fit inside the ends of the bottle pieces.

**7:** When you are sure that the pieces will fit, make a hole in each one at the position marked by the 'x'. The hole is for the axle and needs to be large enough for the dowel to fit through snugly.

**Diagram 3**

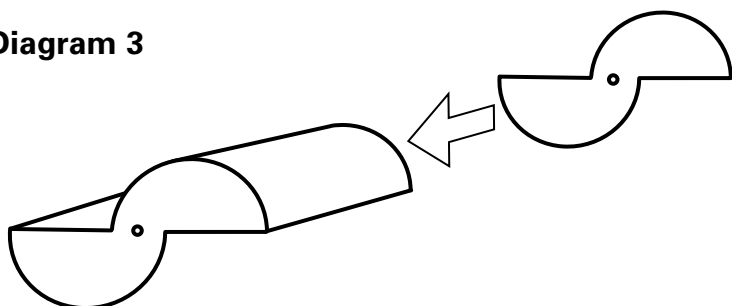

**8:** Using a hot glue gun, glue the pieces of card in position in the bottle halves as shown in diagram 3.

**9:** Once the glue has set, push the axle through the holes in the card end-pieces so that about 2 or 3cm protrude from one end, and about 10cm at the other end.

**10:** Glue the axle into position in the card end-pieces.

**11:** Your completed turbine should now look like diagram 4.

### The stator

The stator is the part of the generator that remains stationary. This is the part of the generator that holds the coils.

**1:** Use a small piece of mdf as a jig on which to wind your coils as shown in diagram 5.

**2:** Start winding with a wire lead-in of about 5cm.

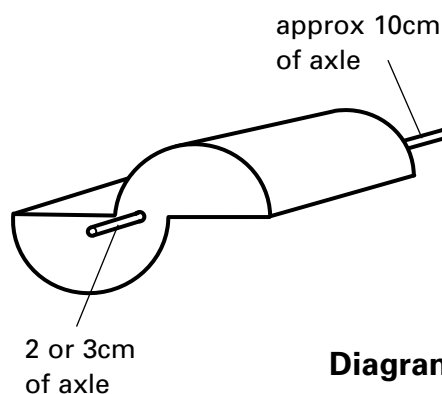

**Diagram 4**

**Diagram 5**

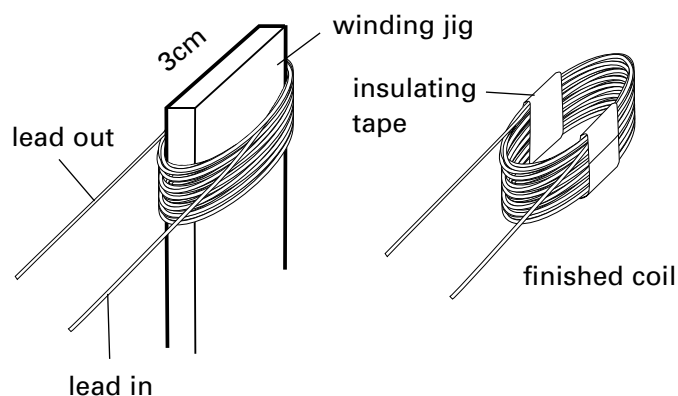

**3:** The coils must be wound as neatly as possible and each one needs to have 200 turns.

**4:** When each coil is complete, leave about 5cm of wire lead-out.

**5:** Wrap the coil with two pieces of insulating tape to keep it secure.

**6:** Now sand off the enamel from the last centimetre of each lead.



**7:** You need to wind four coils.

**8:** When the coils are wound, cut out a cardboard disc 11cm in diameter. Cut a hole in the centre about the size of a two pence coin.

**9:** Arrange the coils on the disc as shown in diagram 6. It is very important that the windings are arranged in the correct directions or your generator will not work.

**10:** When the coils are correctly positioned, fix them in place with the hot glue gun.

**11:** When the glue is set, the bare ends of the coils can be joined together with cable connector blocks, and these can be fixed to the stator plate with the hot glue gun.

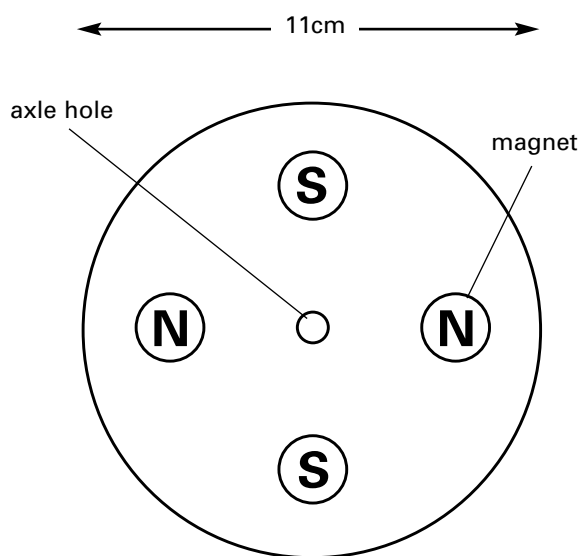

**Diagram 7**

**Diagram 6**

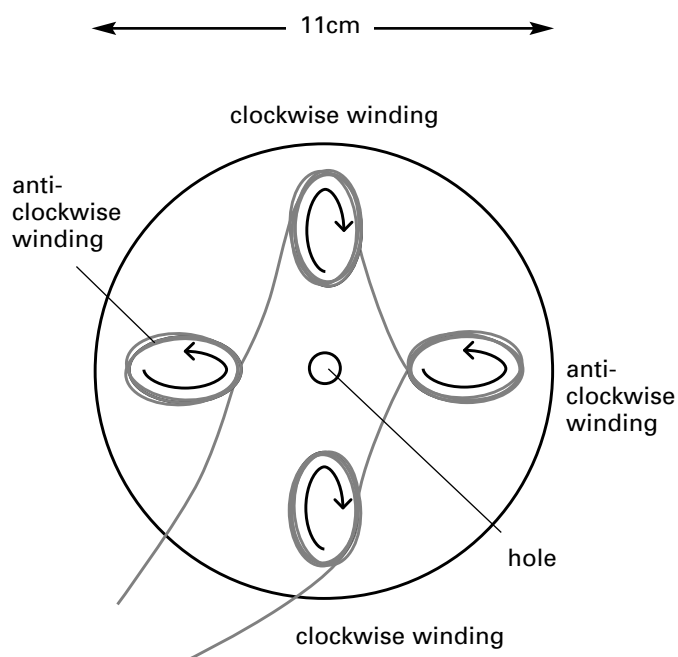

**12:** Lastly, glue the stator plate to the supporting bracket as shown in diagram 1. Once fixed, this bracket needs to support the stator so that the hole in the centre is about 20cm above the base board.

## The rotor

The rotor is the part of the generator that moves. It holds the magnets that produce the magnetic field that sweeps over the coiled conductors and induces a voltage, causing a current to flow.

**1:** Cut out another 11cm diameter cardboard disc. This time make a hole in it so that the axle will just push through.

**2:** Glue the magnets to the rotor disc as shown in diagram 7.

**3:** Make sure that the magnets are arranged with their polarities as shown in diagram 7.



## Assembling the turbine and generator

- 1:** Push the rotor disc onto the long end of the axle with the magnets facing away from the turbine assembly. Slide the disc up so that it is touching the turbine. (Diagram 1 shows a gap between the rotor and turbine, but this is so that the shape of the turbine can be seen.)
- 2:** Try to get the rotor disc as square as possible on the axle. When you are happy with its position, glue it in place with the hot glue gun.
- 3:** Lay the turbine and rotor assembly on the base board where it will eventually be installed.
- 4:** The stator needs to be fixed as closely as possible to the rotor, but they must not rub or the turbine will not be able to spin properly.
- 5:** Estimate where you will have to fix the stator support bracket to allow this. Mark this position and screw the bracket and stator in place.
- 6:** Cut out the two end supports for your turbine axle from the cardboard, as shown in diagram 8.
- 7:** Slip the turbine axle through the hole in the stator plate so that the rotor and stator are in the correct position (and not able to rub). Support the axle so that it is in the position it will need to be fixed in.

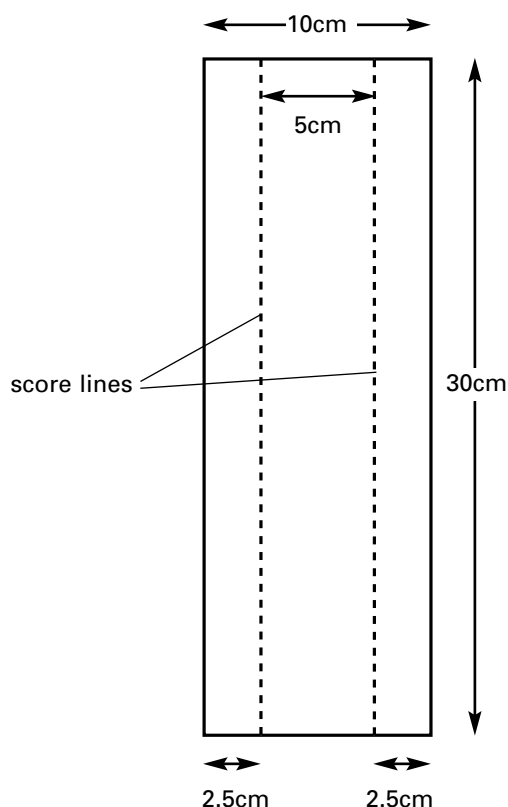

**Diagram 8**

- 8:** Stand the left-hand end support as shown in diagram 1 so that the end of the axle just touches it. Glue the end support to the base board.
  - 9:** Check that the axle is in the correct position, then push a large drawing pin through the end support into the end of the axle.
  - 10:** Install the right-hand end support and fix the other end of the axle in the same way.
  - 11:** Check that your turbine rotates freely.
- You are now ready for testing.



# Build a solar cooker

## Key question

- Is it possible to cook food without fire, gas or electricity?

Solar cookers are used in a lot of developing countries where fuel is in short supply, but where there is abundant sunshine.

Even in the UK, the amount of energy reaching each square metre of the ground can reach 4.5 to 5kWh per square metre per day in July. This is enough energy to heat the water for a large hot bath. This energy can also be captured and concentrated by a solar cooker.

There are many solar cooker designs, but this is one of the simplest and most popular. In fact, it is so simple that people sometimes forget that temperatures inside it can reach over 100°C, so make sure that you wear oven gloves when handling it. It is also a good idea to wear sun glasses as there can be a lot of glare from the reflective surfaces.

Diagram 1 on the left shows the completed cooker.

Diagram 1

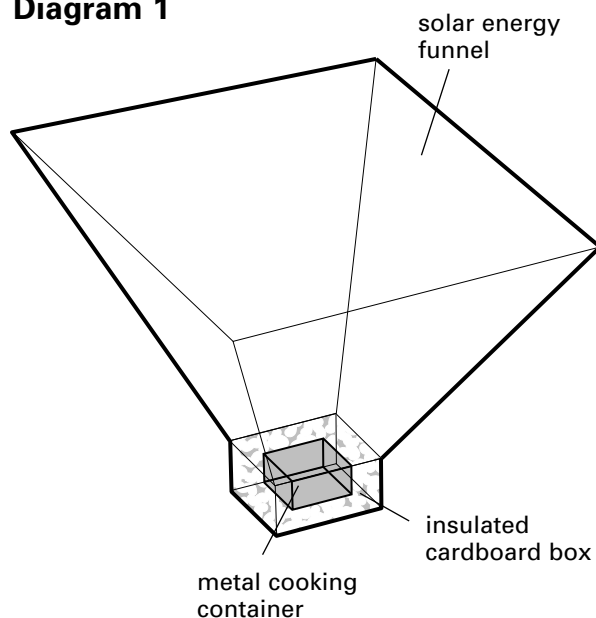

## Building your own solar cooker

**1: Before you start.** Paint the inside of your baking tin with the matt black metal paint and allow it to dry.

### 2: The solar energy funnel

- a: Using a large pair of scissors or a craft knife, cut out two sets of cardboard panels to the dimensions shown in diagram 2.

Diagram 2

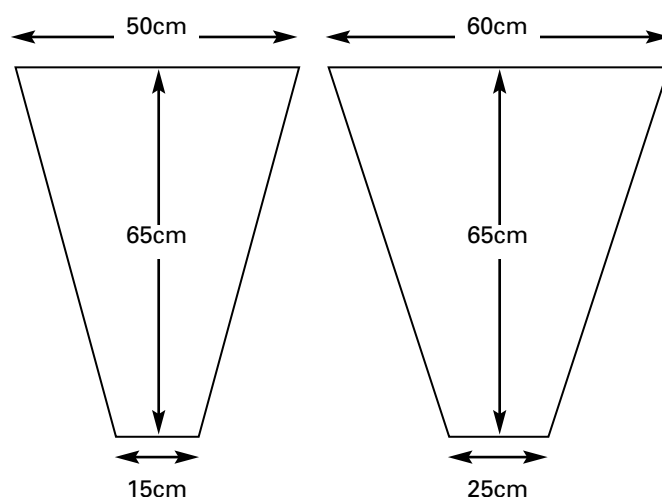



- b:** Lay out the panels as they are going to be assembled and, using a small piece of cardboard, spread a thin layer of PVA glue over the surface of one of the panels, which will form the reflective surface.
- c:** Carefully lay sheets of tin foil onto the glue and smooth them down. Try not to tear the tin foil and make sure that the shiny side is facing upwards.
- d:** Repeat for the other three panels.
- e:** When all of the panels have been coated on one side with tin foil, assemble them into a funnel shape, with the tin foil on the inside of the funnel. Join them together with duct tape to make the solar energy funnel shown in diagram 1.

### 3: The cooking box

- a:** Stand your solar energy funnel upright in a photocopier paper box.
- b:** When the box and funnel are lined up straight, duct tape the box in position. You may also want to tape up any holes in the box.
- c:** Fill the box with shredded paper or cardboard to act as insulation, but leave enough space to fit in the foil baking container.
- d:** Place the baking container in position and wedge it in place with pieces of cardboard.
- e:** When the baking container is in position, the toughened glass sheet should rest on top. Try to minimise any air gaps as the cooker will lose heat through these.

Your solar cooker is now ready for testing.

### 4: Testing your solar cooker

- a:** Your cooker will work best on a warm sunny day. To get it working, angle it towards the sun and just wait. You may have to use a few stones and whatever else is to hand to achieve the correct angle. Do not look at the sun while you are doing this.
- b:** Place an oven thermometer in the baking container and take temperature readings at regular time intervals. Be careful as you do this, because the inside of the cooker will be hot and there may be considerable glare from the reflective surfaces of the funnel. A much more comfortable way to do this is with a data logger and temperature probe.
- c:** The cooker should be taken through the cooking cycle at least two or three times before food is put in it to bake off any impurities. When food is placed in the cooker it should be held in a clean, heat-proof container and not placed directly into the painted foil baking container.

The use of oven bags is recommended.



# Build a solar water heater

## Key question

- How can we heat water for our homes without fire, gas or electricity?

This simple design uses a pressed steel radiator to act as the collector in the solar panel. This helps to reduce the construction time and costs associated with building the collector from pipe work and sheet metal.

The best type of radiator to use for the purposes of this project is the 'Stelrad'. These are particularly suitable because they have four tapped connection holes, one in each corner. This allows the necessary diagonal flow of water. This project is based around the use of a Stelrad No.44 section 1780 x 580mm radiator and all of the component dimensions are given accordingly. If a different size radiator is used, the component dimensions will have to be adjusted accordingly.

The tools and components required to complete the project are listed separately on *Activity sheet 9.2*.

Diagram 1 below shows a cross-section view of the completed heater.

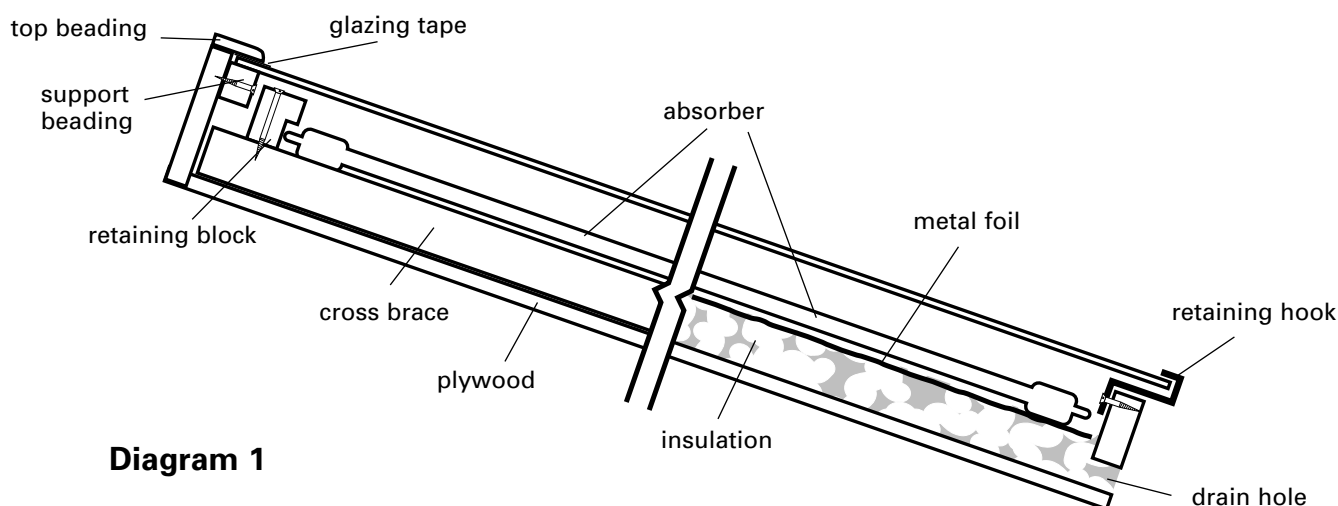

Diagram 1

## The construction process

**1:** Paint your radiator and all other pipes and connectors that will be exposed to the sunlight with matt black metal paint. This will increase the efficiency of your radiator as an absorber of solar radiation.

**2:** Cut all of the wood to the sizes given in *Activity sheet 9.2*. If the wood being used is untreated, this will be the best time to treat it for protection against weathering.



**Diagram 2** An exploded view of the solar water heater

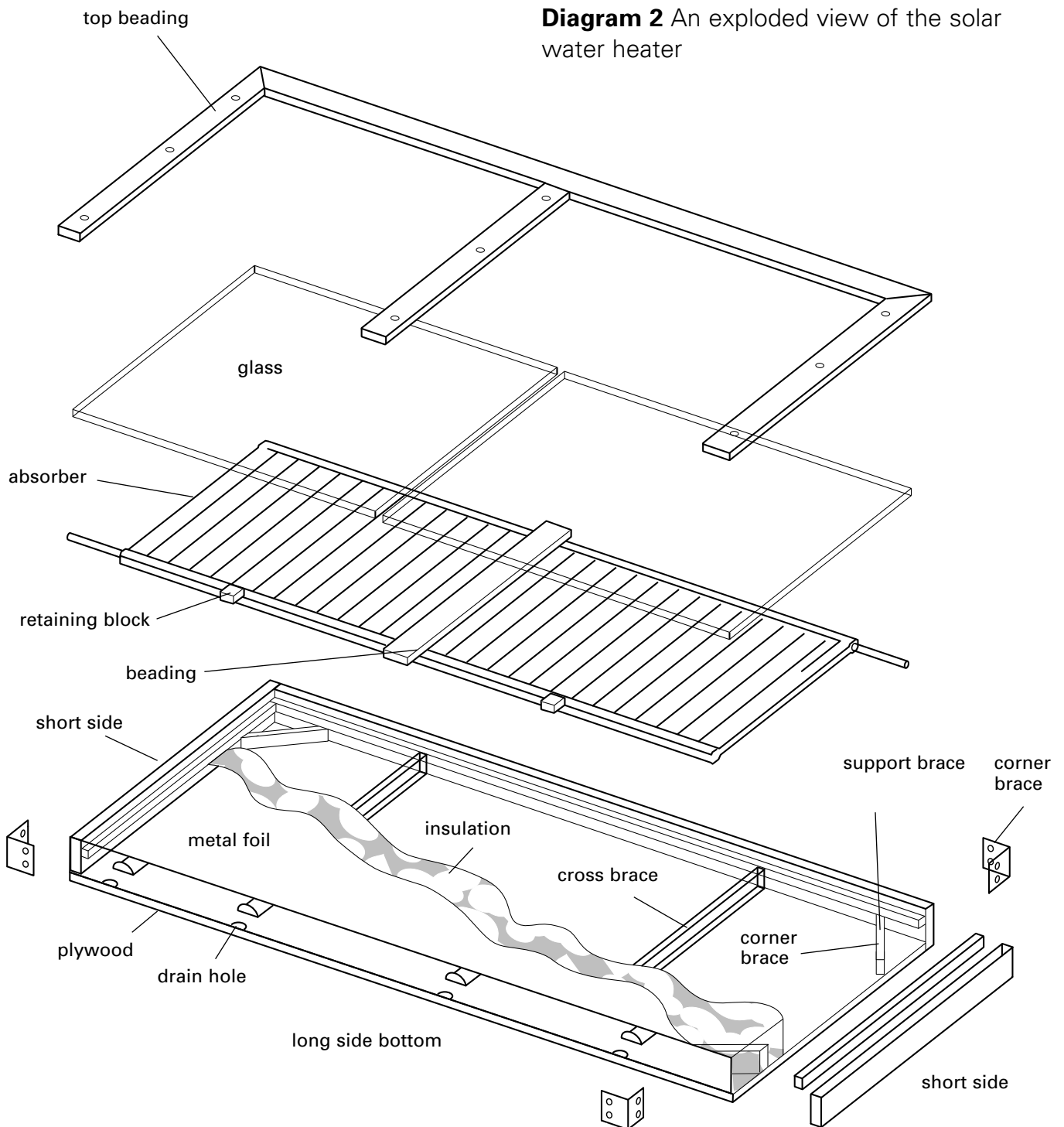

**3:** Fix the frame of the box together using screws and glue.

**4:** Fix the plywood sheet to the back of the frame with screws and glue.

**5:** Fit the four corner braces and corner brackets onto the frame and plywood backing.

**6:** Fix the two cross braces inside the box, then put Warmcel insulation between the sections.





**7:** Cover the inside of the box with metal foil, stapling it in position.

**8:** Connect a short length of 15mm copper pipe to the corners of the radiator as shown in diagram 3. The pipe needs to be long enough to protrude from the frame so that it can be joined to external pipe work.

The pipe should be fixed using the correct radiator fittings. Remember to use PTFE tape on the thread to help produce a water-tight seal.

**9:** Drill two 15mm holes in the frame to line up with the short lengths of pipe fixed to the radiator. Cut out a 'v' shape for fixing the pipes in place as shown in diagram 3.

**10:** Carefully place the radiator in position and secure it in place with the retaining blocks. It is important to make sure that there is no gap between the insulator and the radiator. Air movement between the radiator and insulator will reduce efficiency.

**11:** Fix the v-shape wedges back in place over the pipes with screws only. Do not glue them as you may need to remove them at some point in the future so you can get at the radiator to fix leaks. Seal the pipes to the box with silicon sealant.

**12:** Fit beading around the sides and top of the box to support the glazing.

**13:** Drill drainage holes in the bottom of the frame.

**14:** Paint the outside of the box with primer, then undercoat, then gloss.

**15:** When the paint is dry, fit the foam bedding strip on the beading and along the bottom edge for the glass to rest on.

**16:** Fit the glass retaining hooks at the bottom of the box.

**17:** Carefully position your glazing and secure it with silicon mastic, acrylic putty or glazing tape. Linseed oil putty is not recommended as it does not weather well.

**18:** Screw the glass retaining cover strips in place.

**19:** Your solar heater is now complete. It can be fitted to a domestic hot water system and details on how to do this are available from The Centre for Alternative Technology ([www.cat.org.uk](http://www.cat.org.uk)). For demonstration purposes, it can be connected to a circulation pump and home-made heat exchanger.

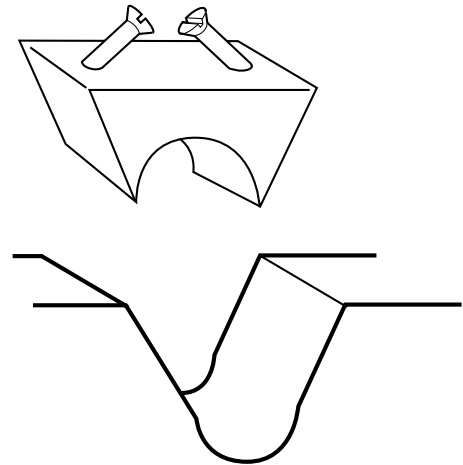

**Diagram 3**



# Tools and materials needed to build a solar water heater

## Tools

Hammer  
Saw  
Tape measure  
Screwdriver  
Electric drill and a variety of drill bits  
Stanley knife  
Bradawl  
Plane  
Chisels  
Adjustable spanner  
Mastic gun  
Putty knife

## Materials

**Softwood** Planed all round, treated against rot. The dimensions given below are finished sizes in mm. For example, 95 x 20 is the planed size of 100 x 25.

Part	Size (mm)	Length (mm)	Amount
Long side, top	95 x 20	1875	1
Long side, bottom	89 x 20	1835	1
End sides	95 x 20	670	2
Beading, top side	20 x 10	1835	1
Beading, ends	20 x 10	640	2
Cross brace	45 x 20	650	2
Corner braces	20 x 50	350	4
Central beading	45 x 20	650	1
Top beading, long side	40 x 8	1875	1 mitre end
Top beading, end sides	40 x 8	702	2 mitre ends
Top beading	40 x 8	665	1
Retaining blocks	45 x 20	60	4

**Plywood** Exterior quality 9mm, 1875 x 690mm

**Glazing** This can be glass, 'Filon' or polycarbonate. Two 3mm thick sheets are needed. The dimensions will be 900 x 680mm, but it is recommended that this is measured from the completed box.



**Absorber** 'Stelrad' No.44 section 1780 x 580mm radiator available from most builders' or plumbers' merchants.

**Glass retaining hooks**

**4 x flattened 15mm copper pipe**

**Corner brackets**

**Sheet metal** 60 x 60mm right angle, 95mm deep

**Insulation** 50mm thick Warmcel. This material is a cellulose fibre insulation made from recycled newspaper. It is available from Excel Industries, 13 Rassau Industrial Estate, Ebbw Vale, Gwent NP3 5SD  
Tel: 01685 845200

Alternatively, glass fibre loft insulation can be used but remember to take the necessary safety precautions when handling it.

**A sheet of aluminised building paper**

approx 2 x 0.75m

**Miscellaneous**

Matt black metal paint

Wood primer

Undercoat and gloss

Foam bedding strip

Silicon mastic, acrylic putty or glazing tape

Two screw thread fittings for connecting 15mm copper pipe to the radiators

A selection of screws

PVA wood glue



# Renewables

## at school

### Key question

- How much of our school's electricity is generated from renewable energy? How could we increase this figure?

### Introduction

As you are no doubt already aware, the use of fossil fuels is crucial to the way we live today. We use them for generating electricity, for powering our vehicles, making plastics and many other applications. However, it is clear that fossil fuels are not going to last forever. Some forecasts expect the world's oil fields to start running dry in the next 40 years. Fossil fuels also pollute. Every time fossil fuels are burnt, they release carbon dioxide gas into the atmosphere. This gas is believed to be a major cause of the climate change scientists are observing around the world.

It is clear that we have to reduce our use of fossil fuels and find alternative sources of energy.

This project is designed to help you explore the different options available for generating energy from renewable sources. It is also designed to show you that all methods of generating energy have positive and negative aspects associated with them. These may be environmental, such as pollution from fossil fuels and flooding of valleys for hydroelectric projects. They can also be social, for example, not everyone would be happy living next to a wind turbine.

### Your project

Your project is to examine the energy consumption of your school and make recommendations as to how these energy needs can be met in part or in full using renewable energy sources. The project can be divided into three phases – collecting data and information, examining the options and making recommendations. The instructions below will guide you through these phases.

If you are working in a group, make sure each member of the group has a set task to carry out. One member of the group should take on the role of Project Manager. This person will need to oversee the development of the project and ensure that all tasks are completed correctly and to schedule.

### Phase 1 – Collecting data and information

**1:** Firstly, you will need to find out which energy sources your school already uses. These might include electricity, gas, oil or your school may already use some renewable sources.

**2:** You will then need to find out how much energy is used and how it is used, e.g. heating, lighting, power etc. Your teacher may be able to provide you with a sheet with some or all of this information already on it.



**3:** You will need to collect information about what resources might be available for use with renewable energy technology. For example, your school may have a large, windy playing field, it may be close to a fast running stream, it may be in a rural area where straw and animal waste is abundant.

**4:** You will also need to collect information about what technology is available for generating electricity from renewable sources. It is important that you keep this part of the project realistic. There are a huge number of companies with websites advertising the kind of technology that you might use.

## Phase 2 – Examining the options

**1:** When you have collected all of the information and data you need, you must examine the options. Would a wind turbine be practical? How much energy would it generate? How big would it be? Would it distract students in the classrooms? These are the kinds of questions you would need to ask. To answer some of them, you may need to conduct some surveys with students and staff. Think of some more questions and design a table to help you keep track of all the factors you would need to consider for each option.

**2:** You may also want to use some ICT skills to show what a wind turbine might look like on your playing field, or what the school roofs might look like covered in solar panels.

**3:** You will also need to consider the costs and whether there might be any grants available for the options you are considering.

## Phase 3 – Making recommendations

Based on what you have found out in Phase 1 and Phase 2, you need to make a set of recommendations. These recommendations will need to be justified. If you recommend installing a hydrogen fuel cell, explain why. Back up your recommendation with details of possible power output, cost to install, cost to run, etc, and feedback from your surveys.

Your report should be as professional as possible. Hopefully it will show you the potential of renewable energy and maybe some of your recommendations will be implemented.