

Water for the World

**Constructing Intakes for Ponds,
Lakes and Reservoirs**
Technical Note No. RWS. 1.C.2

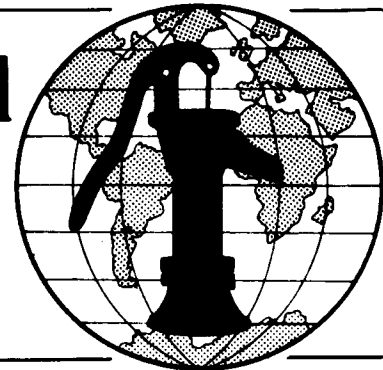

The installation of intakes makes water more easily available for community water supplies. Not only does water become more accessible, but chances for human contamination of the water are reduced. Water is pumped through the intake into storage and is made available to the community from community standpipes or house connections.

This technical note describes the construction of three types of intakes for ponds, lakes and reservoirs, and outlines the construction steps that must be followed. For information on small earth dams and reservoirs see "Designing Small Dams," RWS.1.D.5.

Materials Needed

Before construction begins, the project designer should give you the following items:

1. A map of the body of water marked with the location of the intake, distances and construction areas as shown in Figure 1.

2. A list of all labor and materials needed for the project similar to the sample list in Tables 1, 2, or 3.

3. A detailed plan of the intake structure with all dimensions.

Construction Steps for a Floating Intake

1. Stake out the construction sites with rope and pointed sticks or wooden stakes. The areas which should be marked are the trench line for the pipe, the pump location, and the site for the storage well if there is to be one. The pipeline trench should be about 0.5m wide and should follow a direct line from the intake to the pump.

Useful Definitions

ANTI-SEEPAGE COLLAR - A circular device made from concrete or metal, welded or bonded to pipe, that prevents water from flowing along a pipe installed in a dam embankment.

CLEAR WATER WELL - A sedimentation area or sump into which an inlet discharges water and from which water is pumped to distribution for community use.

GALVANIZED IRON PIPE - Zinc-coated iron pipe similar in size to rigid plastic, but heavier.

GLOBE OR GATE VALVE - Types of cutoff devices used in pipelines to control the flow of water in a system. The globe valve causes a high resistance to water flow because of small passageways. The gate valve when fully open allows straight-line water flow with very low resistance.

INLET STRAINER - Material, usually wire screen, that is put over an inlet pipe to remove sediment and plants from the flowing water.

POLYETHYLENE PIPE - Black, lightweight, flexible pipe used in water systems.

POLYVINYL CHLORIDE PIPE (PVC) - A white, rigid, plastic pipe used in water systems.

2. Prepare the intake pipe. Drill 8-10mm inlet holes or cut slots in the pipe and wrap the perforated section in 10mm wire mesh as shown in Figure 2. These holes should be about 25mm apart and cover a length on the end of the pipe of between 0.2m and 0.5m. Do not wind the mesh too tightly. Attach it to the pipe with a clamp. Be sure to plug the end of the pipe so that water only enters by the inlet holes through the mesh.

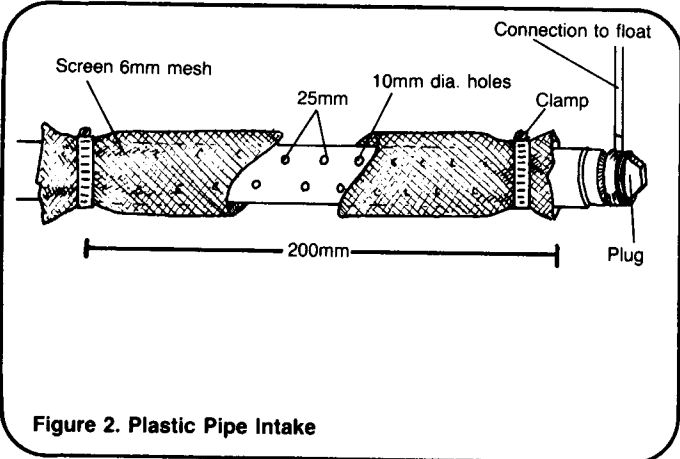
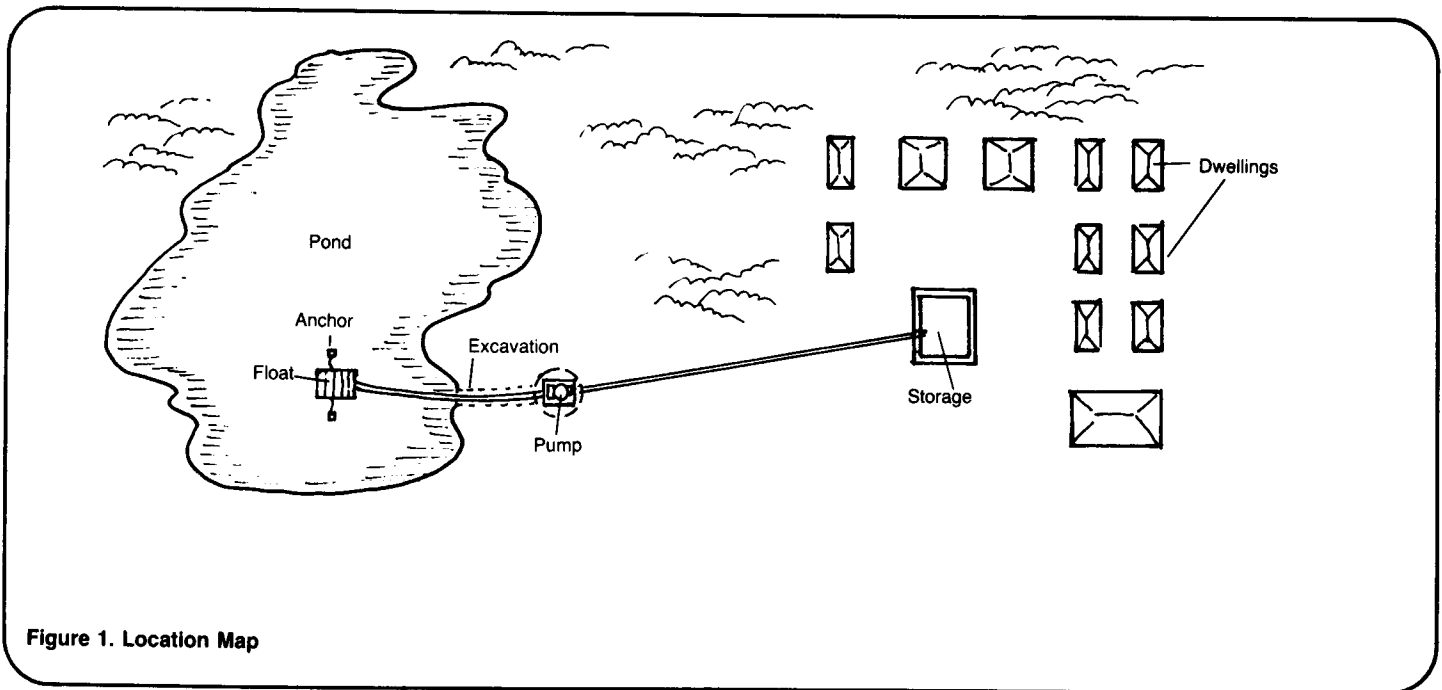

3. Attach three lines to the float, connect two of them to anchors and one 0.3-0.5m long to the floating intake. If concrete anchors are used, be sure to plan for the seven days that the concrete must cure.

4. Load the pipe, anchors and float into a boat. If the pond is shallow, take the materials out by wading to the deepest point.

5. Lower the anchors into the water. They should be centered on the location marker and separated by twice the distance of the expected high water level. See Figure 3.

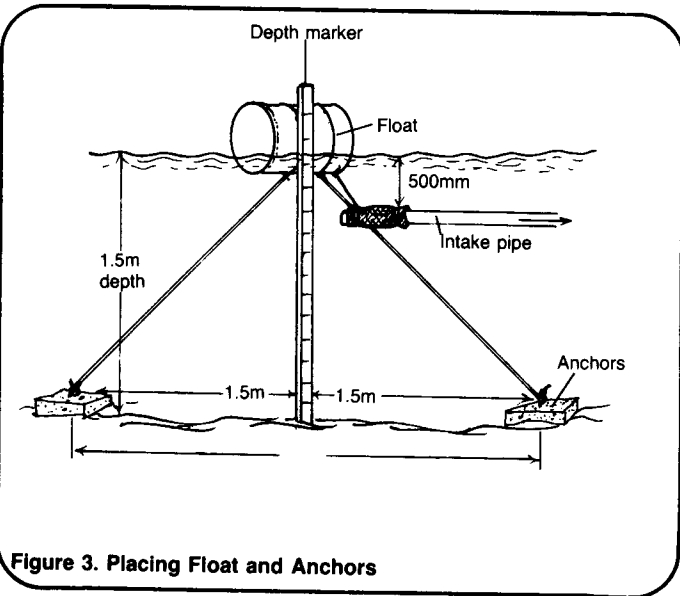

6. Begin digging the trench for the pipeline. The trench should be at least 0.5m deep. Dig only about a 1m length, starting inland and moving toward the shoreline. This method should reduce the amount of water entering the trench. If water does get into the trench, remove it with a bucket. See Figure 4.

7. With one person holding the intake pipe, begin stretching out the rest of the pipe and pulling it toward shore. At the shore, place the pipe in the trench and begin backfilling. Backfill to about 0.5-0.6m from the shoreline or to the point at which less water is entering the trench. Then

extend the trench to where it will meet the connection to the pump. The trench should be dug in a direct line to meet the pump most easily. Leave the last 0.6m of the trench open to have room to work with the pipe. When flexible pipe is used, the pipe may have to be anchored so that it does not bend. Flexible pipe floats and should be weighted down. See Figure 5.

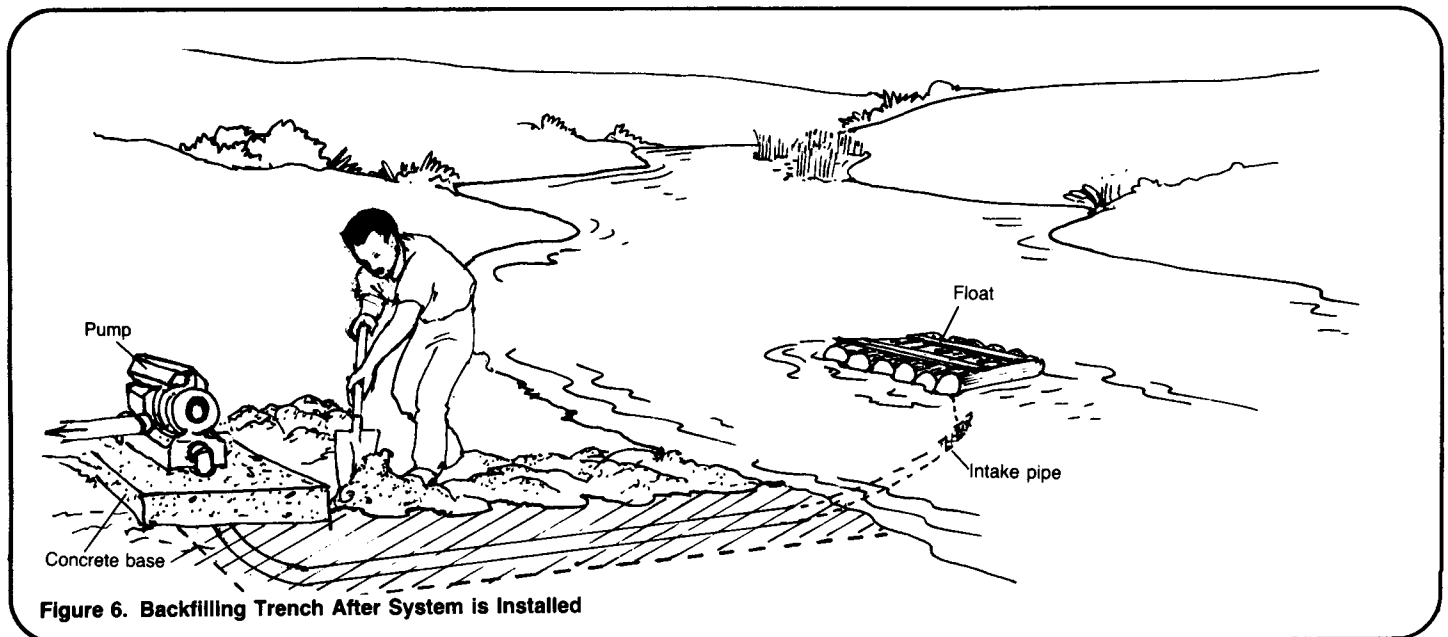
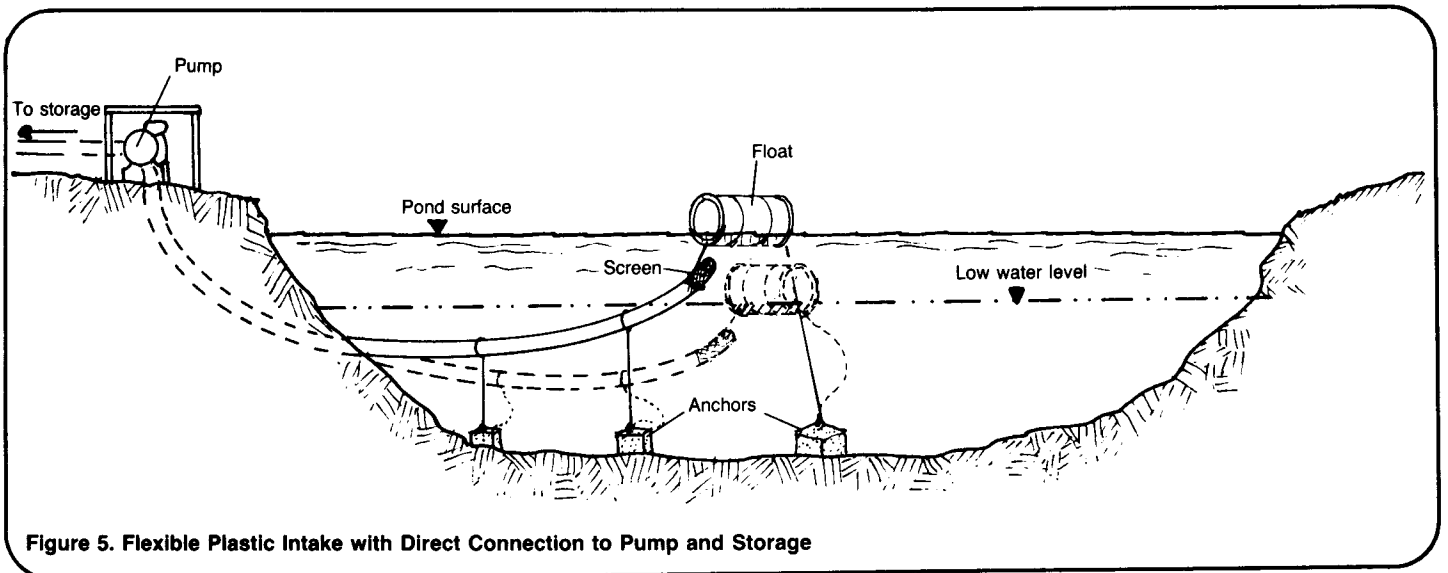
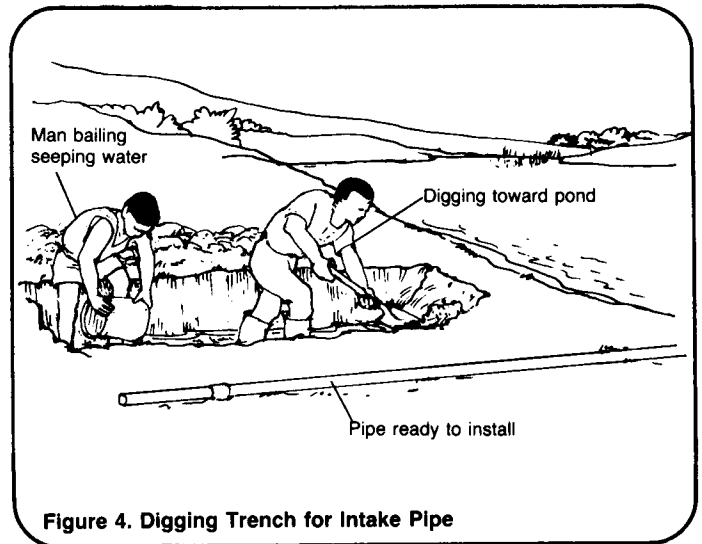

8. Install the pump. For information on pump installations, see "Installing Mechanical Pumps," RWS.4.C.2, or "Installing Hand Pumps," RWS.4.C.3. Use "Constructing Dug Wells," RWS.2.C.1, in constructing a storage well. Figure 6 shows the connection of an intake pipe to a pump.

Construction Steps for an Intake on Fixed Supports

1. When staking out the area, connect a line from the clear water well or pump to the intake site. The string marks the path that the pipe and pipe supports must follow.

2. Prepare the intake pipe. Drill 8-10mm holes or cut slots in the plastic pipe and cover the perforated sections with 10mm wire mesh. The holes should be 25mm apart. Clamp the mesh into place.

3. Assemble the supports. If concrete supports are used, build the forms, oil them and pour a concrete mixture of one part cement, two parts sand, and three or four parts gravel into them. See "Constructing Structures for Springs," RWS.1.C.1 for details on using concrete. Allow seven days for curing before removing the forms. If wooden supports are used, installation can begin immediately.

4. Connect the intake pipe with other pipe lengths so that there is a length of pipe that reaches from the intake point to the shore.

5. Place the supports on the pond or lake bed along the line of the string. Leave at least 1.5m between each support. A general rule to follow is to use two supports for each length of pipe in order to provide sufficient support. Fix the supports in place by driving them into the bottom with a sledge hammer or by anchoring them with large rocks. If the clear water well is fed by gravity flow, the installed pipe should slope at a one percent grade toward the well. See Figure 7.

6. Dig a trench at least 2m long and 0.5m deep. Begin digging from the shore toward the water to prevent water from entering the trench. If the water will flow into a clear water well, be sure the trench slopes toward it at a one percent grade.

7. Place the pipe on the supports. To do this, fill the pipe with water so that it sinks. When lowering the pipe, position a person at each support to guide the pipe onto the supports and fix it there while backfilling begins on the shore.

8. Fit the pipe into the trench and backfill to within 0.6m of the end. Insert a new section of pipe into the trench and couple it with the pipe already there. Be sure no water is in the trench when the coupling is done. Lay enough pipe to reach the pump or storage well and backfill to within 0.6m of the end of the pipe.

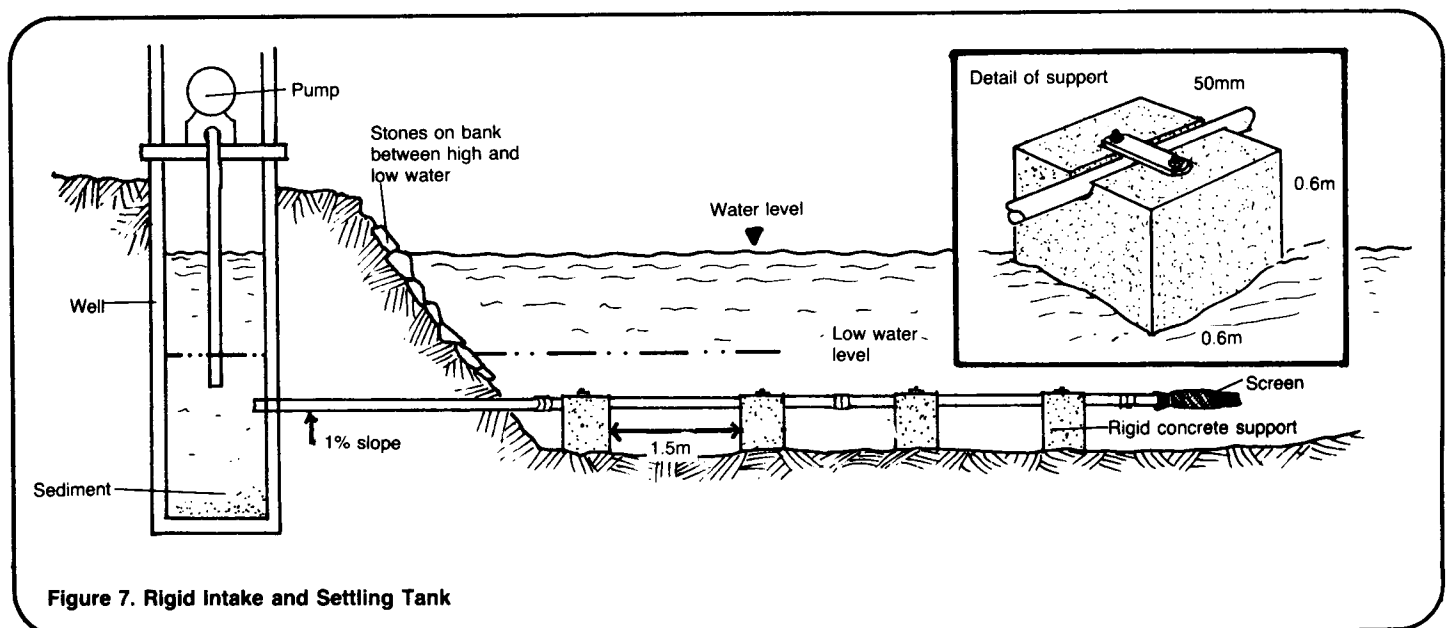

Figure 7. Rigid Intake and Settling Tank

9. Install the pump or dig the clear water well using the technical notes referred to in Step 8 of the section on floating intakes.

Follow the same steps mentioned above for installing an intake as shown in Figure 8. In addition follow these steps:

1. Build the forms for a cement base. A square base 0.6m x 0.6m should be large and heavy enough. The height should be sufficient so that the pipe used for the intake is contained in the block. A space should be made in the forms so that the pipe can be put in place before the concrete is poured.

2. Place the pipe in the forms and brace the forms before pouring the concrete. After pouring, allow the cement to cure for seven days.

3. After the concrete is cured, installation should be easy. An elbow joint and a screened vertical intake pipe should be connected to one end. The other end of the pipe is connected to the pipeline leading to the pump.

4. To install the intake, lower it into the water with rope. Attach floats to the rope to mark the location of the intake so it can be found easily when maintenance is necessary.

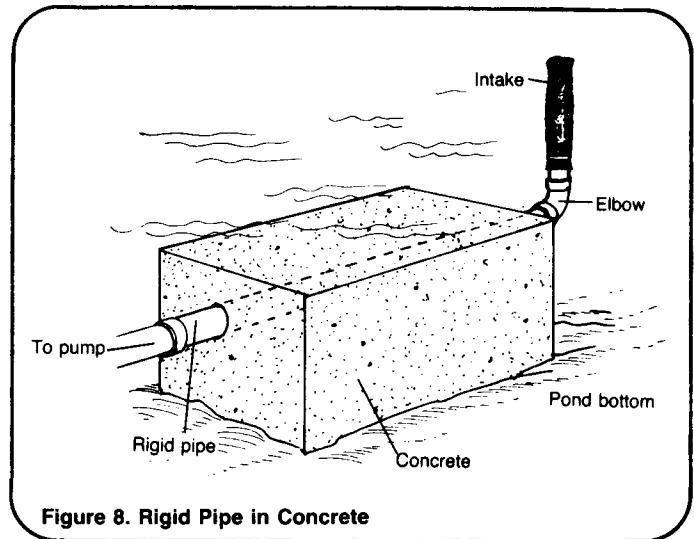

Figure 8. Rigid Pipe in Concrete

Construction Steps for a Concrete Box Intake for Dam Reservoirs

This intake system can only be constructed at newly proposed dam sites. It cannot be installed in existing dam reservoirs.

1. Stake out the proposed site for the dam and the location of the concrete box within the reservoir. Mark out the proposed walls and determine the approximate location of the intake. It should be near the foot of the upstream wall at a deep spot behind the dam. Use the information on dam design in "Designing Small Dams and Water Impoundments," RWS.1.D.5, to stake out the area. See Figure 9.

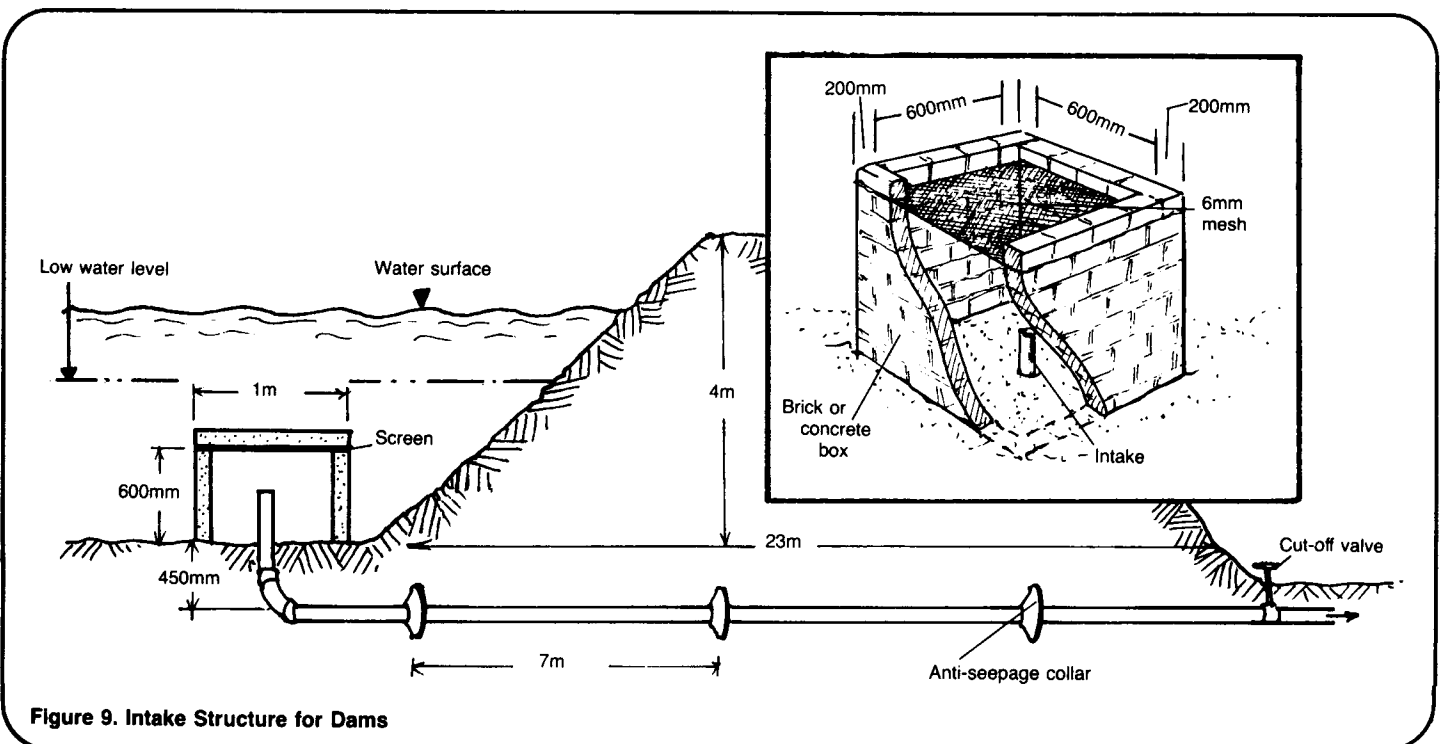

Figure 9. Intake Structure for Dams

2. Stake out the pipeline trench by measuring the distance from the intake box to a point 2m beyond the downstream wall of the proposed dam. The pipe should be 45cm below the base of the dam embankment.

3. Dig a trench about 0.45m deep for the pipe. Either plastic or galvanized pipe can be used. Lay and couple the pipe in the excavated trench from the intake point to 2m beyond the downstream side.

4. Place anti-seepage collars on the pipe running below the dam embankment as shown in Figure 10. Anti-seepage collars will prevent erosion of the dam embankment. Water may flow from the reservoir along the pipe and the compacted earth and erode the embankment. Anti-seepage collars slow down the flow and spread the water out over a larger area which prevents erosion. The collars can be made of concrete or sheet metal. They should be 0.4m in diameter (0.2m from the pipe to the outside edge) and between 50mm and 25mm thick.

Place the anti-seepage collars about 7m apart along the section of the pipeline under the dam embankment. If galvanized pipe is used, corrugated sheet metal collars can be welded to the pipe if welding equipment is available. If not, it is best to build forms to cast concrete rings. Be sure that a good bond is formed with the pipe when using concrete rings. Read "Installing Pipes," RWS.4.C.1, for installation information.

5. Attach an elbow joint at the end of the pipe where the intake will be located and a globe valve at the outflow end to control flow.

Dig out an area 1m x 1m square and 0.1m deep on the floor of the reservoir where the intake will be located. This will serve as the base for the protective box. Place the base so the intake is located exactly in the middle.

6. Build the protective box around the intake. Make the forms for the box 1m long, 1m wide, and 60cm high. The wall should be 10cm thick. Leave a hole for the intake pipe above the pipe elbow in the floor of the forms. See Figure 9.

7. Mix concrete in the ratio of one part cement, two parts sand and three parts gravel and pour it into the form. Allow seven days for curing. See "Constructing Structures for Springs," RWS.1.C.1, for details on working with concrete.

8. Remove the forms and put a small vertical extension of pipe in the elbow joint so that it is about 0.3m or 0.4m above the floor. Seal the area around the pipe and floor with mortar.

9. Place 10mm wire mesh screen over the box and weight it down in concrete blocks.

(NOTE: Concrete blocks and mortar can be used to build the protective structure. A concrete ring can also be used.)

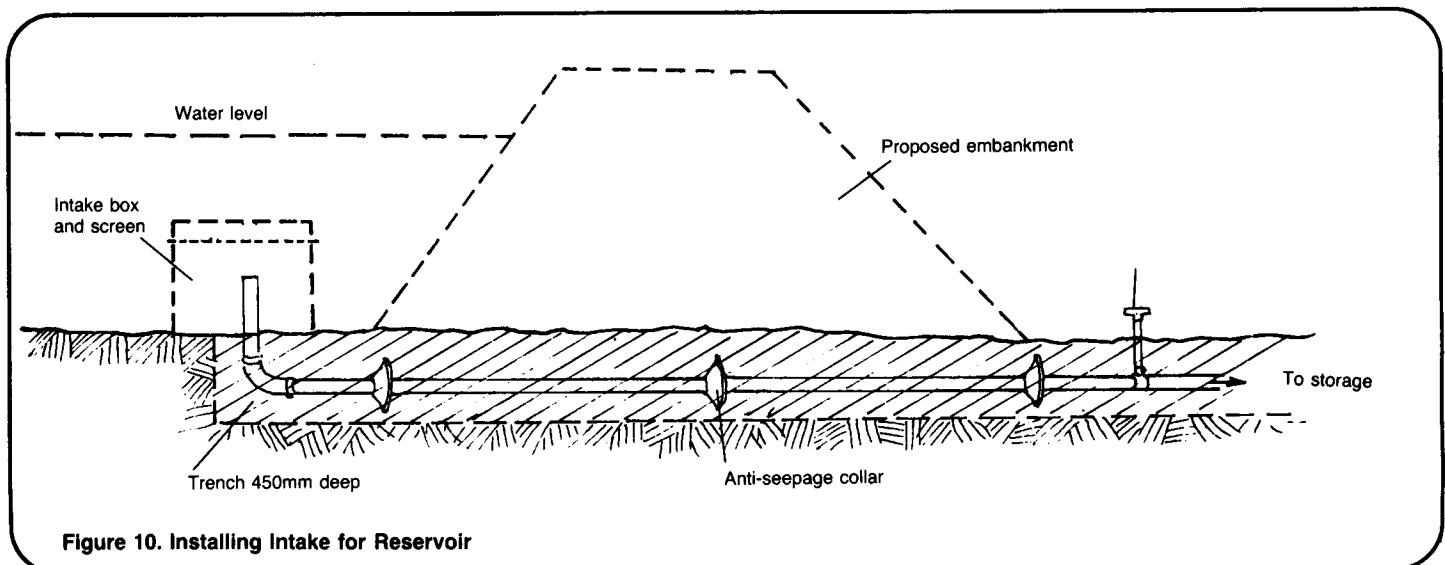

Figure 10. Installing Intake for Reservoir

Table 1. Sample Materials List for Floating Intakes

Item	Description	Quantity	Estimated Cost
Labor	Foreman Laborers	_____ _____	_____ _____
Supplies	Flexible plastic pipe 10mm wire mesh screen (for strainer) Plug (for end of pipe) Floats (wood, bamboo, barrels or plastic containers) Anchors (rocks or cement) Rope Tie wire Wooden stakes Knotted rope with weight Clamps	_____ _____ _____ _____ _____ _____ _____ _____ _____ _____	_____ _____ _____ _____ _____ _____ _____ _____ _____ _____
Tools	Digging tools Small drill Nails Hammer Bucket Measuring tape Small boat or raft Saw Knife	_____ _____ _____ _____ _____ _____ _____ _____ _____	_____ _____ _____ _____ _____ _____ _____ _____ _____

Total Estimated Cost = _____

Table 2. Sample Materials List for Rigid Plastic Intakes

Item	Description	Quantity	Estimated Cost
Labor	Foreman Laborers	_____ _____	_____ _____
Supplies	PVC pipe Couplings and pipe glue 10mm wire mesh screen Plug (for end of pipe) Clamps Wood for pipe supports (or cement, sand, gravel, for concrete and wood for forms) Globe valves String Wooden stakes	_____ _____ _____ _____ _____ _____ _____ _____ _____ _____	_____ _____ _____ _____ _____ _____ _____ _____ _____ _____
Tools	Digging tools Hack saw Wood saw Sledge hammer Nails Bucket Measuring tape Small drill	_____ _____ _____ _____ _____ _____ _____ _____	_____ _____ _____ _____ _____ _____ _____ _____

Total Estimated Cost = _____

Table 3. Sample Materials List for Concrete Box Intakes

Item	Description	Quantity	Estimated Cost
Labor	Foreman	_____	_____
	Laborers	_____	_____
Supplies	PVC or galvanized pipe	_____	_____
	Elbow joint	_____	_____
	Cement	_____	_____
	Sand	_____	_____
	Gravel	_____	_____
	Wire mesh screen	_____	_____
	Concrete blocks	_____	_____
	Globe valve	_____	_____
	Wood for forms	_____	_____
	Anti-seepage collars	_____	_____
	Pipe glue	_____	_____
	Couplings	_____	_____
String	_____	_____	
Wooden stakes	_____	_____	
Tools	Digging tools	_____	_____
	Mortar box	_____	_____
	Hammer	_____	_____
	Nails	_____	_____
	Bucket	_____	_____
	Hack saw	_____	_____
	Measuring tape	_____	_____

Total Estimated Cost = _____

Technical Notes are part of a set of "Water for the World" materials produced under contract to the U.S. Agency for International Development by National Demonstration Water Project, Institute for Rural Water, and National Environmental Health Association. Artwork was done by Redwing Art Service. Technical Notes are intended to provide assistance to a broad range of people with field responsibility for village water supply and sanitation projects in the developing nations. For more detail on the purpose, organization and suggestions for use of Technical Notes, see the introductory Note in the series, titled "Using 'Water for the World' Technical Notes." Other parts of the "Water for the World" series include a comprehensive Program Manual and several Policy Perspectives. Further information on these materials may be obtained from the Development Information Center, Agency for International Development, Washington, D.C., 20523, U.S.A.