

How to Make Your Own Detector

YOU CAN build a quality metal detector on your own home workbench. It's fun and depending upon your junk box and parts hunting ability, you can save as much as a hundred dollars over the cost of an equivalent commercial instrument.

The workbench referred to can be a kitchen table, a plank set up in the recreation room or a tool scarred bench in a basement shop. The only firm requirement is that you follow the assembly plans and instructions to the letter. Not only will this approach result in a quality instrument that won't let you down, but it will provide a basis for comparing commercial detectors and the claims made for them.

The electronic instrument described in the following pages is a *beat frequency* metal detector. It requires **only commonly available standard electronic components**. Avoid the use of components with values other than specified. Performance and stability may be seriously affected if these instructions are not followed.

The total cost of this instrument should not exceed \$50.00 assuming that the parts are purchased off the supplier's shelf. Parts obtained from surplus or a junk **box can be used** to keep the cost **down**.

Construction Methods

The plans for this semi-miniaturized electronic device offer the builder a choice between two construction methods: hand wiring or an etched circuit board; more commonly known as printed circuitry.

An experienced worker may prefer to use the schematic diagram below to make electrical connections with **point-to-point wiring**. This is a convenient way to make use of material on hand such as perf board and physically large components.

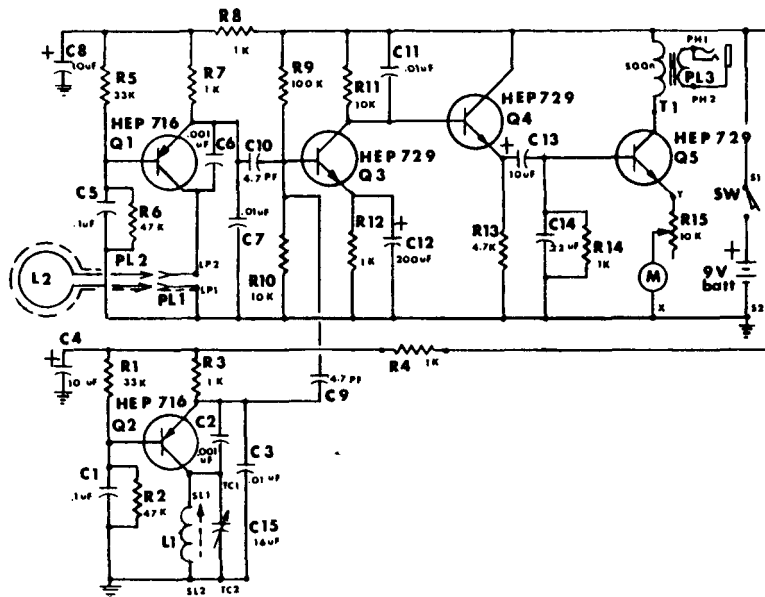

Schematic diagram of beat frequency 5-transistor metal locator described in the text.

The etched circuit board (PC board) approach is the method with the least pitfalls and is therefore the best choice for beginners. Not only will the PC board insure rock-steady stability, but the predetermined accuracy of this type construction minimizes the chance for error.

The schematic diagram furnishes information essential to the builder employing the etched circuit board method as well as the hand-wiring buff and experimenter. Consult this diagram to determine the cause of a malfunction such as may occur in any electronic device when component parts become defective through use or mishap. It is necessary to refer to the schematic because the electrical design of the instrument cannot easily be read from the physical layout of the PC board, **shown** in Figure 2 later in this chapter.

Tools

You will need a few hand tools to build the detector. The average home or car owner's tool kit includes most of these implements. They are as follows:

1. 6-inch, long-nosed pliers (needle-nosed)
2. 6-inch diagonal cutting pliers
3. Screwdriver assortment
4. **25-30-watt** pencil-type soldering iron
5. Standard metal-cutting twist drill set ($1/16''$ to $1/2''$ diameter)
6. #60 high-speed steel metal-cutting twist drill
7. $1/4$ -inch electric or hand speed drill and chuck
8. Hacksaw with fine-tooth blade
9. Bench vise

Supplies

The tool kit must be supplemented with the following

nonelectronic supplies, obtainable from electronic supply dealers and department stores:

1. Plain 00 steel wool
2. Solder (refer to text)
3. Copper circuit board etchant (1 pint)
4. Circuit board "resist" enamel (choose from brush-on, ballpoint dispenser or felt pen)
5. Copper-clad (one side only) epoxy glass laminate for printed circuit use (substitute bakelite copper laminate if epoxy glass is not available), finished size 2½" x 4½"
6. Plastic tray, 4" x 5" x 1" deep (see text)
7. Piece carbon paper, 3" x 4½" (1 required)
8. 3-oz. size Dow Corning marine silicone sealant (2 required)
9. 1-oz. size epoxy glue (1 required)
10. Marine plywood 12" x 12" x ¾" thick (1 required)
11. Soft copper tube, ½" diameter x 2' long (1 required)
12. ¾" diameter x 5' long aluminum electrical conduit (1 required)
13. Bicycle handlebar grip to fit ¾" conduit
14. Assortment (#4 x 40, #6 x 32, #8 x 24) machine screws and nuts

Items numbered 2, 3, 4, and 5 can be purchased at electronic supply stores in most cities, or by mail order from Radio Shack, Lafayette Radio, Allied Radio, or Olson Electronics. (Refer to addresses under Electronic Parts Supply Houses in the back of the book.)

Electronic Parts

In the following list of electronic parts, the left-hand column

contains the symbols for the parts as they appear in the wiring diagrams in this chapter.

<i>Symbol</i>	<i>Description</i>
C1, C5	.1 -microfarad* disc-type ceramic capacitor
c2, C6	.001 microfarad polystyrene capacitor
c3, C7	.01 -microfarad polystyrene capacitor
c4, C8, C13	10-microfarad 15-volt electrolytic capacitor
c9, C10	4.7 picofarad disc-type ceramic capacitor (critical value-refer to text)
C11	.01 microfarad disc-type ceramic capacitor
C12	200 microfarad 6-volt electrolytic capacitor
C14	.22 microfarad disc-type ceramic capacitor
C15	16 picofarad variable capacitor (Burstein-Applebee #12A 1950)
RI, R5	33,000 ohm $\frac{1}{4}$ watt carbon resistor (orange-orange-orange)
R2, R6	47,000 ohm $\frac{1}{4}$ watt carbon resistor (yellow-violet-orange)

All capacitors except C4, C8, C13 & C12 may be rated at 15 volts or more although voltage ratings over 150 volts may produce parts too large to fit on the board.

*The microfarad is one-millionth of a farad, which is the standard unit of capacitance. It is represented in the schematic diagram above as μF . Capacitive values are stenciled on body of each component.

†The picofarad is one-trillionth of a farad. It is represented in the schematic diagram above by the symbol PF. This unit is also known as the micro-microfarad, but picofarad is now more commonly used.

‡The ohm is the standard unit of resistance. Unit values below 1000 ohms are shown in the schematic diagram above by the symbol Ω . Unit values over 1000 ohms are shown by one or more digits followed by K, which indicates a multiplier of 1000. Thus, 47K in the diagram means 47,000 ohms.

§Resistance values are indicated by colored bands or dots on the resistor body. Refer to the legend of the diagram, How Color Band Patterns Are Used to Signify Resistor Size and Grade. The band closest to one end stands for the first digit of the resistance value. The second band from the end stands for the second digit of the resistance value. The third band indicates whether the foregoing digits **must** be multiplied by 10, 100, 1000, 10,000, 100,000, 1,000,000, 1/10, or 1/100 to obtain the total resistance value. As can be seen from the legend, such multiplication usually consists of adding the requisite number of zeros to the first and second digits. The fourth colored band indicates manufacturing accuracy (tolerance) of the stated value. Resistors of 20 percent tolerance are less expensive than those of 5 percent tolerance. Resistors of 10 percent tolerance represent a good cost compromise and are adequate for all purposes in this metal detector circuit.

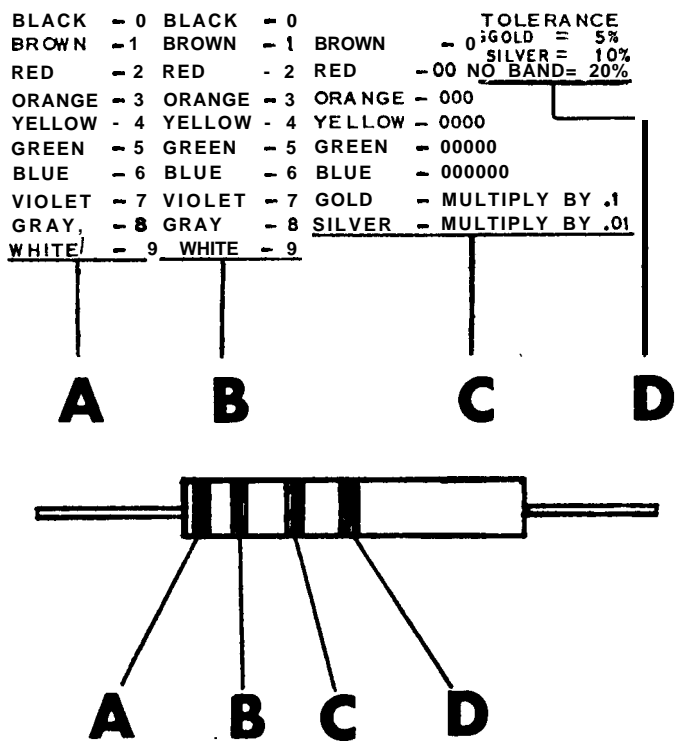

How Color Band Patterns Are Used to Signify Resistor Size and Grade

<i>Symbol</i>	Description
R3, R4, R7, R8, R12, R14	1 000-ohm 1/4 -watt carbon resistor (brown-black-red)
R9	100,000-ohm 1/4 -watt carbon resistor (brown-black-yellow)
R10, R11	1 0,000-ohm 1/4 -watt carbon resistor (brown-black-orange)

<i>Symbol</i>	<i>Description</i>
R13	4700-ohm $\frac{1}{4}$ -watt carbon resistor (yellow-violet-red)
R15	1 0,000-ohm carbon audio volume control with switch (Lafayette #32E22528)
Q1, Q2	silicon PNP transistor (Motorola HEP-7 16) (Radio Shack 2N3638)
Q3, Q4, Q5	silicon NPN transistor (Motorola HEP-729) (RCA 2N2222)
L1	.054 to .50 millihenry* powdered iron core variable inductor (Miller # 6 196A)
L2	search loop (refer to text)
T1	500-ohm primary, 8-ohm secondary, 150-milliwatt transistor-type output transformer (Argonne #AR- 164)
—	9-volt transistor-type battery (Eveready #246 or equivalent)
—	battery connector-snap-fastener for 9-volt battery $\frac{1}{2}$ -inch connector spacing (McGee #BC-9)

Hardware

In the following list of hardware, the **lefthand** column contains the symbols for the parts which appear in the schematic diagram in this chapter.

<i>Symbol</i>	<i>Quantity</i>	<i>Description</i>
PL1	1	female chassis receptacle (Amphenol #80PC-2F)
PL2	1	male cable plug (Amphenol #80MC-2M)
PL3	1	3-circuit phone jack for phone plug PL4 (Little Jax x12-B)

*The millihenry is one-thousandth of a henry, which is the unit of inductance.

<i>Symbol</i>	Quantity	Description
M	1	DC. microammeter, 100 microamps. (Burstein-Applebee #35A6170)
—	4	spacers (H.H. Smith #2102 #6 screw x 3/4" long)
—	1	case (Bud aluminum minibox, 7" x 5" x 3", #CU3008A)
—	3	knobs (Lafayette communication receiver knob #99E6 1053)
—	2	brackets (1/2" x 1" standard cadmium-plated corner reinforcements)
—	1	wire (100 feet #22 thermo-plastic-covered solid hookup wire)
—	1	4 feet #22 2-wire shielded cable (Belden #8422)

Miscellaneous

3/4-inch-wide plastic electronic tape

8-ohm stereo earphones supplied with cord and 3-circuit plug
(Allied Radio Shack #KG-80 1) (Olson #PH-177)

Choice of Solder

Solder, one of the most important supply items, must be chosen with special care. Hardware and large department stores sell several varieties. You must be careful to get the **proper** one. Ordinary radio-TV solder can do the job, but it has drawbacks. Get printed circuit board solder. It is like no other solder available for electronic work and is usually well identified. Look for these specifications:

1. Rosin multicore
2. 18-gage
3. 60-40 tin-lead alloy

Never, under any circumstances, substitute acid core solder. It will completely ruin an electronic wiring job. Common radio-TV solder comes in a 50-50 tin alloy. Using this material risks overheating transistors and resistors, because 50-50 solder requires a high heat to melt the alloy. The 60-40 alloy, however, melts quickly. Heat greatly hampers successful electronic circuit board construction. Selection of the correct solder alloy will help to minimize heating, and a little care in the soldering process will eliminate the problem completely.

Circuit Board Layout”

The etched circuit board is the hub around which everything else grows. Follow directions and you'll be the proud craftsman behind a perfect etching, ready for soldering.

Cut the copper laminate to the exact size shown in Figure 1. Cover it with carbon paper cut to the same size. Make a tracing of the circuit layout from Figure 1 and place this over the carbon sheet. Now retrace the layout so that the pattern appears on the copper laminate in carbon.

Next apply the “resist” enamel from the ball-tip tube. Fill in each area that shows up as black in Figure 1. When this is finished, the copper plate should look exactly like the layout. The only difference will come from the color of the enamel, usually blue. At this point the printed circuit board contains several colored islands surrounded by copper strips. The copper part which remains visible must be removed to create an interconnection pattern for this particular circuit.

*An etched board ready to drill is available from D.L. McClaren, 19721 Maplewood Avenue, Cleveland, Ohio 44135 (telephone 216 267-3263).

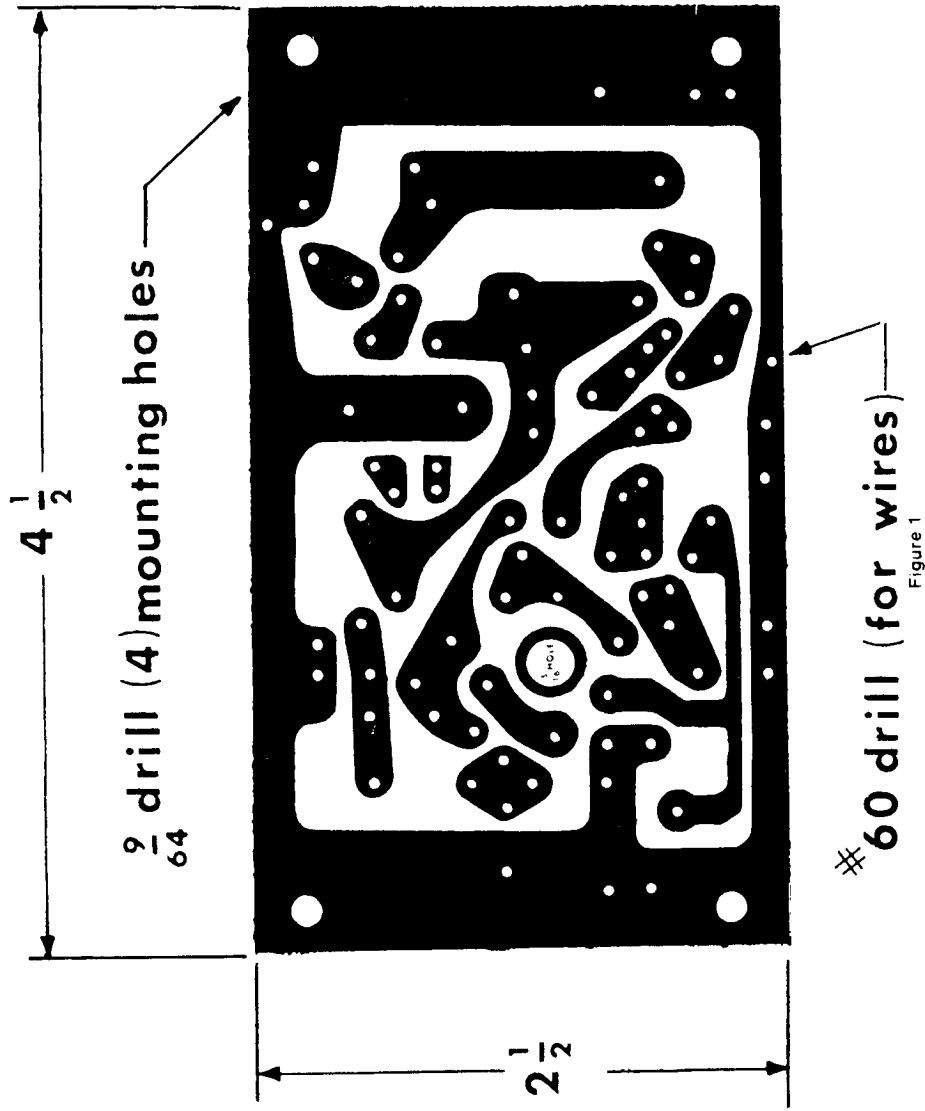

Figure 1

Exact-size view of printed circuit board for metal detector. Observed from bottom of board as the finished etching will appear when viewed directly.

Etching

For the next step, employ a liquid-tight, plastic tray. One inch of depth, more or less, will be fine. An old soup bowl can also be pressed into service, but don't use a metal tray and don't use a container that is cracked or chipped. The tray need not be more than an inch larger all around than the copper circuit board.

Pour the contents of the etchant bottle into the tray and place the copper board, face down, into the liquid at a temperature of 70°-90°F. Handle the etchant with care. It will etch you or your clothing even more quickly than the copper.

Leave the circuit board face down for fifteen minutes. At the end of this period, carefully lift the board from the etchant. (Use the long-nosed pliers but rinse them immediately afterwards.) Examine the etching progress by holding the board in front of a light source. The glass or bakelite will be clearly visible when the copper is completely dissolved, because the etched-out areas will transmit light.

When etching is complete, **re-bottle the etchant** and rinse the board and tray in running water until the water runs clear.

Now remove the enamel resist. Clean it off with paint remover, or scratch it away with a plastic or wooden scraper.

When this step is complete, lightly polish the remaining copper strips with plain steel wool (avoid the soap pads found in every kitchen). Polish just enough to brighten the surface.

Drilling

Now, using Figure I as a guide, drill all the holes shown. Use the #60 drill for component wire holes. Holes that are too small will make it impossible to assemble the component parts. Holes that are too large will complicate the soldering job. Use a 9/64 drill for the corner mounting holes.

Soldering

The circuit board is now ready for parts; so it's time for another word about soldering. The most common fault in electronic kits put together in home shops is known as a cold solder joint. This serious problem results from hasty work. To avoid this kind of trouble, allow the molten solder to flow onto the copper and around the wire lead. When done properly, the solid pyramid of solder will not bulge outward, but will rather tend to curve inward, and the hardened solder alloy will gleam. A *cold* joint will look dull.

Practice with circuit board scraps and small pieces of wire until you get the correct amount of heat combined with the exact amount of solder.

When you are ready to start soldering, install the parts, one at a time, to the top side of the board (Fig. 2). The wire pigtailed will protrude through to the copper underside. Secure each wire with a drop of solder to the copper adjacent to the hole. Double-check polarity of capacitor installation. Match the plus sign appearing on capacitors C4, C8, C12, and C13 with the corresponding plus sign on the circuit board.

When soldering each wire, be careful to avoid heating any part more than necessary, and don't let a solder bridge grow between copper strip conductors. The copper circuit paths run close together and the gaps are easily bridged.

Transistors are especially sensitive to overheating, and those not expert at soldering should use a heat sink when soldering transistors.* It's easy to improvise a heat sink from the tip of the long-nosed pliers. Merely grip each wire on the topside with the pliers as soldering takes place on the underside. The heat will be dissipated in the pliers, with very little getting into the transistor.

Pigtails

Install the interconnection wires next (Figs. 2 and 3) at circuit board points LPI -LP2, PH 1-PH2, S1-S2, SL1 -SL2,

*Transistor sockets may be used.

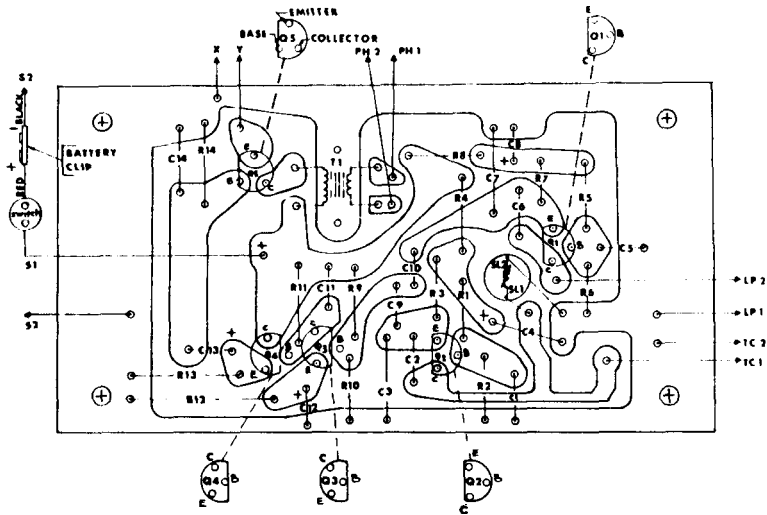

Figure 2

Top view of printed circuit board, showing component parts in position. The copper paths are outlined as though visible from the top to help with part orientation. Transistors are shown in exact location and are also projected outside the board area to help with positioning. Observe the way the flats are located on these epoxy transistors with respect to the PC board. Wires which connect the PC board to case-mounted components are shown with their identifying codes.

TC1 -TC2, and X-Y. Start with wires eight inches long and use a different insulation color for each connection. The board is now ready for final assembly.

The Case

Drill the various component holes in the case, as shown in Figure 4. Use the circuit board for a template to locate the four mounting holes and a single hole for the slug-tuned coil stem. Locate the remaining holes from the dimensions in Figure 4. When this step is complete, all is ready for starting final assembly.

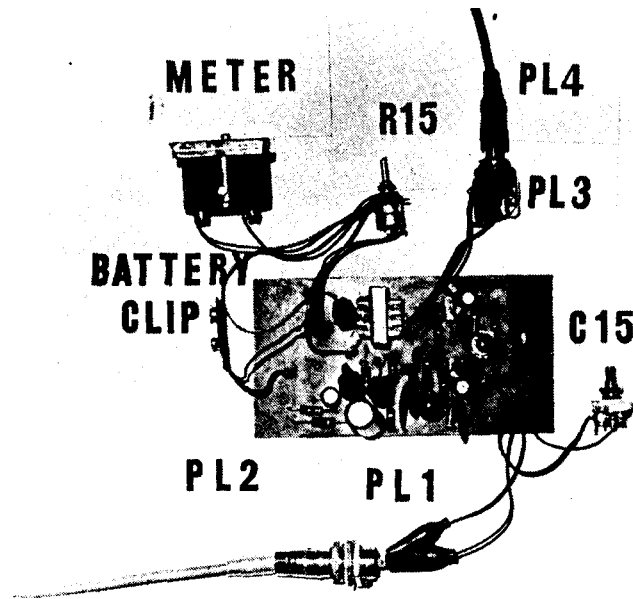

Figure 3

Printed circuit board, showing **pigtail** wires end attachments.

Earphone Connection

For improved hearing and increased comfort the earphone specified are stereo type. A three circuit plug is standard with stereo phones and a three circuit jack is required to put them to use without alteration. (Use these same earphones for stereo FM, etc.) The detector amplifier is single-ended, which is another way of saying it has a monaural output. A shorting link (jumper) converts the stereo 3 circuit jack to monaural 2 circuit. (Fig. 5)

Superior hearing can be expected from stereo earphones because they have a much wider frequency response than that of the professional radio operator type generally supplied with

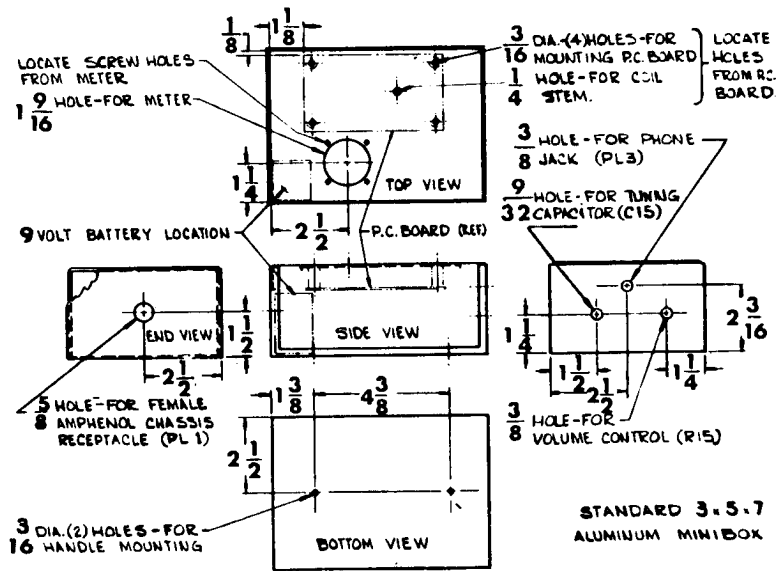

Figure 4

Guide for drilling holes in case.

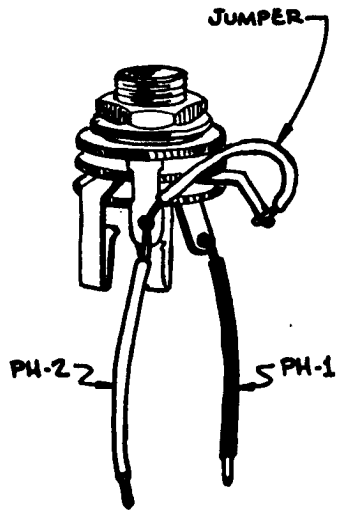

Figure 5

Stereo earphone jack modification detail.

metal detectors. Also, stereo headphones are made to be comfortable even when worn for several hours. The foam pads are soft and the large cushion around each ear makes a remarkably effective acoustic seal. No matter how noisy the surrounding environment, this type of headphone will greatly reduce all sound except the growl of the detector.

There is one precaution to observe in selecting headsets for use with this electronic package. Do not substitute a 2000 ohm (high impedance) model for the 8 ohm headset specified. The high impedance type will cause the sound output level to drop noticeably.

Suitable low cost, 8 ohm headphones are commonly available wherever phonograph records are sold. They are also available by mail from Olson Electronics, Lafayette Radio and Radio Shack. Send for their catalogs and make your choice.

Hardware Installation

Install the prepared phone jack and the Amphenol #80PC-2F female receptacle in the lower case unit. Next install the fine tuning capacitor (C15) and the volume control (R15). This completes assembly of the lower unit.

The meter is next to be assembled. It should fit the $1\frac{9}{16}$ inch hole cut in the upper case with room to spare. Fasten it securely with the nuts provided and proceed to the PC board installation.

The circuit board is supported on the inner surface of the case by four spacers and secured by four #6 x 32 x 1 inch machine screws. When the circuit board is in position the brass adjusting screw of the tuning coil (L 1) will protrude through the case approximately $\frac{1}{8}$ ". Cement a small plastic washer to the case at this point to protect the adjusting screw from damage.

This completes the upper case assembly. Next, interconnect the controls and the receptacle located in the lower case,

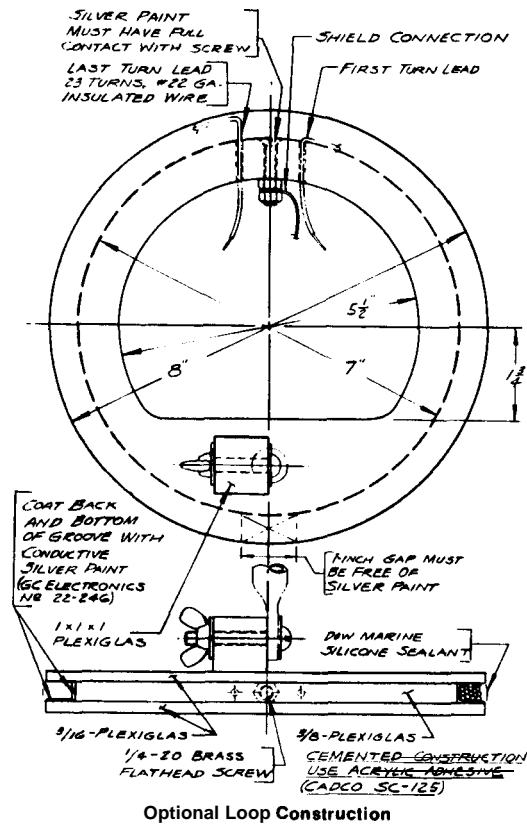

to wires previously assembled to the circuit board. Make the connections as follows:

Battery (9-volt): negative wire from battery connector to point S2 on PC board. Connect positive (+) wire to one switch terminal.

Variable capacitor (C1 5): connect **stator** to wire from point TCI. Connect rotor to wire from point TC2.

Slug-tuned coil (L1): one connection to wire from point SL1; one connection to wire from point SL2.

- Meter (M): one connection to wire from point X. Add one wire and connect to volume control (R15) center terminal.
- Chassis receptacle (PL1): one connection to wire from point LP1; one connection to wire from point LP2.
- Phone jack (PL3): one connection to wire from point PH1; one connection to wire from point PH2.
- Volume control (R15): one connection to wire from point Y; one connection to wire from meter (M).
- Switch (mounted on R15): one connection to wire from point S1; one connection to positive wire from battery connector.

Make the meter connections as shown in Figure 6. If the meter works backward, simply reverse the connections.

The easiest method for a permanent battery installation is

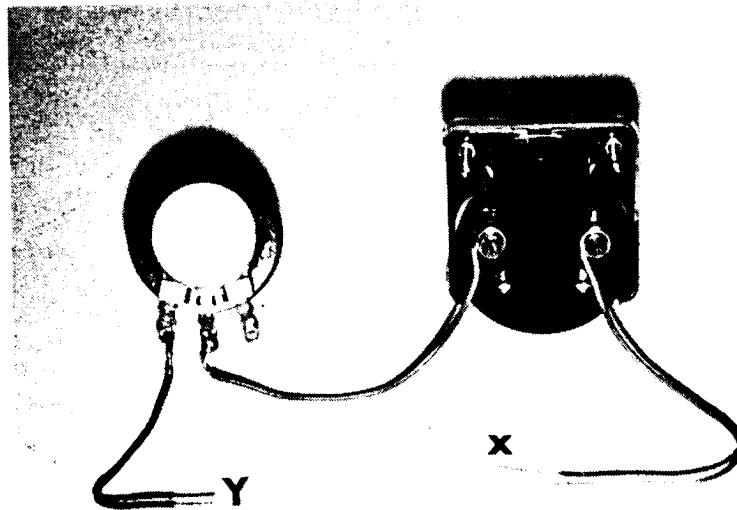

Figure 6
Meter connections.

to simply epoxy it in place. The recommended battery will last about 100 hours, and that's a lot of time in the field. To replace a battery, simply dislodge the old battery with a screwdriver and glue the new one in place.

The control head is now complete and can be bolted to the handle. Be careful of the wires which run all over the interior. Don't accidentally pull one off while attaching the case to the handle. Next comes the search loop. When it is finished, the detector will be complete.

Search Loop*

Observing three critically important requirements will ensure successful search loop construction.

1. The correct *length* of wire wound into the coil.
2. The need to securely anchor the coil to prevent the individual wires from moving.
3. The use of a Faraday shield to minimize capacitance coupling with the earth.

None of the remaining construction details are critical. Design can be varied to suit individual needs, but don't ignore the three basic specifications. The following method, however, is quick and certain (Fig. 7).

First, cut the $\frac{3}{8}$ -inch marine plywood square into an 8-inch diameter circle. Bore a 1-inch hole in the exact center. Next, prepare the copper Faraday shield by bending the 24-inch length of $\frac{1}{2}$ -inch *soft* copper tube around the plywood circle. The air gap between the ends of the copper tube is intended. Do not close this gap, as the operation of the loop depends upon it.

After forming the tube into a circle, place it in a vise and split the outside wall for the full length of the tube. Now open the saw cut to form a "Y-shaped section, also the full length of the tube. Lightly burnish the copper with steel wool. Next, slip this "C"-section ring over the plywood disc

*For test purposes, a coil identical to **11** (use a second Miller 6196A) can be substituted for the search loop.

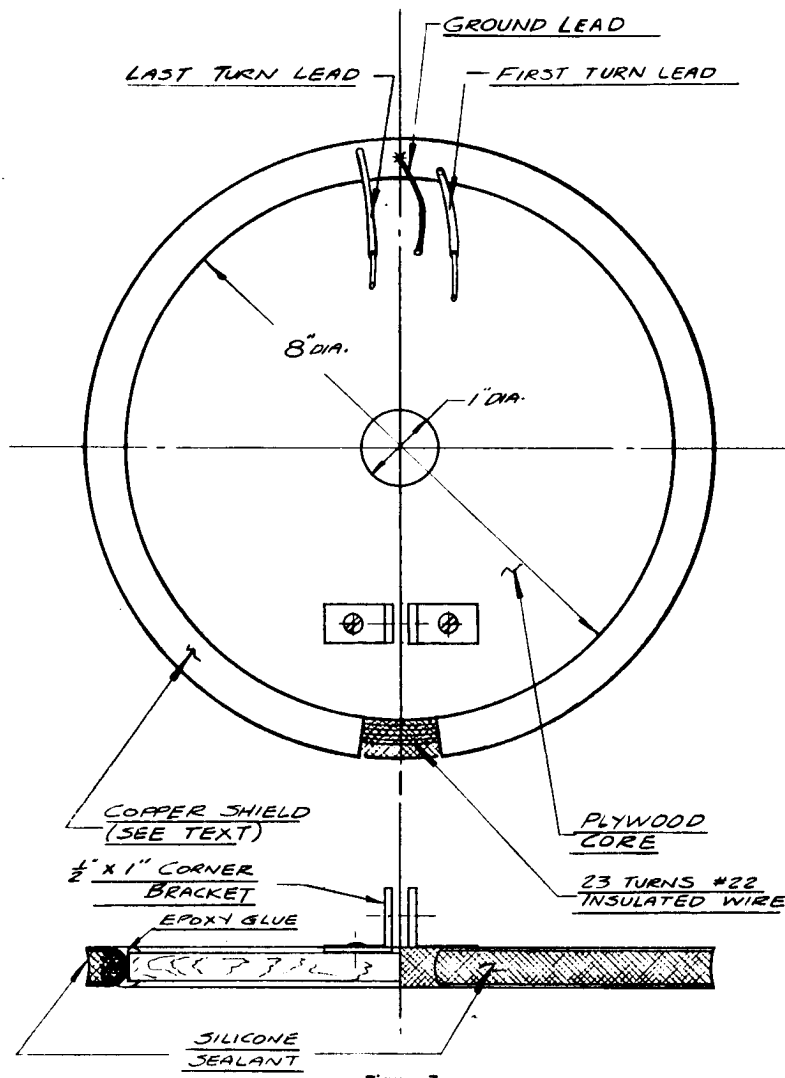

Figure 7

Refer to illustration on page 107 for alternate loop construction.

and, **using** epoxy glue, secure the ring to the plywood. Allow the epoxy resin time to cure (usually 24 hours) before **proceeding to the next step.**

When the glue is well set, drill two 1/16-inch diameter holes in the top surface of the copper ring, exactly opposite the gap. Solder a 4-inch length of bare wire 1/2 inch distant from the holes in the copper ring. **The next step is to wind the search coil.**

Litz wire is best for radio frequency coil building because it presents the most area for radiation, although its extreme fragility makes soldering difficult. A coil made **of Litz** wire is the ultimate. Order Belden #88 17. Magnet wire is a good second choice, but its sensitivity to abrasion may result in a **break** in the thin insulation that will prevent the loop from operating. We recommend, instead, #22 thermoplastic-covered hookup wire as the best choice for a first-time attempt at constructing a loop. **This** wire is Belden #8530.

You will need 48 feet of wire, whatever the kind. **Wind the** coil clockwise, but first run the free end of the first winding through one of the two 1/16-inch diameter holes in the copper ring. **Tape the** loose end temporarily to the plywood center disc and proceed to wind twenty-three turns around the copper trough. Use plenty of tension. Keep the windings tight.

Complete the twenty-third turn, clip the wire three inches longer than needed to complete the last turn and run the free wire end through the second 1/16-inch diameter hole in the copper ring. Twist the two free ends together to keep everything tight.

The next step is connecting to the shielded 2-wire cable which plugs into the control head (Belden #8422). First solder the braided shield to the bare wire connected to the copper ring. Next solder the two insulated conductors to the two free ends of the coil. Don't apply sealing material before testing the loop assembly.

To make the check, attach the handle to the loop (see **As-**

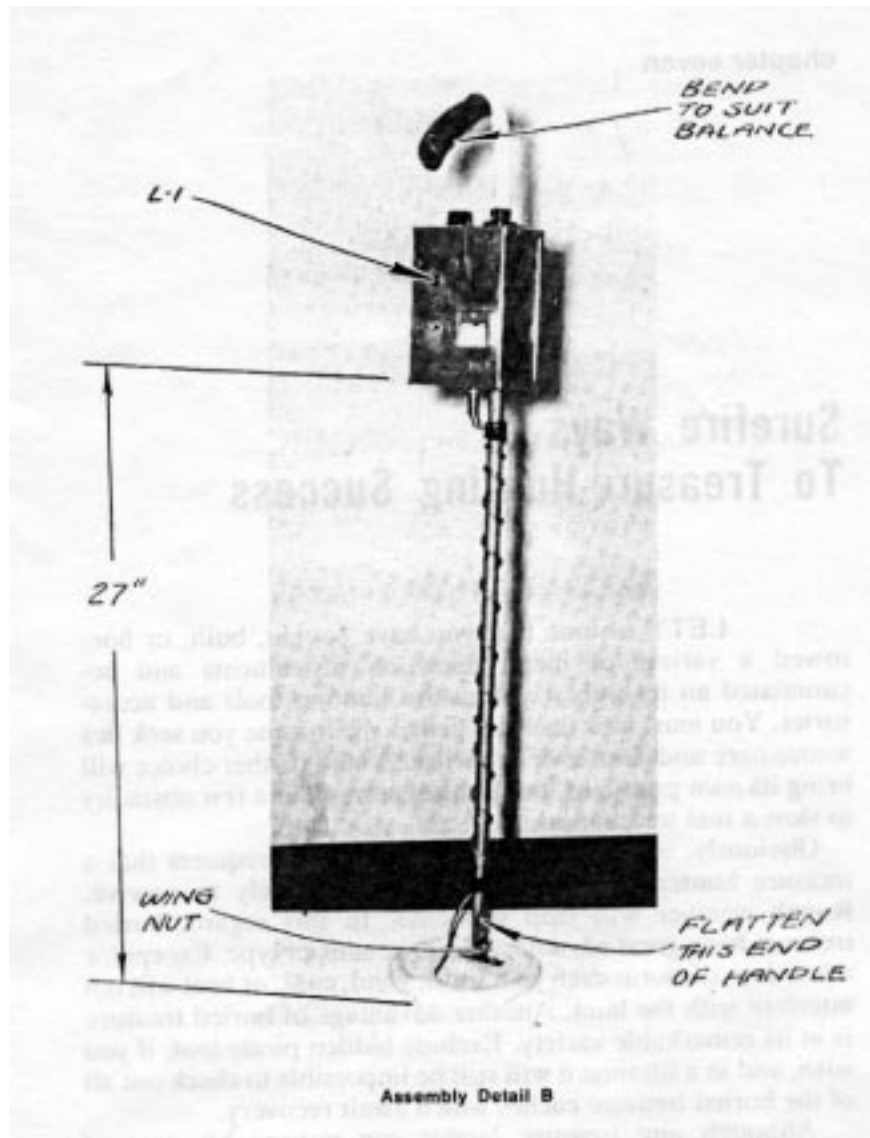

sembly Detail B) and plug in the lead wire at the control head. Plug in the headset and turn the switch on.

Using a small screwdriver, turn the tuning coil slug slowly until a loud tone sounds in the earphones. There will be silence at any other tuning position. Set the tuning capacitor at half-mesh when the coil slug is set in the null or silent half-turn between tone sounds.

The tuning slug can be set to get a rising tone or a descending tone when metal is detected. Be sure to set it for the rising tone. When the instrument is performing properly, use the marine sealant to seal off and immobilize the search coil windings. Don't be skimpy with the sealant. The wires *must* be locked securely. Covering the wire solder joints on the search loop with the same material finishes the job, except for paint.

When the sealant has cured, paint the entire coil with several coats of good white outside enamel. The white color will reflect the sun and keep rapid temperature changes from affecting the signal stability. Do not use aluminum or any other metalized paint.

Field Trials

This metal detector is an excellent instrument. A little practice will soon result in a cash return on your investment. Just remember these precautions.

1. The main tuning and fine tuning controls can be set to indicate metal presence with an upswing of sound pitch or a downswing of sound pitch. Always set the controls to produce an upswing of tone pitch. The basic tone should be very low in pitch, but as ears differ in sensitivity, some personal choice is involved here.

2. Keep the search loop close to the ground. This will put a maximum amount of radio frequency energy into the search

area. A large air gap between the earth and the search loop wastes the signal radiating from the search coil.

3. When you prefer not to wear the earphones over your ears, simply carry them around the neck and turn up the volume. The low-impedance stereo phones employ small speakers as reproducers and eliminate the need for installing a separate speaker in the case.

4. When using the meter, set the needle at midscale or lower. Keep your eyes fixed on it while slowly scanning the search area.

Troubleshooting*

Following instructions should eliminate any difficulty in getting this project to operate. There are, however, some problems which can occur, as with all electronic devices.

The cold solder joint causes lots of trouble. The only cure for this defect is resoldering.

Check for wrong part installation, reversed negative and positive orientation of capacitors, and check resistor installation. It is possible to transpose the color band arrangement in your mind and thus misplace one of these parts.

Make certain that all interconnection wires are installed and be certain of battery voltage!

"DC VOLTAGE CHART			
	EMITTER	BASE	COLLECTOR
Q1	5.0	4.4	0.0
Q2	5.0	4.4	0.0
Q3	0.16	0.76	7.4
Q4	7.1	7.4	9.0
Q5	0.0	0.0	9.0

All voltages shown are positive polarity. Before making voltage tests, set R15 at minimum resistance and short out coils L1 and L2. These readings were taken with a vacuum tube volt/ohmmeter, but a 20,000 ohms per volt multimeter will provide the required accuracy. All readings may vary plus or minus 20% due to component tolerance stack."

*With some low activity transistors the value of Capacitors C9 and C10 may need to be increased. If voltages check okay and the beat note cannot be heard, increase C9 and C10 to 120 pf.