

**Part Two. US Scatterable Mines****CHAPTER 6**  
**SCATTERABLE MINES AND MINE SYSTEMS**

*Scatterable mines are laid without regard to classical pattern. They are designed to be delivered or dispensed remotely by aircraft, artillery, missile, or ground dispenser. All scatterable mines have a limited active life and self-destruct after their active life has expired. The duration of the active life varies with the type of mine and delivery system.*

*Scatterable mine systems enable the tactical commander to emplace minefields in enemy-held or contaminated territory, or in other areas where it is impossible to emplace conventional minefields. Some systems allow for rapid emplacement of minefields in friendly areas. As with all minefields and obstacles, scatterable minefields are an engineer responsibility.*

*Based on the tactical plan, the maneuver commander's staff engineer determines the location, size, time, and density of the minefield. With this information and a thorough understanding of available systems, he recommends the type minefield to be emplaced [conventional or scatterable]. If a scatterable minefield is selected, he recommends the delivery system and coordinates with the appropriate staff officers.*

**GENERAL CHARACTERISTICS**

Most scatterable mines have similar (generic) characteristics. With the exception of the ADAM, standard scatterable AP and AT mines have a cylindrical shape and size (approximately 4.75 inches in diameter by 2.6 inches in height). (See Figures 6-1 and 6-2, page 6-2.) Scatterable mines are much smaller in size and weight than conventional mines. A standard scatterable AT mine weighs approximately 4 pounds and has 1.3 pounds of explosive; an M 15 conventional mine weighs 30 pounds and has 22 pounds of explosive. Arming mechanisms, arming times, and self-destruct times of scatterable mines differ based on the dispensing system and the chosen self-destruct time.

**Antipersonnel Mines**

There are two general categories of scatterable AP mines: wedge and cylindrical (Figure 6-1). Table 6-1, page 6-3, summarizes the characteristics of each type scatterable AP mine. The types of scatterable AP mines are—

- M67 and M72 AP mines (artillery-delivered).
- M74 AP mine (GEMSS- and Flipper-delivered).
- BLU 92/B AP mine (US Air Force-delivered).
- M77 AP mine (MOPMS-delivered).
- Volcano AP (ground or air Volcano-delivered).

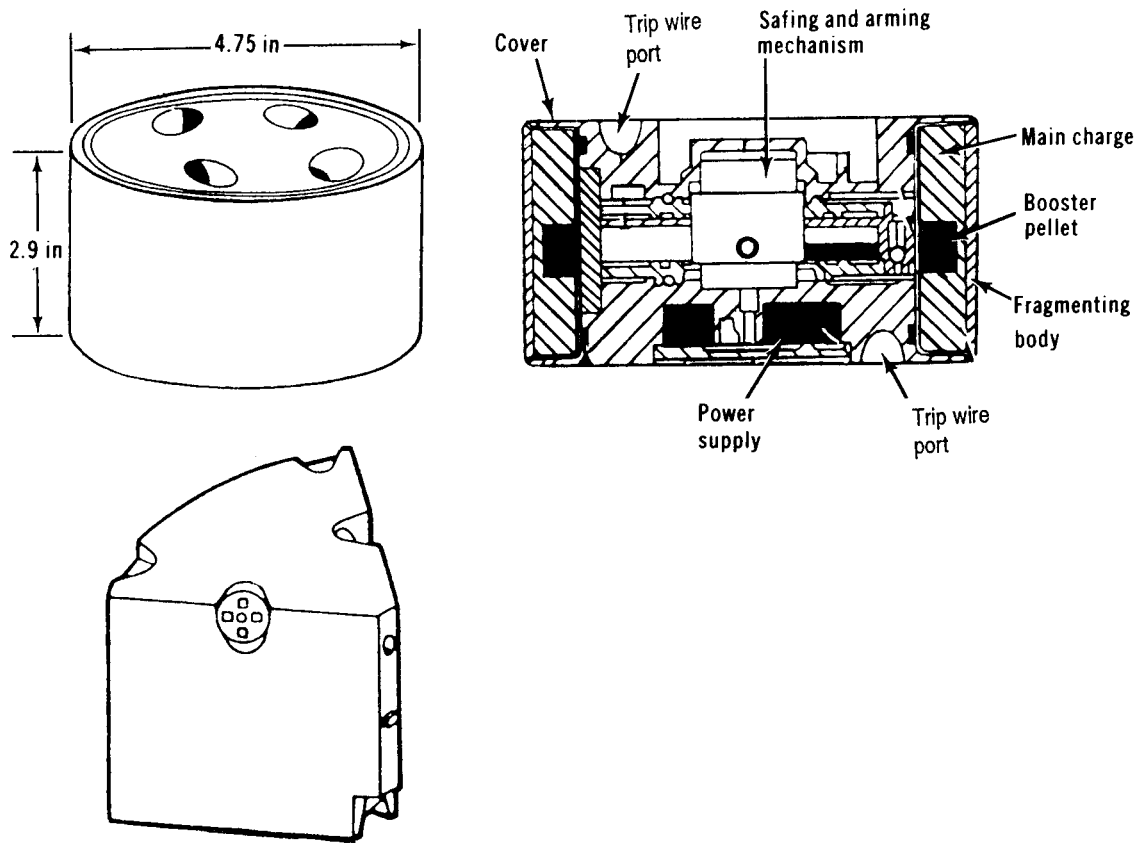

Figure 6-1. Antipersonnel mines

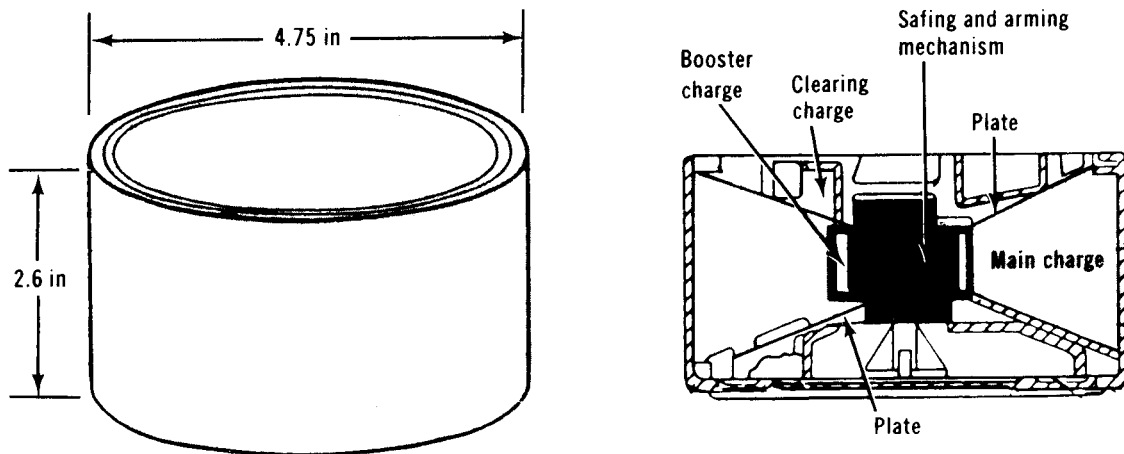

Figure 6-2. Antitank mine

★ **Table 6-1. Scatterable AP mine characteristics**

| Mine     | Delivery system         | Arming mechanism      | Safe arm time   | Fuzing    | Warhead           | AHD  | Self-destruct time              | Explosive weight | Mine weight (lb) | Mines per 5-ton dump      |
|----------|-------------------------|-----------------------|-----------------|-----------|-------------------|------|---------------------------------|------------------|------------------|---------------------------|
| M72      | 155 mm artillery (ADAM) | 1-G force 2-spin      | 45 sec<br>2 min | Trip wire | Bounding fragment | 20%  | 48 hr                           | 21 grams Comp A5 | 1.2              | 36 per M692               |
| M67      | 155 mm artillery (ADAM) | 1-G force 2-spin      | 45 sec<br>2 min | Trip wire | Bounding fragment | 20%  | 4 hr                            | 21 grams Comp A5 | 1.2              | 36 per M731 projectile    |
| M74      | GEMSS Flipper           | 1-spin 2-electric     | 45 min          | Trip wire | Blast fragment    | 20%  | 5 days<br>15 days               | 1.2 lb Comp B4   | 3.2              | 1,600                     |
| BLU 92/B | USAF (Gator)            | 1-bore pin 2-electric | 2 min           | Trip wire | Blast fragment    | 100% | 4 hr<br>48 hr<br>15 days        | 1.2 lb Comp B4   | 3.2              | NA                        |
| M77      | MOPMS                   | 1-bore pin 2-electric | 2 min           | Trip wire | Blast fragment    | 0%   | 4 hr<br>(recycle up to 3 times) | 1.2 lb Comp B4   | 3.2              | 30 modules (120 mines)    |
| Volcano  | Ground/Air              | Crystal oscillator    | 4 min           | Trip wire | Blast fragment    | 0%   | 4 hr<br>48 hr<br>15 days        | 1.2 lb Comp B4   | 3.2              | 160 canisters (160 mines) |

★ The M67 and M72 are wedge-shaped AP mines that are dispensed from an ADAM projectile, which is a special 155-millimeter artillery munition. Each mine weighs 1.2 pounds and is 2.75 inches high.

The M74, BLU 92/B, M77, and Volcano AP mines are all cylindrical-shaped. They are 2.6 inches high and 4.75 inches in diameter. Cylindrical AP mines kill enemy soldiers through the combined effects of blast and fragmentation. Each mine contains 0.9 pound of Composition B4 as its main charge. The charge detonates upon actuation and shatters the mine's metal casing to produce shrapnel. Shrapnel is propelled upward and outward from the mine and produces fatal casualties to a distance of 15 meters. Each mine has eight trip wires (four on the top and four on the bottom) that deploy after ground impact up to 40 feet from the mine. Trip wires are similar in appearance to very fine fishline, and they are weighted at one end. Tension of 0.9 pound applied to one trip wire is enough to create a break in an electrical circuit and cause the mine to detonate.

### Antitank Mines

All scatterable AT mines (except the M56 helicopter -delivered mine) have similar functional characteristics. They are cylindrical in shape, weigh approximately 4 pounds, contain 1.3 pounds of cyclonite (RDX) explosive as the main charge, and have a magnetic-induced fuze (Figure 6-2, page 6-2). The characteristics of each specific type of scatterable AT mine are summarized in Table 6-2, page 6-4. The types of mines include—

- M70 and M73 AT mines (artillery-delivered).
- M75 AT mine (GEMSS- and Flipper-delivered).
- BLU 91/B (US Air Force-delivered).
- M76 (MOPMS-delivered).
- Volcano AT (ground or air Volcano-delivered).

★ Scatterable AT mines are designed to produce a K-Kill (kill the crew of the vehicle) instead of an M-Kill. The mine produces a kill by using an SFF warhead (also called an M-S SFF plate). The warhead penetrates the vehicle's belly armor,

★ *Table 6-2. Scatterable AT mine characteristics*

| Mine     | Delivery system         | Arming mechanism         | Safe arm time   | Fuzing   | Warhead   | AHD | Self-destruct time              | Explosive weight (lb) | Mine weight (lb) | Mines per 5-ton dump      |
|----------|-------------------------|--------------------------|-----------------|----------|-----------|-----|---------------------------------|-----------------------|------------------|---------------------------|
| M723     | 155 mm artillery (RAAM) | 1-G force<br>2-spin      | 45 sec<br>2 min | Magnetic | M-S plate | 20% | 48 hr                           | 1.3 RDX               | 3.8              | 9 per M718 projectile     |
| M70      | 155 mm artillery (RAAM) | 1-G force<br>2-spin      | 45 sec<br>2 min | Magnetic | M-S plate | 20% | 4 hr                            | 1.3 RDX               | 3.8              | 9 per M741 projectile     |
| M75      | GEMSS Flipper           | 1-spin<br>2-electric     | 45 min          | Magnetic | M-S plate | 20% | 5 days<br>15 days               | 1.3 RDX               | 3.8              | 1,600                     |
| BLU 91/B | USAF (Gator)            | 1-bore pin<br>2-electric | 2 min           | Magnetic | M-S plate | No  | 4 hr<br>48 hr<br>15 days        | 1.3 RDX               | 3.8              | NA                        |
| M76      | MOPMS                   | 1-bore pin<br>2-electric | 2 min           | Magnetic | M-S plate | No  | 4 hr<br>(recycle up to 3 times) | 1.3 RDX               | 3.8              | 30 modules (510 mines)    |
| Volcano  | Ground/Air              | Crystal oscillator       | 2 min<br>30 sec | Magnetic | M-S plate | No  | 4 hr<br>48 hr<br>15 days        | 1.3 RDX               | 3.8              | 160 canisters (800 mines) |

and spalling metal from the vehicle (created by the mine blast or secondary explosives) kills occupants instantly. On enemy tanks with autoloaders, detonation of rounds in the belly-mounted ammunition carousel is very likely. The mine may not achieve a kill when the track of an armored vehicle runs directly over it. Also, due to the concentrated area of the blast, it is possible that an armored vehicle may continue to move. Even though the crew is killed, the drive train may be undamaged.

- ★ The magnetic fuze is designed to detonate as the magnetic field peaks over the mine. The warhead is bidirectional, meaning that it can fire from the top or the bottom. The M70/M73 (RAAM) and M75 (GEMSS/Flipper) also have anti disturbance devices built into 20 percent of the AT mines. While the Volcano AT, MOPMS AT, and BLU 91/B (Gator) do not have antidisturbance devices, they will self-destruct when moved due to a change in their orientation to the earth's magnetic field. While this feature was not expressly designed as an antidisturbance device, it accomplishes the same function

Due to their small size, reduced explosive, and possibility of landing with an improper orientation (on their side or at an angle), scatterable AT mines have less chance of killing a vehicle than a conventional full-width AT mine. An armored vehicle will not always be destroyed after an encounter with a scatterable AT mine. Further, the effectiveness of scatterable mines in water obstacles is reduced even more, because 2 inches of water prevents the formation of the M-S slug. Although the blast wave is accentuated by underwater placement (attacking hatches and covers), mining of banks and approaches is recommended instead.

The M56 helicopter-delivered mine (Figure 6-3) is an AT blast mine that produces an M-Kill on wheeled or tracked vehicles. Each mine resembles a cylinder that is split in half lengthwise. The mine weighs 5.9 pounds, is approximately 10.4 inches long, and is 2.3 inches high. It utilizes an electrical/mechanical pressure fuze and an HE blast warhead. Pressure between 49 and 200 pounds is required for actuation. The M56 functions underwater as long as the water pressure does not exceed the actuation pressure. Some mines

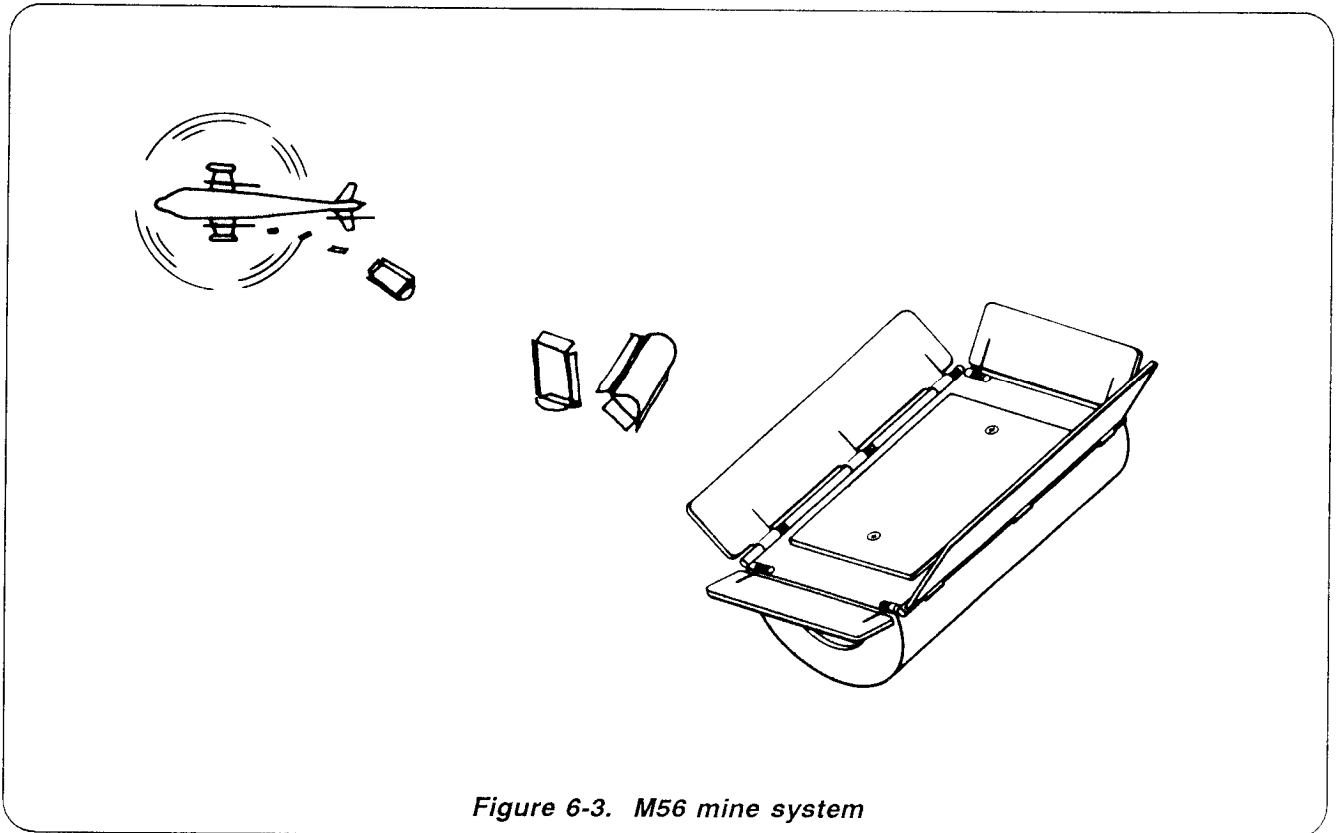

Figure 6-3. M56 mine system

have antidisturbance features. This system is currently being replaced by the air Volcano

and is being phased out of the inventory.

## CAPABILITIES

**Faster response.** Scatterable mines can be emplaced faster than conventional mines, so they provide the commander with greater flexibility, and they can be used to react to changes in situations. The commander can use scatterable mines to maintain or regain the initiative by acting faster than the enemy. This also helps preserve scarce mine resources.

**Remote emplacement.** Scatterable mines are remotely emplaced. This enhances battlefield agility and allows the maneuver commander to rapidly emplace mines to best exploit enemy weaknesses. Scatterable mines can therefore be used as a situational obstacle; as a reserve obstacle emplacement capability; and to directly attack enemy formations through disrupt, fix, turn, and block. Modern fuzing, sensing, and antidisturbance devices allow scatterable

mines to better defeat enemy attempts to reduce the minefield.

**Increased tactical flexibility.** Upon expiration of the self-destruct time, the minefield is cleared, and the commander can move through an area that was previously denied to enemy or friendly forces. In many cases, the self-destruct period may be set at only a few hours. This feature allows for effective counterattacks to the enemy's flanks and rear areas.

**Efficiency.** Scatterable mines can be emplaced by a variety of delivery methods. They can be deployed by fixed-wing aircraft, helicopters, artillery, or ground vehicles. They satisfy the high-mobility requirements of modern warfare. Manpower, equipment, and tonnage are reduced for their emplacement.

**Increased lethality.** Scatterable AT mines utilize an SFF created from a two-sided M-S plate charge to produce a full-width kill. In simple terms, a metal plate is formed into a super-dense molten rock that punches a hole in the belly of the tank. This produces an M-Kill against the vehicle engine, track, or drive train; a firepower kill against the vehicle weapon system; or a K-Kill in which the on-board ammunition is set off and the crew is killed or incapacitated. The scatterable AT mine is

designed to kill any tank in the world. In order to form the SFF, the mine requires a standoff between the vehicle and the target. Mines must also be nearly perpendicular to the target (lying on either side). Because the M-S plate is two-sided, the mine will successfully attack the target while lying on either side. Scatterable AP mines are actuated by trip wires and utilize a blast/fragmentation-type kill mechanism. Scatterable mines are much smaller and lighter than conventional mines.

## LIMITATIONS

**Extensive coordination.** Because scatterable mines are very dynamic weapon systems, great care must be taken to ensure proper coordination is made with higher, adjacent, and subordinate units. To prevent friendly casualties, all affected units must be notified of the location and duration of scatterable minefields. Recording and reporting procedures for scatterable mines are specifically designed to help minimize this problem.

**Proliferation of targets.** Scatterable mines may be regarded by some commanders as an easy solution to tactical problems. Target requests must be carefully evaluated, and a priority system must be established. Indiscriminate use of weapon systems results in rapid depletion of a unit's basic load. Controlled supply rates (CSRs) will probably be a constraint in all theaters.

**Visibility.** Scatterable mines are very effective, even though they lie exposed on the surface of the ground. They are relatively small and have natural colorings. Scatterable mines are highly effective, especially when fires and

obscurants strain the enemy's command and control.

**Accuracy.** Scatterable mines cannot be laid with the same accuracy as conventional mines; however, their self-destruct capability eliminates the need for recovering them. Remotely delivered scatterable mine systems are as accurate as conventional artillery or tactical aircraft-delivered munitions.

**Orientation.** Between 5 and 15 percent of scatterable mines will come to rest on their edge. Mines with spring fingers will be in the lower percentile. If there is mud or snow more than 10 centimeters deep, mines will be in the higher percentile. Classified lethality data provides for 10 percent of scatterable mines to rest on their edge. When employing the ADAM and the RAAM in over 10 centimeters of snow, high-angle fire is used and the number of mines is increased. AP mines may be less effective in snow, because the deployment of trip wires is hindered. Melting snow may also cause mines to change position and activate antidisturbance features.

## SCATTERABLE LIFE CYCLE

All scatterable mines have a similar life cycle, although specific times vary based on the self-destruct time and the dispensing system. The life cycle is as follows:

- At launch, all mines must receive two arming signals for safety reasons. Usually, one signal is physical (spin, acceleration, or unstacking) and the other is electronic. This

- same electronic signal sets the mine self-destruct time.
- ★ • Upon receiving arming signals, mines start their arming (or safe separation) countdown. Mines are still in flight. This allows them to come to rest and allows the dispenser to exit safely. Arming time for most mines is two minutes. Arming time for the GEMSS is 45 minutes, and newer model ADAM and RAAM rounds (with an AI suffix) have a 45-second safe separation arming delay. Volcano mines from the M87A1 canisters have a delay time of 2 minutes 30 seconds to 4 minutes.
  - Mines are armed after the arming countdown. The first step in arming is a self-test to ensure proper circuitry. Approximately 0.5 percent of the mines fail the self-test and self-destruct immediately.
  - ★ • After the self-test, mines remain active until their self-destruct time expires or until they are encountered. Mines actually self-destruct at 80 to 100 percent of their self-destruct time. The time period from when the mines begin to self-destruct and when they finish is called the *self-destruct window*. When the full self-destruct time is reached, no mines should remain. The probability of a live mine existing past its self-destruct time is 1 in 10,000. Mines that remain are duds. They are inoperative due to battery run-down, but should be treated as unexploded ordnance. Mines with a 4-hour self-destruct time will actually start self-destructing in 3 hours 12 minutes. When the 4-hour self-destruct time is reached, no unexploded mines should exist. The self-destruct times of US scatterable mines are shown in Tables 6-1 and 6-2, pages 6-3 and 6-4.

## LETHALITY AND DENSITY

**Lethality and tactical obstacle effect.** Scatterable minefields are employed to reduce the enemy's ability to maneuver, mass, and reinforce against friendly forces. They increase the enemy's vulnerability to fires by producing specific obstacle effects on the enemy's maneuver (disrupt, fix, turn, and block). To achieve this aim, individual minefields must be emplaced with varying degrees of lethality. During emplacement, minefield lethality is varied primarily by changing its density. Therefore, there is a direct correlation between obstacle effect and minefield density. The following guidance is provided for use in choosing an appropriate density for individual minefields to achieve the tactical obstacle effect:

- *Disrupt:* Low density; 40-50 percent probability of encounter; linear density between 0.4 and 0.5 mine/meter front.
- *Fix:* Medium density; 50-60 percent probability of encounter; linear density between 0.5 and 0.6 mine/meter front.
- *Turn:* High density; 75-85 percent probability of encounter; linear density between 0.9 and 1.1 mine/meter front.

- *Block:* High density; 85 percent and higher probability of encounter; linear density higher than 1.1 mines/meter front.

**Density.** Density is normally expressed as *linear* or *area* density. For conventional mines, linear density is normally used and is expressed in the average number of mines per meter of minefield front. For scatterable mine systems, area density is normally used and is expressed in the average number of mines per square meter. Since scatterable mine systems normally employ a preset combination of AT and AP mines, the area density includes both. For example, a scatterable minefield with an area density of .006 mine/square meter may have an AT density of .004 AT mine/square meter and an AP density of .002 AP mine/square meter.

*Linear density* equals the number of mines divided by the frontage of the minefield.

$$\frac{\text{Number of mines}}{\text{front length (m)}} = \text{mines per meter of front}$$

*Area density* equals the number of mines divided by the minefield area (front times depth) in square meters.

$$\frac{\text{Number of mines}}{\text{front} \times \text{depth}} = \text{mines per square meter}$$

Area density can be converted to linear density by multiplying the area density by the minefield depth.

$$\text{Area density} \times \text{depth (meters)} = \text{linear density}$$

EXAMPLE: A 65- x 200-meter Gator minefield contains 564 mines (432 ATs and 132 APs).

- Overall area density:  $564 / (200 \times 650) = .004$  mine per square meter.
- AT area density:  $432 / (200 \times 650) = .003$  AT mine per square meter.
- AP area density:  $132 / (200 \times 650) = .001$  AP mine per square meter.

Overall linear density:  $564 / 650 = .87$  mine per meter front.

AT linear density:  $432 / 650 = .67$  AT mine per meter front.

AP linear density:  $132 / 650 = .2$  AP mine per meter front.

#### NOTES:

**1. AT area density plus AP area density equals the overall area density; AT area density plus AP linear density equals the overall linear density.**

- ★ **2. Converting area density to linear density is not always accurate due to the space between minefield strips (mines/meter of front).**

## SCATTERABLE MINE EMPLOYMENT AND EMPLACEMENT

Employment considerations and emplacement techniques and procedures differ for each type of mine and delivery system. This section discusses the characteristics of each delivery system and provides tactical considerations for the employment of each system on the battlefield. Techniques and procedures for emplacing minefields intended to disrupt, fix, turn, and block are also discussed, and they build on the tactical obstacle design principles developed in Chapter 2.

### ADAM/RAAM

ADAM and RAAM mines (Figure 6-4) are delivered by a 155-millimeter howitzer. No special modifications or adaptations are required for the firing system. Mines are contained within a 155-millimeter projectile and dispensed while in flight. The effective range of an M 109 howitzer is 17,500 meters, and the effective range of an M 198 howitzer is 17,740 meters.

The M692 (long duration) and M731 (short duration) ADAM projectiles deliver AP mines with different self-destruct times. Each ADAM artillery round contains 36 mines. The M731/M731A1 round contains M72 AP mines with a 4-hour self-destruct time; the M692/M692A1 round contains M67 AP mines with a 48-hour self-destruct time. Self-destruct times are preset during the manufacturing process and cannot be changed.

In either case, the wedge-shaped ADAM mine is a bounding fragmentation mine that deploys up to seven tension-activated trip wires 6 meters away from the mine. After ground impact, trip wires are released and the mine is fully armed. The ADAM contains a metal-jacketed sphere that is filled with 21 grams of Composition A5 as its main charge. A liquid explosive propelling charge positions itself at the bottom of the sphere after ground impact. Once the ADAM is jarred, tilted, or a tension of 0.9 pound or more is applied to one or more of the trip wires, the sphere propels upward 2 to 8 feet and detonates. The lethal casualty radius is between 6 and 10 meters.



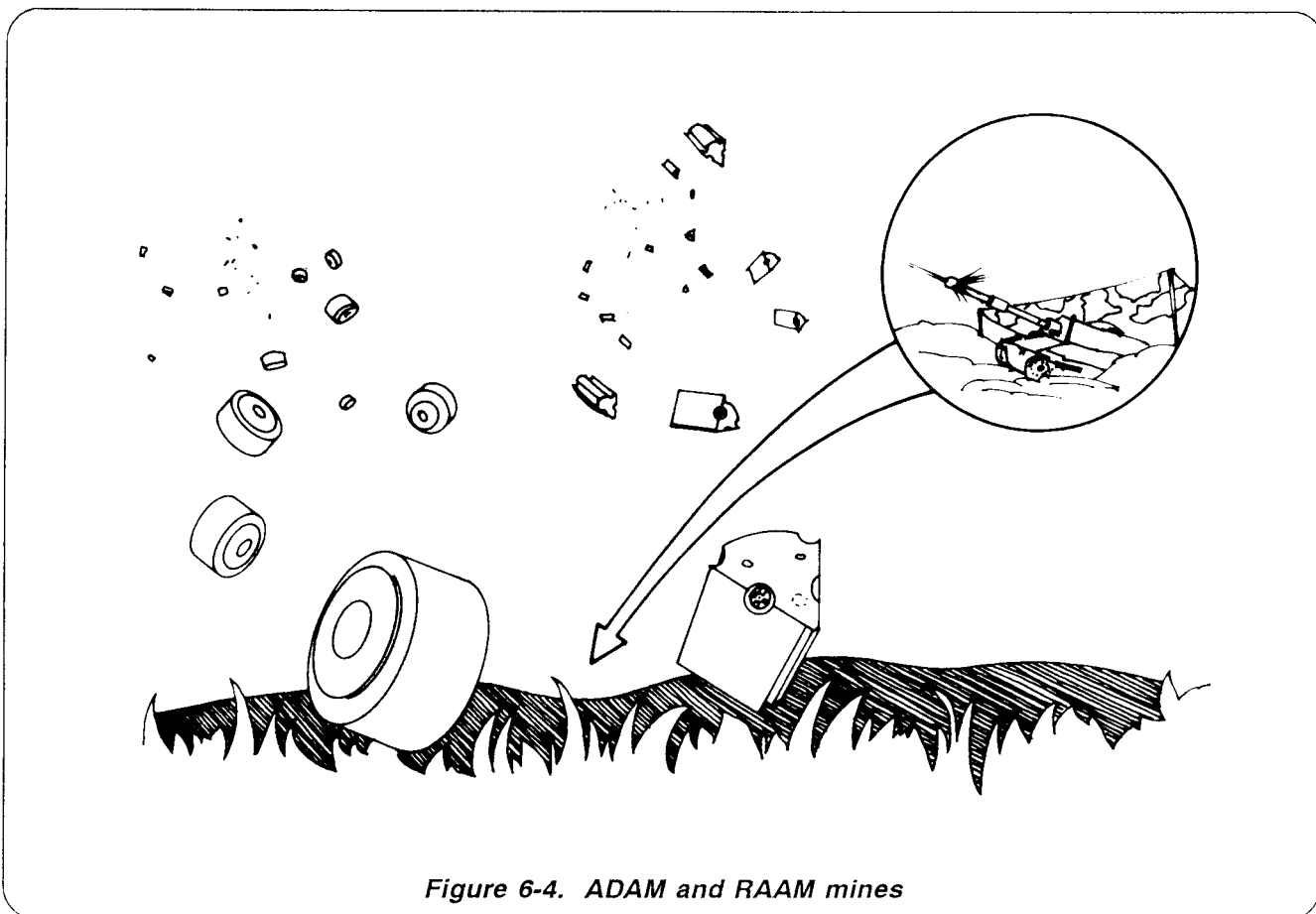

Figure 6-4. ADAM and RAAM mines

The M741 (short duration) and M718 (long duration) RAAMs are artillery-delivered AT mines. Each RAAM artillery round contains nine mines. The M741/M74111 round contains M70 AT mines with a 4-hour self-destruct time; the M718/M718A1 round contains M73 AT mines with a 48-hour self-destruct time. Self-destruct times are preset during the manufacturing process and cannot be changed.

The RAAM mine utilizes an SFF warhead, has a magnetic-influence fuze, weighs 3.8 pounds, and has a small (4.75 inches in diameter by 2.6 inches in height) cylindrical shape. Newer model ADAM and RAAM mines (designated by A1) have a 45-second arming time. Older models have a 2-minute arming time. The newer model RAAM has a built-in feature that defeats magnetic signature-duplicating breaching devices.

### Employment.

ADAM and RAAM systems were designed to provide flexible, rapid-response mining capabilities. These systems provide the maneuver commander with the capability to emplace mines directly on top of, in front of, or behind enemy forces. This is their greatest advantage. Their responsiveness allows the mission to be executed quickly and allows the commander to effectively influence a rapidly changing battlefield. Their major advantage is that they allow the commander to emplace minefields while maintaining maximum stand-off from the target. In short, they do not require committing any force (ground or air) forward to emplace. ADAM and RAAM systems may be used for the following purposes:

In defense, ADAMs and RAAMs may be used to—

- Develop targets for long-range AT weapons.
- Close gaps and lanes in other obstacles.
- Delay or disrupt attacking forces.
- Deny enemy unrestricted use of selected areas.
- Disrupt movement and commitment of second-echelon forces.
- Disrupt and harass enemy command and control, logistics, or staging areas.
- Reinforce existing obstacles.
- Disrupt or delay river crossings.

In offense, ADAMs and RAAMs may be used to—

- Supplement flank reconnaissance and security forces in protecting flanks along AAs.
- Suppress and disrupt enemy security elements once contact has been made.
- Hinder withdrawal of enemy forces.
- Hinder the enemy's ability to reinforce the objective area.

The time and number of rounds required to install effective ADAMs and RAAMs limit their use. Their range is also limited to 17,500 or 17,740 meters depending on whether the M109 or M 198 is used. Many deep-interdiction missions supporting AirLand Battle require a greater distance. Due to the large *footprint* created when the minefield is fired, many mines will be scattered outside the minefield *box* requested. It is therefore necessary to plot the safety zone in order to prevent fratricide. The fire support element (FSE) is responsible for plotting the safety zone. The staff engineer should be familiar with the process and the expected results. He ensures the safety zone is plotted on the tactical command post (TAC CP)/tactical operations center (TOC) operations overlay.

### Emplacement.

ADAM and RAAM mining missions are requested through normal artillery support channels. Although actual numbers vary based on the unit and mission, a representative basic load for an artillery battalion consists of approximately 32 ADAMs and 24 RAAMs (short self-destruct times) rounds per gun tube. The long self-destruct rounds are normally used for preplanned targets and are issued from an ammunition supply point (ASP) on a mission basis.

Once the proper authorization has been received to employ mines, requests for ADAM and RAAM mines are processed in the same way as normal requests for fire support, including targets of opportunity. Exercise prudent judgment with moving targets of opportunity. Allocate enough time for processing the request and completing firing procedures. This ensures the enemy has not moved out of the target area before execution. The use of ADAMs and RAAMs for preplanned fires requires close coordination among the G3/S3, engineer, and FSE sections. Relationships and responsibilities for conducting artillery-delivered scatterable mine missions are outlined in Chapter 7.

There are two critical aspects to emplacing ADAM/RAAM minefields—designing the minefield to achieve the required effect, and ensuring the technical correctness of resourcing and delivering the minefield. The engineer is responsible for deciding the location, size, and type minefield to ensure support of the tactical plan. The FSE is responsible for integrating the delivery of the minefield into the fire support plan based on the tactical situation and the commander's intent and priorities. The FSE is responsible for determining all technical aspects of delivery such as the number of rounds required to achieve the density, range to target, time needed to emplace, and number and location of aim points.

The following discussion provides general guidance on designing the minefield to achieve the effect and determine the safety zone to assess the impact on maneuver. Appendix H of FM 6-20-40 serves as the primary source

for technically resourcing and delivering artillery-delivered minefields.

ADAM and RAAM minefields can be emplaced to achieve disrupt, fix, turn, and block effects based on the principles outlined in Chapter 2. The engineer is responsible for deciding the required location, density, size, composition, and duration of the minefield based on the tactical obstacle plan and obstacle restrictions of the higher unit. The engineer provides this information to the FSE on DA Form 5032-R. Table 6-3 provides guidance on minefield density and size necessary to achieve the right obstacle effect.

The FSE determines all technical aspects of delivering the minefield. The FSE determines the number of rounds required per aim point, the number of aim points, the size of the safety zone, and the time required to emplace mines. There is a wide variety of factors involved in determining the number of rounds, size of the safety zone, and emplacement time. Examples are: the range-to-target, battery-to-minefield angle, high- or low-angle trajectory, and method of firing (observer adjust or meteorological data/velocity error (Met+VE transfer)). It is the responsibility of the FSE to tell the engineer whether the minefield mission is feasible based on the number of rounds available, scheme of indirect fires, and availability of artillery tubes.

The engineer is primarily concerned with two technical aspects of delivery provided by the FSE—the safety zone and the emplacement time. The engineer uses the safety zone and

minefield duration to assess the impact of the minefield on the mobility requirements of the scheme of maneuver. The engineer depicts the safety zone on the obstacle overlay. Also, the engineer uses the safety zone to identify requirements for minefield marking if the unit leaves or turns over the area before the self-destruct time. The engineer and FSE use the emplacement time to synchronize the delivery of the minefield with the tactical plan.

### Gator

The Gator (Figure 6-5, page 6-12) has a longer range than any other available scatterable mine system. It provides a means to rapidly emplace minefields anywhere that can be reached by tactical aircraft. The Gator is produced in two versions. The Air Force CBU-89/B system contains 94 mines (72 ATs and 22 APs) per dispenser; the Navy CBU-78/B system contains 60 mines (45 ATs and 15 APs) per dispenser. The mix for each dispenser is approximately three AT mines to one AP mine.

Mines used with the Gator are the BLU-91/B AT mine and the BLU-92/B AP mine. They are similar to those used with the Volcano. The mines are capable of three field-selectable, self-destruct times (4 hours, 48 hours, and 15 days). Both types of mines are encased in a plastic, square-shaped protective casing designed to aid dispersion and lessen ground impact upon delivery.

Mines are contained inside tactical munitions dispensers (TMDs) attached under the wings of high-performance, fixed-wing aircraft. The

Table 6-3. RAAM/ADAM minefield density and size

| Obstacle effect | Minefield densities |        |        |        | Width (meters) | Depth (meters) |
|-----------------|---------------------|--------|--------|--------|----------------|----------------|
|                 | RAAM                |        | ADAM   |        |                |                |
|                 | Area                | Linear | Area   | Linear |                |                |
| Disrupt         | 0.001               | 0.2    | 0.0005 | 0.1    | 200            | 200            |
| Turn            | 0.002               | 0.8    | 0.001  | 0.4    | 400            | 400            |
| Fix             | 0.002               | 0.4    | 0.0005 | 0.1    | 200            | 200            |
| Block           | 0.004               | 1.6    | 0.002  | 0.8    | 400            | 400            |

Area density - mines per square meters  
 Linear density - mines per meter front

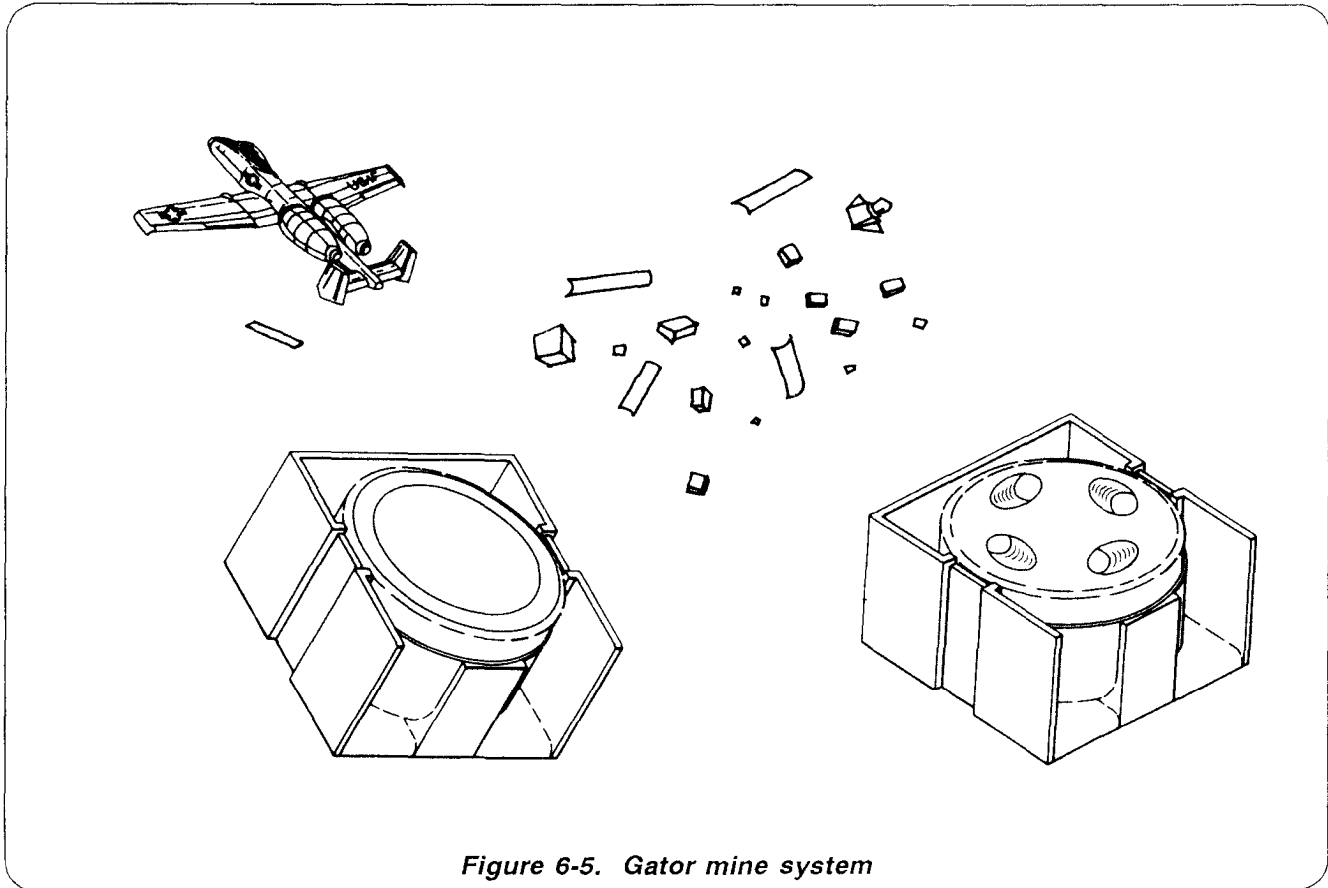

Figure 6-5. Gator mine system

TMD is a new Air Force dispenser designed for common use with future cluster munitions. Gator is compatible with the Air Force A-10, F-4, F-16, F-111, and B-52 aircraft and the Navy A-6, A-7, F-4, FA-18, and AV-8B aircraft. While airborne, the dispenser is released and allowed to fall free. Four linear charges along the edge of the dispenser cut the outer casing, and the mines are aerodynamically dispersed. The maximum delivery speed is 800 knots at altitudes of 250 to 5,000 feet. The area of minefield coverage depends on the number of munitions carried, the aircraft speed and altitude, and the altitude that the fuze functions and opens the dispenser. The average area covered is approximately 200 by 650 meters.

### Employment.

Gator missions are primarily used at long-range with the intent to disrupt, fix, or block enemy troop movements beyond the FLOT.

The placement cannot be precise, because a one-second error in releasing the bomblet causes a significant change in minefield placement. All Gator missions should be preplanned. Gator munitions are well-suited for placing minefields on specific concentrations of forces (artillery, logistic, or command and control) that are out of range of conventional artillery.

While the Gator is capable of providing close combat support, deep interdiction mining is expected to be its primary mission. Normally, Gator minefields are employed in conjunction with other deep indirect fire attacks such as area of interest (AI), battlefield air interdiction (BAI), or joint air attack team (JAAT). However, a Gator minefield may be employed in conjunction with close air support and be covered by close indirect and direct fire systems. Typical Gator mining missions include the following:

- Isolate objectives.
- Counter ADA/artillery fires.
- Deny terrain.
- Disrupt and disorganize support activities.
- Inflict personnel and equipment losses.

The extended range of the Gator system, together with its speed and responsiveness, make it one of the most influential weapon systems on the deep battlefield. The primary limitations of the Gator are the competition for high-performance aircraft to emplace mines and its relative ineffectiveness on units in column. During any conflict, aircraft will be in high demand and will not always be immediately available for a Gator mission when required. Communications may also pose a problem because mission execution is a joint Army-Air Force operation.

The Gator is well-suited to support contingency operations and amphibious landing operations in an immature theater when there is no danger to friendly forces or host nation assets. Gator minefields are one of the light force commander's few durable, long-range antiarmor weapons.

### Emplacement.

As an aircraft-delivered munition, the Gator is a corps asset. The Gator is a BAI mission and as such is controlled by the tactical air control center. Missions are requested 24 hours in advance through fire support channels to the corps FSE. As a mine system, Gator missions must be approved by corps. Corps FSE passes the mission to the theater/army group air headquarters for execution. In support of BAI or close air support (CAS), Gator sorties may be allocated down to battalion level with final control exercised by the battalion air liaison officer (ALO). Immediate Gator missions can also be requested directly from the maneuver unit tactical air control party. The same records and reports applicable to other scatterable mine systems are used with the Gator.

Close cooperation and coordination among the G3/S3, staff engineer, and ALO are required

for planning and executing Gator missions. Responsibilities and guidelines involving Gator missions are discussed in Chapter 7.

As with artillery-delivered minefields, the engineer is primarily responsible for identifying the minefield location, size, duration, and density. Minefield density is varied by changing the orientation of the minefield with respect to the target AA. Figure 6-6, page 6-14, illustrates how minefield orientation is changed to achieve a fix or block effect. Normally, Gator is employed as a fixing obstacle with a frontage of 650 meters. Emplacing a fix obstacle group along a battalion AA (1,500 meters) requires two Gator sorties delivering two minefields. Each Gator minefield would have a frontage of 650 meters and a depth of 200 meters. The minefields would be delivered at different locations so that the group covers the entire AA and affects the entire enemy battalion.

### M128 GEMSS

The GEMSS is a trailer-mounted system (Figure 6-7, page 6-14) that is towed by a variety of wheeled and tracked vehicles. It is usually towed by an M113, a 5-ton dump truck, or an M9 armored combat earthmover (ACE). The dispenser consists of two magazines; each magazine holds 400 mines. Mines are fed from magazines into the ejector that propels them 30 meters from the centerline of travel. The dispenser is controlled by the operator via a detachable, remote-control panel that allows selection of mine pattern, density, and self-destruct time. One of six pattern positions may be selected from the panel, allowing the operator to lay 26-, 34-, or 60-meter-wide mine strips (Figure 6-8, page 6-15). The sixth position (position J) allows the operator to lay mines in special patterns.

There are five density selections on the control panel— 0.001, 0.005, 0.007, 0.010, and 0.025 mine per square meter. The system has an effective emplacement speed of 5 to 8 mph that allows the entire 800 mines to be dispensed in about 15 minutes. The operator can also select a normal self-destruct time of 5 days or an extended self-destruct time of 15 days.

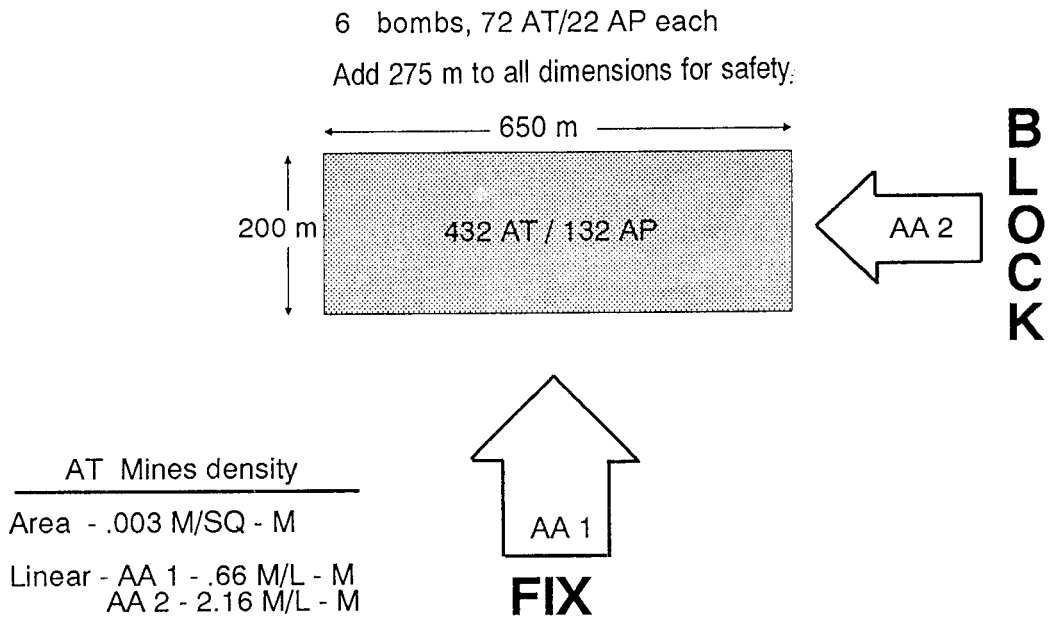

Figure 6-6. Scatterable mine employment of a Gator minefield

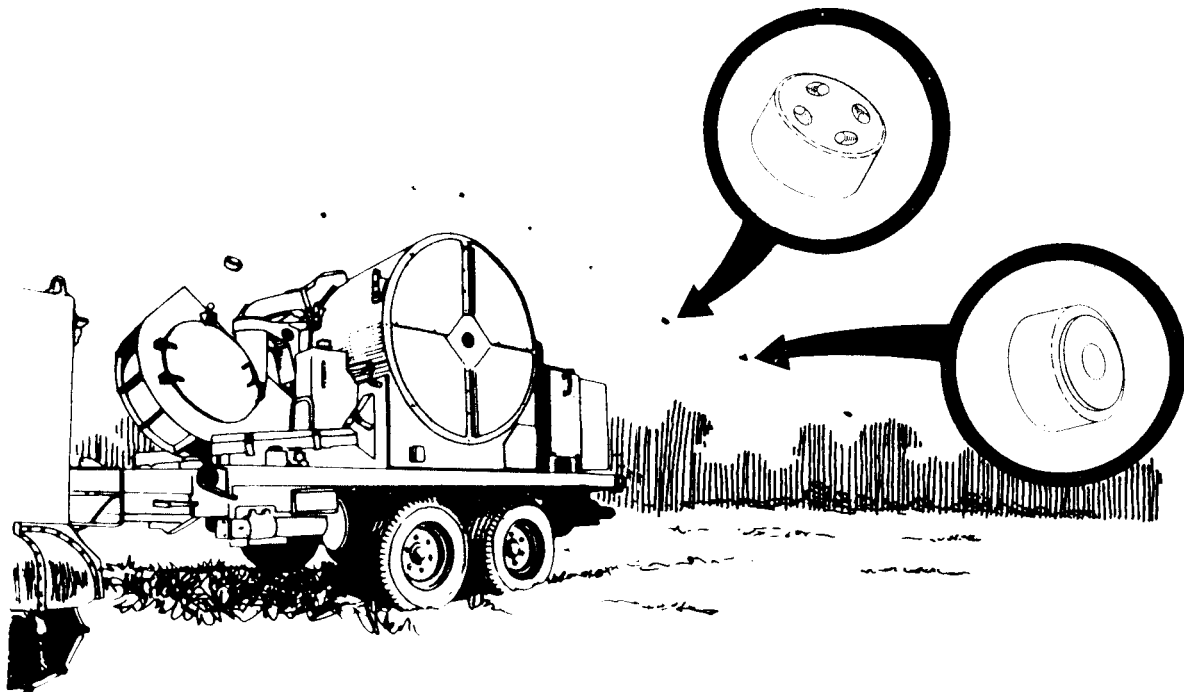

Figure 6-7. M128 Ground-Emplaced Mine Scattering System (GEMSS)

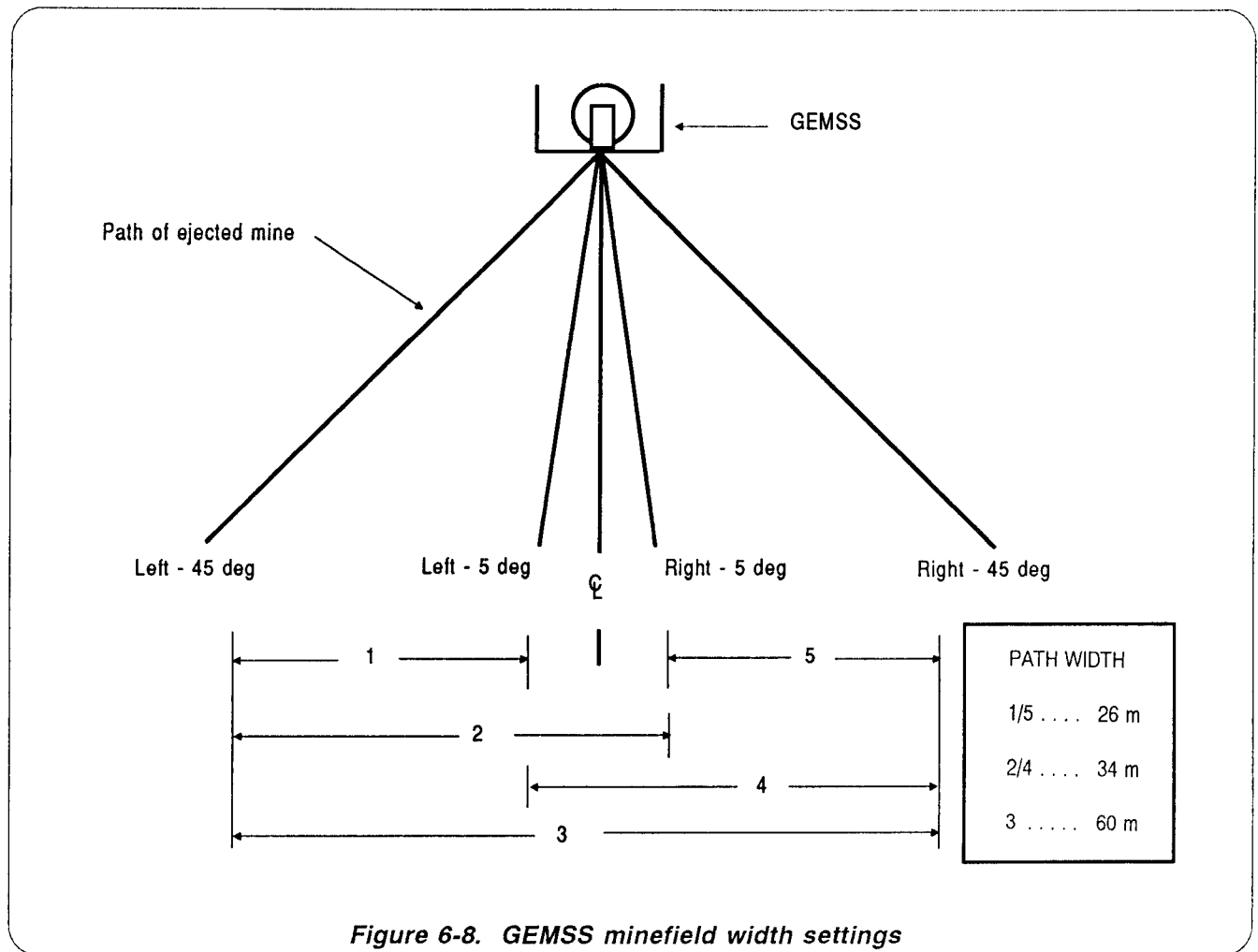

Figure 6-8. GEMSS minefield width settings

GEMSS M75 AT and M74 AP have a unique arming feature that requires spinning at a high velocity before the mines are armed. As the dispenser ejects the mines, they are spun at more than 2,500 revolutions per minute (rpm). This spinning action and a magnetic arming signal initiate arming sequences, and the mines are armed after a 45-minute delay period. Mines come in sleeves of five mines each; there are eight sleeves per shipping container.

**Employment.**

The GEMSS system was designed primarily to provide rapid emplacement of large minefields in areas controlled by friendly forces. It can be used to emplace tactical or protective minefields; however, it is normally employed only for tactical minefields. Key advantages of

the GEMSS are the 800-mine capacity of the dispenser and the speed of emplacement. The GEMSS is capable of rapidly emplacing large-scale tactical minefields while making minimal stops for loading.

Major limitations of the system include the vulnerability of operating personnel to small caliber fire, support assets required to conduct the mission, and the arming initiation sequence. The GEMSS is too vulnerable to be employed along the FLOT. It is used as an obstacle reserve and employed when the enemy reaches a decision point that indicates future movement. Obstacles can then be emplaced on avenues the enemy is using, leaving other avenues open for friendly movement. This type employment requires at least six hours notice before minefield completion to allow for movement, emplacing the minefield, and arming

time. This time can be reduced if minefields are preplanned and the GEMSS is prelocated at the most likely minefield location. Possible employment of GEMSS includes—

- Tactical minefields.
- Situational minefields to protect the flanks of an attacking or advancing force.
- Reseeding breached minefields or closing gaps left in friendly minefields.
- Reinforcing existing minefields or obstacles.
- Mining potential drop zones (DZs) or landing zones (LZs).

### Emplacement.

GEMSS missions are tasked to engineer units in the same manner as conventional minefield missions. The type minefield to be emplaced and the self-destruct period determine the authorization required for employment. Once a unit has authorization to emplace a GEMSS, the G3/S3 and the staff engineer plan the minefield. As a minimum, the following items should be addressed in the plan:

- Location and proposed frontage of the minefield.
- Self-destruct time setting.
- AT to AP mine ratio.
- Number and width of strips.
- Mine density.

Although specific mission requirements vary depending on the tactical situation, several planning guides have been developed. Minefield density and width setting are based on METT-T considerations. The width of each strip is influenced by considerations such as mining a road or just the road shoulders. The system is extremely flexible. Table 6-4 provides guidance on combining density setting, strip width, and number of strips to achieve disrupt, fix, turn, and block minefields.

For example, a turn minefield could be emplaced using one 60-meter strip with an area density setting of .025 or by using three 34-meter strips with a .01 area density setting. Other combinations are possible using the chart and are based on METT-T.

Figure 6-9 provides another technique for employing the GEMSS to emplace standard disrupt, fix, turn and block minefields. This technique uses standard GEMSS minefield packages, reduces the decisions the crew must make on minefield design, and standardizes emplacement drills. These standard packages are based on using only one of two density settings; emplacing one or two strips; and using only AT mines in disrupt, fix, and turn minefields. AP mines are mixed during loading using a 5 AT:1 AP mine mix for block minefields only. Minefield depth and frontage are varied for each type minefield per the principles outlined in Chapter 2. Figure 6-9 illustrates the strip layout for each type minefield. One load of GEMSS is capable of seven disrupt, five fix, one turn, or one block minefield.

GEMSS mines are dispensed approximately 30 meters, at a velocity of approximately 50 feet per second (15 meters per second). This presents a hazard to personnel in the rear of or in line with the dispenser. Personnel marking the location of mines must stay a minimum of 300 feet (92 meters) behind the vehicle. All personnel in the area must be cautioned concerning this hazardous area. If a mining mission requires dispensing mines over hilly terrain, mining should be accomplished while traversing across the top of the hill or while going uphill. Mining missions should not be conducted when descending a steep hill because mines may roll to the base of the hill. When mining on hilly terrain, the danger area should be expanded, to include the area from the top to the base of the hill.

During dispensing operations, adhere to warnings found in the operator's manual and those indicated on the dispenser. These precautions address requirements for hearing protection for all personnel within 25 feet of the dispenser and the host vehicle. Host vehicles determine the need for hearing protection.



Table 6-4. GEMSS emplacement data

**Lethality and obstacle function**

**Density**                      Linear density for: 1 strip/2 strips/3 strips

|             |                       |                         |                          |
|-------------|-----------------------|-------------------------|--------------------------|
| .001 m/sq m | .06/.12/.18<br>D/D/D  | .034/.068/.102<br>D/D/D | .026/.052/.078<br>D/D/D/ |
| .005 m/sq m | .3/.6/.9<br>D/F/F     | .17/.34/.51<br>D/D/F    | .13/.26/.39<br>D/D/D     |
| .007 m/sq m | .42/.84/1.26<br>D/F/T | .24/.48/.71<br>D/D/F    | .18/.36/.55<br>D/D/D     |
| .01 m/sq m  | .6/1.2/1.8<br>F/T/B   | .34/.68/1.02<br>D/F/T   | .26/.52/.78<br>D/F/F     |
| .025 m/sq m | 1.5/3.0/4.5<br>T/B/B  | .85/1.7/2.55<br>F/T/B   | .65/1.3/1.95<br>T/T/B    |

60 M                      34 M                      26 M

D - disrupt    F - fix    T - turn    B - block

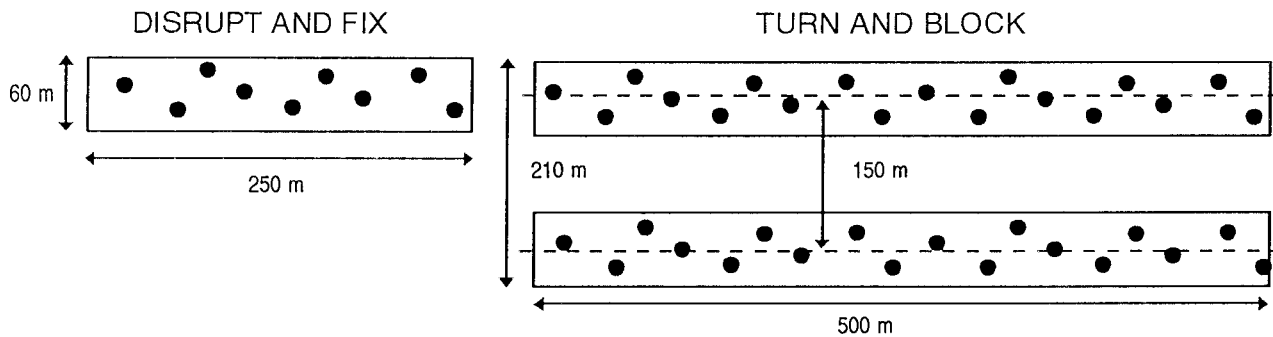

| Type minefield | Path setting | Area density setting | Effective linear density | Number of strips | Depth | Frontage | Number AT mines M75 | Number AP mines M74 | Number minefield in one load |
|----------------|--------------|----------------------|--------------------------|------------------|-------|----------|---------------------|---------------------|------------------------------|
| Disrupt        | 60 m         | 0.007                | 0.42                     | 1                | 60    | 250      | 105                 | 0                   | 7                            |
| Fix            | 60 m         | 0.01                 | 0.6                      | 1                | 60    | 250      | 150                 | 0                   | 5                            |
| Turn           | 60 m         | 0.01                 | 1.2                      | 2                | 210   | 500      | 600                 | 0                   | 1                            |
| Block          | 60 m         | 0.01                 | 1.2                      | 2                | 210   | 500      | 500                 | 100*                | 1                            |

\*NOTE: Requires loading mix of 5-M75 AT mines : 1-M74

Figure 6-9. Standard GEMSS minefield patterns, settings, and resources

### M138 Flipper

The Flipper is a manual, auxiliary dispenser designed to emplace M74 AP and M75 AT mines designed for the GEMSS (Figure 6-10). The Flipper is a simple dispensing system and uses little automation to load and dispense mines. In short, mines are loaded by hand into the

feeder chute. The operator determines the pattern by manually pivoting the dispenser across a 180-degree arc. Mines are dispensed in a 35-meter arc from the host vehicle. The Flipper provides the commander with great flexibility since it can be mounted on M113 personnel carriers, M548 cargo carriers, 2-ton cargo and dump trucks, or 5-ton cargo and

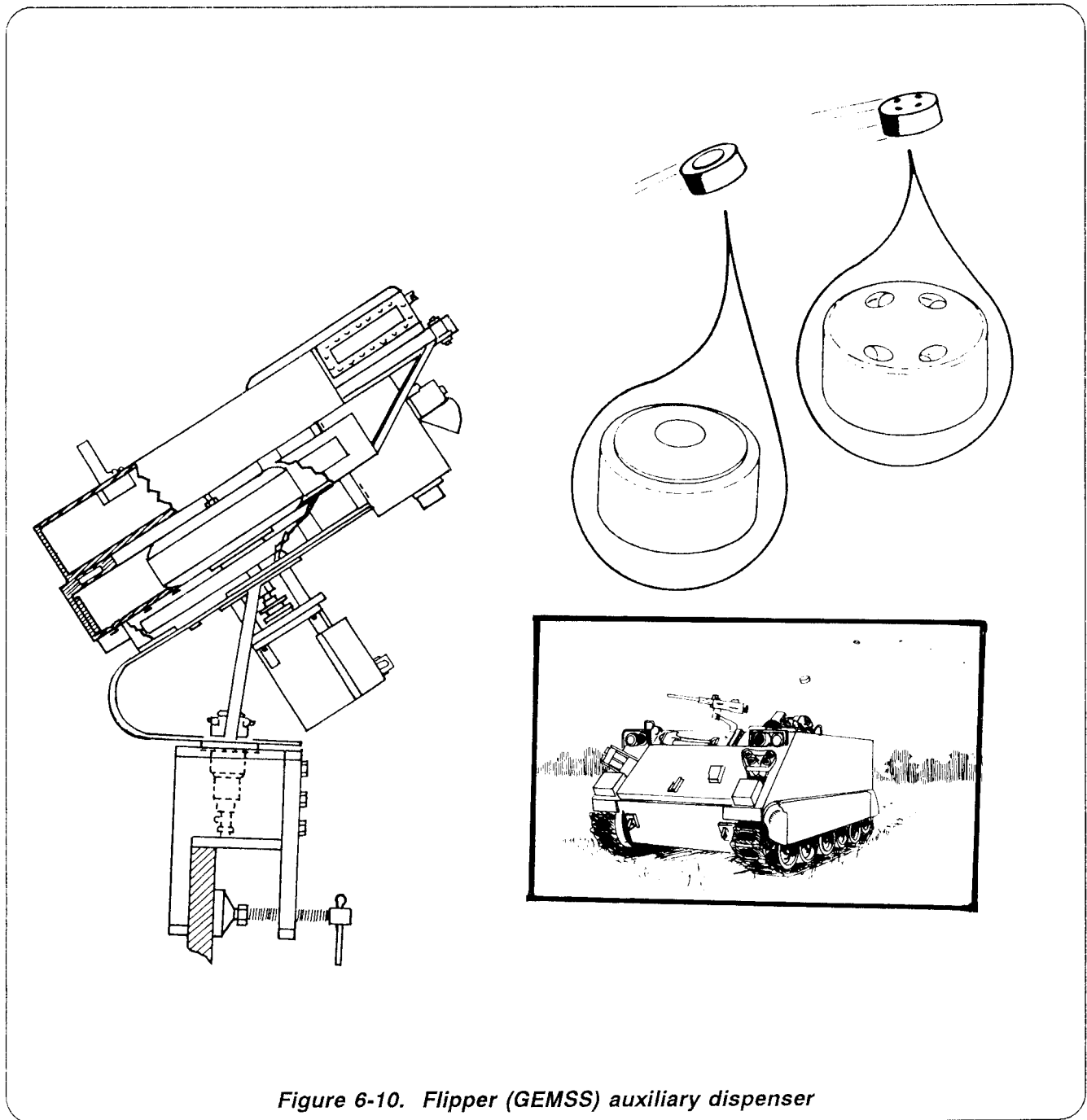

Figure 6-10. Flipper (GEMSS) auxiliary dispenser

dump trucks with no modification. The Flipper weighs approximately 130 pounds.

The Flipper uses the electrical power system of the host vehicle and launches the standard GEMSS mine 35 meters from the vehicle. It performs functions similar to the GEMSS dispenser (starts the arming cycle, sets the self-destruct time, and deploys the mine), and is the only alternative means of employing GEMSS mines. It can dispense six mines per minute. Mine deployment requires only two people—the mine loader and the operator. The Flipper can be used to augment the GEMSS since it emplaces the same mines, or the Flipper can be employed by itself.

### Employment.

Employment considerations for the Flipper are essentially the same as those for the GEMSS. The major limitations of the Flipper are that it requires the crew to be exposed during operation and it cannot dispense mines on the move. However, when mounted on a tracked vehicle, the Flipper gives the commander the ground mine-dispensing capability that can keep up with maneuver forces during movement, and it can emplace a minefield quickly in response to a threat. An additional advantage is the system's versatility when emplacing mines. It can be used to emplace standard tactical minefields, small point minefields, or protective minefields relatively close to friendly positions. Manually aiming the dispenser allows engineers to emplace scatterable mines with great accuracy on a point target or in restrictive terrain.

### Emplacement.

To minimize hazard risks to the Flipper operator, *stop-and-dispense* laying procedures should be conducted. However, if it is necessary to dispense while the host vehicle is in motion (roll and dispense), speed restrictions on the host vehicle must be applied. Personnel should not operate the Flipper dispenser when the prime vehicle speed

exceeds 8 kilometers per hour (kph) (5 mph) on highways or 2.8 kph (1.76 mph) off the road. Since it is very difficult to maintain a speed under 2 mph, the stop-and-dispense laying procedure is recommended. Flipper minefield density and composition can be varied by the operator. The density is varied by the number of mines dispensed at each stopping point. The mix of mines in the minefield is determined by the number of AT and AP mines dispensed by the operator at a given stopping point.

When emplacing a standard minefield intended to disrupt, fix, turn, or block with the Flipper, the crew uses a set stop-and-dispense procedure. During site layout, dispensing markers are placed every 35 meters along a centerline. These markers are offset from the centerline half the width of the vehicle to the left (relative to the direction of emplacement). This allows the vehicle driver to guide on the markers during movement and allows the vehicle to remain on the centerline.

When the driver reaches a dispense marker, he stops the vehicle. The operator then traverses the dispenser to the zero-degree position (at right angle to direction of emplacement toward the enemy) as shown in Figure 6-11, page 6-20. This is the number 1 mine position. The operator dispenses mines in the order shown, traversing the dispenser in a 180-degree arc from the enemy side to the friendly side. The target angles shown are only a guide to achieve optimal spacing between mines and uniform linear density. All angles are relative to the number 1 mine at zero degrees. Crews may want to fabricate and mount an *aiming circle* to make dispensing more accurate. As a general guide, the operator should traverse between 15 and 20 degrees between mines. For all standard minefields, the operator dispenses 10 M75 AT mines (two sleeves) at each dispensing point. For blocking minefields, the operator dispenses five M74 AP mines (one sleeve) in addition to the AT mines.

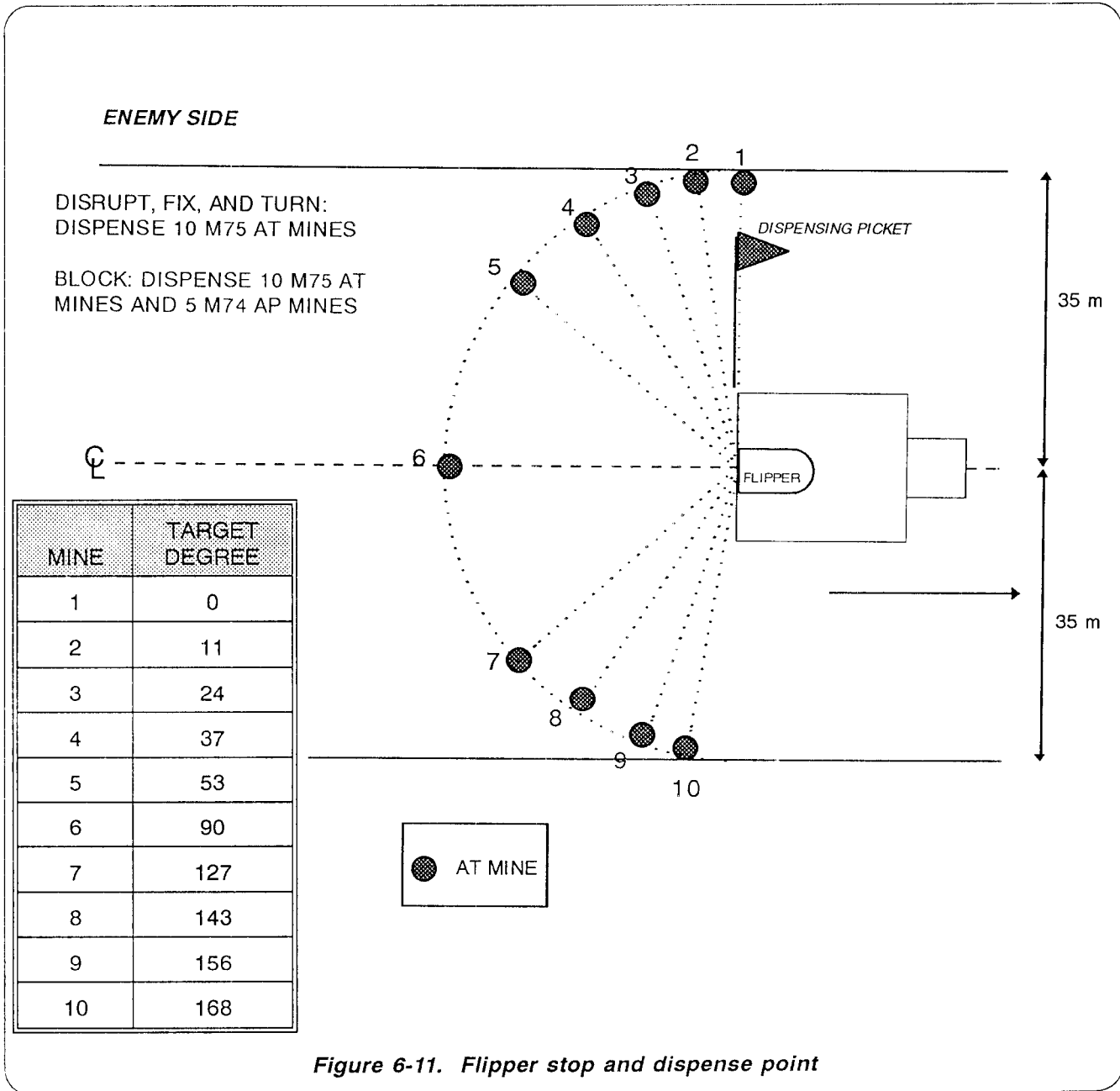
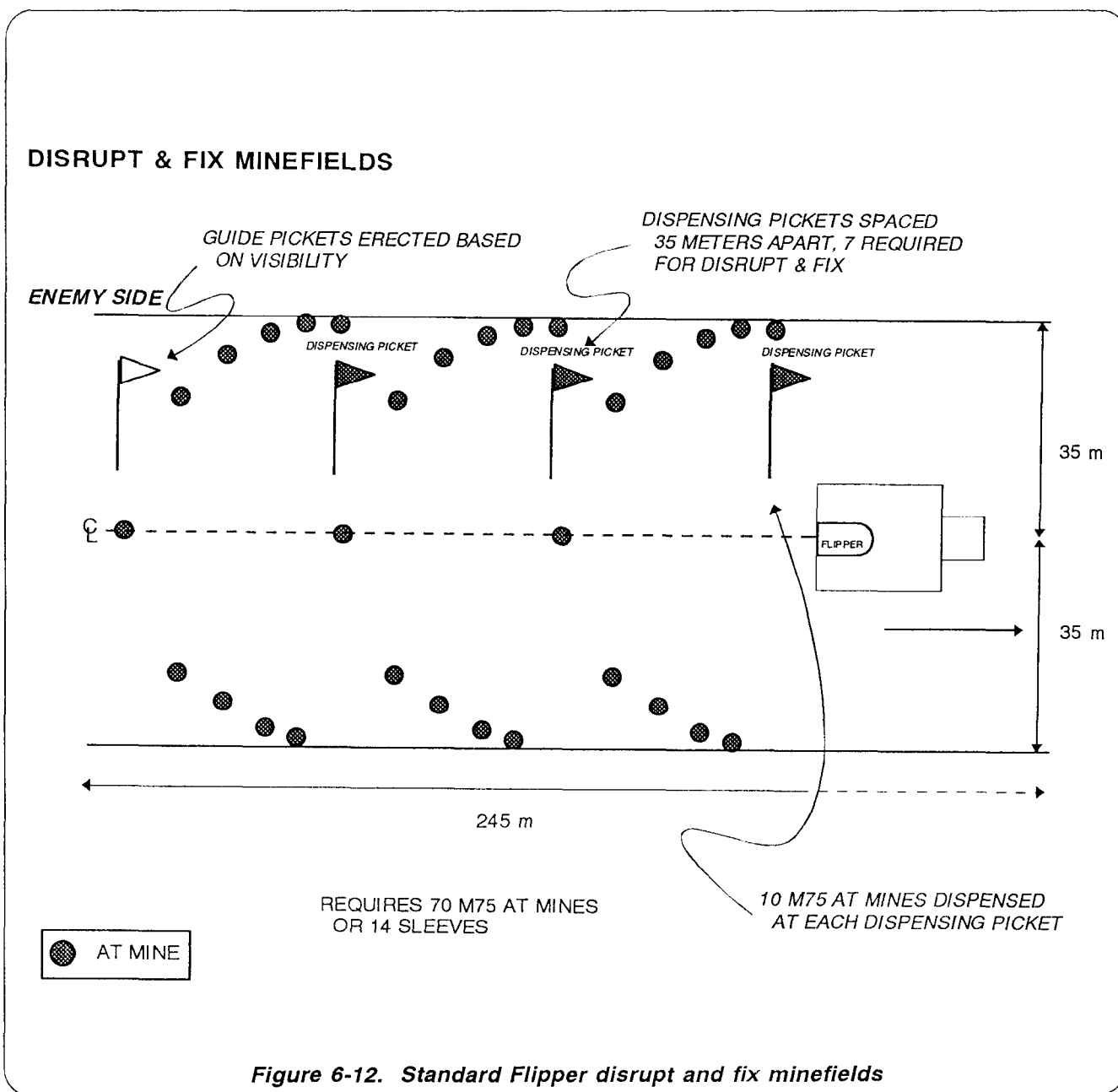

Figure 6-12 illustrates the total pattern for a minefield intended to disrupt or fix. These minefields have a frontage of 245 meters and a total depth of 70 meters. Emplacing fix and disrupt minefields with the Flipper requires

four dispensing points; the first one is 35 meters from the centerline start point. Disrupt and fix minefields require 70 M75 AT mines (14 sleeves).



★ Figure 6-13, page 6-22, illustrates the standard Flipper minefield intended to turn and block. Turn and block minefields require two centerlines 170 meters apart. The minefield frontage is 490 meters and requires 14 dispensing points on each centerline. The total minefield depth is 240 meters. Both turn and block minefields require 280 M75 AT mines (56 sleeves). Block minefields require 140 M74 AP

mines (28 sleeves) in addition to AT mines. Optimally, two Flipper dispensers are used to emplace turn and block minefields so that both strips are emplaced simultaneously. However, one Flipper can emplace both strips, one at a time. Table 6-5 summarizes the site layout and mine requirements for each type Flipper minefield.

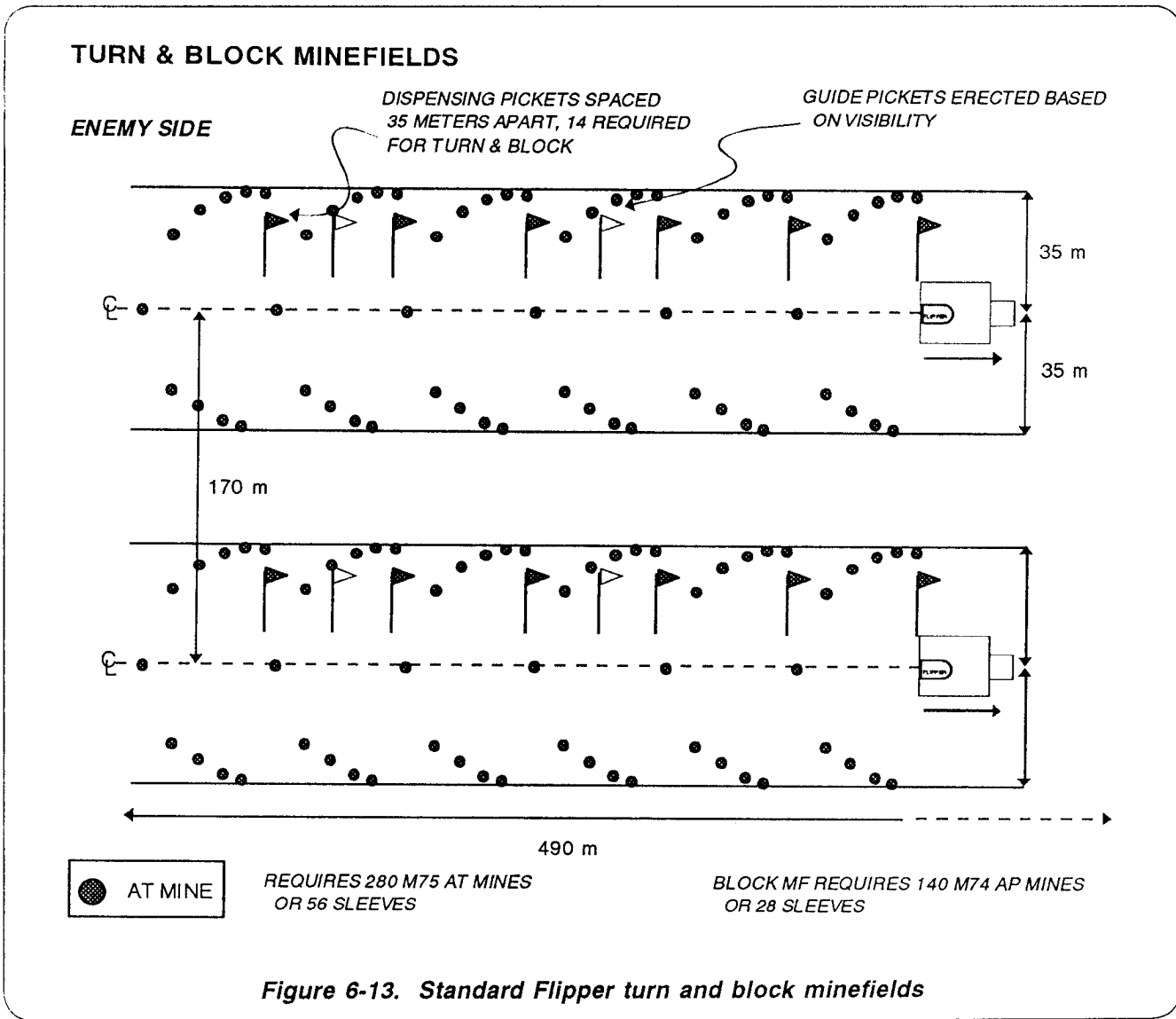

Table 6-5. Flipper minefield data

| Type minefield | Depth (meters) | Front (meters) | Number of strips | Dispensing points per strip | Number M75s per dispensing point | Number M74s per dispensing point | Total number M75 AT mines | Total number M74 AP mines |
|----------------|----------------|----------------|------------------|-----------------------------|----------------------------------|----------------------------------|---------------------------|---------------------------|
| Disrupt        | 70             | 245            | 1                | 7                           | 10 (2 sleeves)                   | 0                                | 70 (14 sleeves)           | 0                         |
| Flx            | 70             | 245            | 1                | 7                           | 10 (2 sleeves)                   | 0                                | 70 (14 sleeves)           | 0                         |
| Turn           | 240            | 490            | 2                | 14                          | 10 (2 sleeves)                   | 0                                | 280 (56 sleeves)          | 0                         |
| Block          | 240            | 490            | 2                | 14                          | 10 (2 sleeves)                   | 5 (1 sleeve)                     | 280 (56 sleeves)          | 140 (28 sleeves)          |

## Volcano

- ★ The multiple delivery mine system (Volcano) (Figure 6-14) is intended to replace the M56 helicopter-delivered mine system, the GEMSS, and the Flipper. It provides a single mine-delivery system capable of being dispensed from the air or the ground. The Volcano can be mounted on a 5-ton vehicle, an M548 tracked cargo carrier, or a UH-60A Blackhawk helicopter. This system uses modified Gator mines and consists of three components (Figure 6-15)—M87 mine canister, the M139 dispenser, and the vehicle-specific mounting hardware (aircraft also require a jettison kit). The Volcano uses the M87 mine canister. The mine canister is prepackaged with five AT mines, one AP mine, and a propulsion device inside a tube housing. The mixture of mines is fixed and cannot be altered in the field. Mines are electrically connected with a web

that also functions as a lateral dispersion device as the mines exit the canister. Spring fingers mounted on each mine prevent mines from coming to rest on their edge. All canisters are capable of dispensing mines with 4-hour, 48-hour, or 15-day self-destruct times. These times are field selectable prior to dispensing and do not require a change or modification in the base M87 canister. The Armament Research Development Center (ARDEC) is redesigning the current Volcano mine to add dual magnetic influence fuzes and to remove the bore-rider timer safe separation device. The bore-rider timer is being replaced with an internal crystal oscillator. The delay arm times have been extended from 2 minutes (both AP and AT) to 2 minutes 30 seconds for the AT mine and 4 minutes for the AP mine. These mines will be in the M87A1 canister.

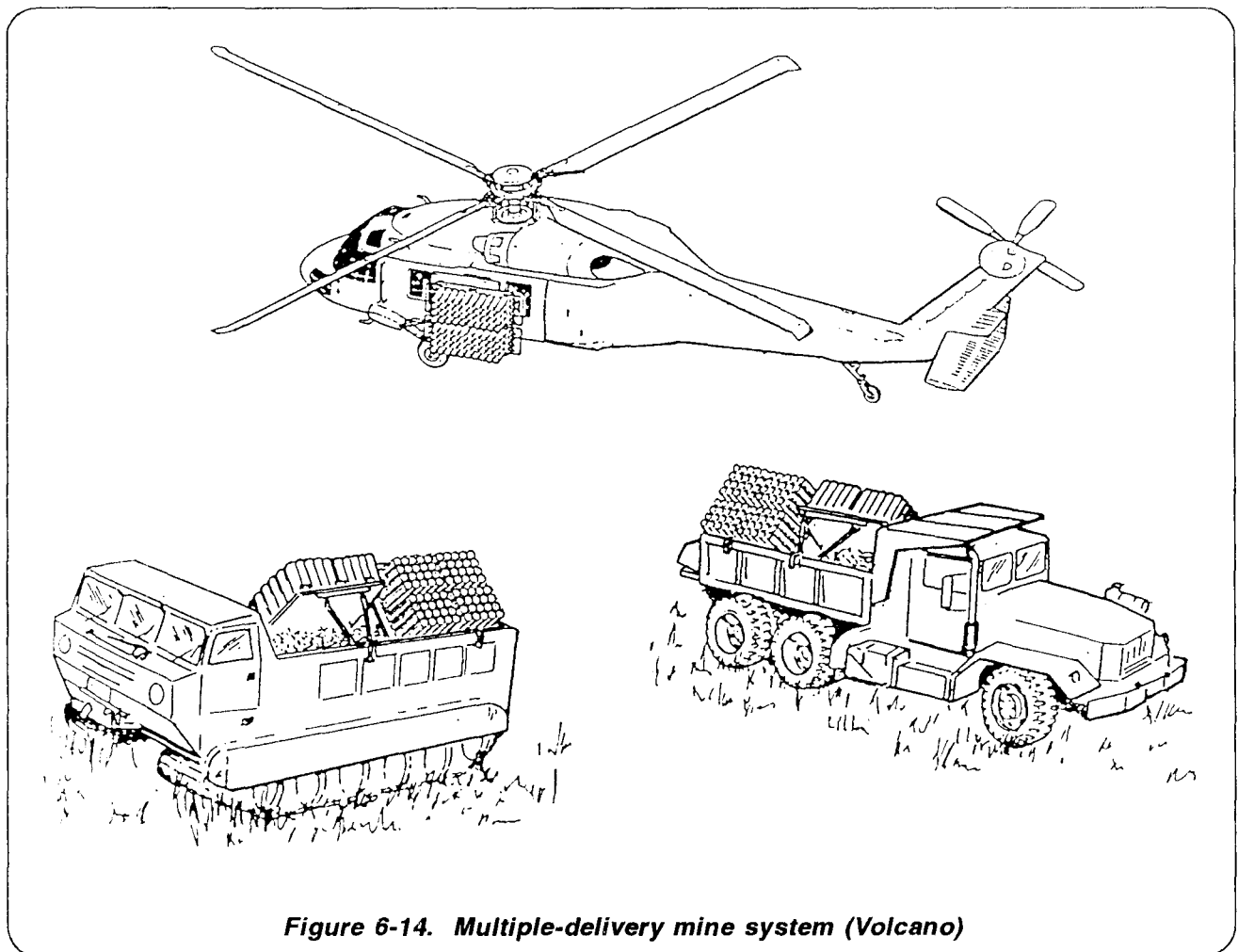

Figure 6-14. Multiple-delivery mine system (Volcano)

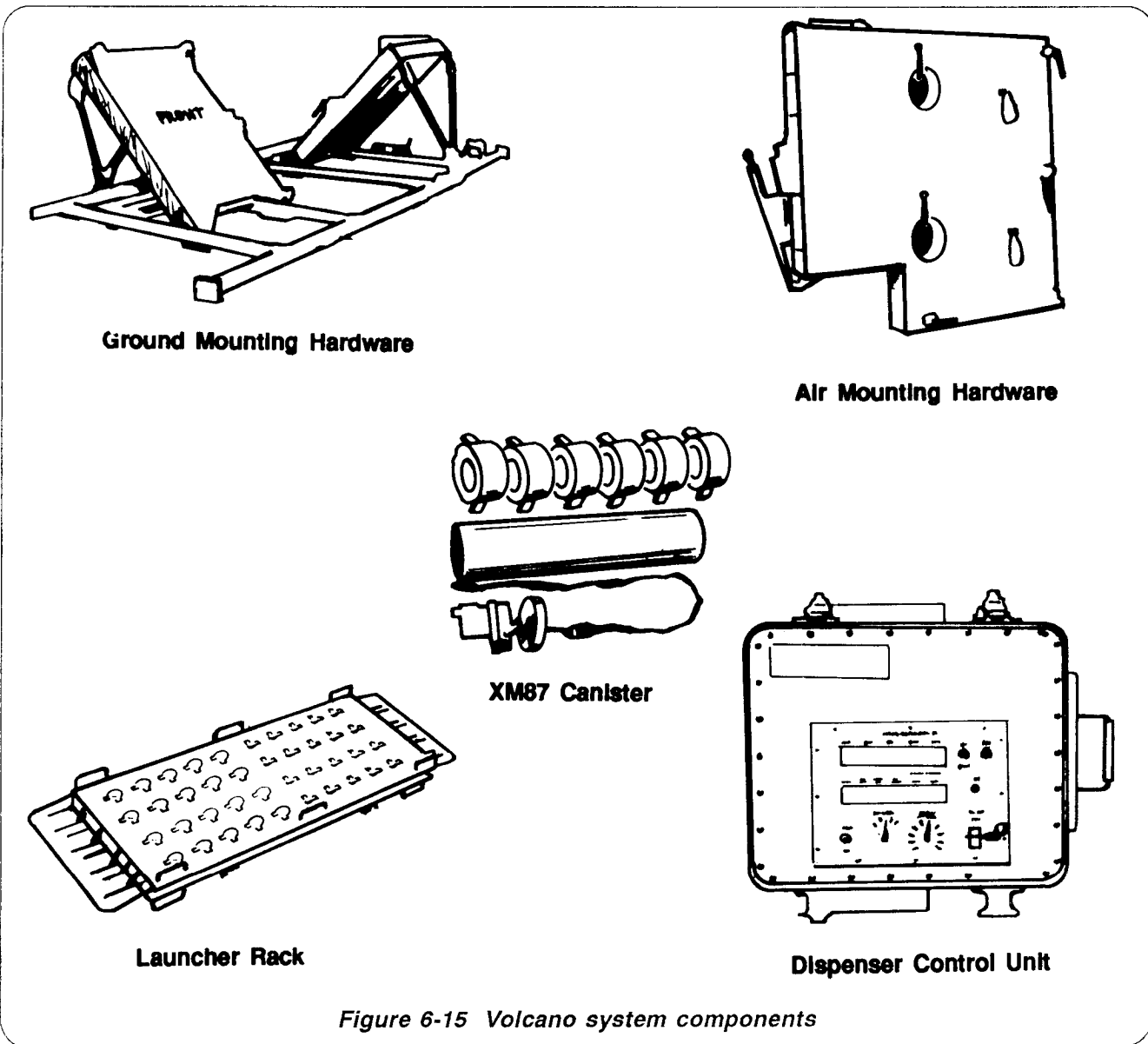

Figure 6-15 Volcano system components

The dispenser consists of an electronic dispenser control unit (DCU) and four launcher racks. Up to four racks can be mounted on a vehicle. Each rack holds 40 M87 mine canisters. The rack provides structural strength and mechanical support required for launch and provides electrical interface between mine canisters and the DCU. Mounting hardware secures racks to the vehicle or aircraft. Mounting hardware for the UH-60A Blackhawk includes a jettison subassembly to propel the Volcano racks and canisters away

from the aircraft in the event of an emergency.

The operator uses the DCU to electrically control the dispensing operation from within the carrier vehicle. The DCU provides controls for the arming sequence and the delivery speed selection. It also sets mine self-destruct times. The DCU allows the operator to start and stop mine dispensing at any time. A counter on the DCU indicates the number of canisters remaining on each side of the carrier.



Mines are dispensed from their canisters by an explosive propelling charge. For ground vehicles, mines are dispensed 25 to 60 meters from the vehicle at ground speeds of 5 to 55 mph. For aircraft, mines are dispensed 35 to 70 meters from the line of flight. The aircraft flies at a minimum altitude of 5 feet, at speeds of 20 to 120 knots. It can deliver up to 960 mines (160 canisters) per sortie. The Volcano uses the host vehicle as a power source. (Attaching the system to the vehicle does not significantly degrade its mobility.) The system has three field-selectable, self-destruct times (4 hours, 48 hours, and 15 days). Except for the mounting hardware, there is total system commonality between air and ground Volcano systems.

### Employment.

The primary mission of the Volcano is to provide US forces with the capability to rapidly emplace large minefields under varied conditions. The Volcano can be rapidly attached to aerial or ground vehicles. It is used to emplace tactical minefields; reinforce existing obstacles; close lanes, gaps, and defiles; protect flanks; and deny enemy air defense sites. Volcano minefields are ideal for flank protection of advancing forces and for operating in concert with air/ground cavalry units on flank guard or screen missions.

The air-dispensed Volcano is the fastest method of emplacing large tactical minefields. When employed by combat aviation elements in support of maneuver units, close coordination between aviation and ground units assures Volcano-dispensed mines are emplaced accurately and quickly. Although placement is not as precise as it is with ground-emplaced systems, air Volcano minefields can be placed accurately enough to avoid the danger inherent in artillery or jet aircraft-delivered minefields. Air Volcano minefields can be emplaced in both friendly and enemy territories. They should not be planned in areas of enemy observation and fire because the helicopter is extremely vulnerable while flying at the steady altitude, speed, and path required to emplace the minefield. The air Volcano system is the best form of an obstacle reserve because a minefield can be emplaced within minutes.

Like the GEMSS, the ground Volcano is designed to emplace large minefields in depth. The ground Volcano is normally employed by combat engineer units. The primary use of mounted dispensers is to emplace tactical minefields oriented on enemy forces in support of maneuver operations and friendly AT fires. The system is vulnerable to direct and indirect fires, so it must be protected when close to the FLOT. It is an ideal obstacle reserve, employed when the enemy reaches a decision point that indicates future movement. Obstacles can then be emplaced on avenues the enemy is using, leaving other avenues open for friendly movement. The Volcano is more mobile than the GEMSS. It is mounted directly on the prime mover and weighs 4 1/2 tons less (loaded) than the GEMSS.

### Emplacement.

The principles of Volcano emplacement are the same as those for air or ground delivery systems. This section outlines the use of the Volcano system to emplace minefields intended to disrupt, fix, turn, and block. Both the ground and air Volcano systems are capable of emplacing nonstandard minefields. However, using the emplacement norms below streamlines identifying resource requirements and emplacement drills.

- ★ The Volcano system emplaces a minefield with an average AT linear density of 0.72 mine/meter and AP density of 0.14 mine/meter. These densities may vary slightly since some mines will fail the arming sequence and self-destruct 2 to 4 minutes after dispensing. Additionally, some mines may not orient correctly, will not deliver their full mine effect, and will not produce a K-Kill, further reducing the effective density. The probability of failing the arming sequence and disorienting is relatively small and does not appreciably degrade the minefield's lethality. For tracked vehicles, the AT density yields more than 80 percent probability of encounter. Volcano AT mines do not have antisturbance devices but are highly sensitive to any movement once they are armed. Any attempt to remove the mines will likely result in detonation.

The basic site layout is the same for all types of Volcano minefields whether delivered by

ground or air. Site layout is extremely important. Wherever the situation allows (planned targets within the main battle area (MBA) of a defensive operation), the limits of air and ground Volcano minefields are marked before emplacement. When the situation does not allow (offensive operations or situational obstacles), the minefield is not premarked but is marked before the unit leaves the area or turns over the area to an adjacent unit if the mines have not self-destructed. Minefield marking must include the safety zone, which is 100 meters from the start and end points and 100 meters to the left or right of the centerline. The start and end points of the strip centerline are marked based on minefield frontage and number of strips. For ground-

emplaced Volcano, guide markers are emplaced along the path of the centerline but offset left to allow the host vehicle to remain on the centerline. The number of guide markers depends on terrain and visibility. Guide markers are not required for air-delivered Volcano since the pilot will use the start and end point markers of the centerline as reference points. Additionally, minefield marking must leave a gap for vehicle entrance and exit of each centerline when using a ground delivery system.

Figure 6-16 illustrates the emplacement pattern for standard disrupt and fix minefields using the ground or air Volcano. Disrupt and fix minefields use only one centerline to give

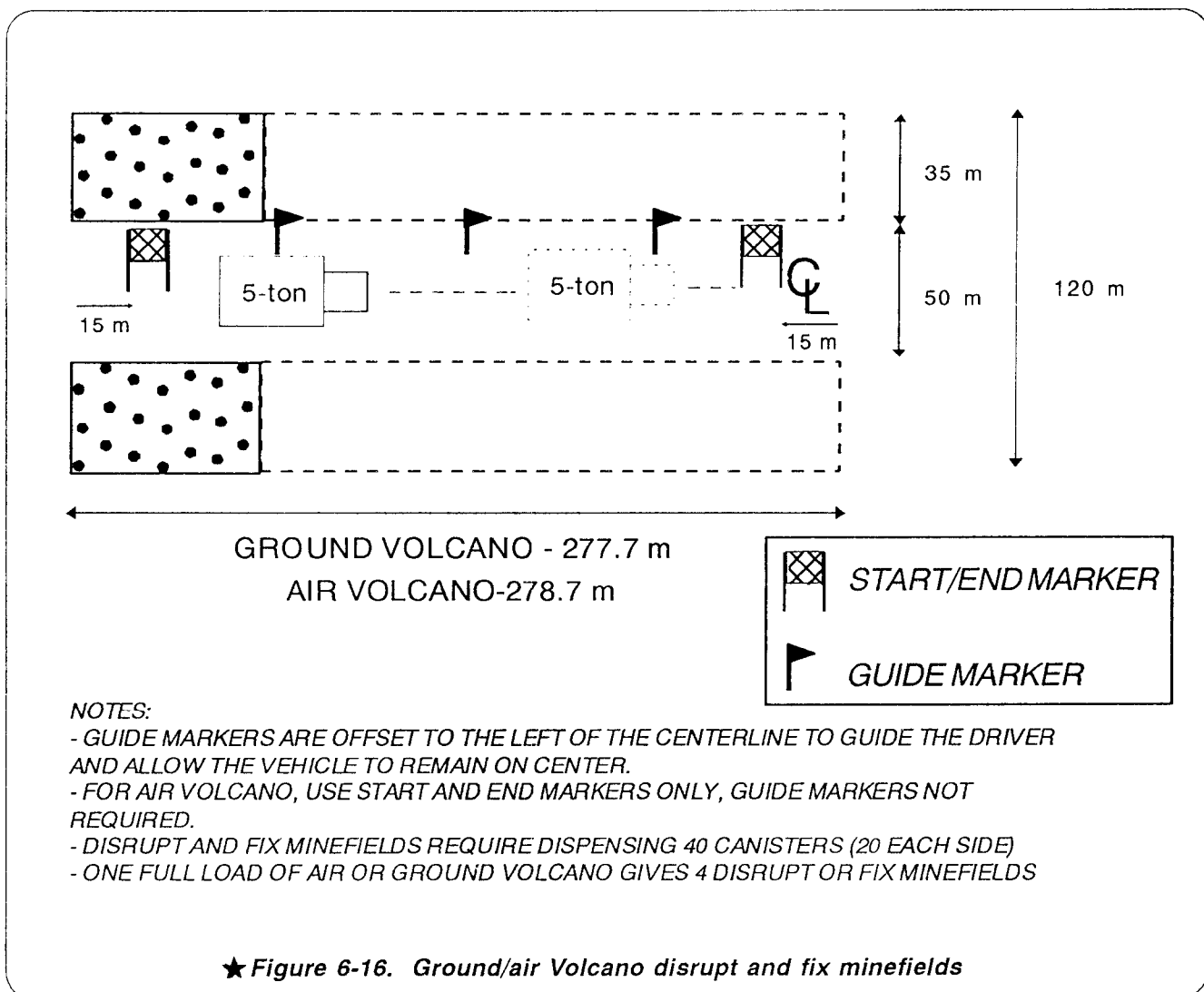

★ a minefield depth of 120 meters (140 meters for air), not including the safety zone. The strip centerline is 277 meters long (278 meters for air). The host vehicle moves toward the start point, achieving and maintaining the ground or air speed selected on the dispensing control unit (DCU). The operator depresses the launch switch on the DCU as the vehicle passes the start point marker and stops as the vehicle passes the end marker. The operator dispenses 40 canisters (20 on each side). For ground emplacement, the vehicle moves out of the minefield, marks the exit, and waits a minimum of four minutes before approaching the minefield. This delay allows faulty mines to self-destruct.

★ Turn and block minefields are emplaced using the same basic procedures as disrupt and fix minefields. However, turn and block minefield use two strip centerlines along a frontage of 555 meters (557 for air) (Figure 6-17). During site layout, centerlines are separated by 320 meters (minimum) for both ground and air delivery. This gives a total minefield depth of 440 meters (460 meters for air). The operator dispenses 80 canisters—40 canisters on each side of each centerline. Both turn and block minefields, therefore, require a total Volcano load of 160 canisters. Wherever possible, two ground Volcanos are employed simul-

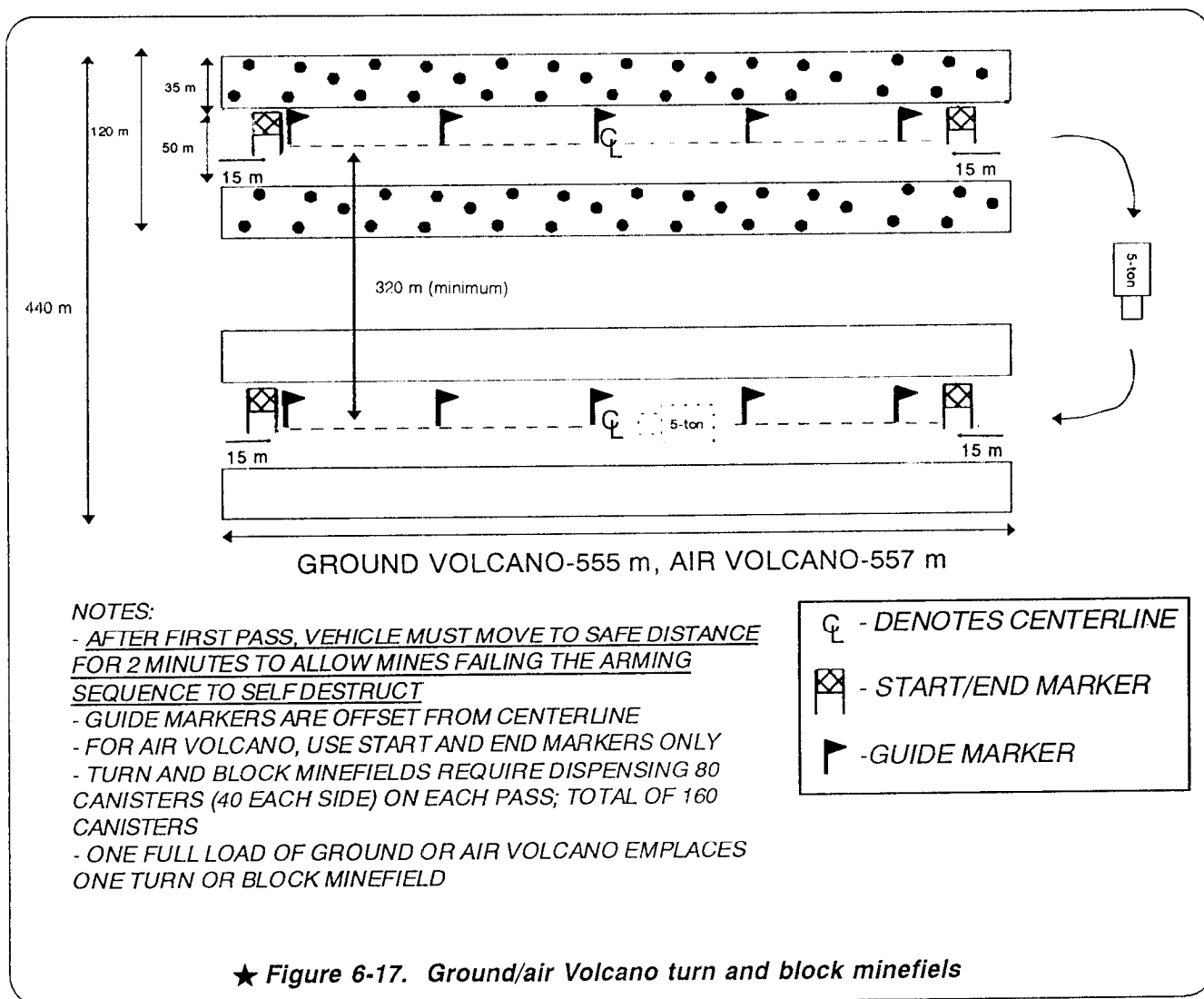

★ taneously on turn and block minefields. When only one ground system is used, the crew must wait four minutes after dispensing the first strip before beginning the second strip. This allows mines failing the arming sequence to self-destruct. For air delivery, two sorties is also optimal; but demands for sorties elsewhere in the division may preclude the simultaneous employment of two Blackhawks.

Table 6-6 summarizes the standard Volcano minefield size, site layout, and resource requirements to emplace disrupt, fix, turn, and block minefields.

### Special consideration for air delivery.

While air delivery is fastest, it is difficult to accurately dispense mines within the confines of the minefield marking. The following discusses techniques unique to air delivery for getting the minefield on target and dispensing the right number of mines.

The desired obstacle effect norms for the air Volcano require extensive premission coordination and positive control during air emplacement. The critical aspect of the air Volcano is getting the right amount of mines in the specified locations and in the desired density. The premission coordination focuses on positive control. Positive control of air Volcano mission requires a redundancy of control techniques to minimize errors in minefield size and location. Positive control techniques must compensate for poor visibility of target, wind speed and direction, and navigational errors.

★ The following positive control techniques are used by the engineer and the air mission commander to ensure Volcano minefields match specific obstacle effect norms. They rely on

these techniques to accomplish the mission, and the techniques are part of the Volcano air mission brief prior to the operation.

- Visual identification.
- Time lapse.
- Doppler guidance system.

★ **Visual identification.** This positive control technique focuses on the visual identification of minefield emplacement. As part of the preparation of a Volcano minefield, an engineer platoon erects airfield panel markers to mark the start and end points. This provides a visual signal for the engineer and air mission commander to start and stop the firing of Volcano canisters. The pilot depresses the launch switch over the first marker and depresses it again over the second marker to terminate the firing. This control technique is good for open terrain with adequate visibility and little canopy coverage.

**Time lapse.** This control technique focuses on when to terminate the firing of Volcano canisters. Once the air Volcano is initiated, terminating the firing depends on the Blackhawk's air speed and the type of minefield (278.7 meter-disrupt/fix or 557.5 meter-turn/block). The air Volcano system has six air speed settings— 20, 30, 40, 55, 80, and 120 knots. Table 6-7 shows the time required to lay the two minefield widths and the full load time. Again, for turn and block minefields, two passes are required. If two Blackhawks with air Volcano systems are avail-

Table 6-6. Volcano minefield data

| Type minefield | Depth (meters) | Front ground/air (meters) | Number strips | Canisters per strip | Total canisters | Minefields per load |
|----------------|----------------|---------------------------|---------------|---------------------|-----------------|---------------------|
| Disrupt        | 120            | 277/278                   | 1             | 40 (20 each side)   | 40              | 4                   |
| Fix            | 120            | 277/278                   | 1             | 40 (20 each side)   | 40              | 4                   |
| Turn           | 320            | 555/557                   | 2             | 80 (40 each side)   | 160             | 1                   |
| Block          | 320            | 555/557                   | 2             | 80 (40 each side)   | 160             | 1                   |

able, they can work in pairs and lay one minefield with one pass, dispensing 80 canisters each.

The following example is provided to show how Table 6-7 is used:

The air Volcano mission is to install a disrupt minefield. The Blackhawk is traveling at 40 knots (this is entered on the DCU) and is initiated (launch switch is depressed) at the identification of Volcano start marker (or Doppler data discussed below) on the ground. The engineer or the air mission commander depresses the launch switch the second time after 13 seconds.

Number of canisters fired. This positive control technique focuses on when to terminate

the firing of Volcano canisters. Once the air Volcano is initiated, terminating the firing depends on the number of Volcano canisters dispensed. The disrupt or fix Volcano minefield requires 40 canisters, and the turn or block minefield requires 80 canisters on one pass (see Table 6-6, page 6-27). On the DCU, there is a canisters remaining digital readout for the left and right side. The engineer and the air mission commander terminate the firing after reaching the designated number of canisters required.

Using the disrupt minefield example above, the Blackhawk started the mission with a full load— 80 canisters on each side. The engineer or air mission commander initiates (launch switch depressed) at the identification of Volcano start marker (or Doppler data) on the

Table 6-7. Air Volcano dispensing times based on air speed

AIR VOLCANO STANDARD MINEFIELDS

| KNOTS                | DISRUPT & FIX MINEFIELD | TURN & BLOCK MINEFIELD | 160 CANISTERS LOAD |
|----------------------|-------------------------|------------------------|--------------------|
| 20                   | 27 SECONDS              | 54 SECONDS             | 108 SECONDS        |
| 30                   | 18 SECONDS              | 36 SECONDS             | 72 SECONDS         |
| 40                   | 13 SECONDS              | 27 SECONDS             | 54 SECONDS         |
| 55                   | 9 SECONDS               | 18 SECONDS             | 39 SECONDS         |
| 80                   | 6 SECONDS               | 13 SECONDS             | 27 SECONDS         |
| 120                  | 4 SECONDS               | 9 SECONDS              | 18 SECONDS         |
| WIDTH OF MINFIELD    | 278.7 METERS            | 557.5 METERS           | 1115 METERS        |
| # PASSES PER MF      | 1                       | 2 (SEE NOTE)           | 1                  |
| # CANISTERS PER PASS | 40 CANISTERS            | 80 CANISTERS           | 160 CANISTERS      |

RECOMMENDED AIR SPEED

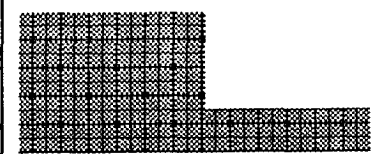

AIR SPEED NOT RECOMMENDED

NOTE: BLACKHAWKS IN PAIRS CAN LAY TURN & BLOCK MF IN ONE PASS FIRING 80 CANISTERS EACH

ground. The engineer or the air mission commander depresses the launch switch the second time after 20 canisters have been expended on each side (total of 40). The digital readout that would trigger the depression of the launch switch is *left 60 right 60*.

Ideally, the timing of delivery and the number of canisters fired are done simultaneously. As the engineer or the air mission commander counts down the time over target, they monitor the DCU readout on the canisters remaining.

**Doppler guidance system.** This positive control technique focuses on when to initiate and terminate the firing of Volcano canisters using the Blackhawk's Doppler navigation set. The Doppler navigation set provides present position or destination navigation information in latitude and longitude (degrees and minutes) or universal transverse mercator (grid) (UTM) coordinates. As part of the preparation for the air Volcano minefield, exact coordinates are determined for the approach and the limits of the minefield. During the air mission brief, these grids are given to the air mission commander. The air mission commander enters those grids into his Doppler navigation set.

During execution, the air mission commander monitors the Doppler and can estimate time to target, and when to initiate, and can terminate the firing of the Volcano canisters.

**Premission coordination.** If air Volcano has been allocated to a unit, an ALO will conduct initial coordination with the S3 air, engineer, and air defense officer. During this meeting, air Volcano requirements are outlined. Listed below are the critical items that must be discussed.

**Logistical requirements.** The engineer must provide the ALO the location of the Class IV/V supply point where the Blackhawk will be loaded, reporting time, and approach direction. The ALO must provide the amount of air time available and be prepared to discuss emplacement times based on Volcano locations.

**Concept of the operation.** The scheme of maneuver, fires, and engineer operations are outlined. The scheme of engineer operations outlines exact grid coordinates, obstacle in-

tents, and minefield composition and size. The air Volcano can be emplaced during the preparation time or under enemy contact. Additional control measures must be emplaced if the air Volcano is emplaced under contact (possibly informal airspace coordination area). If the air Volcano is triggered by enemy action, the decision support template (DST) must be briefed outlining named area of interest (NAIs), tactical area of interest (TAIs), decision points, and execution criteria.

**Volcano control points/markers.** The initial point (IP), approach marker, and minefield markers are designated. The IP is usually an easily identifiable terrain feature for the coordination of the entry point of the Blackhawk in sector. The approach marker allows the Blackhawk to set altitude, air speed, and final orientation to the minefield. The approach marker could be an easily identifiable terrain feature. Minefield markers establish the limits of the desired minefield. Approach and minefield markers must be visible from the air and distinctly different. Sketches of the minefield are provided to the ALO. The sketches include minefield location, probable enemy location, identifiable terrain features, IP, direction and distance from IP to minefield, and location of Class IV/V supply point (if resupply is required).

**Command and control.** Radio frequencies, points of contact (air mission commander and designated engineer platoon leader), code words, identification, friendly or foe (radar) (IFF) mode and challenge, and password are exchanged.

**Air mission brief.** Updates and changes to the situation are exchanged between the engineer platoon leader and the air mission commander as Volcano canisters are being loaded. The engineer and the air mission commander use the four positive control techniques to ensure mission success. The primary technique and responsibilities for each control technique are outlined in the air mission brief. The Blackhawk crew chief can also assist in monitoring one of the positive control techniques. For example, during the air mission brief, the air mission commander states that strong variable headwinds will be encountered, and the approach to Volcano markers will be obscured

due to the amount of foliage. The engineer and the air mission commander designate that the Doppler system will be the primary positive control technique, with the time lapse and canister countdown as backup. The air mission commander will initiate the firing, while the engineer will terminate the firing. The grid coordinates for the initial point, approach marker, and start and stop markers are entered into the Doppler system. As a backup, the air mission commander will terminate the firing based on Doppler data. In this scenario, the engineer platoon leader and the air mission commander create redundancy in positive control techniques.

## MOPMS

The MOPMS is a man-portable, 162-pound, suitcase-shaped mine dispenser (Figure 6-18) that can be emplaced anytime before dispensing mines. The dispenser contains 21 mines (17 ATs and 4 APs). Mines have finger-like leaf springs along their outer circumference. The springs are designed to push the mine into proper orientation if it lands on its side.

Each dispenser contains seven tubes; three mines are located in each tube. When dispensed, an explosive propelling charge at the bottom of each tube expels mines through the container roof. Mines are propelled 35 meters from the container in a 180-degree semicircle (Figure 6-19). The resulting density is 0.01 mine per square meter. The safety zone around one container is 55 meters to the front and sides of the container and 20 meters to the rear.

Mines are dispensed on command using an M71 remote control unit (RCU) or an electronic initiating device, such as the M34 hand-blasting machine connected to the container by field wire. Once mines are dispensed, they cannot be recovered or reused. If mines are not dispensed, the container may be disarmed and recovered for later use.

The RCU can recycle the 4-hour self-destruct time of the mines three times, for a total duration of 16 hours (4 hours after initial launch and three 4-hour recycles). This feature makes it possible to keep the minefield emplaced for

longer periods, if necessary. The RCU can also self-destruct mines on command. It allows a unit to counterattack or withdraw through the minefield, as necessary, rather than wait until the self-destruct time has expired. The RCU can control up to 15 containers or groups of containers via separate pulse-coded frequencies, out to 300 to 1,000 meters. Coded frequencies defeat threat electronic countermeasures directed against the system.

If the M71 RCU is not available, a direct wire link is used in conjunction with the M32, M34, or M57 blasting machine. Using the M32 10-cap blasting machine, one MOPMS dispenser can be detonated at a maximum range of 1,000 meters. The M34 50-cap blasting machine can detonate one MOPMS at a maximum range of 3,000 meters. (Due to internal resistance, the maximum range is decreased by 400 meters for each additional MOPMS connected in series.) The M57 Claymore-type firing device can fire only one MOPMS at a maximum range of 100 meters. When controlled by direct wire, MOPMS dispensers cannot be command-detonated, and the self-destruct time cannot be recycled.

The MOPMS dispenser has seven launch tubes. If **all** seven tubes are not visible after deployment or upon later inspection, mines are jammed in the tube(s). In this event, clear the area and notify EOD. The dispenser is considered as unexploded ordnance. Do not attempt to recover the dispenser.

### Employment.

The MOPMS provides a self-contained, on-call minefield emplacement capability for all forces. It can be command-detonated, reused (if mines are not dispensed), and directly emplaced to provide complete and certain coverage of small or critical targets. The ability to command detonate mines or extend their self-destruct time provides an added flexibility not currently available with other scatterable mine systems. With its unique characteristics, the MOPMS is ideally suited for the following minefield missions:

- Close gaps or lanes in existing minefields.
- Hasty protective minefields.

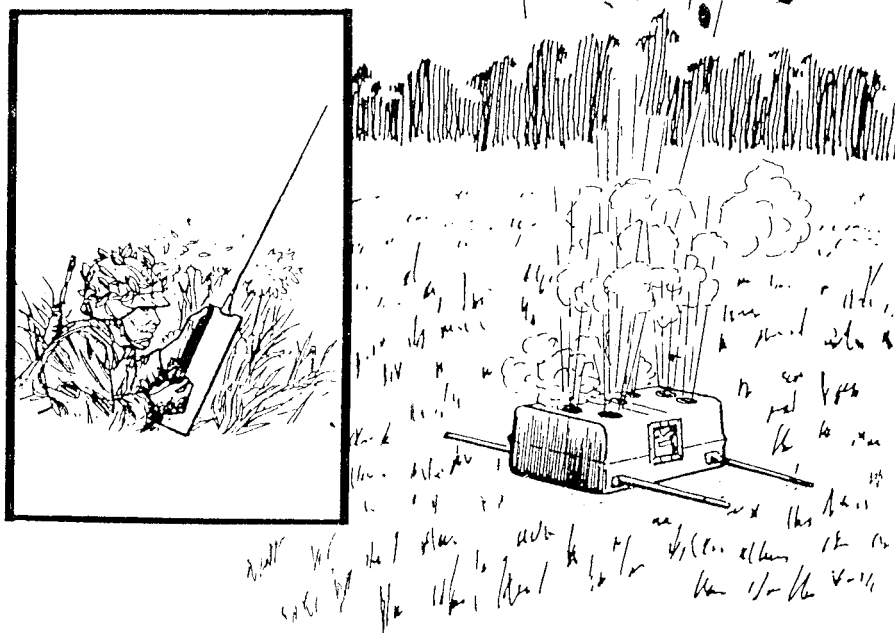

Figure 6-18. Modular Pack Mine System (MOPMS)

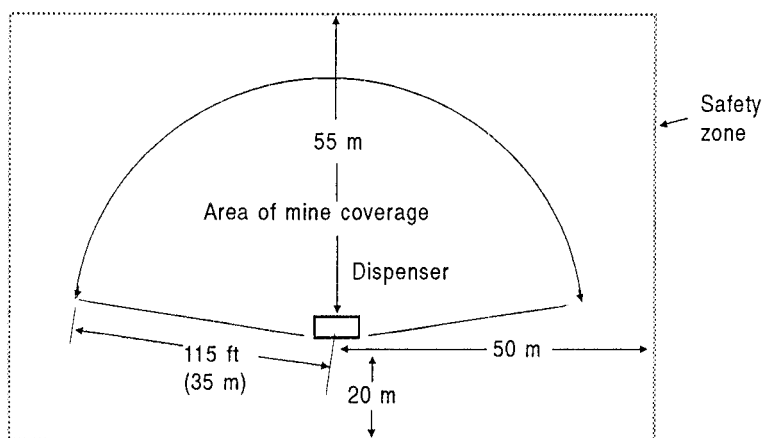

Figure 6-19. MOPMS dispenser emplacement and safety zone



- Deliberate protective minefields (cases emplaced but mines not dispensed).
- Nuisance minefields (trails, crossing sites, LZs/DZs, and road junctions).
- Ambushes and booby traps.
- Tactical minefields intended to disrupt or fix.
- In support of MOUT operations.

When the MOPMS is used to close lanes, the container is positioned and dispensed by personnel in an overmatching position from a safe standoff. The MOPMS is ideally suited for creating a small disrupting obstacle in support of engineers blowing a reserved demolition. Engineers prepare the reserved target for demolition and emplace several MOPMS units on the enemy side, just out of target range. When the last forward elements pass through the target, the firing party detonates charges. If something goes wrong or the firing party needs more time, MOPMS mines can be dispensed to disrupt the enemy before they reach the target.

The MOPMS provides light forces and special forces with a versatile, compact system for emplacing nuisance minefields. It can be used in low-, mid-, and high-intensity conflicts and in a variety of environments. Its major limitation is the requirement to transport the system using a vehicle, helicopter, or fixed-wing aircraft.

### Emplacement.

MOPMS dispensers are issued as standard Class V munitions and are drawn from an ASP on a mission basis. RCUs are organizational issues of equipment and are assigned to engineer and combat arms units. Due to the weight of the system, it will normally be transported by vehicle, as close as possible to the emplacement site where it can easily be hand-emplaced by four soldiers using the four foldout carrying handles.

To ensure the minefield will be dispensed in the proper location, the container should be carefully sited by the NCOIC. Several con-

tainers can be used together to provide a greater area of coverage or higher mine density, if desired. If mines are not dispensed immediately, containers should be camouflaged and, if possible, buried. When placed in sand or snow, brace the container to prevent it from moving during mine dispensing. Designate a firing point that gives the operator clear observation of the area to be mined. Firing systems must be inspected according to MOPMS operating instructions. If mines are dispensed immediately, empty containers are removed to avoid revealing the minefield location.

The MOPMS can be employed to emplace tactical minefields with a disrupt or fix effect. Emplacement procedures are the same as above. However, MOPMS containers are arranged in a specific pattern to achieve the necessary depth, frontage, and density. Once the minefield is marked (to include the safety zone), MOPMS containers are arranged as shown in Figure 6-20. The safety zone is 55 meters to the front and sides of the MOPMS container and 20 meters behind the container. The disrupt minefield uses four MOPMS containers spaced 70 meters apart to give a minefield frontage of 280 meters (not including the safety zone). Every other container is offset from the baseline 35 meters to give the minefield a depth of 70 meters (not including the safety zone). All containers are fired using the same RCU or other firing device.

Figure 6-21 illustrates the arrangement of MOPMS containers to achieve a fix minefield. The basic layout is the same as the disrupt minefield. However, the fix minefield uses one additional MOPMS placed 70 meters forward of the baseline to act as an IOE. This gives the same 280-meter frontage but increases the depth of the minefield to 115 meters (not including the safety zone).

MOPMS can be used to construct turn and block tactical minefields using the principles outlined in Chapter 2. However, turn and block minefields require more containers than are normally available to a unit.

