

## IGNITION #3 - DISTRIBUTOR AND DISTRIBUTORLESS TYPES

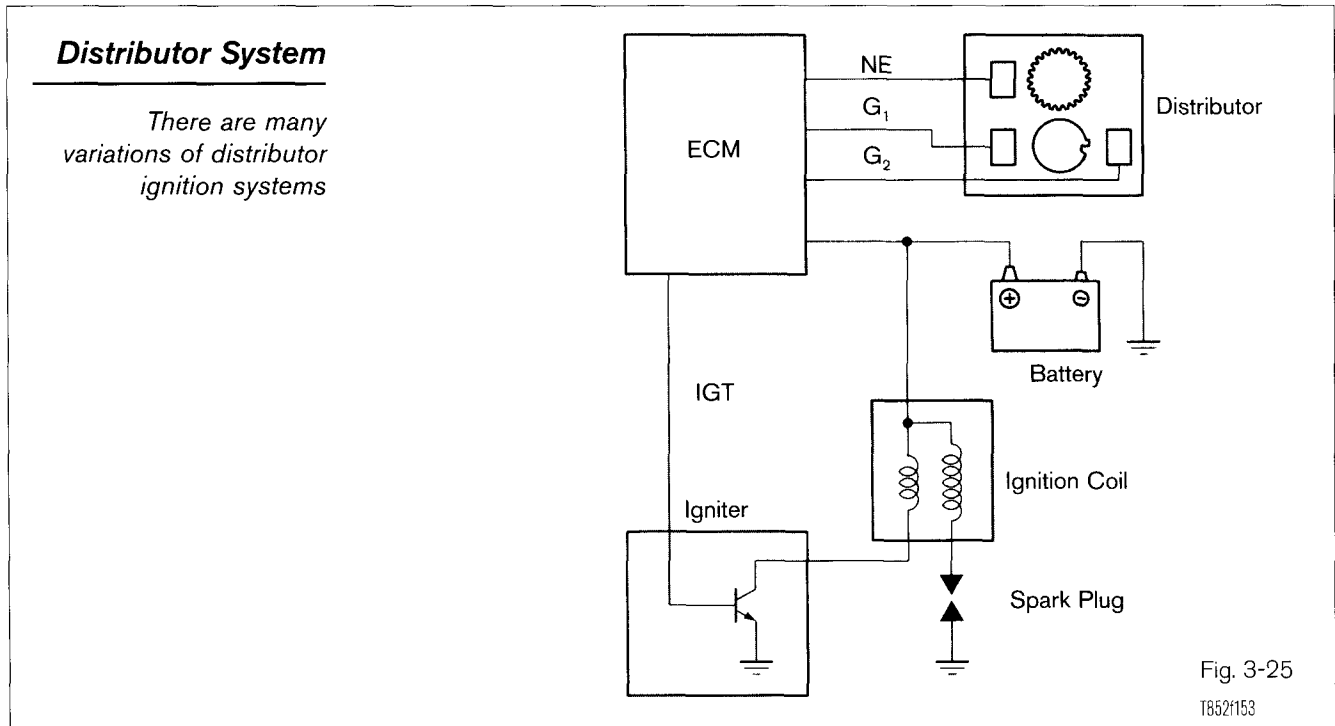

### Distributor Ignition (DI) Systems

The NE signal is generated by the Crankshaft Position Sensor (also called engine speed sensor). The G signal is generated by the Camshaft Position sensor that may be located in the distributor or on the engine.

## IGNITION #3 - DISTRIBUTOR AND DISTRIBUTORLESS TYPES

### Distributor

*This distributor has two G signal pick up coils and an NE signal rotor.*

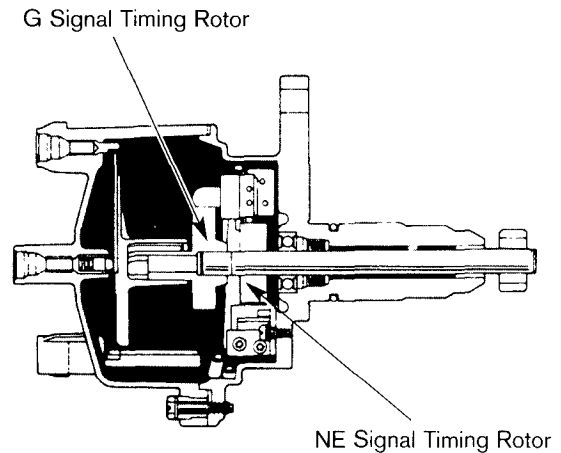
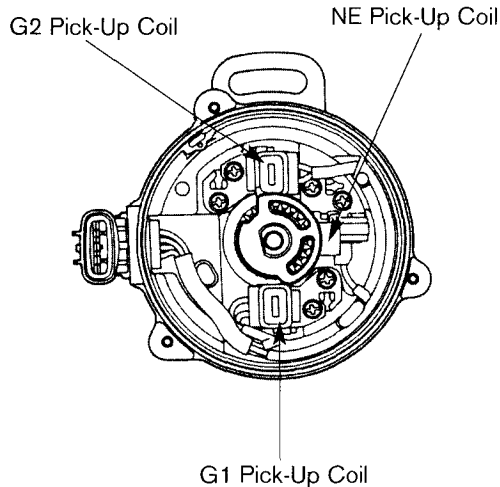

Fig. 3-26

T8521154/T8521155

### Distributor System Circuit

*The IGT signal turns the igniter on and off at the correct time for ignition to occur.*

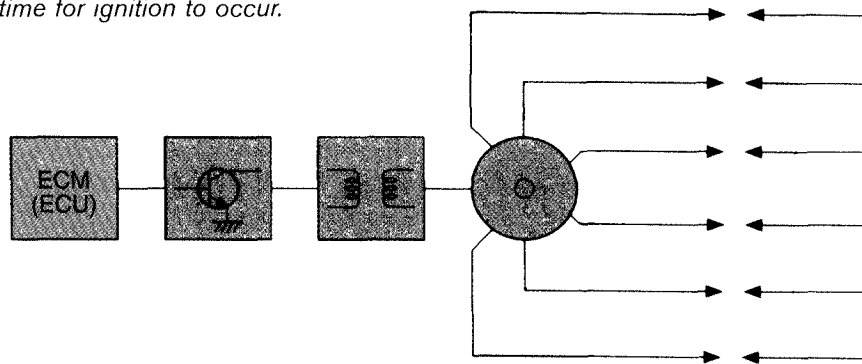

Fig. 3-27

T8521156

At the appropriate time during cylinder compression, the ECM sends a signal called IGT to the igniter. This will turn on the transistor in the igniter sending current through the primary winding of the ignition coil. At the optimum time for ignition to occur, the ECM will turn off IGT and the transistor will turn off current flow through the primary winding. The induced current will travel through the coil wire, to the distributor cap, rotor, to the distributor terminal the rotor is pointing at, high tension wire, spark plug, and ground. The rotor position determines the cylinder that receives the spark.

## IGNITION #3 - DISTRIBUTOR AND DISTRIBUTORLESS TYPES

---

### Firing Order

The firing order can be found in the New Car Features book. The cylinders are identified as follows:

- V-8 engine cylinders are numbered with odd numbered cylinders on the left bank and even numbered cylinders on the right bank.
- V-6 engine cylinders are numbered with even on left bank and odd numbered cylinders on the right bank.
- In-line 6 engines are numbered consecutively 1-6, with the number 1 cylinder at the front.
- Four cylinder engines are numbered consecutively from front to back.

Many times, original equipment distributor caps have the firing order molded into the cap.

### Firing Order

<b>Engine Configuration</b>	<b>Firing Order</b>
<b>V-8</b>	<b>1-8-4-3-6-5-7-2</b>
<b>V-6</b>	<b>1-2-3-4-5-6</b>
<b>In-line 6</b>	<b>1-5-3-6-2-4</b>
<b>In-line 4</b>	<b>1-3-4-2</b>

Fig. 3-28

# IGNITION #3 - DISTRIBUTOR AND DISTRIBUTORLESS TYPES

## V-6 Cylinder Identification

Note that the cylinder numbering is opposite the V-8.

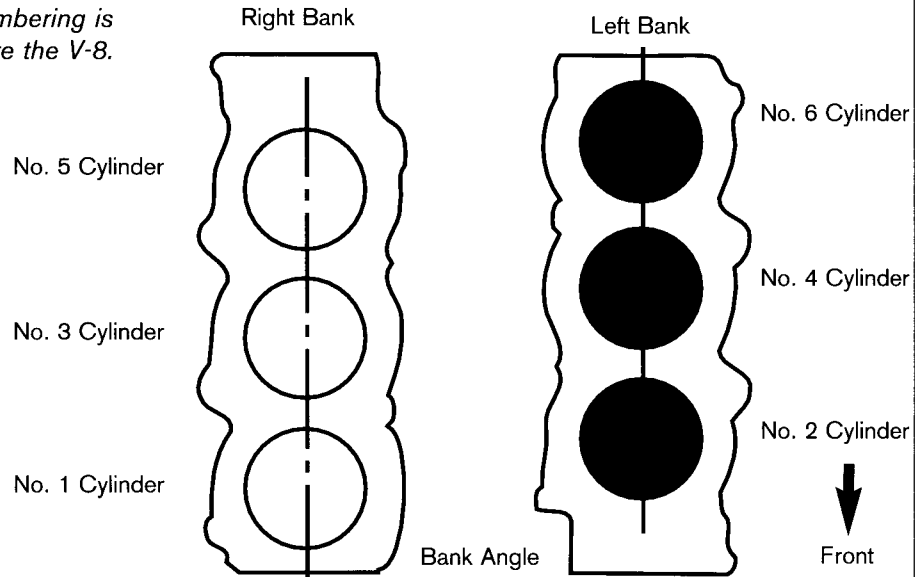

Fig. 3-29  
T8521157

## V-8 Cylinder Identification

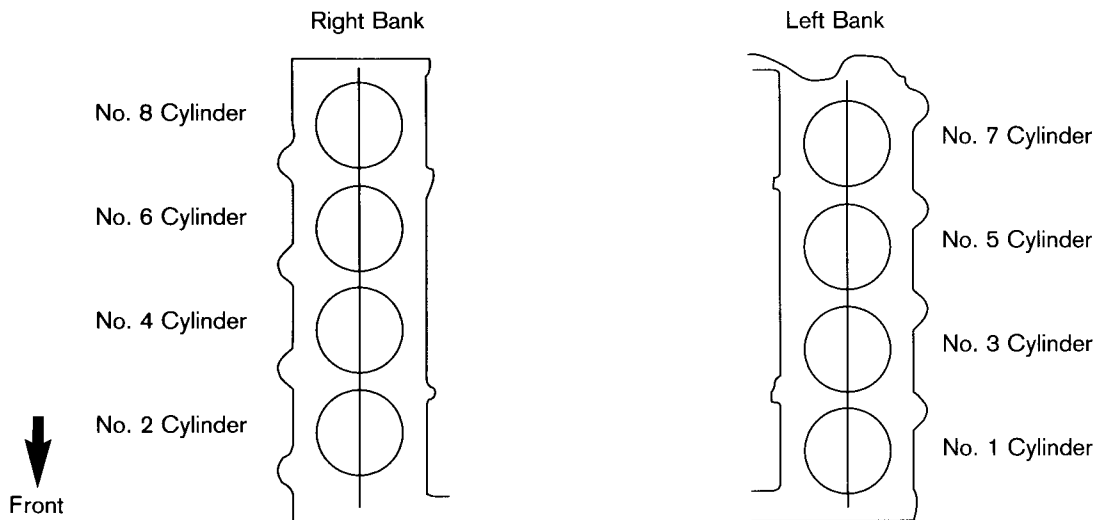

Fig. 30  
T8521158

## IGNITION #3 - DISTRIBUTOR AND DISTRIBUTORLESS TYPES

### Distributorless & Direct Ignition Systems Overview

Essentially, a Distributorless Ignition System is an ignition system without a distributor. Eliminating the distributor improved reliability by reducing the number of mechanical components. Other advantages are:

- Greater control over ignition spark generation - There is more time for the coil to build a sufficient magnetic field necessary to produce a spark that will ignite the air/fuel mixture. This reduces the number of cylinder misfires.
- Electrical interference from the distributor is eliminated - Ignition coils can be placed on or near the spark plugs. This helps eliminate electrical interference and improve reliability.
- Ignition timing can be controlled over a wider range - In a distributor, if too much advance is applied the secondary voltage would be directed to the wrong cylinder.

All of the above reduces the chances of cylinder misfires and consequently, exhaust emissions.

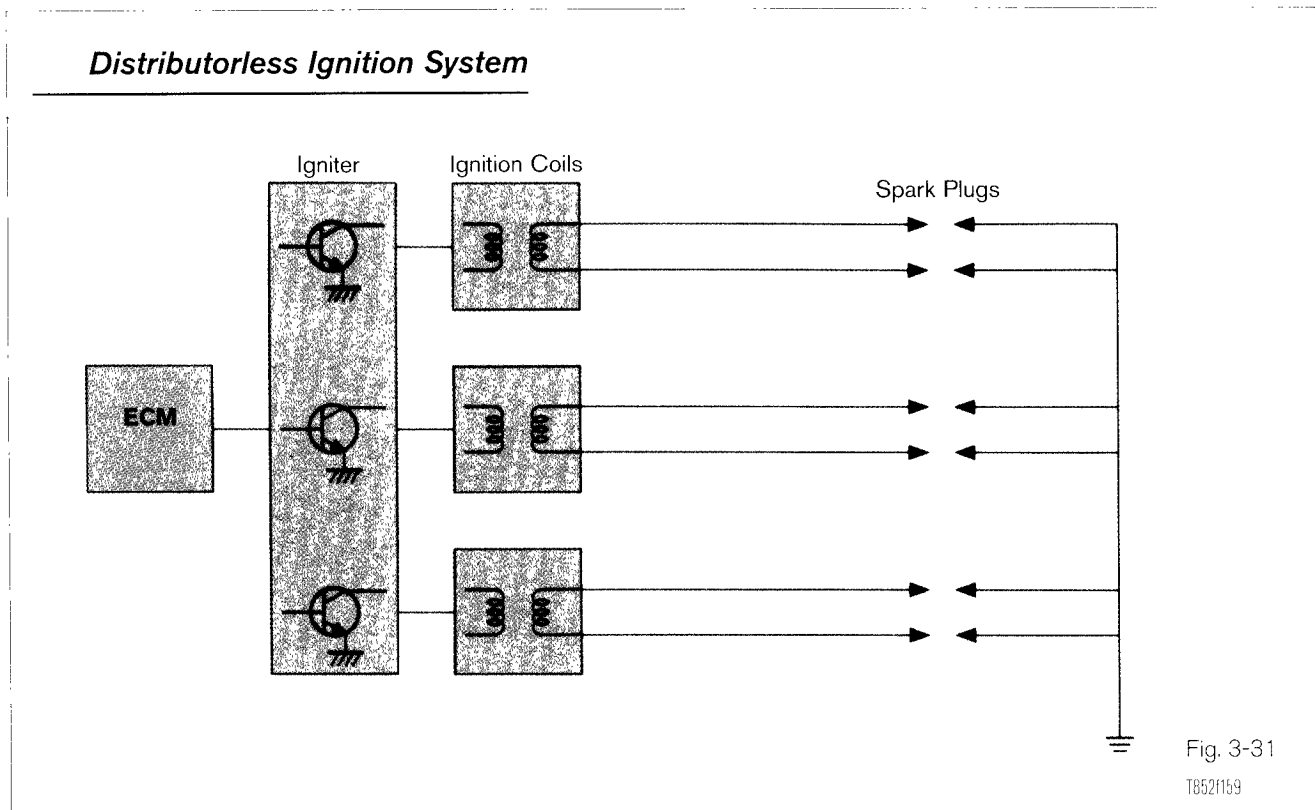

Distributorless Ignition systems are usually defined as having one ignition coil with two spark plug wires for two cylinders. Distributorless Ignition Systems use a method called simultaneous ignition (also called waste spark) where an ignition spark is generated from one ignition coil for two cylinders simultaneously.

## IGNITION #3 - DISTRIBUTOR AND DISTRIBUTORLESS TYPES

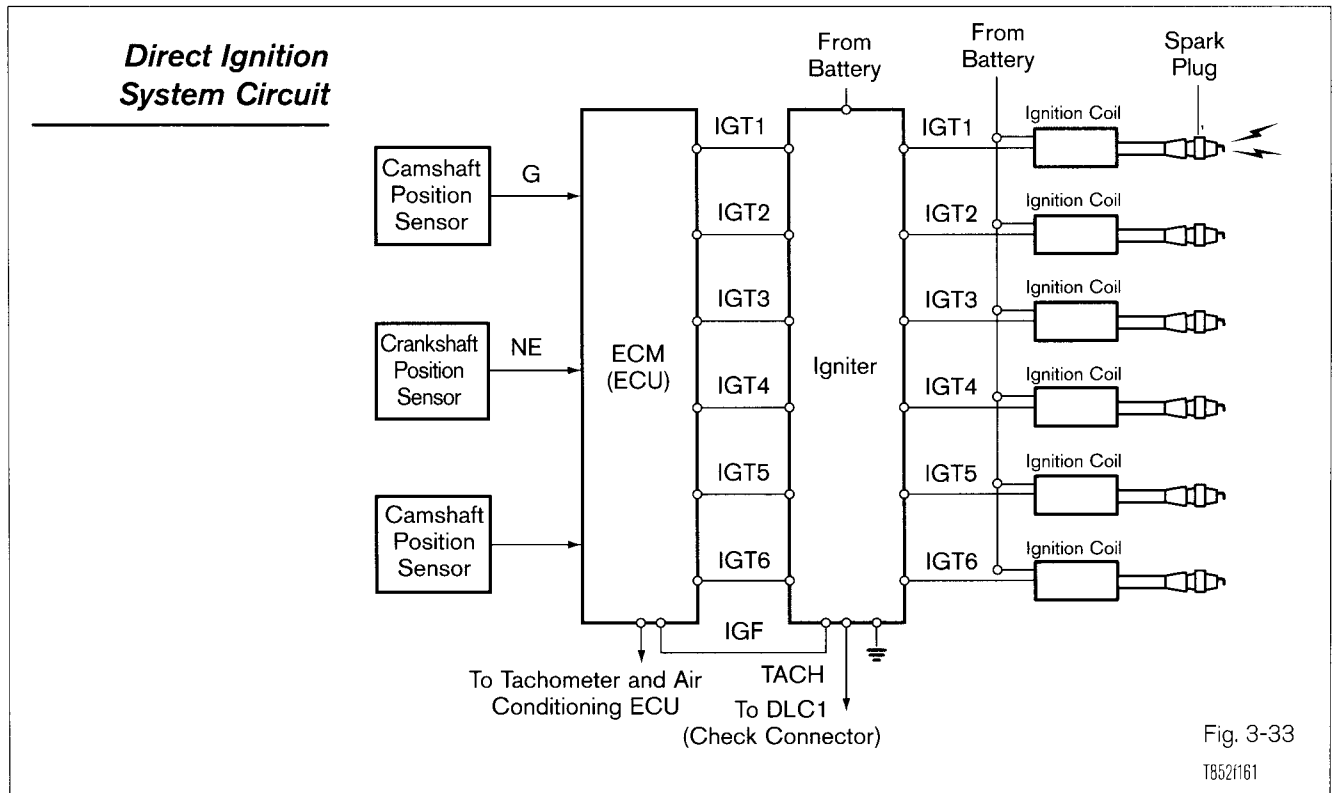
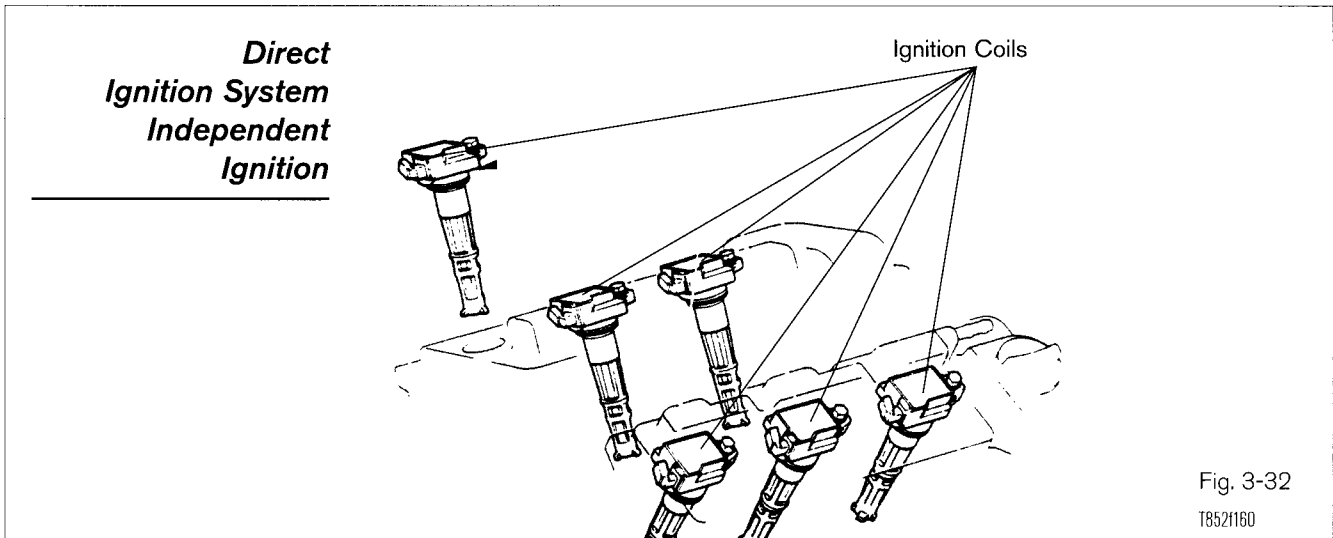

Direct Ignition Systems (DIS) have the ignition coil mounted on the spark plug. DIS can come in two forms:

- **Independent ignition** - one coil per cylinder.
- **Simultaneous ignition** - one coil for two cylinders. In this system an ignition coil is mounted directly to one spark plug and a high tension cord is connected to the other spark plug. A spark is generated in both cylinders simultaneously.

## IGNITION #3 - DISTRIBUTOR AND DISTRIBUTORLESS TYPES

### Direct Ignition System (DIS) Simultaneous Ignition

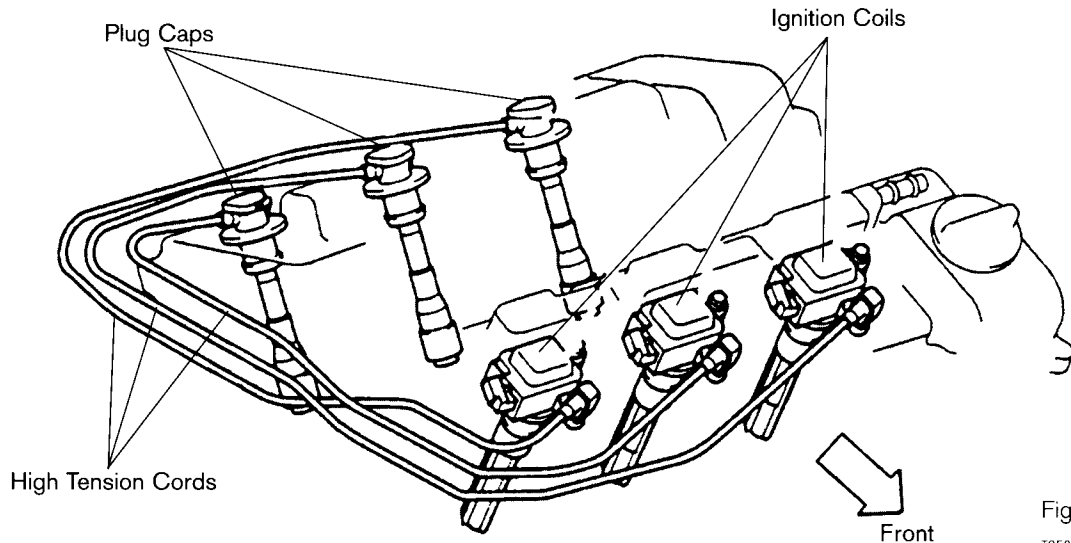

Fig. 3-34  
T852f162

### Distributorless Ignition System Circuit

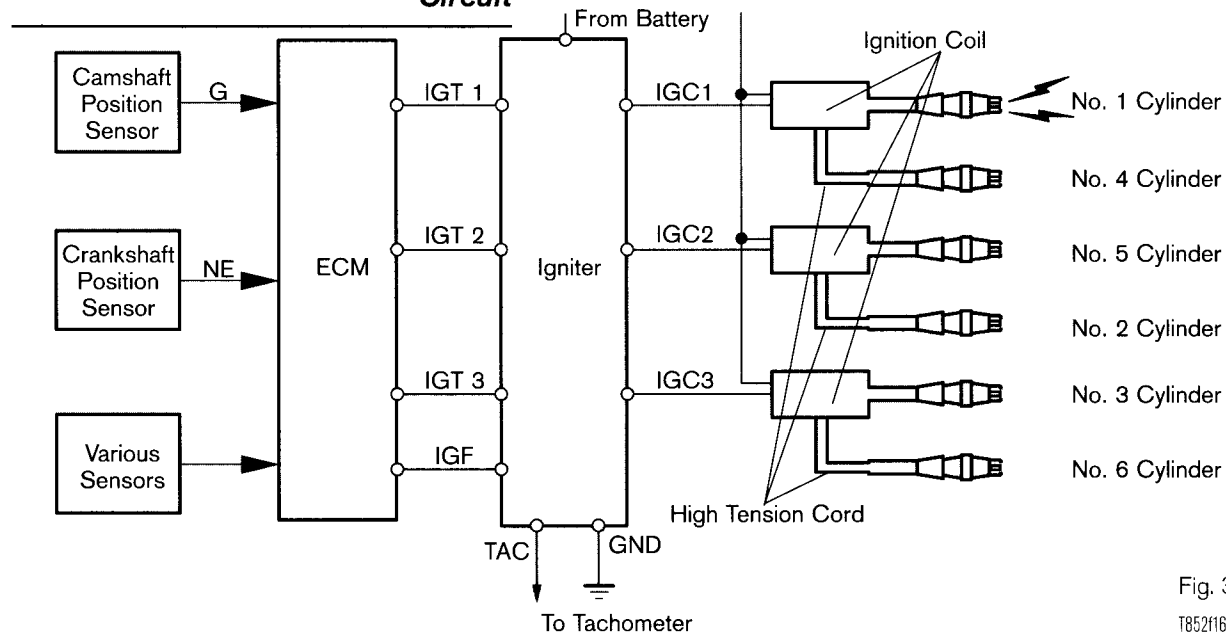

Fig. 3-35  
T852f163

### Distributorless (Simultaneous Ignition) Operation

Distributorless Ignition Systems and Direct Ignition Systems that use one coil for two cylinders use a method known as simultaneous ignition. With simultaneous ignition systems, two cylinders are paired according to piston position. This has the effect simplifying ignition timing and reducing the secondary voltage requirement.

## IGNITION #3 - DISTRIBUTOR AND DISTRIBUTORLESS TYPES

For example, on a V-6 engine, on cylinders one and four, the pistons occupy the same cylinder position (both are at TDC and BDC at the same time), and move in unison, but they are on different strokes. When cylinder one is on the compression stroke, cylinder four is on the exhaust stroke, and vice versa on the next revolution.

### Simultaneous Ignition Sequence

*Two cylinders simultaneously will have spark, though only one cylinder will be on the compression stroke. Note that cylinders 2 and 5 both have spark, but cylinder No. 5 is compression. One crankshaft revolution later cylinder No. 3 is on compression.*

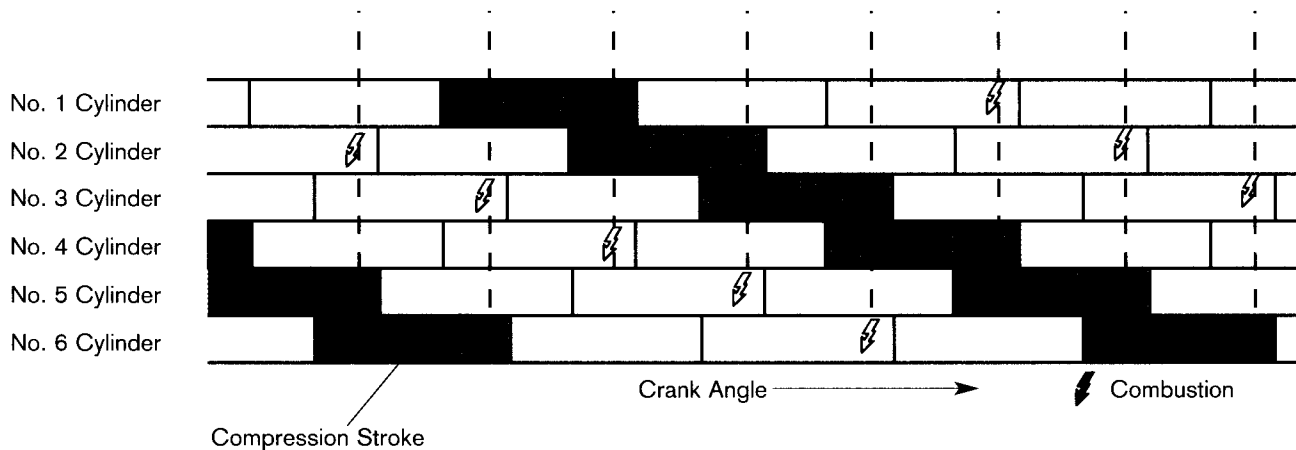
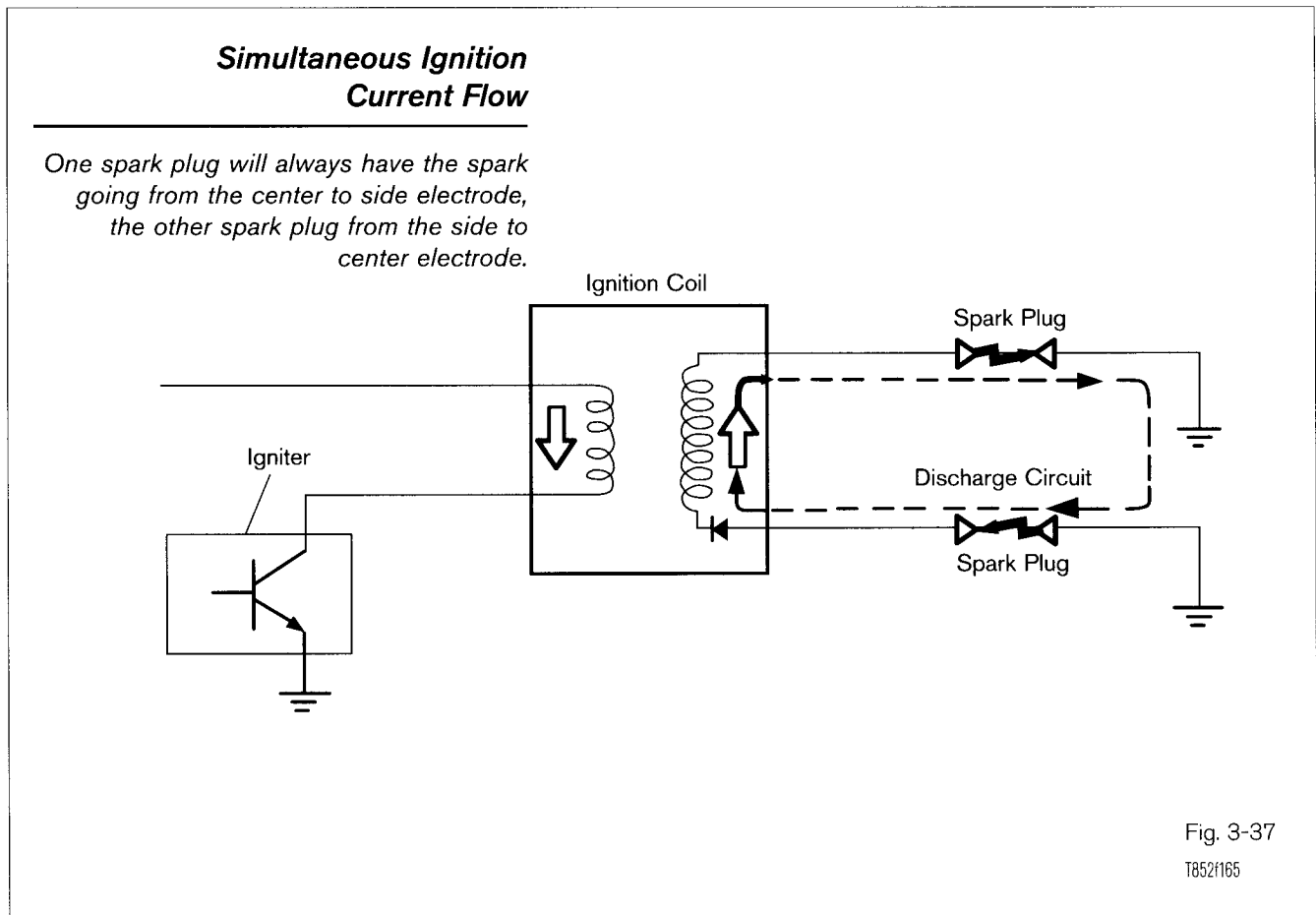

Fig. 3-36  
T8521164

The high voltage generated in the secondary winding is applied directly to each spark plug. In one of the spark plugs, the spark passes from the center electrode to the side electrode, and at the other spark plug the spark is from the side to the center electrode.



## IGNITION #3 - DISTRIBUTOR AND DISTRIBUTORLESS TYPES



Typically, the spark plugs with this style of ignition system are platinum tipped for stable ignition characteristics.

The voltage necessary for a spark discharge to occur is determined by the spark plug gap and compression pressure. If the spark plug gap between both cylinders is equal, then a voltage proportional to the cylinder pressure is required for discharge. The high voltage generated is divided according to the relative pressure of the cylinders. The cylinder on compression will require and use more of the voltage discharge than the cylinder on exhaust. This is because the cylinder on the exhaust stroke is nearly at atmospheric pressure, so the voltage requirement is much lower.

When compared to a distributor ignition system, the total voltage requirement for distributorless ignition is practically the same. The voltage loss from the spark gap between the distributor rotor and cap terminal, is replaced by the voltage loss in the cylinder on the exhaust stroke in the Distributorless Ignition System.

# IGNITION #3 - DISTRIBUTOR AND DISTRIBUTORLESS TYPES

## Direct Ignition System (DIS)

As DIS has evolved, there have been changes to the function and location of the igniter. With independent ignition DIS, there may be one igniter for all cylinders or one igniter per cylinder. On simultaneous ignition DIS there is one igniter for all coils. The following gives an overview of the different types used on various engines.

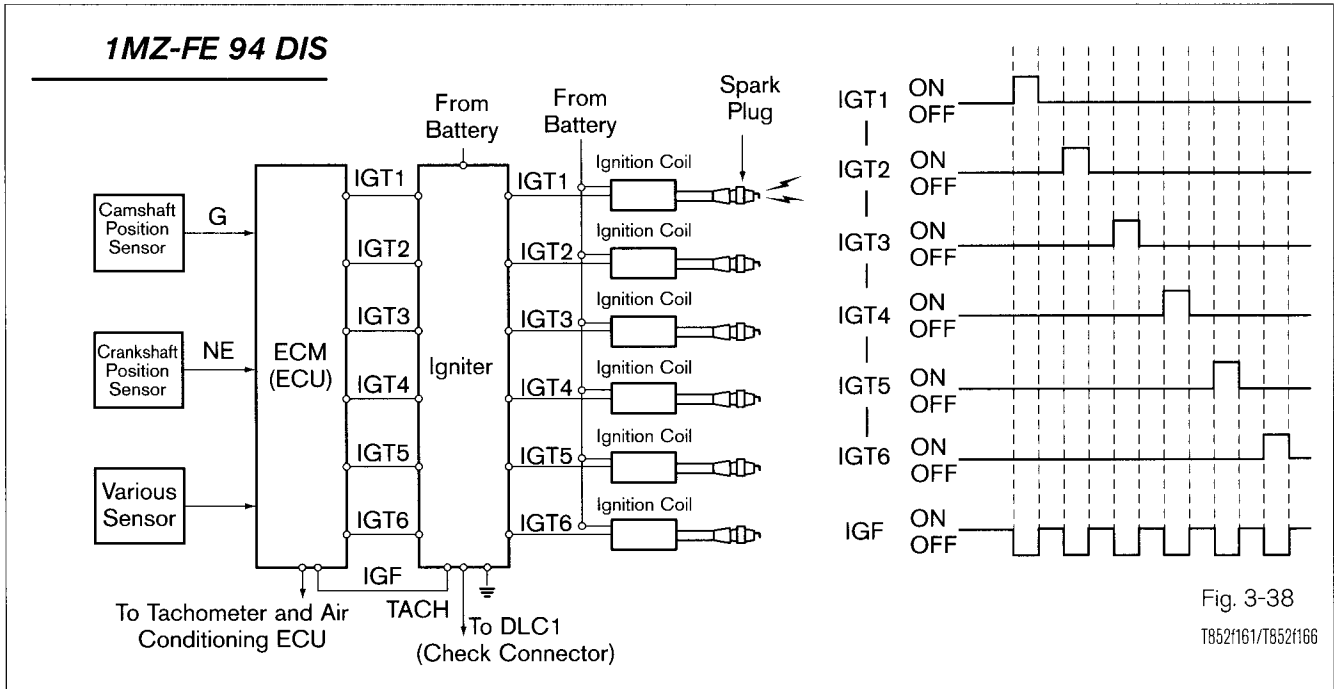

## 1 MZ-FE 94 DIS

This DIS uses one igniter for all coils. The IGF signal goes low when IGT is turned on. The coils in this system use a high voltage diode for rapid cutoff of secondary ignition. If a coil is suspected of being faulty, swap with another coil.

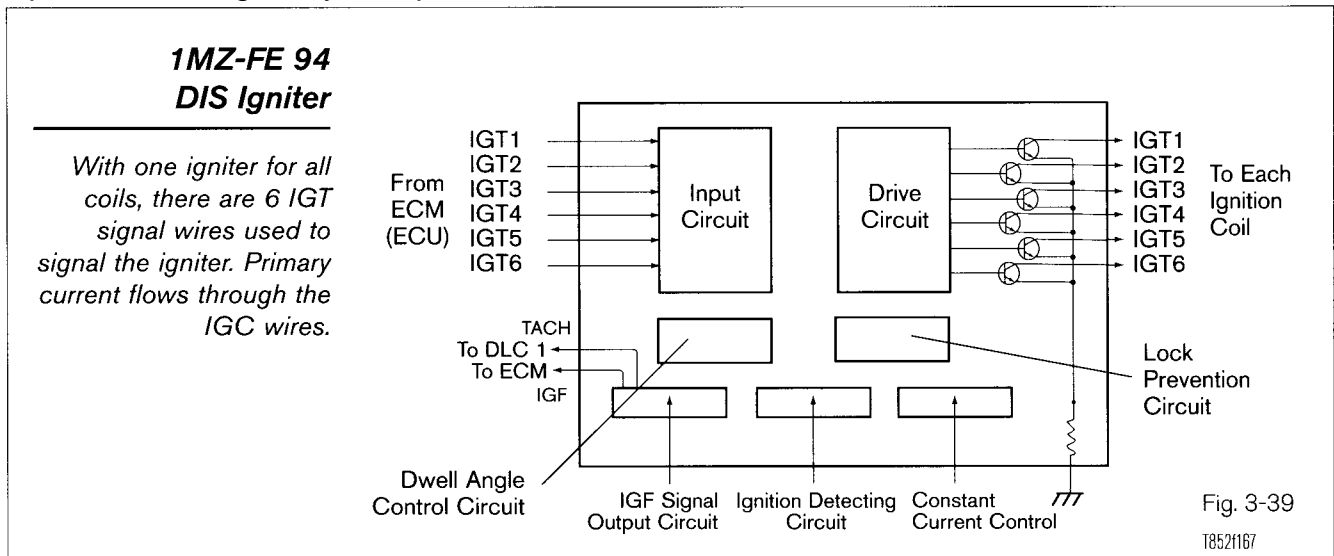

# IGNITION #3 - DISTRIBUTOR AND DISTRIBUTORLESS TYPES

## Ignition Coil with Diode

With the diode in the circuit, it is recommended to swap coils to test for a faulty coil.

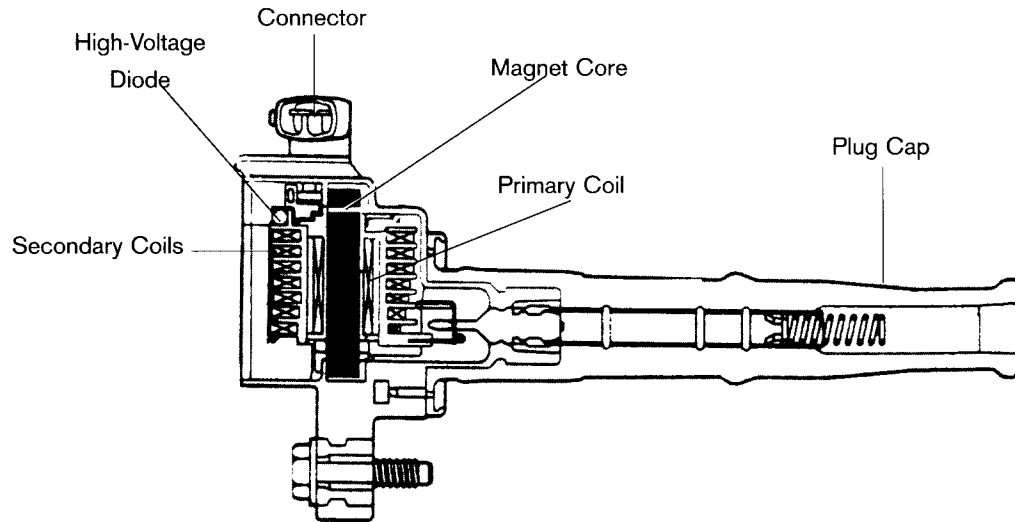

Fig. 3-40  
T8521168

## High Voltage Diode

The diode is in the secondary circuit.

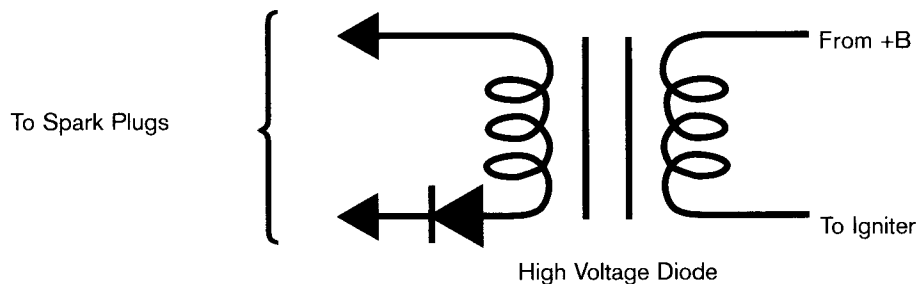

Fig. 3-41  
T8521169

## 1 MZ-FE with DIS Simultaneous Ignition

This system uses three IGT signals to trigger the ignition coils in the proper sequence. When a coil is turned on, IGF goes low.

# IGNITION #3 - DISTRIBUTOR AND DISTRIBUTORLESS TYPES

## 1MZ-FE with DIS Simultaneous Ignition

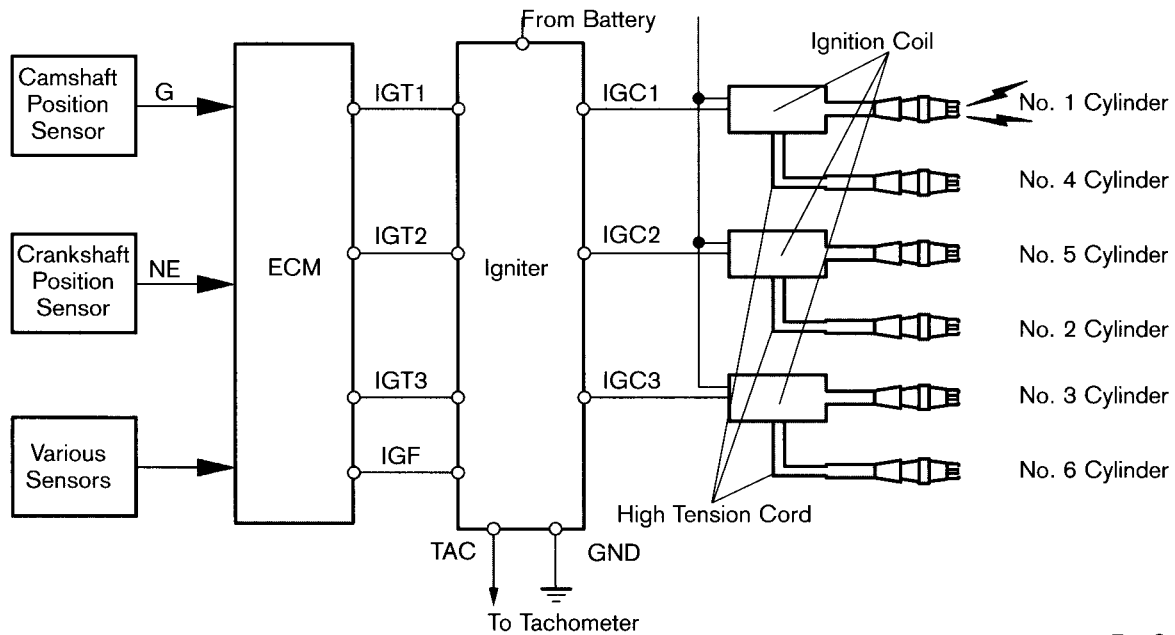

Fig. 3-42  
T8521163

## Igniter

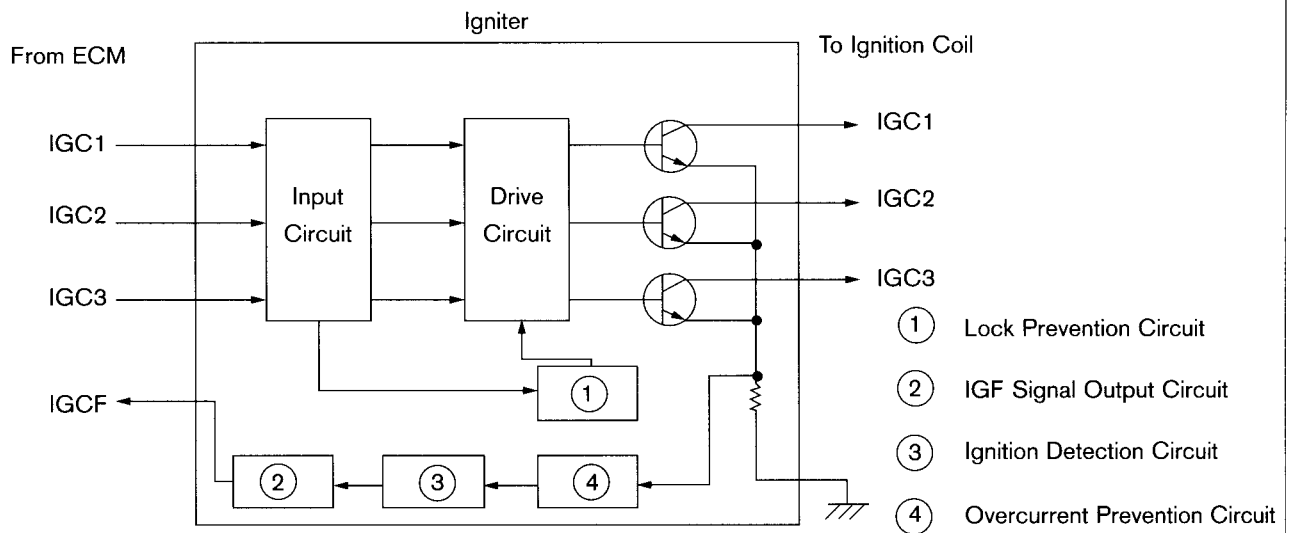

Fig. 3-43  
T8521170

# IGNITION #3 - DISTRIBUTOR AND DISTRIBUTORLESS TYPES

## V-6 Igniter Sequence

When a coil is turned on, IGF goes low.

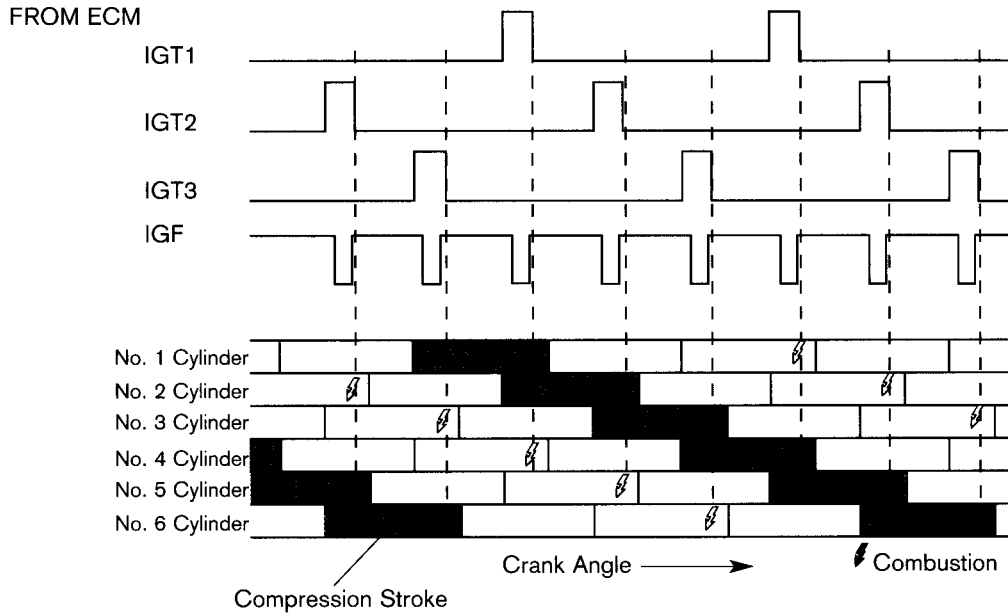

Fig. 3-44

T8521164

## In-Line 6 Cylinder

The in-line 6 has a different firing order and cylinders are paired differently.

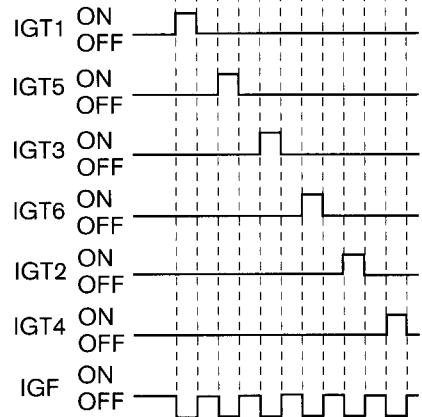
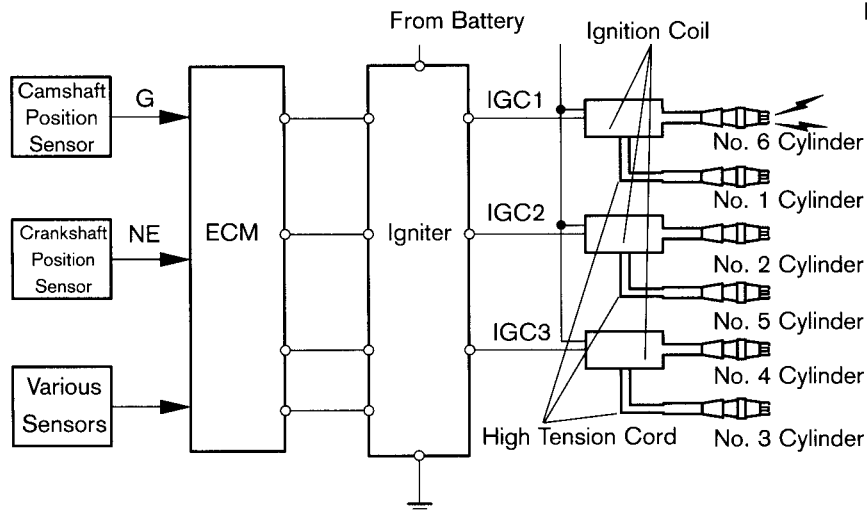
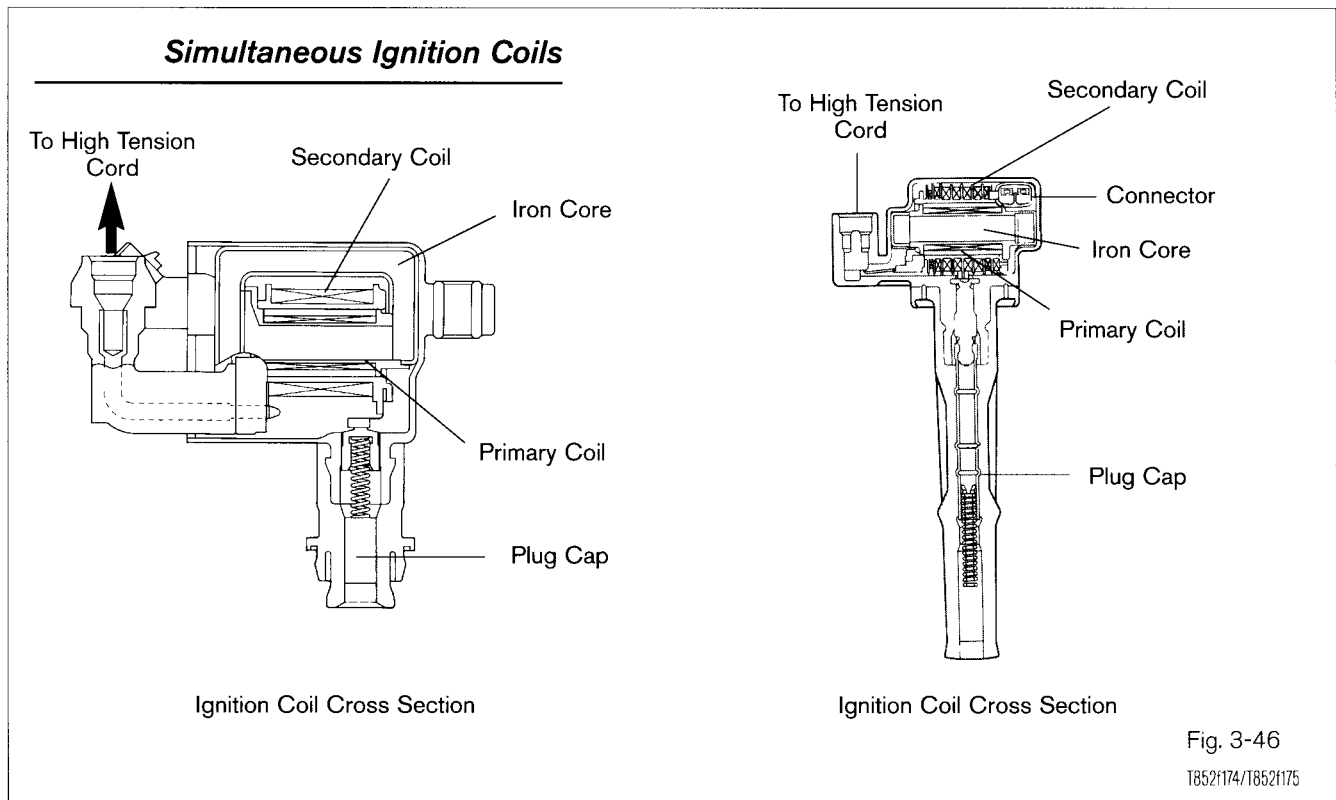

Fig. 3-45

T8521172/T8521173

## IGNITION #3 - DISTRIBUTOR AND DISTRIBUTORLESS TYPES



### DIS with Independent Ignition

The DIS with independent ignition has the igniter built into the coil. Typically, there are four wires that make up the primary side of the coil:

- +13.
- IGT signal.
- IGF signal.
- Ground.

The ECM is able to distinguish which coil is not operating based on when the IGF signal is received. Since the ECM knows when each cylinder needs to be ignited, it knows from which coil to expect the IGF signal.

The major advantages of DIS with independent ignition are greater reliability and less chance of cylinder misfire.

# IGNITION #3 - DISTRIBUTOR AND DISTRIBUTORLESS TYPES

## V-6 1MZ-FE with DIS

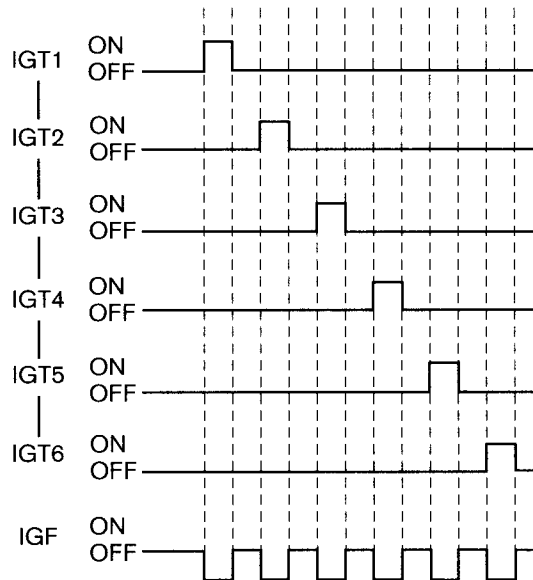
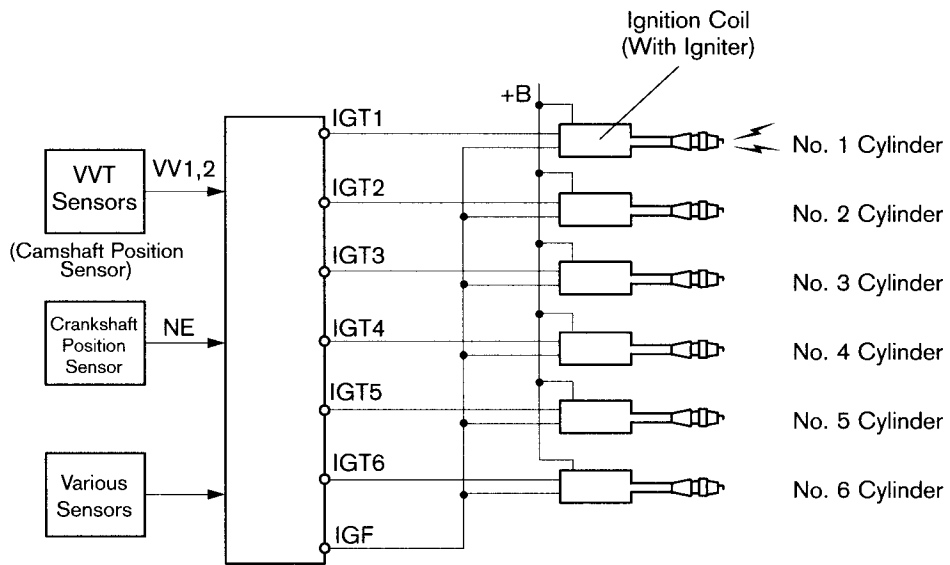

Fig. 3-47

T852176/T852166

# IGNITION #3 - DISTRIBUTOR AND DISTRIBUTORLESS TYPES

## Ignition Coil with Integrated Igniter

This style is used on DIS with independent ignition.

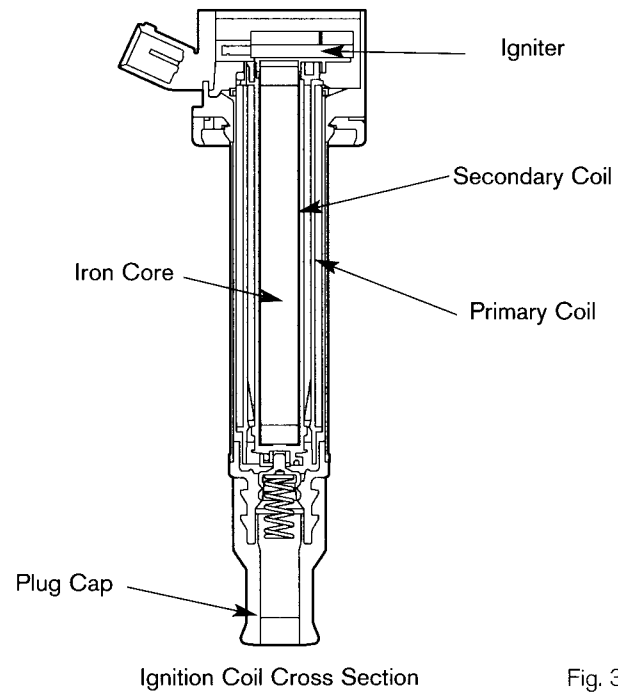

Ignition Coil Cross Section

Fig. 3-48

T8521171

## V-8 with DIS

Each coil is controlled by the IGT signal.

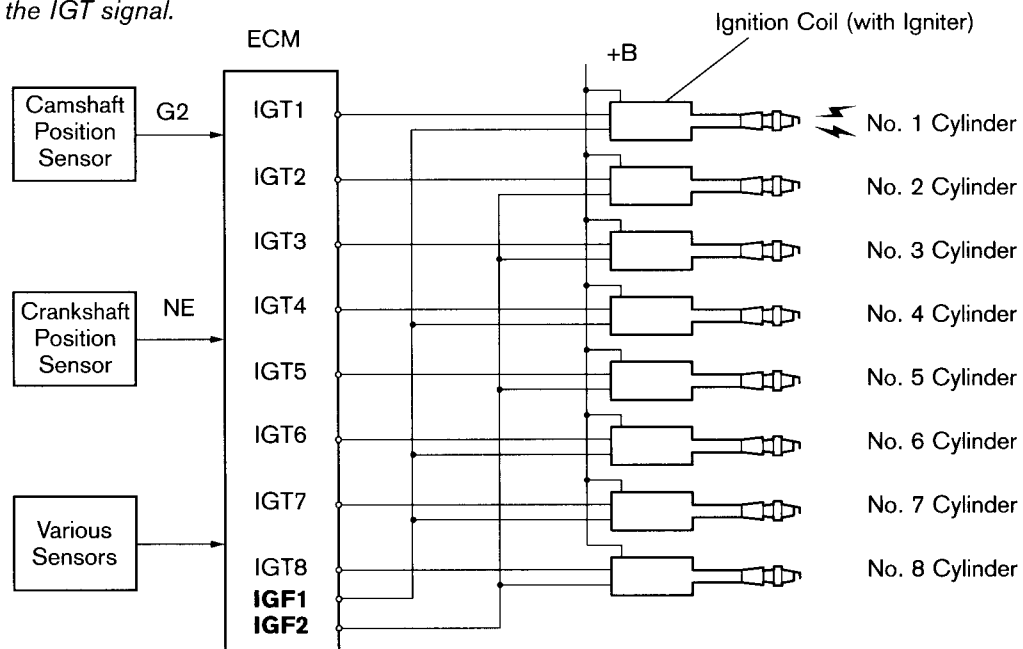
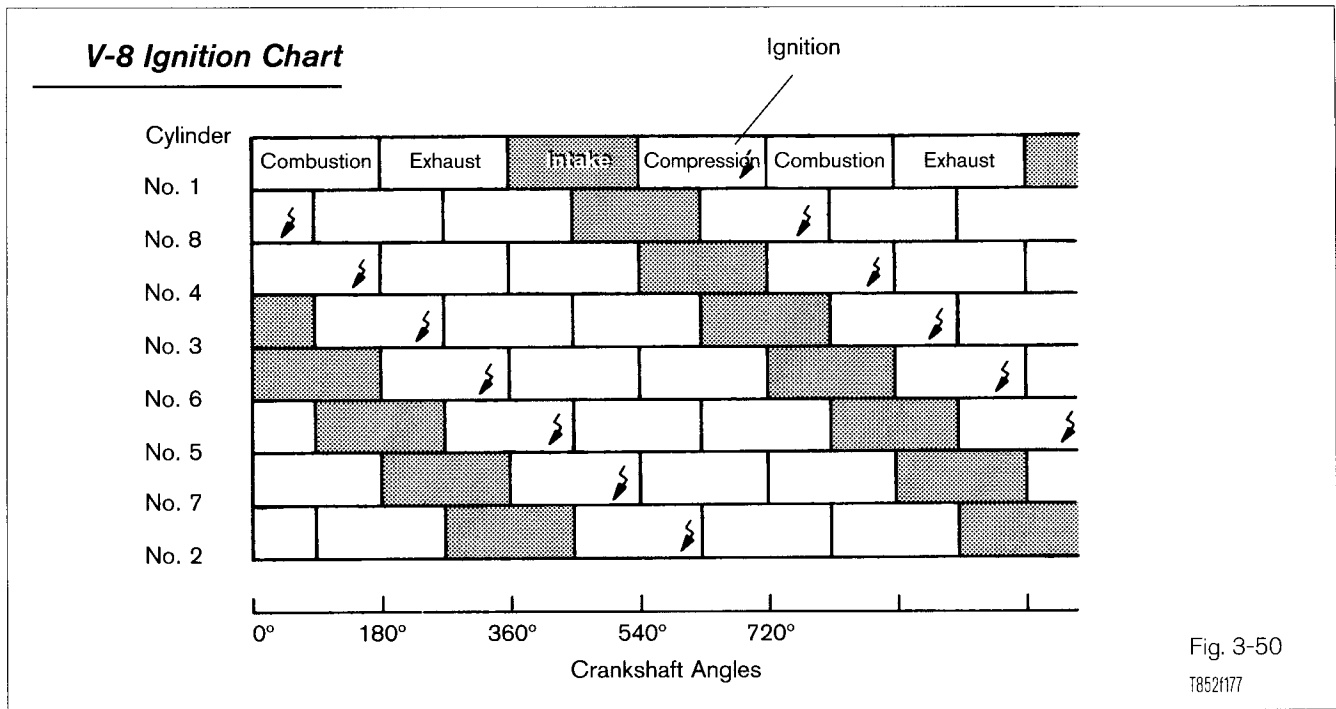

Fig. 3-49

T8521138



## IGNITION #3 - DISTRIBUTOR AND DISTRIBUTORLESS TYPES



### Ignition Advance Service

Though the Diagnostic Tester shows the computed ignition, advance, using a timing light confirms that advance took place and the timing marks are in the correct position.

With Distributor Ignition Systems, the point at which ignition occurs may vary because the base reference point can be moved. It is critical that the base reference point be set to factory specifications.

With DLI and DIS, the base reference point is determined by the Crankshaft Position Sensor and rotor, which is non-adjustable.

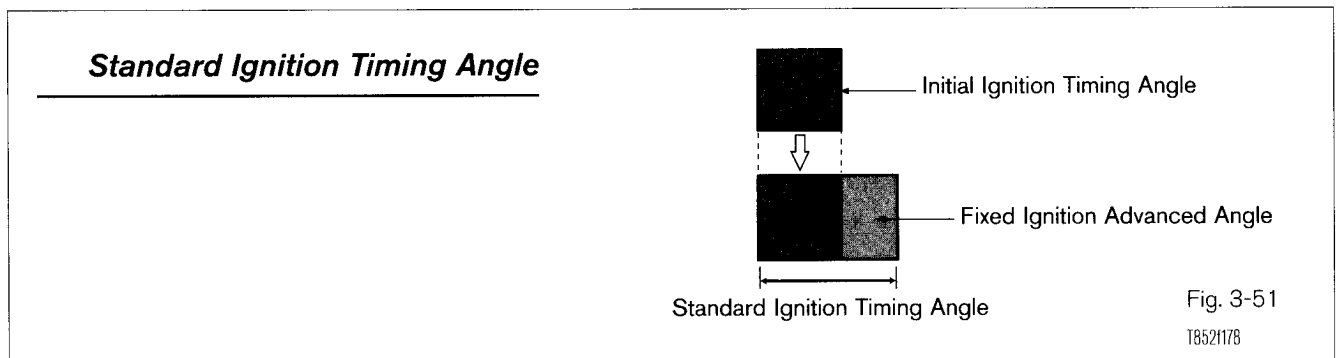

The angle to which the ignition timing is set during ignition timing adjustment is called the "standard ignition timing." It consists of the initial ignition timing, plus a fixed ignition advance angle (a value that is stored in the ECM and output during timing adjustment regardless of the corrections, etc., that are used during normal vehicle operation).

## IGNITION #3 - DISTRIBUTOR AND DISTRIBUTORLESS TYPES

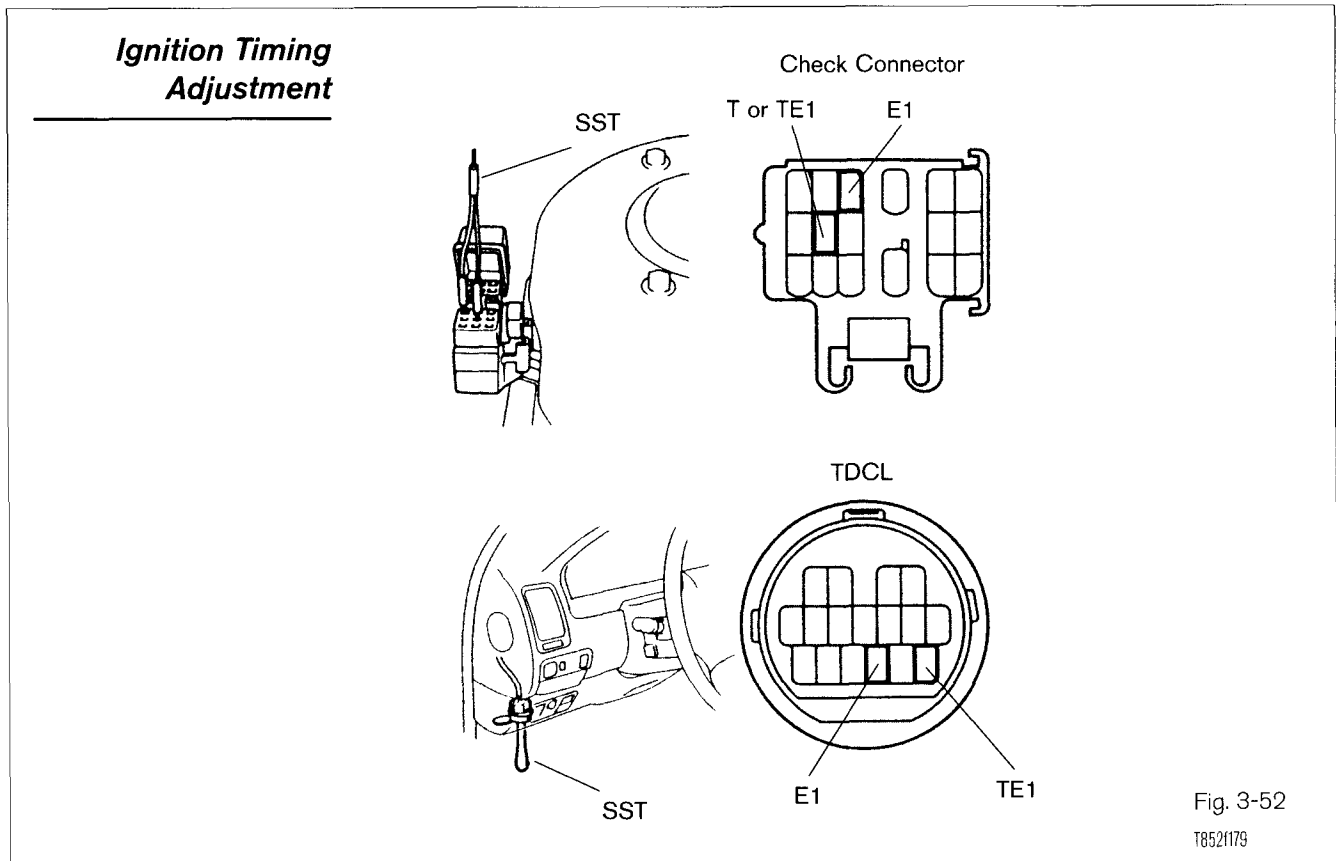

Fig. 3-52

T8521179

Ignition timing adjustment is initiated by connecting terminal T1 (or TE 1) of the check connector or TDCL with terminal E1, with the idle contacts on. This will cause the standard ignition timing signal to be output from the back-up IC in the same way as during after-start ignition control.

The standard ignition timing angle differs depending on the engine model. When tuning up the engine, refer to the repair manual for the relevant engine.

**NOTE:** Even if terminal T1 or TE1 and terminal E1 are connected, the ignition timing will not be fixed at the standard ignition timing unless the idle contacts are on.

Where the G and NE signal generators are in a fixed position (distributorless or direct ignition systems), ignition timing cannot be adjusted.

### Diagnostics

When the igniter is built into the ignition coil, it is not possible to do a resistance check of the primary coil winding. A bad primary winding will have to be determined by checking other functions of the coil and the ignition circuit.

## ***IGNITION #3 - DISTRIBUTOR AND DISTRIBUTORLESS TYPES***

---

DTC 1300 series will set, depending on the engine and type of ignition system, when the ECM does NOT receive the IGF signal. IGF confirms the primary circuit of the ignition system is working. Lack of IGF signal indicates a malfunction in the primary circuit or IGF signal related components.

If the DTC 1300 is set based on IGF, visually check the ignition system and then check for spark. If spark is present, the engine will start then stall when the ECM does not detect IGF (EXCEPT on some engines equipped with DIS with integrated igniter). In addition, when spark is present this confirms the secondary and primary circuits are good. The problem is most likely with the IGF circuitry.

## ***IGNITION #3 - DISTRIBUTOR AND DISTRIBUTORLESS TYPES***

---

### **ASSIGNMENT**

**NAME:** \_\_\_\_\_

1. Explain in the difference between Independent (Direct) and Simultaneous (Waste Spark) Ignition systems: (include the number of coils used in each)
2. Explain in detail Simultaneous (Waste Spark) Ignition system operation:
3. Draw a basic 4 cylinder Simultaneous (Waste Spark) Ignition circuit below:
4. Explain in detail Independent (Direct) Ignition system operation:
5. Draw a basic 4 cylinder Independant (Direct) Ignition circuit below: