

ANALOG VS. DIGITAL METERS

Ultimately, your diagnosis of vehicle electrical system problems will come down to using a voltmeter, ammeter, or ohmmeter to pinpoint the exact location of the problem. There are two types of each meter—**analog and digital.**

Analog meters use a needle and calibrated scale to indicate values.

Digital meters display those values on a digital display.

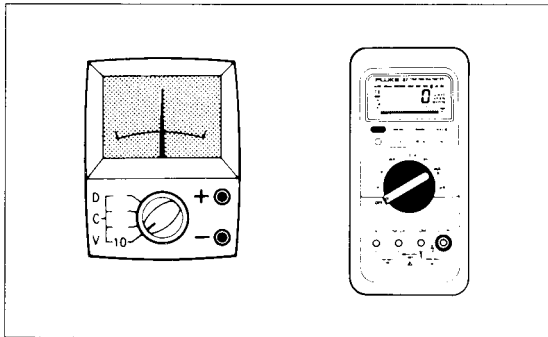

This chapter will help you understand how these meters work as well as the advantages and disadvantages of each.

Before using a meter, read the manufacturer's operating instructions. Reading analog meters usually requires simple mental calculations. For example, a meter might have three voltage ranges: 4.0 V, 20 V and 40 V, but only two scales: 4.0 V and 20 V. In order to use the 40 V range, you need to multiply the needle reading on the 4.0 V scale by 10 (or for that matter, the 20 V scale by 2).

Digital meters are usually simpler to read and many will adjust to the proper range required for the circuit or device they are

connected to. These meters are known as auto-ranging meters. Other digital meters require the operator to select the proper range. In any case it is important to learn the symbols used in a digital readout so you can interpret the reading. The electrical units of measure symbols are:

M for mega or million

K for kilo or thousand

m for milli or one-thousandth

u for micro or one-millionth

The three types of meters—**voltmeters, ammeters and ohmmeters**—connect to the circuits or devices in different ways. This is necessary to get accurate measurements and to prevent damage to the meters.

VOLTMETERS— ANALOG AND DIGITAL

Voltmeters measure voltage or voltage drop in a circuit. Voltage drop can be used to locate excessive resistance in the circuit which could cause poor performance or improper operation. Lack of voltage at a given point may indicate an open circuit or ground. On the other hand, low voltage or high voltage drop, may indicate a high resistance problem like a poor connection.

Voltmeters must be connected in parallel with the device or circuit so that the meter can tap off a small amount of current. That is, the positive or red lead is connected to the circuit closest to the positive side of the battery. The negative or black lead is connected to ground or the negative side of the circuit. If a voltmeter is connected in series, its high resistance would reduce circuit current and cause a false reading.

Because voltmeters are always hooked to a circuit in parallel, they become part of the circuit and reduce the total resistance of the circuit. If a voltmeter has a resistance that is too low in comparison to the circuit, it will give a false measurement. The false reading is due to the meter changing the circuit by lowering the resistance, which increases

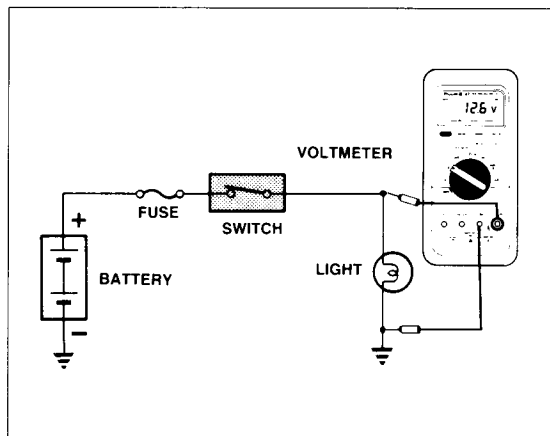

the current flow in the circuit. The effect a voltmeter has on the circuit to which it is attached is sometimes referred to as "loading effect" of the meter. The loading effect a voltmeter has on a circuit is determined by the total resistance of the circuit in relation to the impedance of the voltmeter.

Every voltmeter has an impedance, which is the meter's internal resistance. The impedance of a conventional analog voltmeter is expressed in "ohms per volt." The amount of resistance an analog voltmeter represents to the circuit changes in relation to the scale on which it is placed. Digital voltmeters, on the other hand, have a fixed impedance which does not change from scale to scale and is usually 10 M ohms or more.

Impedance is the biggest difference between analog and digital voltmeters. Since most digital voltmeters have 50 times more impedance than analog voltmeters, digital meters are more accurate when measuring voltage in high resistance circuits.

For example, if you are using a low impedance (20,000 ohms per volt) analog meter on the 20 volt scale (the voltmeter represents 400,000 ohms resistance to the circuit) to measure voltage drop across a 1,000,000 ohm component in a circuit, two and a half times as much current is flowing through the meter than through the component. You are no longer measuring just that component, but the component plus your meter, giving you a false reading of the actual voltage drop across the component. This situation might lead you to believe the voltage at the component is low or that there is high resistance somewhere in the circuit or that the component is defective when it is just the meter you are using.

If you use a digital meter with 10 million ohms of impedance to test the same component, only 1/10 of the current will flow through the meter, which means it has very little effect on the circuit being measured.

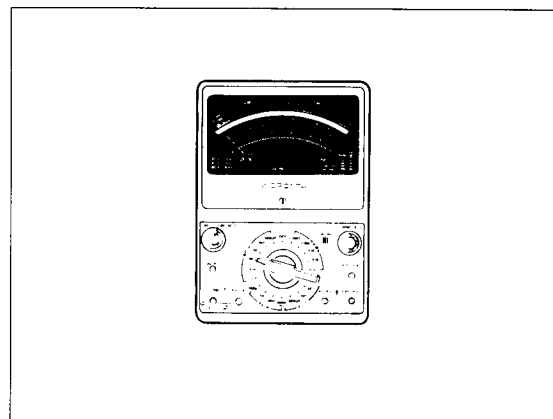

AMMETERS— ANALOG AND DIGITAL

Ammeters measure amperage, or current flow, in a circuit, and provide information on current draw as well as circuit continuity. High current flow indicates a short circuit, unintentional ground or a defective component. Some type of defect has lowered the circuit resistance. Low current flow may indicate high resistance or a poor connection in the circuit or a discharged battery. No current indicates an open circuit or loss of power.

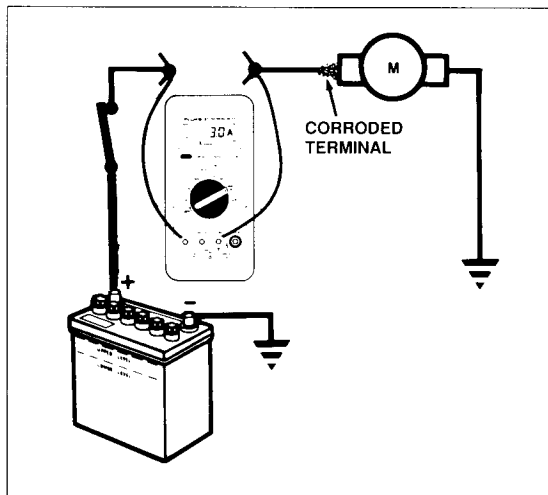

Ammeters must always be connected in series with the circuit, never in parallel. That is, all the circuit current must flow through the meter. It is connected by attaching the positive lead to the positive or battery side of the circuit, and the negative lead to negative or ground side of the circuit, as shown.

CAUTION: These meters have extremely low internal resistance. If connected in parallel, the current running through the parallel branch created by the meter might be high enough to damage the meter along with the circuit the meter is connected to. Also, since all the current will flow through the ammeter when it is connected be sure that the circuit current will not exceed the maximum rating of the meter.

There is not a great difference between analog and digital ammeters. Digital meters are often capable of measuring smaller currents, all the way down to microamps. They are easier to use because they give a specific value, eliminating the need to interpret the analog meter's needle on its scale. Generally speaking, most digital ammeters are combined with a voltmeter.

OHMMETERS— ANALOG AND DIGITAL

An ohmmeter is powered by an internal battery that applies a small voltage to a circuit or component and measures how much current flows through the circuit or component. It then displays the result as resistance. Ohmmeters are used for

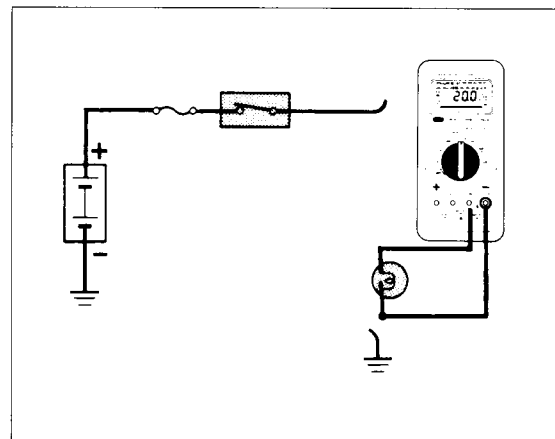

checking continuity and for measuring the resistance of components. Zero resistance indicates a short while infinite resistance indicates an open in a circuit or device. A reading higher than the specification indicates a faulty component or a high resistance problem such as burnt contacts, corroded terminals or loose connections.

Ohmmeters, because they are self-powered, must never be connected to a powered circuit as this may blow a fuse in the meter and damage its battery. Unless the circuit being measured contains a diode, polarity (attaching the leads in a particular order) is inconsequential.

An analog ohmmeter should be calibrated regularly by connecting the two leads together and zeroing the meter with the adjust knob. This compensates for changes in the state of charge of the internal battery.

CAUTION: Analog ohmmeters may apply a higher voltage to a circuit than a digital ohmmeter, causing damage to solid state components.

Use analog ohmmeters with care. Digital meters, on the other hand, apply less voltage to a circuit, so damage is less likely.

Analog meters can also bias, or turn on, semi-conductors and change the circuit by allowing current to flow to other portions of the circuit.

Most digital meters have a low voltage setting which will not bias semi-conductors and a higher voltage setting for testing semiconductors. The information displayed on a digital meter in the diode test function differs from one meter brand to another. Some digital meters will display a value which represents the perceived resistance of the diode in forward bias. Other meters will display the forward bias voltage drop of the diode.

Digital ohmmeters do have one limitation. Due to the small amount of current they pass through the device being tested, they cannot check some semiconductors in circuits, such as a clamping diode on a relay coil.

Many analog ohmmeters will, when switched to the ohm function, reverse the polarity of the test leads. In other words, the red lead may become negative and the black lead may become positive. The meter will function properly as long as you are aware of this and reverse the leads. This is especially important when working with diodes or transistors which are polarity sensitive and only allow current to flow from the positive to the negative end. To check for polarity reversal, set the ohmmeter in ohm function and connect its leads to the leads of a voltmeter (red to red, black to black). If the voltmeter shows a negative value, that particular ohmmeter reverses polarity in ohm function. Most digital meters do not reverse polarity.

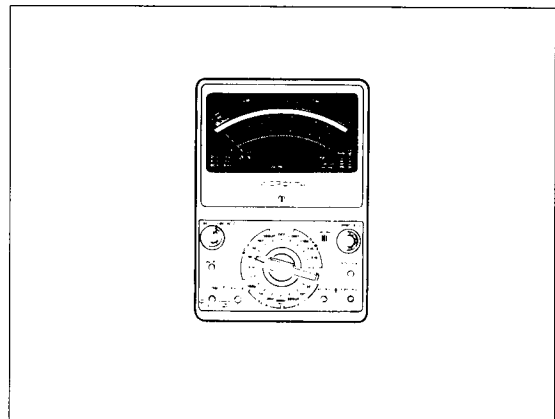

You should note that ohmmeters do little good in low resistance, high current-carrying circuits such as starters. They cannot find points of high resistance because they only use a small amount of current from their internal batteries. In a large conductor (such as a battery cable), this current meets little resistance. A voltage drop test during circuit operation is much more effective at locating points of high resistance in this type of circuit.

Taken with permission from the
Toyota Advanced Electrical Course#672,

ANALOG AND DIGITAL METERS

ASSIGNMENT

NAME: _____

- 1. Explain how reading an Analog meter differs from a Digital meter.**
- 2. Explain the following electrical units of measure symbols (M, K, m, u).**
- 3. List three types of meters.**
- 4. Describe how voltmeters are connected to a circuit.**
- 5. Explain how “meter loading” affects the circuit.**
- 6. Describe “meter impedance” and how it effects a circuit?**
- 7. List the fixed impedance value of a digital voltmeter.**
- 8. Explain how the impedance of a digital meter differs from an analog meter.**
- 9. Describe how ammeters are connected to a circuit.**
- 10. Explain how analog ohmmeters differ from digital ohmmeters in setup.**
- 11. Explain what precautions one should take while connecting an ohmmeter to a circuit.**