

MISSING 20, 25 30 UNWARD

1

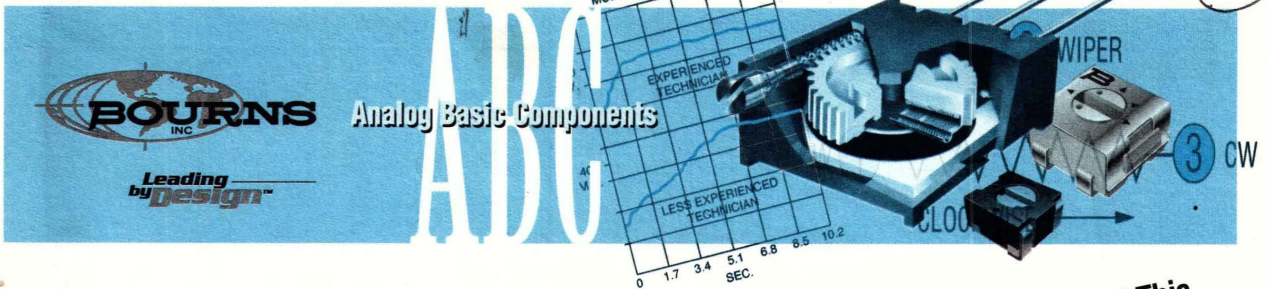

Until that far-off time when electronic circuits are perfect, you'll need to include variable resistors in your designs.

You Won't Find This **FREE** Info in Any Catalog!

During each of the next 12 months, Bourns and EDN will bring you easy-to-read excerpts from our popular "Trimmer Primer" series. For many of you, the Trimmer ABC Program will be a refresher course; for others, perhaps newer to the electronic design field, it will include information on analog components you can really use.

FRMD

If you wish to participate fully in the program, we will send you a 3-ring binder with index tabs to house your information, technical articles and white papers. See the reverse side for ordering information.

THE BASICS

A TRIMMING POTENTIOMETER (AKA TRIMMER) IS MOST OFTEN INCLUDED IN A CIRCUIT FOR EASY "TWEAKING" - TO CORRECT FOR VARIATIONS IN OTHER CIRCUIT COMPONENTS, OR FOR CHANGES DUE TO AGING.

IT'S DESIGNED SO YOU CAN VARY ITS RESISTANCE, OR USE IT AS A VOLTAGE DIVIDER FOR ADJUSTING VOLTAGE.

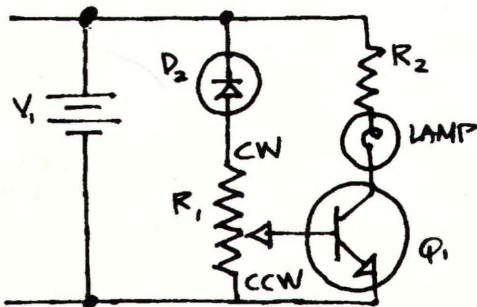

ADJUSTMENT FOR CIRCUIT VOLTAGES - (VOLTAGE DIVIDER MODE)

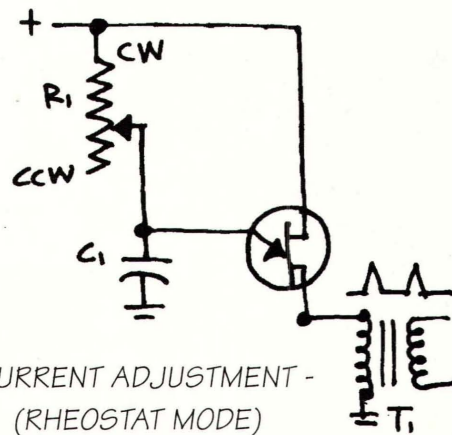

CURRENT ADJUSTMENT - (RHEOSTAT MODE)

ENGINEERS WITH IMAGINATION HAVE USED TRIMMERS TO SOLVE INNUMERABLE DESIGN PROBLEMS. HERE ARE A FEW EXAMPLES THAT SUGGEST THE WIDE RANGE OF POSSIBILITIES:

TYPE OF CIRCUIT	EXAMPLES OF USE
POWER SUPPLIES	<ul style="list-style-type: none"> • OUTPUT VOLTAGE ADJUSTMENT • CURRENT LIMIT ADJUSTMENT
OP AMP	<ul style="list-style-type: none"> • OFFSET ADJUSTMENT • GAIN ADJUSTMENT
DIGITAL CIRCUITS*	<ul style="list-style-type: none"> • TIME DELAY IN A MONOSTABLE • ADJUSTMENT OF OFFSET ERRORS IN PHOTOCELL CIRCUIT
INSTRUMENTS	<ul style="list-style-type: none"> • CALIBRATION OF DIGITAL VOLT METERS • ADJUSTMENT OF TRIGGER, TIMING AND OTHER CIRCUITS IN GENERATORS AND OSCILLOSCOPES

* YES, TRIMMERS CAN BE USED IN DIGITAL CIRCUITS!

90% OF ALL CIRCUITS USING TRIMMING POTENTIOMETERS BOIL DOWN TO ABOUT TWO DOZEN BASIC TYPES, SUCH AS:

I. AMPLIFIER	II. TIMER/OSCILLATOR	III. REGULATOR	IV. CONVERSION
A. AUDIO	A. ONE SHOT	A. VOLTAGE	D/A, A/D
B. RF	B. FREE RUNNING	B. CURRENT	V/F, F/V
C. OPERATIONAL			

TYPICAL MULTITURN APPLICATIONS:

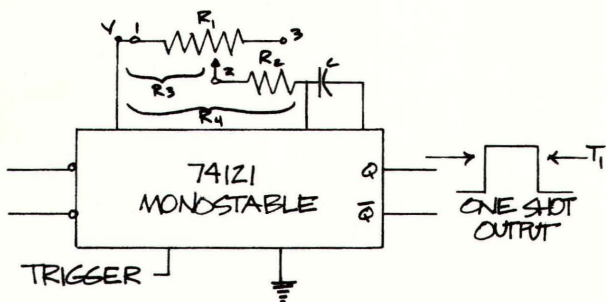
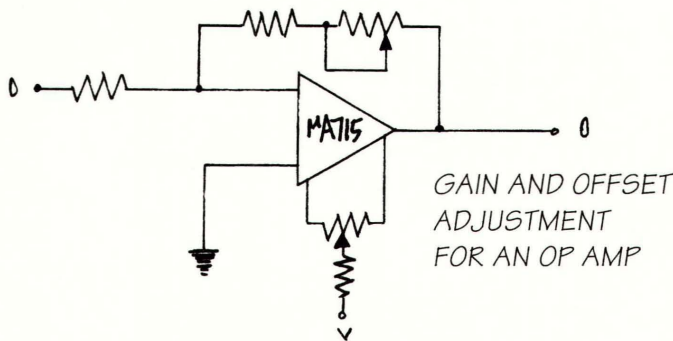

TIMING ADJUSTMENT OF MONOSTABLE

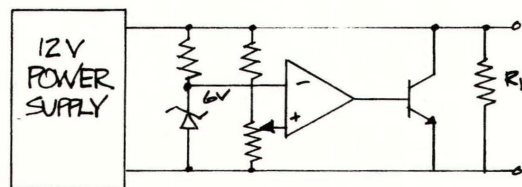

SHUNT REGULATOR

Here's How to Participate:

e-mail: techweb@bourns.com • FAX: (909) 781-5273 (North America); +41- 41 7685510 (Europe)
or the Bourns Web Site: www.bourns.com

BOURNS INC. **Leading by Design™**

ABC Analog Basic Components

MULTITURN SETTABILITY

EXPERIENCED TECHNICIAN

LESS EXPERIENCED TECHNICIAN

0 1.7 3.4 5.1 6.8 8.5 10.2 SEC.

WIPER

3 CW

TYPES OF TRIMMERS

TRIMMERS CONSIST OF:

1. A RESISTIVE ELEMENT
2. TWO END TERMINALS
3. A MOVEABLE CONTACT (WIPER)
4. A CONTACT ACTUATOR (SHAFT, ADJUSTMENT SCREW OR ROTOR)

You Won't Find This
FREE
Info in Any Catalog!

1. LEADSCREW ACTUATED

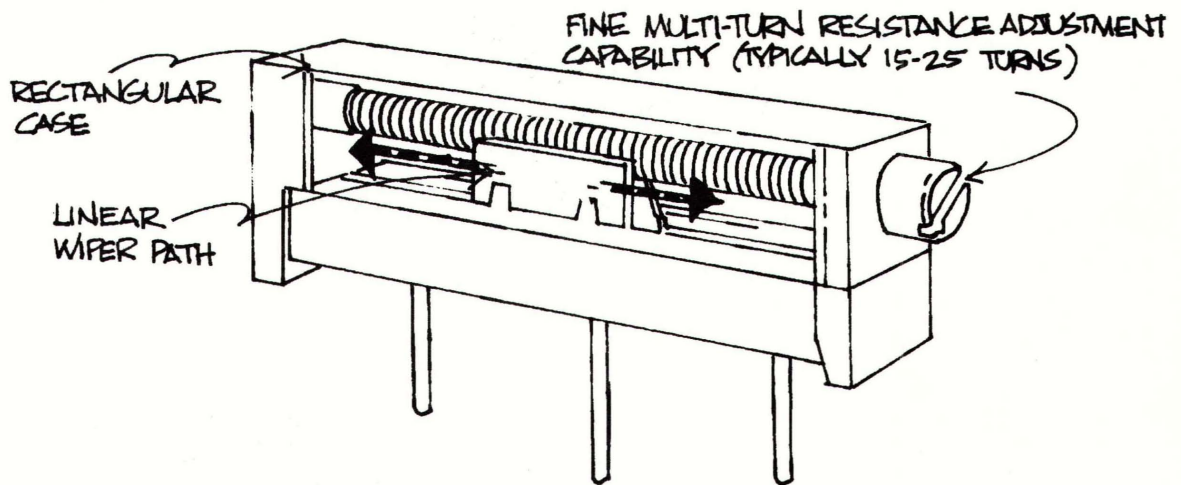

2. WORM GEAR ACTUATED

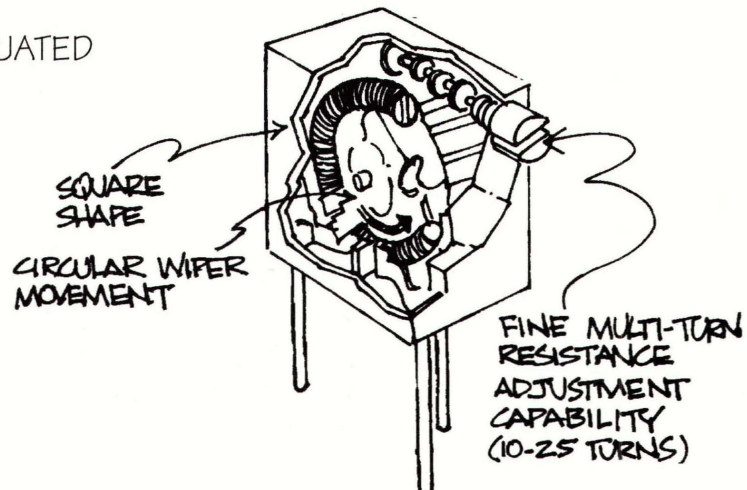

3. SINGLE-TURN

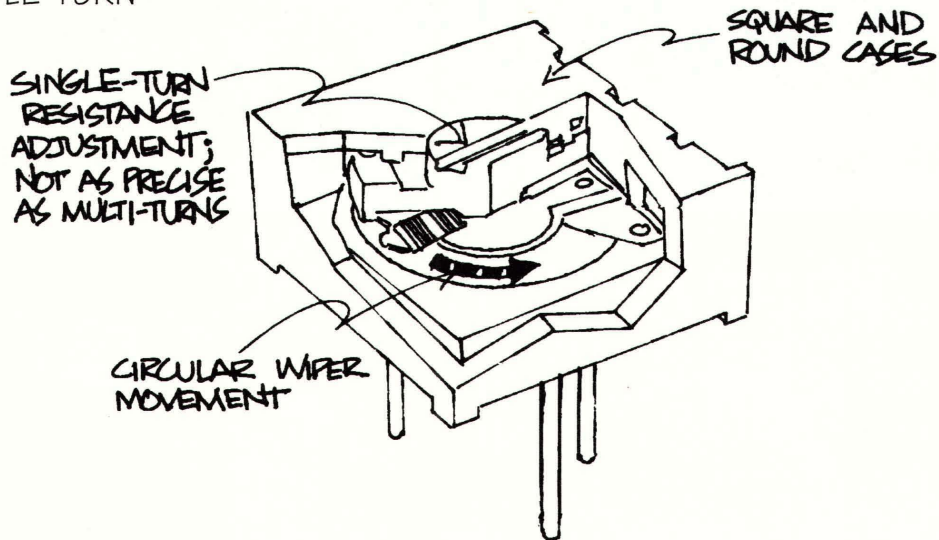

4. SURFACE MOUNT

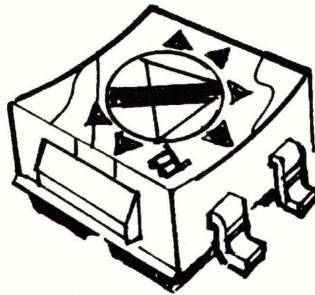

5. CENTER TAP

CENTER TAP DIVIDES THE POTENTIOMETER INTO TWO SEPARATE, INDEPENDENT UNITS. ESPECIALLY USEFUL IN OP-AMP APPLICATIONS.

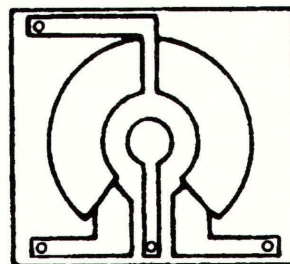

Here's How to Participate:

Starting in May 1998, EDN will publish excerpts from Bourns' popular "Trimmer Primer" series each month. To participate fully in the program, Bourns will send you a 3-ring binder to house your information, technical articles, white papers and more. To get started, order your binder or any materials you may not have received, contact us via:

e-mail: techweb@bourns.com • FAX: (909) 781-5273 (North America); +41- 41 7685510 (Europe)
or the Bourns Web Site: www.bourns.com

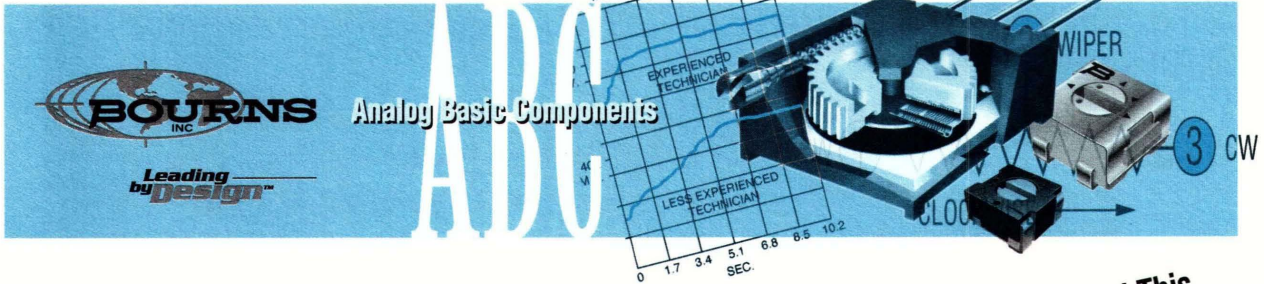

SINGLE-TURN OR MULTITURN TRIMMERS?

You Won't Find This **FREE** Info in Any Catalog!

	SINGLE-TURN	MULTITURN
SETTING ACCURACY		✓
SPEED ADJUSTING: TO ACCURATE SETTING		✓
TO APPROXIMATE SETTING	✓	

SETTABILITY – SINGLE-TURN VS. MULTITURN —
TECHNICIANS OR PRODUCTION WORKERS TYPICALLY ADJUST A MULTITURN TO A DESIRED SETTING FASTER THAN A SINGLE-TURN.

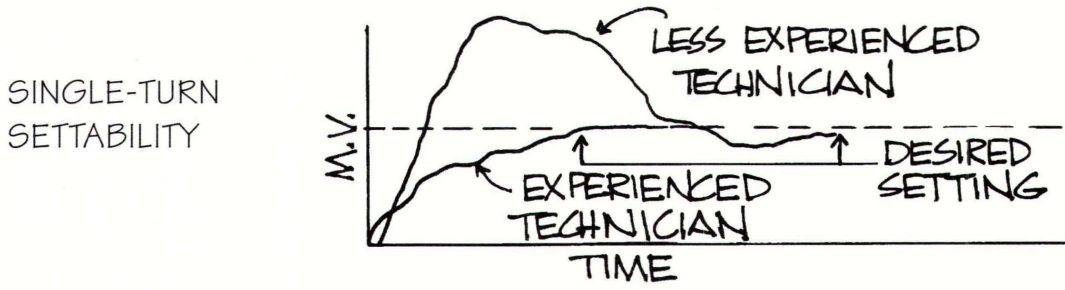
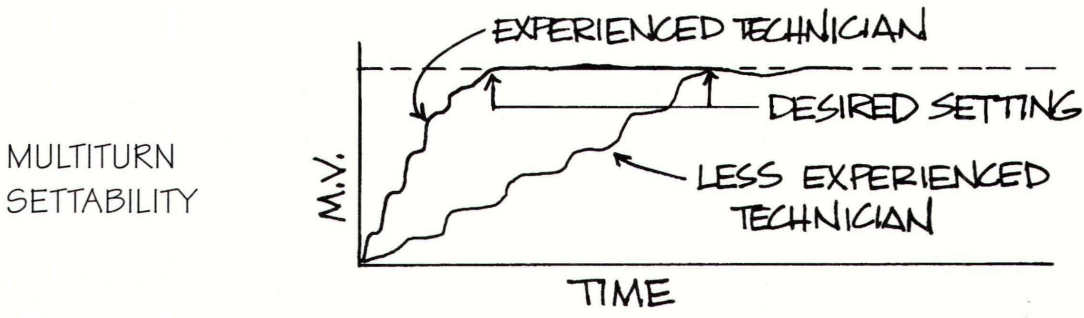

APPLICATIONS THAT USUALLY FAVOR THE COST-EFFECTIVE USE OF MULTITURN TRIMMERS:

1. OP AMP ZERO ADJUST – THE MULTITURN ADVANTAGE OVER SINGLE-TURNS IN THE APPLICATION IS A SHORTER ADJUSTMENT TIME TO AN ACCURATE SETTING.
2. VOLTAGE REGULATOR ADJUST – SINGLE-TURN TRIMMERS USED IN THIS APPLICATION REQUIRE TWO FIXED RESISTORS. THE EXTENDED RANGE FEATURE OF A MULTITURN PROVIDES VOLTAGE DROPPING AND FINE ADJUST IN ONE UNIT.

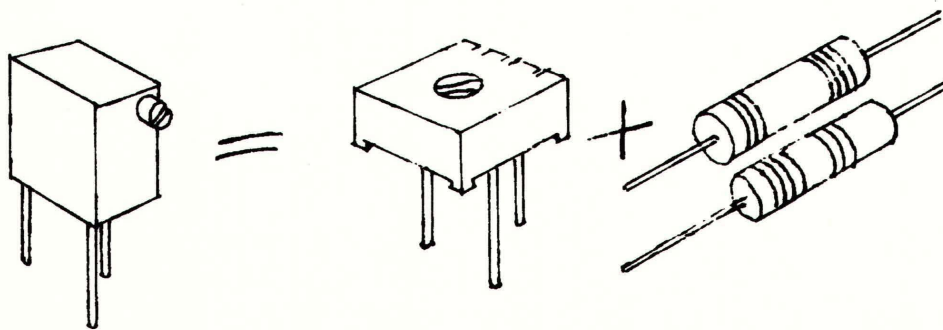

MULTITURN TRIMMERS SAVE VALUABLE BOARD SPACE AND CUT COMPONENT INSTALLATION COSTS.

3. OSCILLATOR FREQUENCY ADJUSTMENT – MULTITURNS GIVE ACCURATE ADJUSTMENT, QUICKLY – EVEN WHEN DONE BY AN INEXPERIENCED OPERATOR.

NOTE: MULTITURNS AREN'T ALWAYS THE ANSWER. APPLICATIONS SUCH AS DATA-INPUT FOR DIGITAL EQUIPMENT, WHERE THE LEVEL OF ACCURACY IS NOT CRITICAL, ARE PERFECT FOR SINGLE-TURN TRIMMERS.

Here's How to Participate:

Starting in May 1998, EDN will publish excerpts from Bourns' popular "Trimmer Primer" series each month. To participate fully in the program, Bourns will send you a 3-ring binder to house your information, technical articles, white papers and more. To get started, order your binder or any materials you may not have received, contact us via:

*e-mail: techweb@bourns.com • FAX: (909) 781-5273 (North America); +41- 41 7685510 (Europe)
or the Bourns Web Site: www.bourns.com*

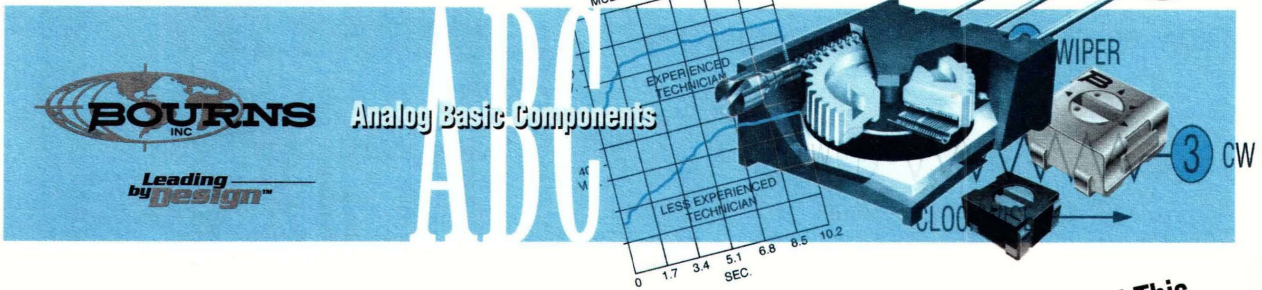

CERMET VS. WIREWOUND TRIMMERS

You Won't Find This
FREE
Info in Any Catalog!

THE RESISTIVE ELEMENT OF A TRIMMER MAY BE MADE OF A NUMBER OF MATERIALS. THE TWO MOST COMMON ARE A CERAMIC (CONDUCTIVE GLASS)/METALLIC OXIDE COMBINATION CALLED "CERMET," AND WIREWOUND ON A COPPER MANDREL. (CARBON, ONCE WIDELY USED, IS LEAST COMMON FOR INDUSTRIAL APPLICATIONS.)

CERMET ELEMENTS (LINEAR WIPER PATH)

- HIGH RESOLUTION (SMALL INCREMENTAL CHANGES IN OUTPUT WITH WIPER TRAVEL)
- LOW TERMINATION RESISTANCE

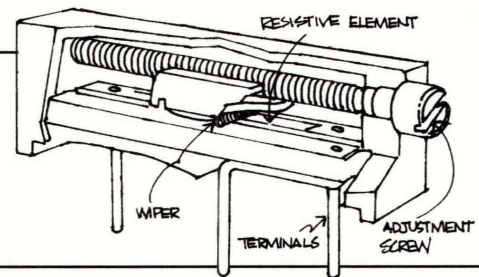

WIREWOUND ELEMENTS (CIRCULAR WIPER PATH)

- LONG CYCLING LIFE (WEAR)
- CONFORMITY OVER LIFE; I.E., OUTPUT VS. WIPER POSITION
- LOW EQUIVALENT NOISE RESISTANCE

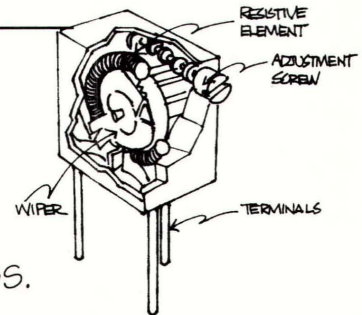

CERMET AND WIREWOUND ELEMENTS ARE PACKAGED IN RECTANGULAR, SQUARE AND ROUND CASES OR HOUSINGS.

WHICH ONE IS BETTER?

THE CHOICE BETWEEN CERMET AND WIREWOUND DEPENDS ON YOUR PARTICULAR REQUIREMENTS. THE CHECK MARK SHOWS WHICH ONE PERFORMS BETTER IN EACH CHARACTERISTIC.

	CERMET	WIREWOUND
RESISTANCE RANGE	10Ω - 5MΩ	10Ω - 50KΩ
LOW TEMPERATURE COEFFICIENT		✓
HIGH POWER DISSIPATION		✓
TIGHT RESISTANCE TOLERANCE		✓
RESISTANCE STABILITY		✓
SETTING ACCURACY	✓	
LOW REACTANCE IN HIGH FREQUENCY CIRCUITS	✓	
LOWER COST	✓	
SMALLER SIZES	✓	
NOISE (DURING ADJUSTMENT)		✓

HOW TO SELECT THE RIGHT TRIMMER

CONSIDER THE FOLLOWING APPLICATION AND SELECTION FACTORS FOR THE BEST COST/PERFORMANCE CIRCUIT DESIGN:

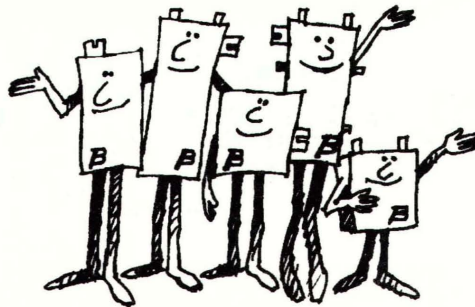

1. ELECTRICAL PARAMETERS –
 - A. CIRCUIT INTERFACE RESISTANCE VS. TRIMMER RESISTANCE
 - B. CIRCUIT GAIN AND SENSITIVITY VS. TRIMMER RESOLUTION AND ADJUSTABILITY
 - C. CIRCUIT VOLTAGE/CURRENT VS. TRIMMER POWER RATING
 - D. NOISE TOLERANCE LIMIT VS. TRIMMER NOISE SPECIFICATION AND LOCATION IN CIRCUIT

ELECTRICAL ABUSE AND MISUSE OF TRIMMERS ARE COMMON. CONTACTING A BOURNS ENGINEER AT THE START OF A CIRCUIT DESIGN CAN HELP REDUCE POTENTIAL PROBLEMS.



2. MECHANICAL REQUIREMENTS – ANSWER THESE QUESTIONS:
 - A. WHAT CASE STYLE AND PIN CONFIGURATIONS ARE NEEDED?
 - B. TOP OR SIDE ADJUSTMENT?
 - C. IS A CUSTOM UNIT REQUIRED?
3. THE ENVIRONMENT – BE SURE THE TRIMMER'S TEMPERATURE COEFFICIENT AND OPERATING TEMPERATURE MATCH THE ENVIRONMENT OF YOUR SYSTEM.



Here's How to Participate:

Starting in May 1998, EDN will publish excerpts from Bourns' popular "Trimmer Primer" series each month. To participate fully in the program, Bourns will send you a 3-ring binder to house your information, technical articles, white papers and more. To get started, order your binder or any materials you may not have received, contact us via:

*e-mail: techweb@bourns.com • FAX: (909) 781-5273 (North America); +41- 41 7685510 (Europe)
or the Bourns Web Site: www.bourns.com*



HOW TO SELECT THE RIGHT TRIMMER

(Continued from previous issue)

You Won't Find This
FREE
Info in Any Catalog!

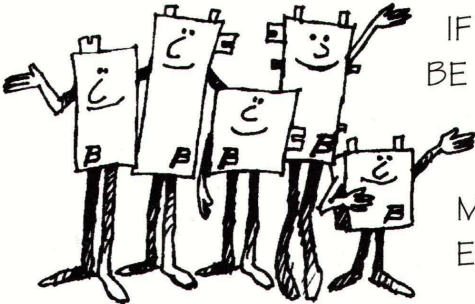

IF THE CIRCUIT BOARD WILL BE WASHED, CHECK OUT THE SEALING DESIGN AND INTEGRITY OF THE TRIMMER. PROPER TRIMMER SEALING IS A MUST IN A HUMID OR DIRTY OPERATING ENVIRONMENT.

MANY UNITS INCORPORATE SELF-SEALING CHEVRONS OR "O-RINGS" TO HELP PROTECT AGAINST HUMIDITY AND BOARDWASHING.

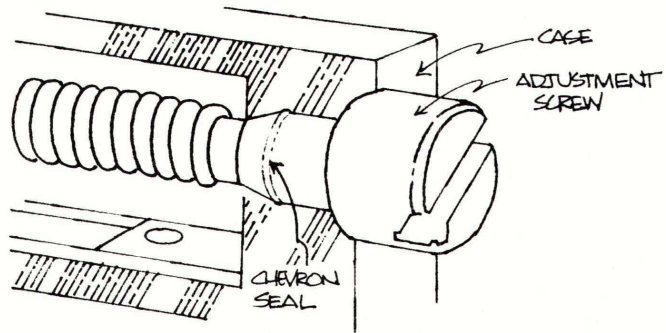

EXCESS VIBRATION AND SHOCK CAN DAMAGE A TRIMMER. SO MAKE SURE THE CONSTRUCTION CAN HANDLE ANY UNIQUE REQUIREMENTS.

- DON'T FORGET HUMAN INTERFACE!
 - A. THE ADJUSTMENT SCREW MUST BE IN AN ACCESSIBLE LOCATION ON THE CIRCUIT BOARD.
 - B. SELECT THE TRIMMER BEST SUITED TO THE OPERATOR'S SKILL AND ADJUSTMENT TIME REQUIREMENTS. REMEMBER, NOT EVERYONE CAN MAKE FINE ADJUSTMENTS QUICKLY.

MULTITURN TRIMMERS CAN GIVE A FASTER SETTING.

- RELIABILITY – BE SURE TO SPEC TRIMMERS WITH SECURE RESISTIVE ELEMENT TERMINATIONS.

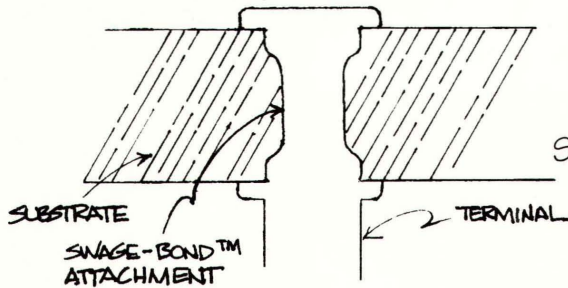

SWAGED PIN ATTACHMENTS ARE DESIGNED FOR LONG-TERM SECURITY AND RELIABILITY.

MAKING YOUR BOSS SMILE: SELECTING A TRIMMER THAT SAVES MONEY.

- OPEN FRAME – YOU CAN SAVE MONEY BY BUYING AN OPEN-FRAME TRIMMER INSTEAD OF A SEALED ONE. BUT BEWARE - IF THE BOARD MUST BE WASHED, OPEN-FRAME UNITS MAY BECOME CONTAMINATED WITH RESIDUE, CREATING AN EXCESSIVE NUMBER OF BOARDS REJECTED AT FINAL INSPECTION OR WHILE IN USE BY YOUR CUSTOMER. A LOW-COST SEALED UNIT MAY BE A LESS EXPENSIVE CHOICE IN THE LONG RUN.
- CONSERVING PC BOARD REAL ESTATE – CONSIDER USING A TRIMMER THAT SITS ON EDGE INSTEAD OF FLAT ON THE BOARD.

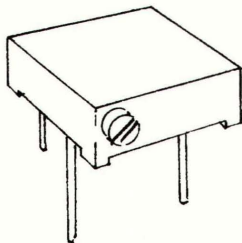

BOURNS MODEL 3296P

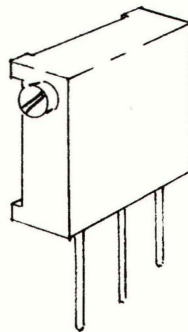

BOURNS MODEL 3296X

Here's How to Participate:

Beginning in May 1998, EDN has been publishing excerpts from Bourns' popular "Trimmer Primer" series each month. To participate fully in the program, Bourns will send you a 3-ring binder to house your information, technical articles, white papers and more. To get started, order your binder or any materials you may not have received, contact us via:

e-mail: techweb@bourns.com • FAX: (909) 781-5273 (North America); +41- 41 7685510 (Europe)
or the Bourns Web Site: www.bourns.com



TRIMMERS FOR SPECIAL REQUIREMENTS

You Won't Find This
FREE
Info in Any Catalog!

HERE ARE A FEW HANDY TIPS ON SPECIAL APPLICATIONS.

✓ OP-AMP ADJUSTMENT –

A CENTER TAP TRIMMER CAN ISOLATE BOTH OP-AMP POWER SUPPLIES TO REDUCE THE NEGATIVE EFFECT OF DRIFT. THIS RESULTS IN A 10X IMPROVEMENT IN VOLTAGE EFFECT ERROR CAUSED BY POWER SUPPLY DRIFT.

SCHEMATIC OF
CENTER TAP TRIMMING
POTENTIOMETER

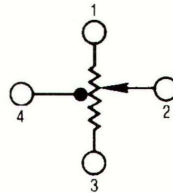

SUGGESTED OFFSET VOLTAGE ADJUSTMENTS:

VOLTAGE
FOLLOWER

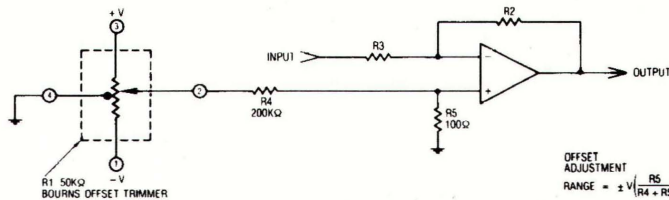
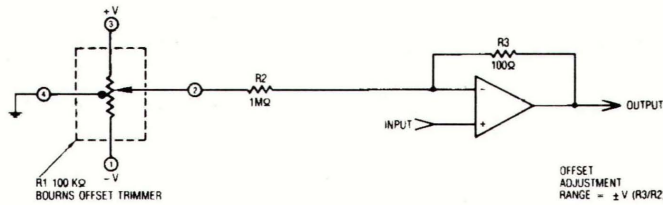

INVERTING
AMPLIFIER

NON-INVERTING
AMPLIFIER

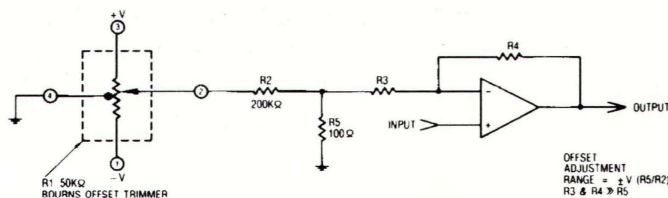

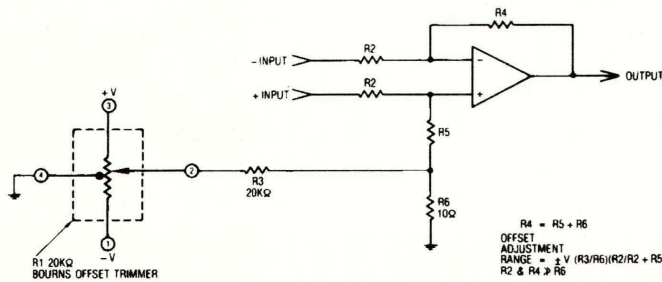

DIFFERENTIAL AMPLIFIER

- COARSE/FINE ADJUSTMENT – TWO TRIMMERS INSTEAD OF ONE CAN PROVIDE AN ADJUSTMENT THAT'S QUICK, EASY AND ACCURATE FOR THE USER.

TWO SINGLE-TURN TRIMMERS IN SERIES

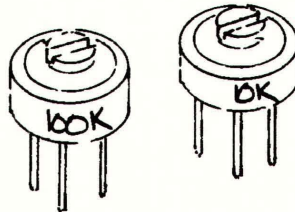

- NON-LINEAR – THE CHANGE IN RESISTANCE FOR A GIVEN CHANGE IN WIPER POSITION IS TYPICALLY USED IN A LINEAR MODE. SPECIAL TRIMMERS CAN BE SUPPLIED THAT PROVIDE LOG-ARITHMIC AND OTHER NON-COMPLEX TAPERS. CONSULT THE SUPPLIER FOR ASSISTANCE. . .

OR, ADD A FIXED RESISTOR BETWEEN THE CENTER TAP AND ONE END OF A CENTER-TAPPED DEVICE TO MAKE YOUR OWN CUSTOM TAPER.

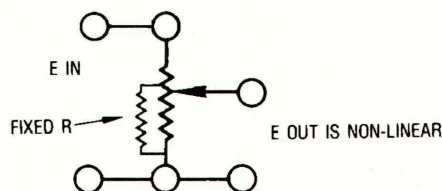

Here's How to Participate:

Beginning in May 1998, EDN has been publishing excerpts from Bourns' popular "Trimmer Primer" series each month. To participate fully in the program, Bourns will send you a 3-ring binder to house your information, technical articles, white papers and more. To get started, order your binder or any materials you may not have received, contact us via:

e-mail: techweb@bourns.com • FAX: (909) 781-5273 (North America); +41- 41 7685510 (Europe) or the Bourns Web Site: www.bourns.com

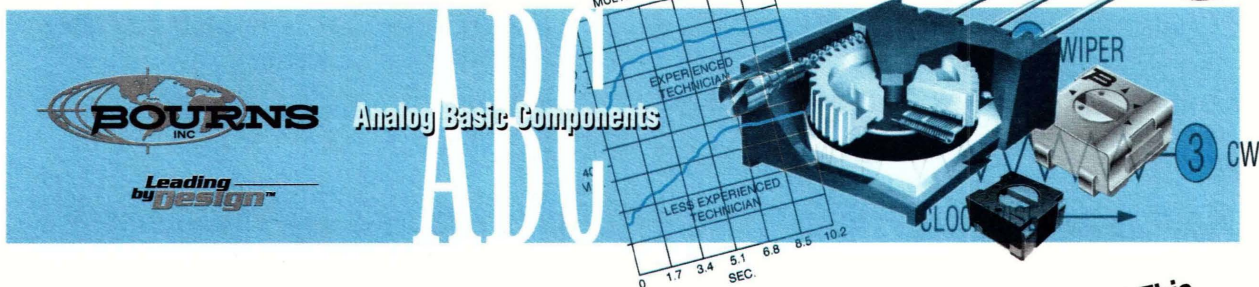

VOLTAGE DIVIDER AND RHEOSTAT MODES

LET'S LOOK AT THE BASIC OPERATING MODES OF A TRIMMER ONE MORE TIME.

You Won't Find This **FREE** Info in Any Catalog!

1. THE VOLTAGE DIVIDER MODE, FROM WHICH THE DEVICE GOT ITS NAME.
2. THE RHEOSTAT MODE, WHERE THE UNIT IS USED AS A VARIABLE RESISTOR TO CONTROL THE FLOW OF CURRENT IN A CIRCUIT.

IN THE VOLTAGE DIVIDER MODE, THE POTENTIOMETER IS CONNECTED AS A THREE-TERMINAL DEVICE, SHOWN IN FIGURE 1. HERE THE POTENTIOMETER IS USED TO PROVIDE AN ADJUSTABLE OUTPUT VOLTAGE (E_o) THAT IS A FRACTIONAL VALUE OF SOME INPUT VOLTAGE (E_i).

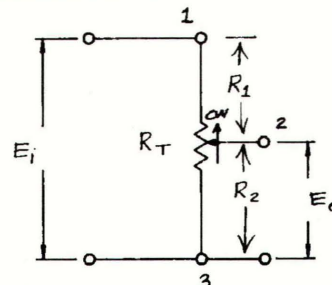

VOLTAGE DIVIDER MODE
FIGURE 1

FOR THE CALCULATION EXAMPLE BELOW, WE'LL CALL THE PORTION OF THE ELEMENT ABOVE THE WIPER CONTACT R_1 . WE'LL CALL R_2 THE PART BELOW THE WIPER CONTACT. THIS WAY WE CAN TREAT THE DEVICE AS A SIMPLE FIXED VOLTAGE DIVIDER.

USING OHM'S LAW, FOR ANY GIVEN WIPER SETTING, WE CAN DETERMINE THAT THE OUTPUT VOLTAGE (E_o) IS RELATED TO THE INPUT VOLTAGE (E_i) BY THE RELATIONSHIP:

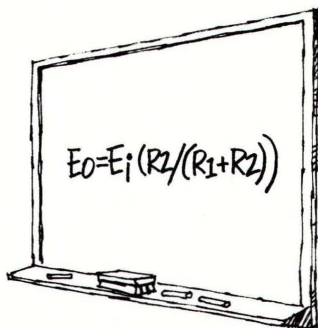

THIS RELATIONSHIP IS, OF COURSE, EXACT ONLY UNDER IDEAL CONDITIONS. FOR INSTANCE, IF WE ADD A LOAD RESISTANCE FROM THE WIPER TERMINAL TO GROUND, THE ABOVE EQUATION WOULD HAVE TO BE MODIFIED TO REFLECT THE CHANGE.

HOWEVER, FOR PRACTICAL PURPOSES, IF WE KEEP THE LOAD RESISTANCE FAIRLY HIGH (SAY AT LEAST 10 TIMES THE TOTAL POTENTIOMETER RESISTANCE), WE CAN IGNORE THE EFFECT OF THE LOAD RESISTANCE FOR MOST TRIMMER APPLICATIONS.

AS THE WIPER CONTACT IN FIGURE 1 IS MOVED, THE VALUES OF BOTH R_1 AND R_2 CHANGE, PRODUCING A CHANGE IN OUTPUT VOLTAGE (E_o) THAT IS DIRECTLY PROPORTIONAL TO THE WIPER POSITION (FIGURE 2).

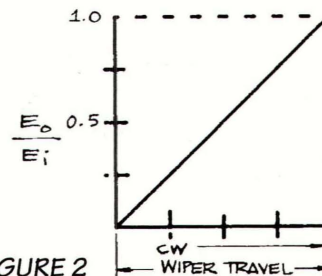

FIGURE 2

FOR SPECIAL APPLICATIONS (I.E., AUDIO VOLUME CONTROLS), SOME POTENTIOMETERS ARE DESIGNED TO PRODUCE AN OUTPUT THAT IS NOT LINEAR. TRIMMERS, ON THE OTHER HAND, ARE SELDOM USED IN THESE TYPES OF APPLICATIONS. THEY ARE USUALLY DESIGNED TO PRODUCE THE NOMINALLY LINEAR OUTPUT SHOWN IN FIGURE 2.

IN THE RHEOSTAT MODE, THE TRIMMER IS CONNECTED AS A TWO-TERMINAL DEVICE, AS SHOWN IN FIGURES 3a AND 3b. IN THIS MODE OF OPERATION, WHICH ACCOUNTS FOR OVER HALF OF ALL TRIMMER APPLICATIONS, THE POTENTIOMETER IS USED SIMPLY AS A VARIABLE RESISTOR TO CONTROL THE FLOW OF CURRENT IN A SERIES OF CIRCUIT.

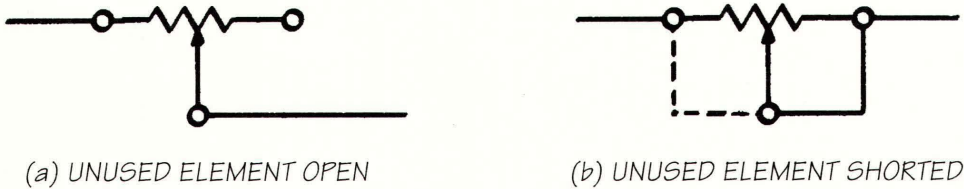

FIGURE 3 - RHEOSTAT MODE

IN THE RHEOSTAT MODE, THERE IS NO BASIC INPUT-OUTPUT RELATIONSHIP, EXCEPT AS DEFINED BY THE ASSOCIATED CIRCUITRY IN WHICH THE TRIMMER IS BEING USED.

FOR EXAMPLE, IN FIGURE 4, WE CAN SEE THAT AS THE WIPER CONTACT IS MOVED IN THE CW DIRECTION, AN INCREASING PORTION OF THE RESISTANCE ELEMENT IS SHORTED OUT BY THE JUMPER CONNECTION BETWEEN TERMINALS 1 AND 2. THIS REDUCES THE TOTAL RESISTANCE OF THE TRIMMER AND ALLOWS AN INCREASE IN THE FLOW OF CURRENT (I_L) TO THE LOAD (R_L).

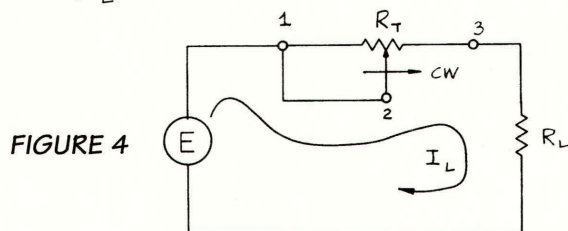

FIGURE 4

THIS MEANS THAT VIRTUALLY ALL OF THE LOAD CURRENT PASSES THROUGH THE WIPER CONTACT. AND YOU MUST REMEMBER THAT IN THE RHEOSTAT MODE OF OPERATION, THE MAXIMUM CURRENT IN THE CIRCUIT IS LIMITED ONLY BY THE SOURCE VOLTAGE AND LOAD RESISTANCE AS THE WIPER IS ADJUSTED TO THE POSITION OF MINIMUM RESISTANCE.

Here's How to Participate:

Beginning in May 1998, EDN has been publishing excerpts from Bourns' popular "Trimmer Primer" series each month. To participate fully in the program, Bourns will send you a 3-ring binder to house your information, technical articles, white papers and more. To get started, order your binder or any materials you may not have received, contact us via:

e-mail: techweb@bourns.com • FAX: (909) 781-5273 (North America); +41- 41 7685510 (Europe) or the Bourns Web Site: www.bourns.com

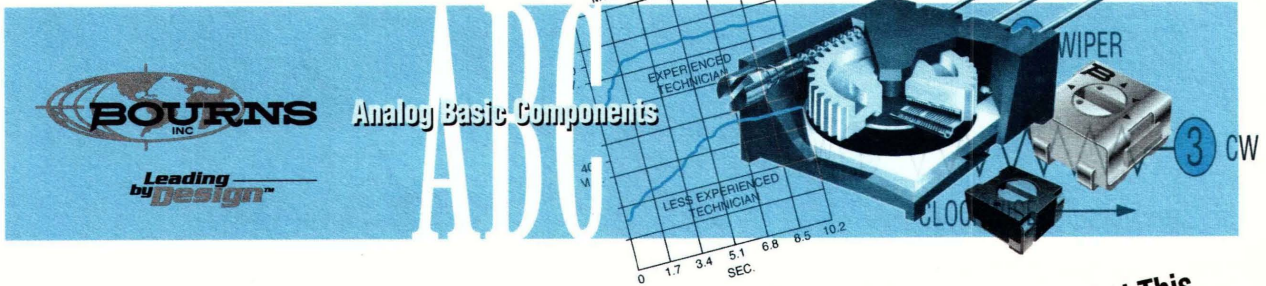

LINEARITY, ADJUSTABILITY AND RESOLUTION

You Won't Find This
FREE
Info in Any Catalog!

AS WE MENTIONED EARLIER, TRIMMERS ARE NORMALLY DESIGNED TO PRODUCE A LINEAR OUTPUT. HOWEVER, AS YOU MAY HAVE ALREADY SURMISED FROM WORKING WITH OTHER ELECTRICAL COMPONENTS, THEY'RE NOT EXACTLY PERFECT.

THE CHANGE IN OUTPUT AS A FUNCTION OF WIPER TRAVEL CAN DEVIATE FROM THE OPTIMUM AS ILLUSTRATED IN FIGURE 5a. HOWEVER, OVERALL LINEARITY IS USUALLY NO PROBLEM IN MOST TRIMMER APPLICATIONS, AND IS NEVER SPECIFIED.

ON THE OTHER HAND, IF WE MAGNIFY THE OUTPUT CURVE (FIGURE 5b), YOU CAN SEE THAT WHAT APPEARED TO BE A SMOOTH STRAIGHT LINE IS REALLY A SERIES OF VERY SMALL IRREGULARITIES. SOMETIMES WE REFER TO THEM AS "MICRO-NONLINEARITIES." MOST DESIGNERS USUALLY JUST CALL THEM "NOISE".



MORE OFTEN THAN NOT, THIS NOISE IS CAUSED BY SMALL IMPERFECTIONS IN THE COMPOSITION OF THE RESISTANCE ELEMENT AND CHANGES IN THE ELECTRICAL CURRENT PATH AS THE WIPER TRAVELS OVER THE ELEMENT.

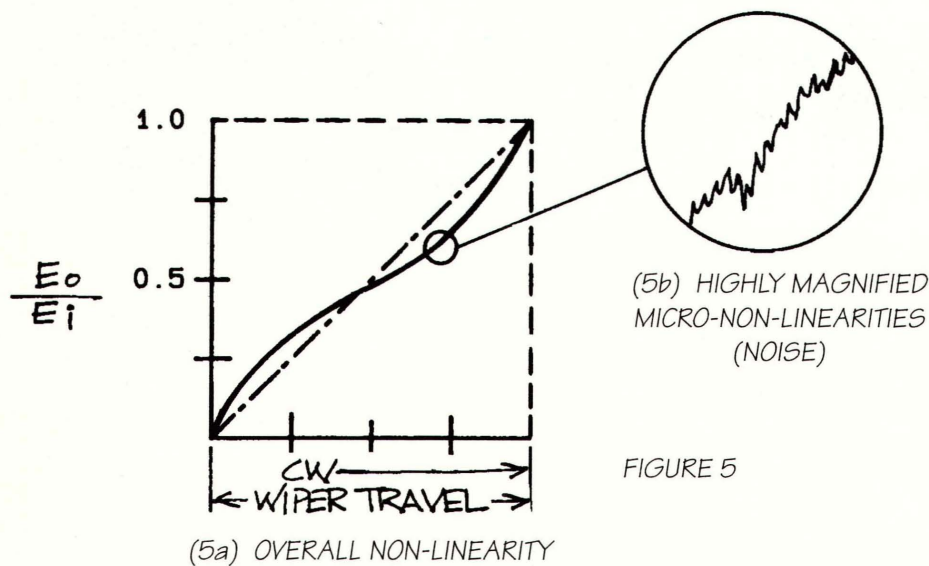

AS SMALL AS THEY ARE, THEY'RE IMPORTANT IN TRIMMER APPLICATIONS BECAUSE THEY EFFECTIVELY LIMIT THE ADJUSTABILITY (RESOLUTION) AND STABILITY OF THE UNIT.

MOST SINGLE-TURN TRIMMERS CAN BE SET TO WITHIN 0.05% OF THE TOTAL APPLIED VOLTAGE (VOLTAGE DIVIDER MODE) OR 0.15% OF TOTAL RESISTANCE (RHEOSTAT MODE). HOWEVER, FOR SOME APPLICATIONS, THAT'S NOT GOOD ENOUGH. SO THERE ARE TWO WAYS YOU CAN GET AROUND IT.

1. USE A MULTITURN UNIT TO GIVE BETTER ADJUSTABILITY.
2. USE ADDITIONAL FIXED RESISTORS AS PART OF THE ADJUSTMENT NETWORK TO YIELD THE DESIRED FINE ADJUSTMENT CHARACTERISTICS.

ADDING RESISTANCE IN SERIES WITH THE TRIMMER WILL REDUCE THE OVER-ALL ADJUSTMENT RANGE OF THE CIRCUIT, BUT WILL ALLOW FINER TUNING.

Here's How to Participate:

Beginning in May 1998, EDN has been publishing excerpts from Bourns' popular "Trimmer Primer" series each month. To participate fully in the program, Bourns will send you a 3-ring binder to house your information, technical articles, white papers and more. To get started, order your binder or any materials you may not have received, contact us via:

e-mail: techweb@bourns.com • FAX: (909) 781-5273 (North America); +41- 41 7685510 (Europe) or the Bourns Web Site: www.bourns.com

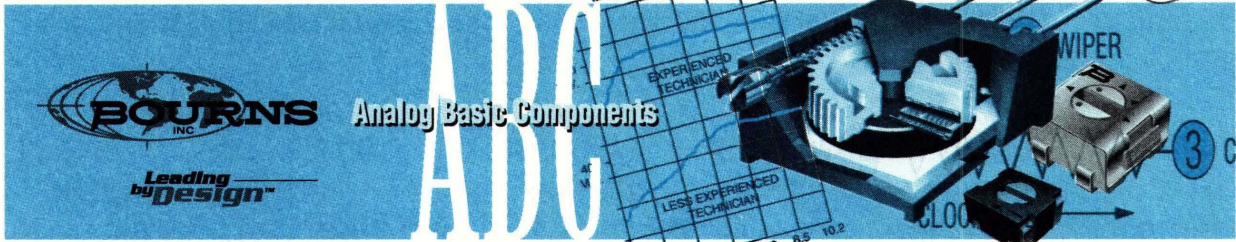

END ZONE CHARACTERISTICS

You Won't Find This
FREE
Info in Any Catalog!

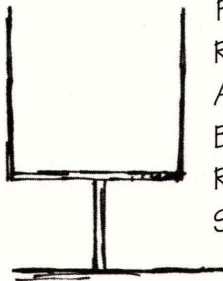

POTENTIOMETERS NORMALLY HAVE A SMALL REGION AT THE EXTREME ENDS OF THE ADJUSTMENT RANGE WHERE THE OUTPUT IS IRREGULAR. THIS CAN BE SEEN WHEN THERE'S A SUDDEN DROP TO ESSENTIALLY ZERO RESISTANCE. OR THE CHANGE IN OUTPUT WILL STOP AT SOME SMALL RESIDUAL VALUE OF RESISTANCE, DEPENDING ON THE DESIGN OF THE TRIMMER.

ALTHOUGH THIS UNSTABLE REGION IS USUALLY LESS THAN 1 OR 2% OF THE TOTAL RANGE OF ADJUSTMENT, IT'S IMPORTANT THAT YOU REMEMBER TO MAKE ALLOWANCES FOR AVOIDING IT IN YOUR CIRCUIT APPLICATIONS.

POWER AND CURRENT RATINGS

THE POWER RATINGS OF TRIMMING POTENTIOMETERS ARE USUALLY MORE THAN ADEQUATE FOR MOST VOLTAGE DIVIDER APPLICATIONS WHERE THE POWER IS DISSIPATED EVENLY OVER THE ENTIRE LENGTH OF THE ELEMENT UNDER ALL CIRCUMSTANCES.

KEEP IN MIND, HOWEVER, THAT THE STATED POWER RATING IS FOR THE ENTIRE RESISTANCE ELEMENT. UNUSUALLY LOW VALUES OF LOAD RESISTANCE CAN CAUSE UNEXPECTED HIGH LEVELS OF POWER DISSIPATION IN THE UNLOADED PORTION OF THE ELEMENT WHEN THE WIPER IS SET AT HIGH VALUES OF VOLTAGE RATIO.

FORTUNATELY, POWER DISSIPATION AND WIPER CURRENT USUALLY ONLY BECOME PROBLEMS WHEN TRIMMERS ARE USED IN THE RHEOSTAT MODE. LIKE WE SAID EARLIER, IN THIS MODE THE CURRENT THROUGH THE TRIMMER ELEMENT AND THE WIPER CONTACT IS LIMITED ONLY BY EXTERNAL CIRCUIT CONDITIONS.

THIS IS WHERE YOU AS A DESIGNER MUST MAKE SURE YOU LIMIT THE WIPER CURRENT TO THE MAXIMUM VALUE STATED IN THE TRIMMER SPECS. IF YOU DON'T - ZAP!!!

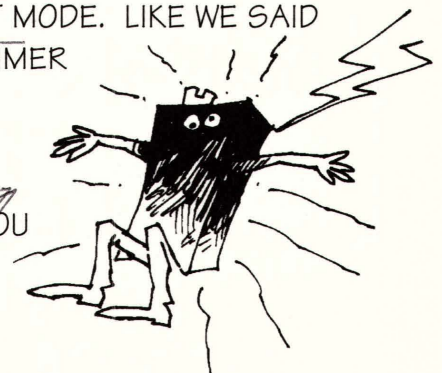

EXCEEDING THE MAXIMUM WIPER CURRENT HAS CAUSED MORE TRIMMER PROBLEMS THAN ANY OTHER DESIGN ERROR.

IF THE MAXIMUM WIPER CURRENT SPEC ISN'T AVAILABLE, YOU CAN SAFELY ASSUME THAT IT IS THE CURRENT THAT WOULD PRODUCE MAXIMUM POWER DISSIPATION IN THE TRIMMER, IF APPLIED THROUGH THE ELEMENT ONLY, PROVIDED IT DOESN'T EXCEED 100 MILLIAMPS.

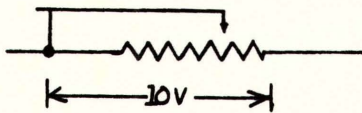

CAUTION! THIS CAN BECOME A DIRECT SHORT –
AND THEN

ZAP!

(SEE CURRENT LIMITS IN TABLE 1)

THE TABLE BELOW SHOWS THE MAXIMUM WIPER CURRENT FOR DECADE RESISTANCE VALUES FOR SEVERAL TRIMMER POWER RATINGS. THE 100 MILLIAMP MAXIMUM WIPER CURRENT RATING (#) IS APPLICABLE ONLY ON TRIMMER VALUES OF LESS THAN 100 OHMS.

TABLE 1 - MAXIMUM WIPER CURRENT VERSUS POWER RATINGS.

Trimmer Resistance	0.25 Watt	0.5 Watt	1.0 Watt
10 OHMS	100 MA #	100 MA #	100 MA #
100 OHMS	50 MA	71 MA	100 MA
1K OHMS	16 MA	22 MA	32 MA
10K OHMS	5.0 MA	7.1 MA	10 MA
100K OHMS	1.6 MA	2.2 MA	3.2 MA
1M OHMS	0.5 MA	0.7 MA	1.0 MA

Here's How to Participate:

Beginning in May 1998, EDN has been publishing excerpts from Bourns' popular "Trimmer Primer" series each month. To participate fully in the program, Bourns will send you a 3-ring binder to house your information, technical articles, white papers and more. To get started, order your binder or any materials you may not have received, contact us via:

*e-mail: techweb@bourns.com • FAX: (909) 781-5273 (North America); +41- 41 7685510 (Europe)
or the Bourns Web Site: www.bourns.com*



RESISTANCE VALUES AND TOLERANCES

You Won't Find This
FREE
Info in Any Catalog!

WHILE IT'S ALWAYS EASIER TO WORK WITH STANDARD PARTS INVENTORIES, YOU STILL HAVE TO KEEP IN MIND THAT TO REACH OPTIMUM STABILITY AND ADJUSTABILITY, YOU NEED TO USE THE SMALLEST VALUE OF TRIMMER RESISTANCE YOUR APPLICATION ALLOWS.

HERE'S ANOTHER TIDBIT. WHEN YOU'RE WORKING IN CRITICAL APPLICATIONS, TRY TO AVOID THE EXTREMES OF RESISTANCE RANGE WHEN YOU'RE SELECTING A TRIMMER. ALTHOUGH THE ENTIRE RANGE WILL MEET THE STATED SPECIFICATIONS, MID-RANGE VALUES TEND TO PERFORM BETTER THAN LOW AND HIGH VALUES.

DRY CIRCUIT CONDITIONS

AS FAR AS POTENTIOMETERS GO, DRY CIRCUIT CONDITIONS RESULT FROM EXTREMELY LOW VALUES OF WIPER CURRENT. PAST STUDIES SHOW THAT UNDER EXTENDED TIME AND TEMPERATURE CONDITIONS, OXIDE FILMS CAN FORM AT THE JUNCTION OF METALLIC ELECTRICAL CONTACTS, SIMILAR TO THE POINT OF CONTACT BETWEEN MECHANICAL SWITCHING ELEMENTS. USUALLY THIS DOESN'T CAUSE A PROBLEM IN TRIMMER APPLICATIONS, SINCE NORMAL OPERATING CURRENT LEVELS PRODUCE ENOUGH "PUNCH THROUGH" VOLTAGE AT THE WIPER JUNCTION TO BREAK DOWN OXIDE OR CONTAMINANT FILMS.

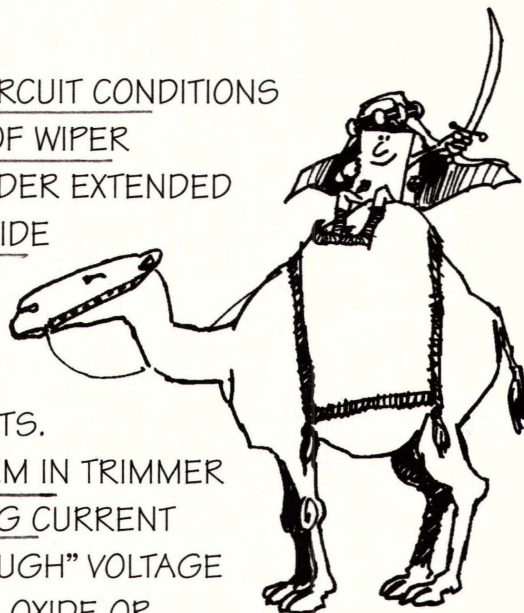

BUT WITH THE TREND TOWARD LOWER LEVELS OF CURRENT OPERATION, DRY CIRCUIT CONDITIONS CAN LEAD TO SOME DEGRADATION IN PERFORMANCE – ESPECIALLY IN THE AREA OF LONG-TERM STABILITY.

EXTENSIVE TESTING HAS BEEN CONDUCTED TO BETTER DEFINE DRY CIRCUIT CONDITIONS FOR NON-METALLIC JUNCTIONS IN COMPOSITION POTENTIOMETERS. WE RECOMMEND THAT YOU PROVIDE A LOW ENOUGH LOAD RESISTANCE ACROSS THE WIPER OF THE POTENTIOMETER TO ENSURE AN ABSOLUTE MINIMUM WIPER CURRENT OF 25 MICROAMPS AND PREFERABLY OVER 100 MICROAMPS. THIS SHOULD GIVE YOU ENOUGH CURRENT THROUGH THE WIPER TO HELP YOU AVOID DRY CIRCUIT PROBLEMS OVER EXTENDED PERIODS OF TIME AND TEMPERATURE.

Here's How to Participate:

Beginning in May 1998, EDN has been publishing excerpts from Bourns' popular "Trimmer Primer" series each month. To participate fully in the program, Bourns will send you a 3-ring binder to house your information, technical articles, white papers and more. To get started, order your binder or any materials you may not have received, contact us via:

*e-mail: techweb@bourns.com • FAX: (909) 781-5273 (North America); +41- 41 7685510 (Europe)
or the Bourns Web Site: www.bourns.com*

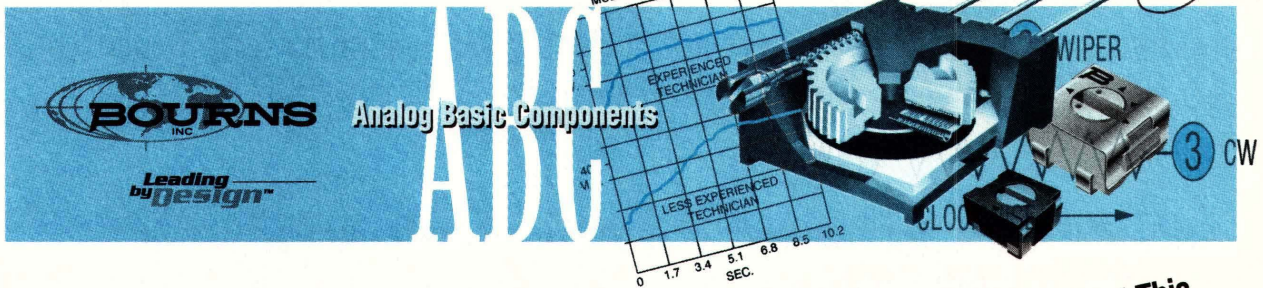

MORE CIRCUIT APPLICATIONS

You Won't Find This
FREE
Info in Any Catalog!

LET'S TAKE A LOOK AT A FEW OF THE MORE POPULAR ACTUAL CIRCUIT APPLICATIONS THAT USE TRIMMERS. WE'LL SHOW YOU HOW TO IMPROVE CIRCUIT PERFORMANCE WITH PROPER SELECTION AND USE OF THE TRIMMERS.

ONE OF THE MOST COMMON TRIMMER POTENTIOMETER APPLICATIONS TODAY IS THE ADJUSTMENT OF OFFSET VOLTAGE IN OPERATIONAL AMPLIFIERS, FIGURE 6.

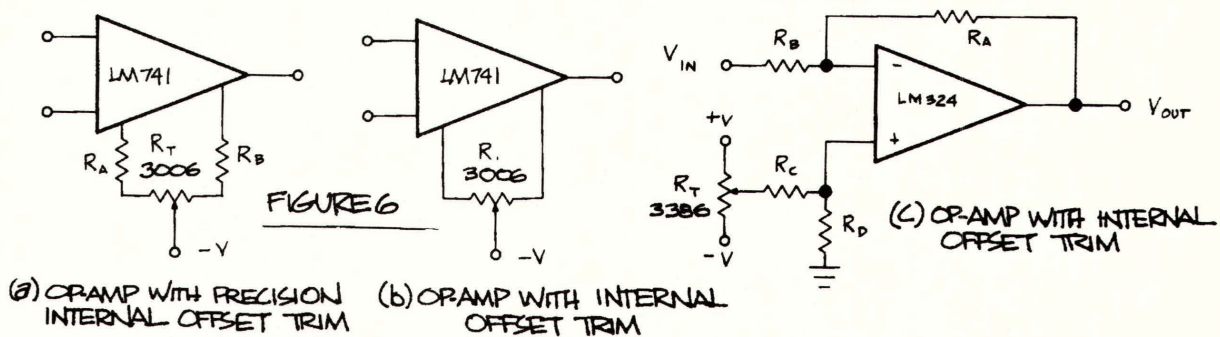

IN SOME CASES IT IS IMPOSSIBLE OR UNDESIRABLE TO TRIM INPUT OFFSET VOLTAGE USING MANUFACTURER-PROVIDED TERMINALS AS SHOWN ABOVE. OTHER EXTERNAL CIRCUITS HAVE BEEN DEVELOPED TO COMPENSATE FOR THE OP-AMP OFFSET ADJUST TERMINALS.

THE OFFSET VOLTAGE MAY EITHER BE POSITIVE OR NEGATIVE WITH RESPECT TO THE GROUND, SO THE COMPENSATING VOLTAGE PROVIDED BY THE TRIMMING NETWORK MUST ALSO BE ADJUSTABLE OVER A POSITIVE TO NEGATIVE RANGE THAT IS GREAT ENOUGH TO INCLUDE THE HIGHEST AND LOWEST OFFSET VOLTAGE THAT MAY BE ENCOUNTERED. USE OF A CENTER

TAPPED ELEMENT REDUCES POWER SUPPLY SENSITIVITY BY ISOLATING THE SUPPLIES, MINIMIZING THE EFFECTS OF SUPPLY DRIFT ON THE OFFSET ADJUSTMENT VOLTAGE.



SINCE YOU MAY ALSO REDUCE THE NUMBER OF COMPONENTS IN THE NETWORK BY EMPLOYING A CENTER TAPPED ELEMENT, YOU WILL ALSO SEE IMPROVEMENTS IN THE THERMAL STABILITY OF THE OFFSET VOLTAGE PERFORMANCE OF YOUR SYSTEM.

MOST OF THE PROBLEMS YOU HAVE IN THIS APPLICATION ARE USUALLY DUE TO THERMOELECTRIC EFFECTS. SMALL VOLTAGES ARE GENERATED AT THE ELEMENT TERMINATION POINTS AND AT THE TRIMMER-TO-CIRCUIT-BOARD INTERFACE. THIS IS DUE TO THE DISSIMILAR METALS USED IN THE MANUFACTURING PROCESS.



Here's How to Participate:

Beginning in May 1998, EDN has been publishing excerpts from Bourns' popular "Trimmer Primer" series each month. To participate fully in the program, Bourns will send you a 3-ring binder to house your information, technical articles, white papers and more. To get started, order your binder or any materials you may not have received, contact us via:

*e-mail: techweb@bourns.com • FAX: (909) 781-5273 (North America); +41- 41 7685510 (Europe)
or the Bourns Web Site: www.bourns.com*

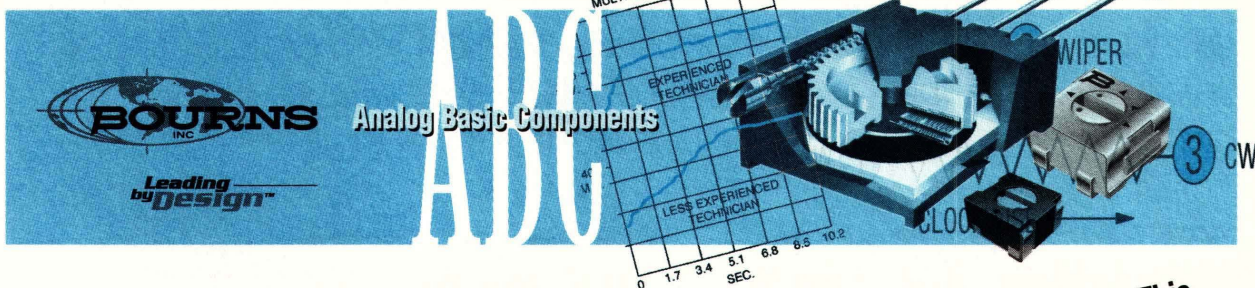

MORE CIRCUIT APPLICATIONS (Cont'd from previous issue)

You Won't Find This
FREE
Info in Any Catalog!

IF THE TRIMMER IS AT THE SAME TEMPERATURE, THESE VOLTAGES WILL BALANCE OUT AND HAVE NO NET EFFECT ON CIRCUIT OPERATION. HOWEVER, IF THERE'S A THERMAL GRADIENT ACROSS THE TERMINALS OF THE TRIMMER, ENOUGH DIFFERENTIAL VOLTAGE MAY BE GENERATED TO DISTURB THE BALANCE OF YOUR CIRCUIT. THE EMF GENERATED WILL DEPEND ON THE MAGNITUDE OF THE TEMPERATURE GRADIENT AND THE MATERIALS USED IN THE TRIMMER AND CIRCUIT BOARD. UNDER EXTREME CONDITIONS, THE THERMAL EMF CAN BE AS HIGH AS 100 MICROVOLTS.

YOU CAN'T ELIMINATE THE THERMAL EMF PROBLEM ENTIRELY. BUT YOU CAN MINIMIZE IT. TRY TO KEEP THE OP AMP AND THE TRIMMER OUT OF ENVIRONMENTS THAT HAVE HIGH THERMAL GRADIENTS. AVOID PLACING THE TRIMMER NEAR HOT COMPONENTS.

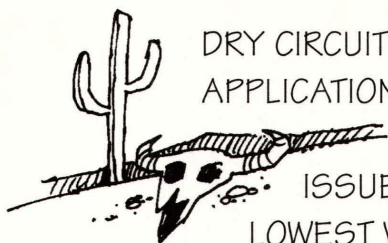

DRY CIRCUIT CONDITIONS CAN ALSO BE A PROBLEM IN THIS APPLICATION, PARTICULARLY WHEN THE TRIMMER IS USED FOR INTERNAL OFFSET TRIM AS SHOWN IN THE PREVIOUS ISSUE'S FIGURES 6(a) AND 6(b). ALWAYS SELECT THE LOWEST VALUE OF TRIM NETWORK RESISTANCE COMPATIBLE WITH THE OP AMP MANUFACTURER'S RECOMMENDATIONS, REMEMBERING THAT GOING TOO LOW WILL GOBBLE UP THE OP AMP'S OFFSET THERMAL DRIFT CHARACTERISTICS.

IN EXTERNAL OFFSET TRIM CIRCUITS AS SHOWN IN THE PREVIOUS ISSUE'S FIGURE 6(c), TRY TO KEEP R_T , R_C , AND R_D AS LOW AS YOU REASONABLY CAN, AGAIN TO MINIMIZE DRY CIRCUIT PROBLEMS.

LIKE WE SAID EARLIER, OVER HALF OF ALL TRIMMER APPLICATIONS ARE IN THE RHEOSTAT MODE – TWO EXAMPLES ARE THE VOLTAGE REGULATOR CIRCUIT IN FIGURE 7 AND OP AMP CIRCUITS IN FIGURE 8.

FIGURE 7 (a)

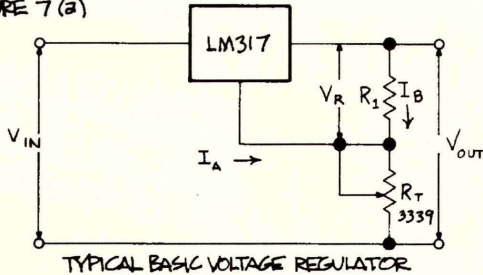

FIGURE 7 (b)

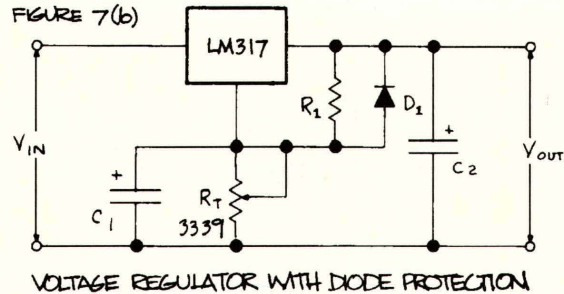
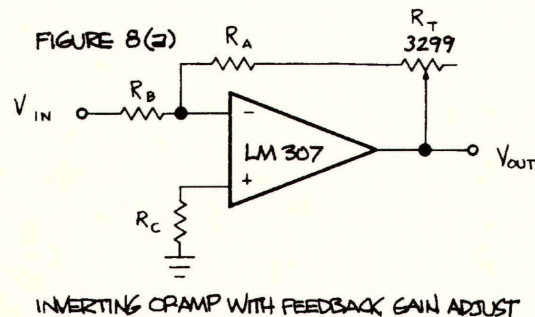
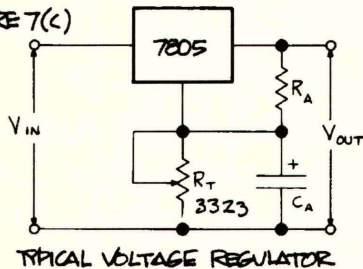

FIGURE 7 (c)



OUR STUDY SHOWED US THAT IN ABOUT HALF THE RHEOSTAT APPLICATIONS, DESIGNERS USE THIS CONFIGURATION BY MAKING CONNECTIONS TO ONE END OF THE RESISTANCE ELEMENT AND THE WIPER, LEAVING THE OTHER ELEMENT TERMINAL OPEN AS SHOWN IN FIGURE 8a.

Here's How to Participate:

Beginning in May 1998, EDN has been publishing excerpts from Bourns' popular "Trimmer Primer" series each month. To participate fully in the program, Bourns will send you a 3-ring binder to house your information, technical articles, white papers and more. To get started, order your binder or any materials you may not have received, contact us via:

e-mail: techweb@bourns.com • FAX: (909) 781-5273 (North America); +41- 41 7685510 (Europe)
or the Bourns Web Site: www.bourns.com



WHAT IS AN ENCODER?

IN SIMPLEST TERMS, AN ENCODER IS ANY DEVICE THAT CONVERTS ANALOG SIGNALS, SHAFT POSITIONS, OR OTHER ANALOG PARAMETERS TO DIGITAL FORM.

IN GRAPHIC TERMS, THIS ENCODER DISK IS USED TO CONVERT SHAFT POSITION TO CORRESPONDING DIGITAL VALUE REPRESENTING ANGULAR DEGREES.

You Won't Find This
FREE
Info in Any Catalog!

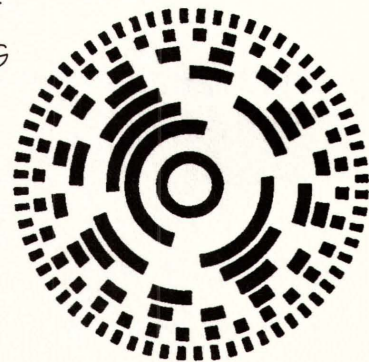
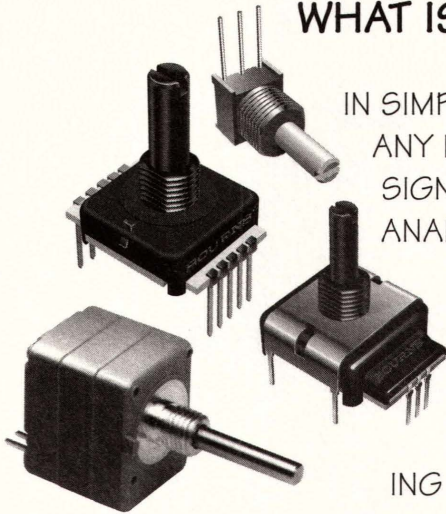

DIFFERENCES FROM OTHER COMPONENTS

AN ENCODER FUNCTIONS DIFFERENTLY IN A SYSTEM FROM A PANEL CONTROL OR PRECISION POTENTIOMETER, EVEN THOUGH EXTERNALLY THEY APPEAR TO BE SIMILAR.

AMONG THE SPECIAL CAPABILITIES OF AN ENCODER ARE:

- DIRECTION OF ROTATION
- UP/DOWN COUNTING
- ANGULAR POSITION
- SPEED OF ROTATION

TODAY'S ENGINEERS ARE MOVING AWAY FROM ANALOG DEVICES AND ARE LOOKING FOR LOW-COST ENCODERS WHICH PROVIDE A VERY ACCURATE DIGITAL SIGNAL AND CAN BE INTERPRETED THOUSANDS OF WAYS DEPENDING ON YOUR CUSTOMER'S REQUIREMENTS.

INSTRUMENTATION	• TEST EQUIPMENT / SCOPES
ROBOTICS	• ANIMATED "DINOSAURS" - JURASSIC PARK
AUDIO	• HIGH-END MIXING BOARDS
	• VOLUME CONTROL/STATION SELECT - AUTOMOBILE STEREO SYSTEMS
MEDICAL	• ULTRASOUND IMAGING EQUIPMENT
COMPUTER	• TRACK BALL OR MOUSE CONTROLS

TYPES OF ENCODERS

1. INCREMENTAL CONTACTING

TWO CHANNEL GRAY CODED SIGNAL ALLOWS THE USER'S DECODER CIRCUIT TO SENSE ANALOG DIRECTION OF ROTATION. THE BIG ADVANTAGE OF THE INCREMENTAL CONTACTING ENCODER IS THAT IT PERMITS THE DIRECT ENTRY OF DIGITIZED ANALOG DATA INTO THE CIRCUIT WITHOUT A/D CONVERSION.

ENCODER CONSTRUCTION:

- AN ELEMENT
- A MOVEABLE CONTACT (WIPER)
- END TERMINALS
- A CONTACT ACTUATOR (SHAFT/ROTOR ASSEMBLY)

PACKAGE SIZES:

SIZES RANGE FROM AS SMALL AS 6MM UP TO 22MM AND LARGER.

OUTPUT TABLE:

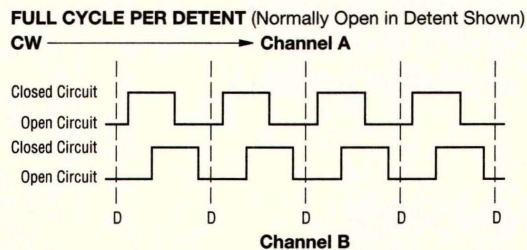

RECOMMENDED
INCREMENTAL CONTROL
DIAGRAM:

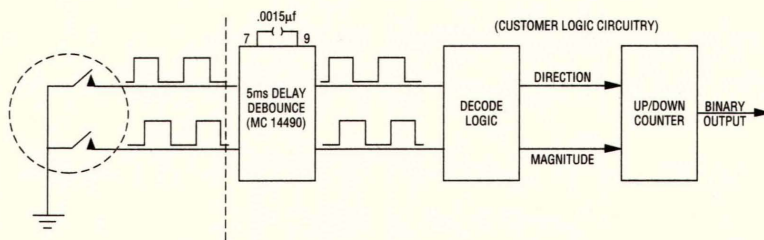

Here's How to Participate:

Beginning in May 1998, EDN has been publishing excerpts from Bourns' popular "Trimmer Primer" series and other material each month. To participate fully in the program, Bourns will send you a 3-ring binder to house your information, technical articles, white papers and more. To get started, order your binder or any materials you may not have received, contact us via:

**e-mail: techweb@bourns.com • FAX: (909) 781-5273 (North America); +41- 41 7685510 (Europe)
or the Bourns Web Site: www.bourns.com**



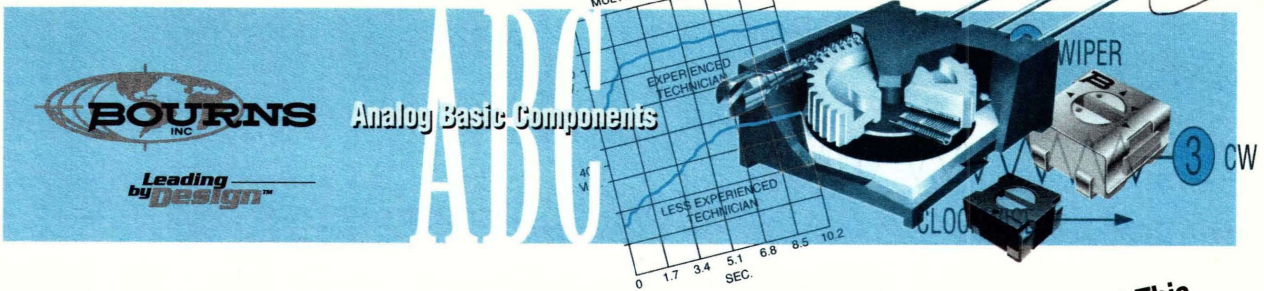

TYPES OF ENCODERS (Continued from Previous Issue)

You Won't Find This
FREE
Info in Any Catalog!

2. ABSOLUTE CONTACTING ENCODERS (ACE™)

THE GRAY CODE PATTERN OF THE ABSOLUTE CONTACTING ENCODER (ACE™) IS PLACED ON A SINGLE TRACK FOR A VERY ECONOMICAL, ENERGY-EFFICIENT AND COMPACT PRODUCT. ABSOLUTE CONTACTING ENCODERS PROVIDE AN ABSOLUTE DIGITAL OUTPUT THAT WILL ALSO RETAIN ITS LAST POSITION IN THE EVENT OF A POWER FAILURE!

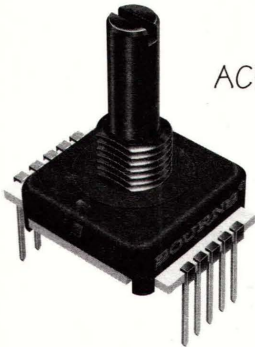

ACE™ CONSTRUCTION:

- AN ELEMENT
- A MOVEABLE CONTACT (WIPER)
- ACCESS TERMINALS
- A CONTACT ACTUATOR (SHAFT/ROTOR ASSEMBLY)

OUTPUT:

- 8 BIT GRAY CODE WITH UP TO 128 ABSOLUTE STATES DEPENDING ON PACKAGE SIZE AND CONSTRUCTION.

TYPICAL CONTROL DIAGRAM FOR ABSOLUTE CONTACTING ENCODERS:

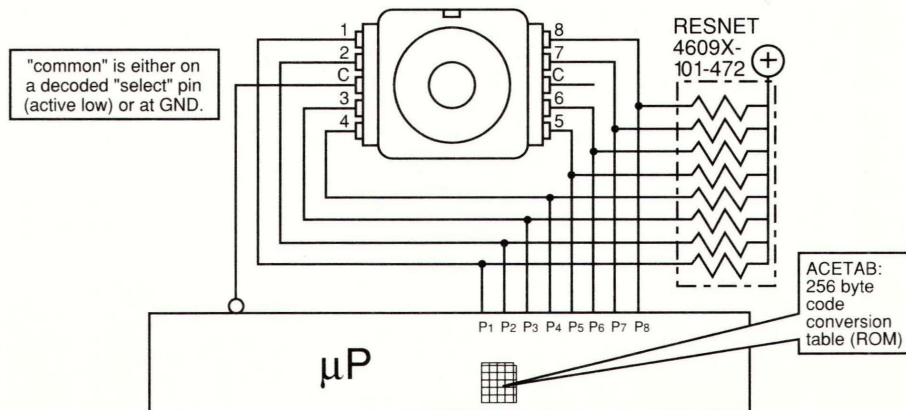

TYPES OF ENCODERS (Continued)

2. INCREMENTAL NON-CONTACTING OPTICAL ENCODERS

TWO CHANNEL GRAY CODE SIGNAL ALLOWS THE USER'S DECODER CIRCUIT TO SENSE ANALOG DIRECTION OF ROTATION. THE NON-CONTACTING ENCODER PERFORMS THE SAME FUNCTIONS AS THE CONTACTING VERSION BUT THERE ARE SOME REAL ADVANTAGES TO THE OPTICAL ENCODER. THEY INCLUDE:

- HIGH ROTATIONAL LIFE
- HIGH SPEED ACCURACY
- RESOLUTIONS UP TO 256 COUNTS PER 360° MECHANICAL ROTATION

OPTICAL INCREMENTAL ENCODERS:

- UTILIZE LED AND SENSOR BOARD TECHNOLOGY INSTEAD OF ROTOR/ WIPER ASSEMBLIES.
- PACKAGE SIZES RANGE FROM 5/8" SQUARE AND UP.
- INDEX PULSING IS ALSO AVAILABLE.

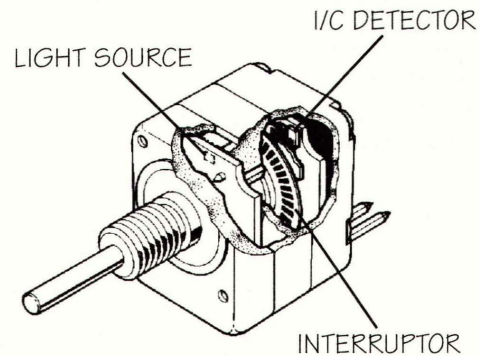

CUTAWAY ILLUSTRATION

Here's How to Participate:

Beginning in May 1998, EDN has been publishing excerpts from Bourns' popular "Trimmer Primer" series and other material each month. To participate fully in the program, Bourns will send you a 3-ring binder to house your information, technical articles, white papers and more. To get started, order your binder or any materials you may not have received, contact us via:

*e-mail: techweb@bourns.com • FAX: (909) 781-5273 (North America); +41- 41 7685510 (Europe)
or the Bourns Web Site: www.bourns.com*



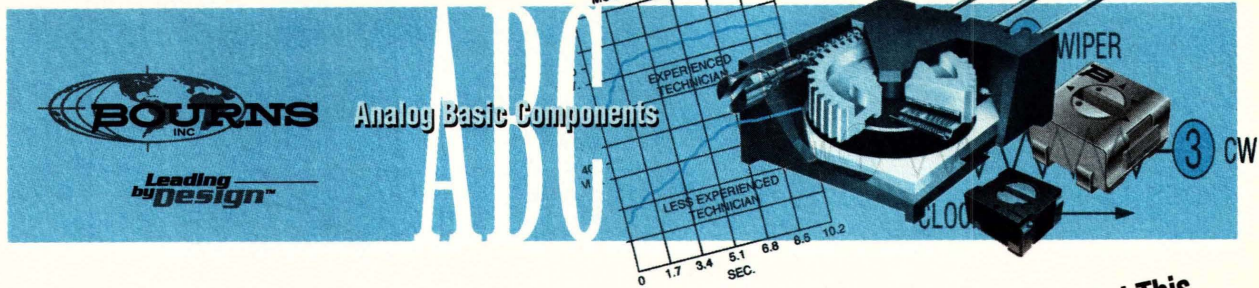

MOST FREQUENTLY ASKED QUESTIONS FROM ENGINEERS

You Won't Find This **FREE** Info in Any Catalog!

IF SOMEONE WERE TO ASK YOU, "WHAT IS LINEARITY?", COULD YOU ANSWER THEM?

THERE ARE SEVERAL TYPES OF LINEARITY:

1. INDEPENDENT
2. ABSOLUTE
3. ZERO-BASED

LET'S ANSWER THE QUESTION.

1. THE MOST COMMON LINEARITY IS DESCRIBED AS **INDEPENDENT**. INDEPENDENT LINEARITY IS DEFINED AS THE MAXIMUM PERMISSIBLE DEVIATION OF THE ACTUAL OUTPUT CURVE FROM A REFERENCE LINE.

THE REFERENCE LINE IS EXPRESSED BY THE MATHEMATICAL EQUATION:

$$\frac{E_o}{E_i} = M \left(\frac{\Theta_w}{\Theta_A} \right) + b$$

WHERE M IS AN UNSPECIFIED SLOPE, Θ_A IS THE ACTUAL ELECTRICAL TRAVEL, b IS THE UNSPECIFIED INTERCEPT VALUE OF THE OUTPUT RATIO AT $\Theta_w = 0$.

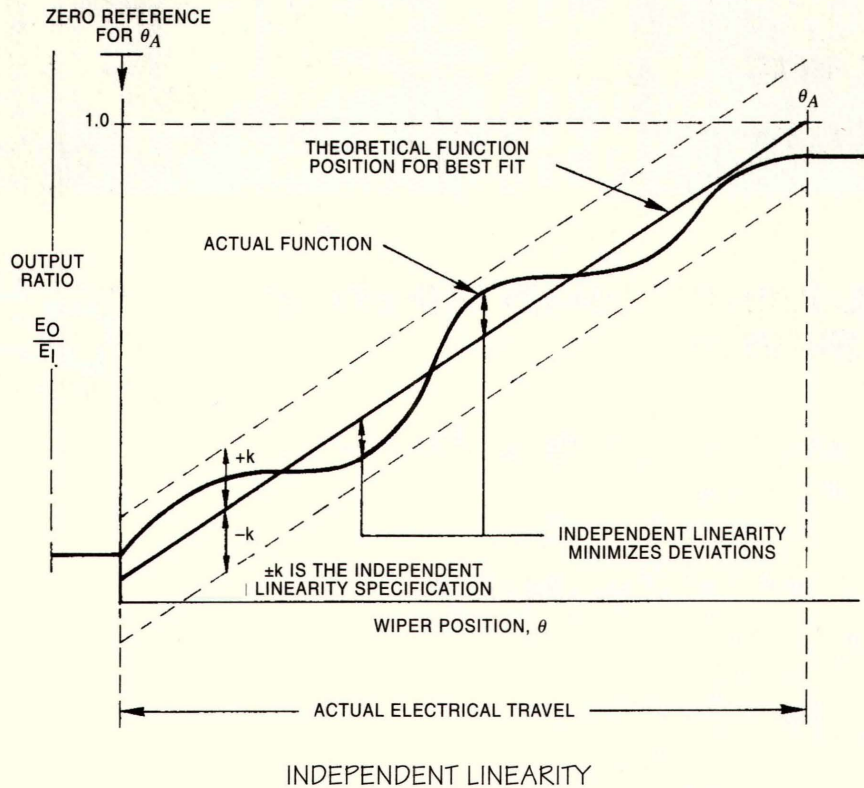

THIS DIAGRAM ILLUSTRATES CONDITIONS NECESSARY TO DEFINE INDEPENDENT LINEARITY. THE EXAGGERATED WAVY LINE REPRESENTS THE ACTUAL OUTPUT RATIO, AND IS MEASURED OVER THE TOTAL ACTUAL ELECTRICAL TRAVEL. THE REFERENCE LINE IS POSITIONED ON THE OUTPUT CURVE, WITHOUT REGARD FOR SLOPE AND INTERCEPT, SO THE POSITIVE AND NEGATIVE DEVIATIONS OR LINEARITY ERRORS ARE MINIMIZED.

Here's How to Participate:

Beginning in May 1998, EDN has been publishing excerpts from Bourns' popular "Trimmer Primer" series and other material each month. To participate fully in the program, Bourns will send you a 3-ring binder to house your information, technical articles, white papers and more. To get started, order your binder or any materials you may not have received, contact us via:

e-mail: techweb@bourns.com • FAX: (909) 781-5273 (North America); +41- 41 7685510 (Europe) or the Bourns Web Site: www.bourns.com



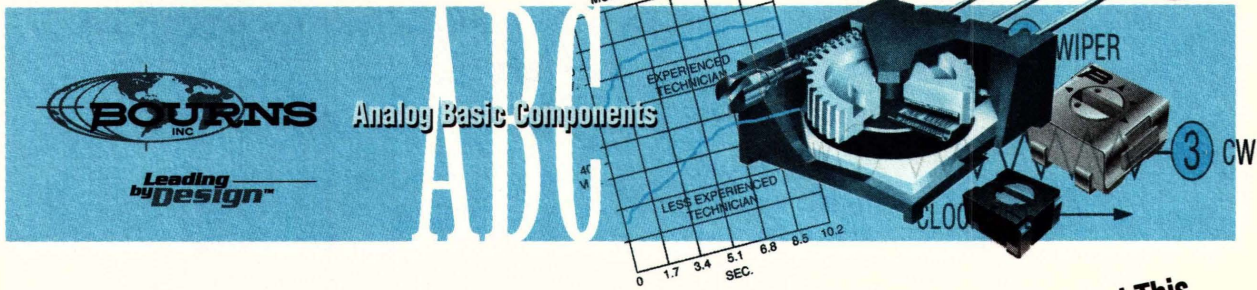

“WHAT IS LINEARITY?” (Continued from Previous Issue)

You Won't Find This
FREE
Info in Any Catalog!

2. **ABSOLUTE LINEARITY** IS DEFINED AS THE MAXIMUM PERMISSIBLE DEVIATION OF THE ACTUAL OUTPUT CURVE FROM A FULLY DEFINED STRAIGHT REFERENCE LINE. NOTE: AN INDEX POINT ON THE ACTUAL OUTPUT IS REQUIRED.

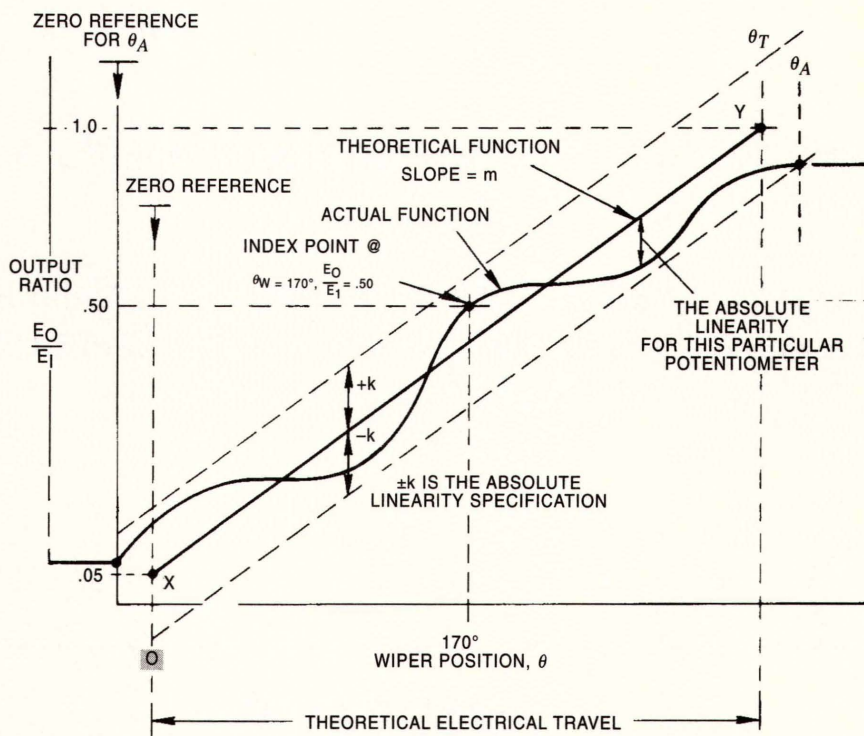

ABSOLUTE LINEARITY

THE REFERENCE LINE FOR ABSOLUTE LINEARITY MAY BE DESCRIBED MATHEMATICALLY AS:

$$\frac{E_0}{E_1} = M \left(\frac{\theta_W}{\theta_T} \right) + b$$

IN THE EXAMPLE ABOVE, THE LOWER LIMIT OF THE OUTPUT RATIO IS SPECIFIED AS 0.05. THEREFORE, THE VALUE OF b (INTERCEPT) MUST ALSO BE 0.05. IN ADDITION, THE UPPER LIMIT OF THE OUTPUT RATIO IS 1 WHEN:

$$\frac{\Theta_W}{\Theta_T} = 1.0$$

TO DETERMINE THE SLOPE, SUBSTITUTE THESE UPPER AND LOWER LIMIT VALUES IN THE GENERAL EQUATION AND SOLVE FOR M .

$$\frac{E_0}{E_1} = M \left(\frac{\Theta_W}{\Theta_T} \right) + b$$

$$1 = M(1) + .05$$

$$M = \frac{1 - .05}{1}$$

$$M = .95$$

FOR THIS EXAMPLE, THE INDEX POINT HAPPENS TO BE AT AN OUTPUT RATIO, $\frac{E_0}{E_1}$, OF 0.5 AND WIPER TRAVEL, Θ_W , OF 170°.

ABSOLUTE LINEARITY IS THE MOST PRECISE DEFINITION OF POTENTIOMETER OUTPUT BECAUSE THE GREATEST NUMBER OF LINEARITY PARAMETERS ARE CONTROLLED. THIS IS THE PRIMARY ADVANTAGE OF ABSOLUTE LINEARITY.

Here's How to Participate:

Beginning in May 1998, EDN has been publishing excerpts from Bourns' popular "Trimmer Primer" series and other material each month. To participate fully in the program, Bourns will send you a 3-ring binder to house your information, technical articles, white papers and more. To get started, order your binder or any materials you may not have received, contact us via:

*e-mail: techweb@bourns.com • FAX: (909) 781-5273 (North America); +41- 41 7685510 (Europe)
or the Bourns Web Site: www.bourns.com*



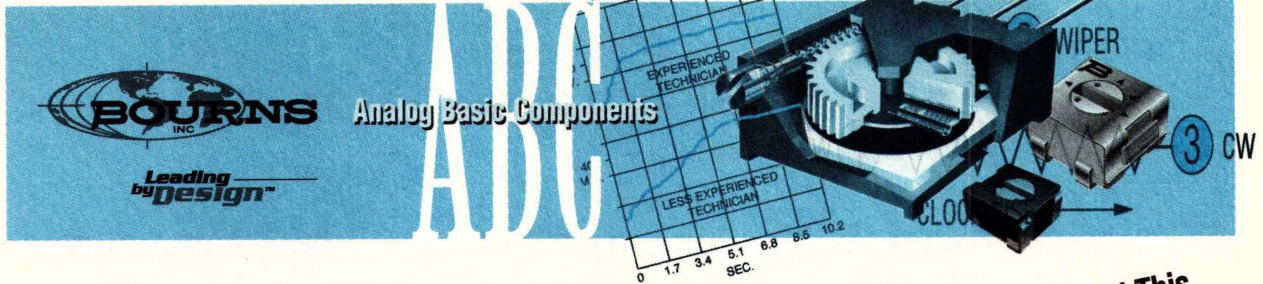

“WHAT IS LINEARITY?” (Continued from Previous Issue)

You Won't Find This
FREE
Info in Any Catalog!

3. **ZERO-BASED LINEARITY** IS DEFINED AS THE MAXIMUM RESULTING DEVIATION OF THE ACTUAL OUTPUT FROM THE STRAIGHT REFERENCE LINE. ESSENTIALLY, ZERO-BASED LINEARITY IS A SPECIAL CASE OF INDEPENDENT LINEARITY WHERE THE ZERO TRAVEL END OF THE THEORETICAL REFERENCE LINE IS SPECIFIED.

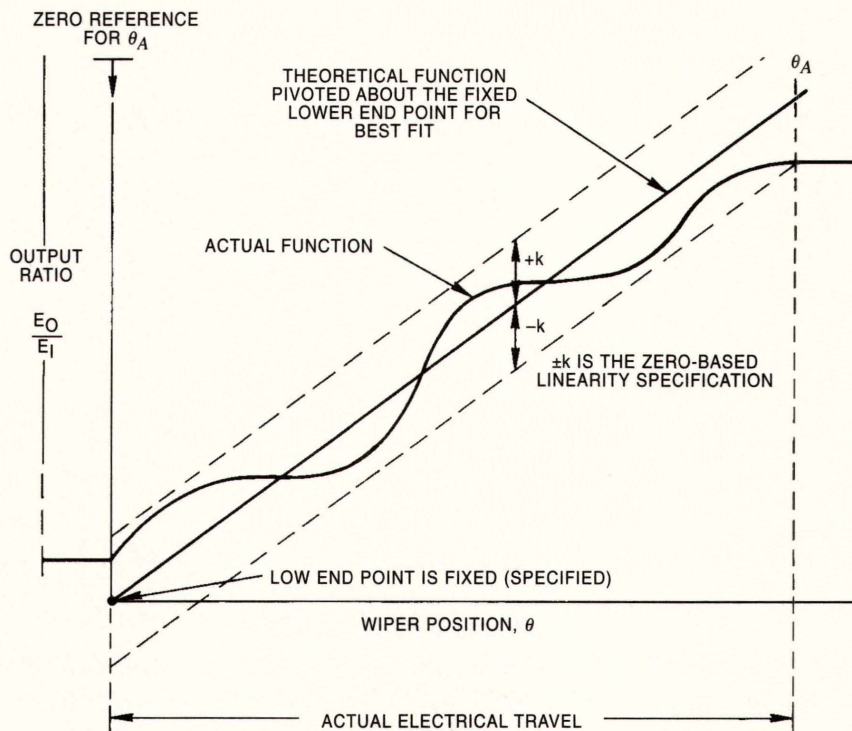

ZERO-BASED LINEARITY

THE SLOPE OF THE REFERENCE LINE IS CHOSEN AS THE BEST STRAIGHT LINE FIT IN ORDER TO REDUCE THE MAXIMUM DEVIATIONS OF THE ACTUAL TRANSFER FUNCTION FROM THE REFERENCE.

THE MATHEMATICAL EQUATION DESCRIBING THE ACTUAL TRANSFER FUNCTION IS:

$$\frac{E_O}{E_1} = M \left(\frac{\Theta_W}{\Theta_A} \right) + b + k$$

WHERE M IS THE UNSPECIFIED SLOPE WHOSE VALUE IS CHOSEN TO MINIMIZE DEVIATIONS FOR A SPECIFIC POTENTIOMETER, B IS THE SPECIFIED INTERCEPT VALUE DETERMINED BY THE MINIMUM OUTPUT VOLTAGE RATIO SPECIFICATION, Θ_W IS WIPER POSITION, Θ_A IS THE ACTUAL ELECTRICAL TRAVEL FOR A SPECIFIC UNIT, AND K IS THE LINEARITY.

Here's How to Participate:

Beginning in May 1998, EDN has been publishing excerpts from Bourns' popular "Trimmer Primer" series and other material each month. To participate fully in the program, Bourns will send you a 3-ring binder to house your information, technical articles, white papers and more. To get started, order your binder or any materials you may not have received, contact us via:

*e-mail: techweb@bourns.com • FAX: (909) 781-5273 (North America); +41- 41 7685510 (Europe)
or the Bourns Web Site: www.bourns.com*



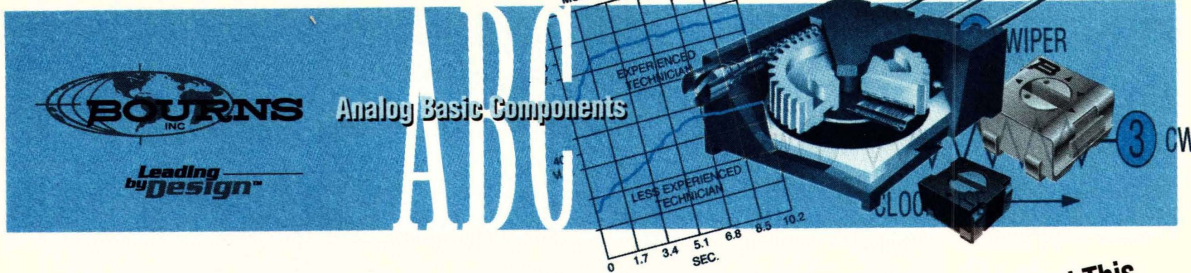

MORE CIRCUIT APPLICATIONS

IN ABOUT HALF THE RHEOSTAT APPLICATIONS, DESIGNERS USE THIS CONFIGURATION BY MAKING CONNECTIONS TO ONE END OF THE RESISTANCE ELEMENT AND THE WIPER, LEAVING THE OTHER ELEMENT TERMINAL OPEN AS SHOWN IN FIGURE A.

You Won't Find This
FREE
Info in Any Catalog!

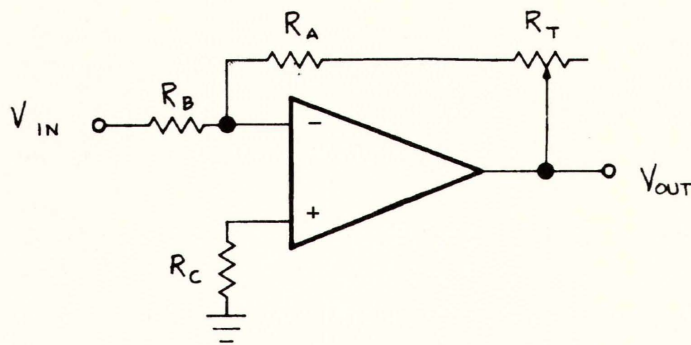
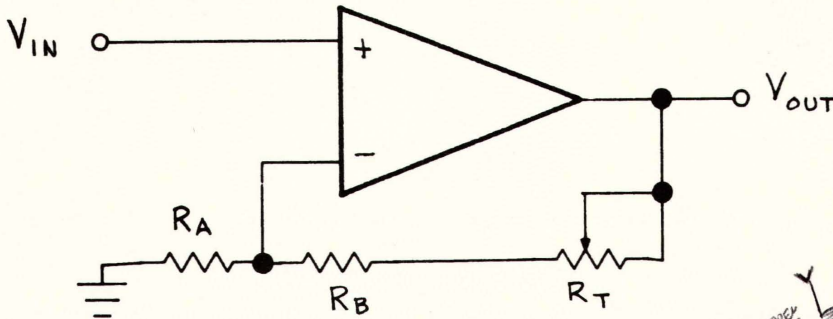
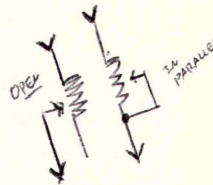

FIGURE A

✶ WHAT'S WRONG WITH THIS? WELL A COUPLE OF THINGS. TAKE A LOOK AT FIGURE B.



NON-INVERTING OP-AMP WITH FEEDBACK GAIN ADJUST
FIGURE B



✶ FIRST, NOTICE THAT THE UNUSED PORTION OF THE ELEMENT IS NOW IN PARALLEL WITH THE VARIABLE WIPER CONTACT RESISTANCE. THAT MEANS YOU COULD PICK UP SOME IMPROVEMENT IN CRV (CONTACT RESISTANCE VARIATION) DURING ADJUSTMENT AND SETTING STABILITY DURING STATIC OPERATION.

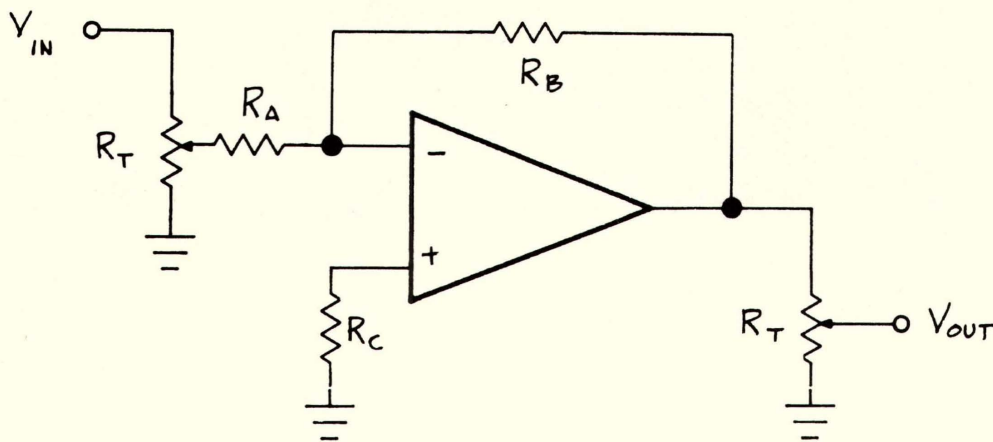

OP-AMP INPUT OR OUTPUT GAIN ADJUSTMENT
FIGURE C

SECOND, KEEP IN MIND THAT THE OPEN WIPER CONDITION IS THE MODE WHERE MOST TRIMMERS MEET THEIR DOWNFALL. IF THIS HAPPENS, THE OUTPUT IN BOTH EXAMPLES COULD BE FORCED TO THE EXTREME LIMITS PERMITTED BY THE SUPPLY VOLTAGES. AND THAT COULD DAMAGE OTHER COMPONENTS IN THE SYSTEM.

★ IF THE UNUSED PORTION OF THE TRIMMER ELEMENT IS TIED TO THE WIPER, THE OUTPUT OF BOTH CIRCUITS CAN ONLY SHIFT BY THE AMOUNT PERMITTED BY THE TOTAL TRIMMER RESISTANCE AND WHAT DOES THAT GET YOU? IMPROVED RELIABILITY IN BOTH CASES.

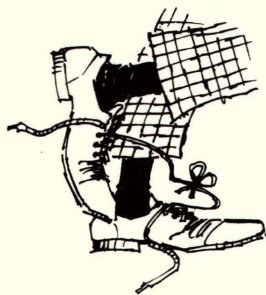

TAKE OUR ADVICE:
TIE UP YOUR LOOSE ENDS ON RHEOSTATS.

AND REMEMBER, ALWAYS USE THE SMALLEST VALUE OF TRIMMER RESISTANCE THAT WILL GIVE THE RANGE OF ADJUSTMENT NEEDED BY YOUR APPLICATION.

Here's How to Participate:

Beginning in May 1998, EDN has been publishing excerpts from Bourns' popular "Trimmer Primer" series and other material each month. To participate fully in the program, Bourns will send you a 3-ring binder to house your information, technical articles, white papers and more. To get started, order your binder or any materials you may not have received, contact us via:

e-mail: techweb@bourns.com • FAX: (909) 781-5273 (North America); +41- 41 7685510 (Europe)
or the Bourns Web Site: www.bourns.com



Leading
by Design™



Analogue Basic Components

ABC

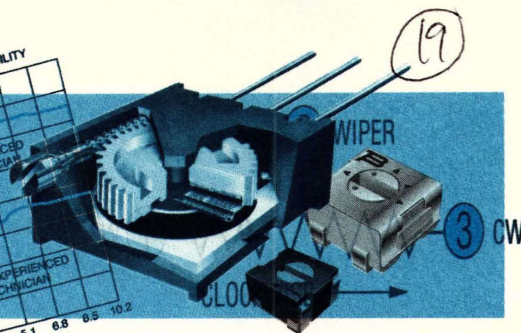

MORE CIRCUIT APPLICATIONS (Cont'd from previous issue)

You Won't Find This
FREE
Info in Any Catalog!

THERE SEEMS TO BE A TENDENCY FOR DESIGNERS TO USE THE TRIMMER TO SATISFY THE TOTAL RESISTANCE REQUIRED BY THAT LEG OF A SERIES NETWORK. YOU CAN SEE THAT IN FIGURES A AND D WHERE IT'S ASSUMED THAT ONLY A SMALL ADJUSTMENT OF FREQUENCY IS NEEDED. BUT A LARGER VALUE OF TRIMMER RESISTANCE IS USED TO AVOID AN ADDITIONAL FIXED RESISTANCE TO SET THE CENTER FREQUENCY. THAT'S A COMMON MISUSE OF THE TRIMMER.

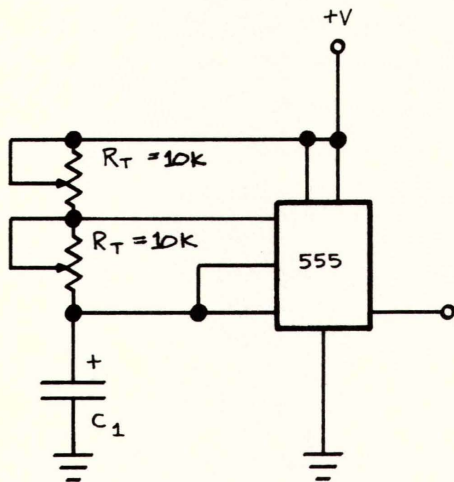

TYPICAL OSCILLATOR CIRCUIT
FIGURE A

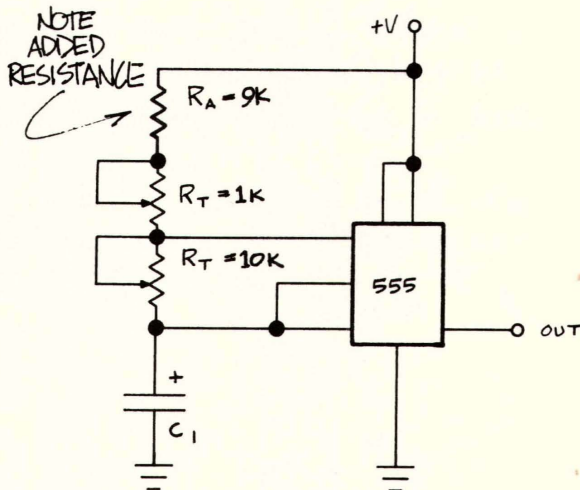

TYPICAL OSCILLATOR CIRCUIT
FIGURE B

WEIN BRIDGE OSCILLATOR
FIGURE C

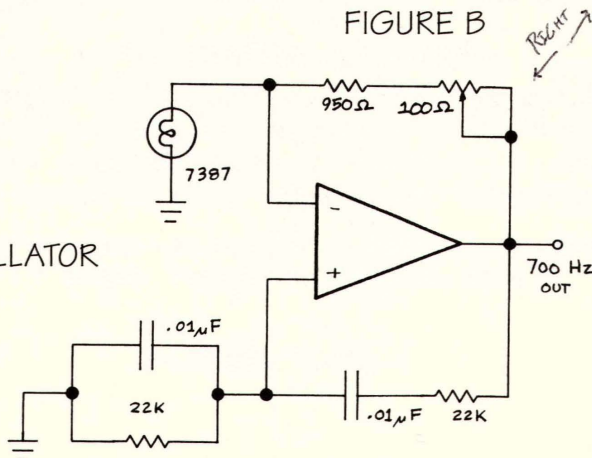

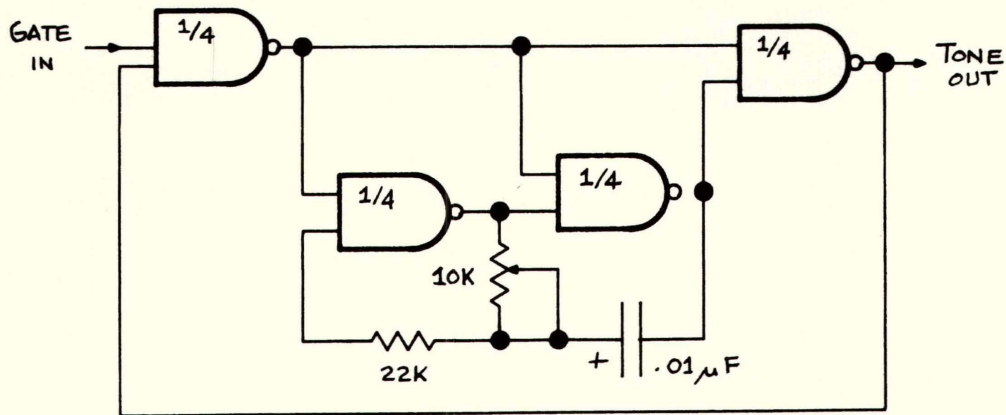

OSCILLATOR GATED TONE BURST OSCILLATOR
FIGURE D

DOING IT THAT WAY CAN SAVE YOU A FIXED RESISTOR OR TWO, BUT YOU'LL PAY THE COST OF REDUCED STABILITY AND DRIFT DUE TO THE POOR MATCH OF CHARACTERISTICS BETWEEN FIXED RESISTORS AND THE TRIMMER.

SO WHAT'S THE RIGHT WAY? LOOK AT FIGURES B AND C. FOR BEST PERFORMANCE, USE A SERIES FIXED RESISTANCE WITH THE TRIMMER TO PROVIDE ONLY THE RANGE OF ADJUSTMENT REQUIRED BY THE APPLICATION.

Here's How to Participate:

Beginning in May 1998, EDN has been publishing excerpts from Bourns' popular "Trimmer Primer" series and other material each month. To participate fully in the program, Bourns will send you a 3-ring binder to house your information, technical articles, white papers and more. To get started, order your binder or any materials you may not have received, contact us via:

e-mail: techweb@bourns.com • FAX: (909) 781-5273 (North America); +41- 41 7685510 (Europe)
or the Bourns Web Site: www.bourns.com



Leading
by Design™

advertisement

BOURNS INC. **ABC** Analog Basic Components
Leading by Design

MULTITURN SETTABILITY
EXPERIENCED TECHNICIAN
LESS EXPERIENCED TECHNICIAN
WIPER
CLOCK
21
3 CW

0 1.7 3.4 5.1 6.8 8.5 10.2 SEC.

BOARD WASHING

THIS PROCESS, DESIGNED TO REMOVE EXCESS FLUX AND CONTAMINANTS FROM THE BOARD, SUBJECTS THE COMPONENTS TO A TIDAL WAVE, CAUSING A SUDDEN TEMPERATURE DROP THAT IS EVEN MORE SHATTERING THAN THE SUDDEN RISE DURING SOLDERING. SHOCK! THINK OF A BLACKSMITH PLUNGING A HORSESHOE INTO A BUCKET OF WATER AND YOU GET AN IDEA OF THE SHOCK BOARD WASHING CAN GIVE THE CIRCUIT BOARD.

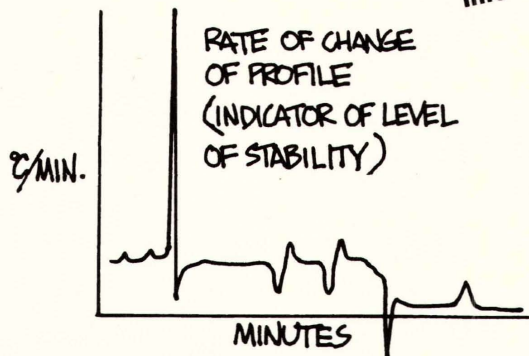

TYPICAL TEMPERATURE PROFILE FOR BOARD WASHING AND SOLDERING

THE WATER BATH COMMONLY USED FOR BOARD WASHING CAN LOWER AIR TEMPERATURE SO QUICKLY THAT A PARTIAL VACUUM IS CREATED THAT CAN SUCK IN CONTAMINANTS LIKE A VACUUM CLEANER.



TO HELP YOUR TRIMMERS SURVIVE PRINTED CIRCUIT BOARD PROCESSING:

FAN THEM -- USE A COOLING FAN TO DROP THE TEMPERATURE AFTER SOLDERING, BUT BEFORE THE UNITS ENTER THE WASH.

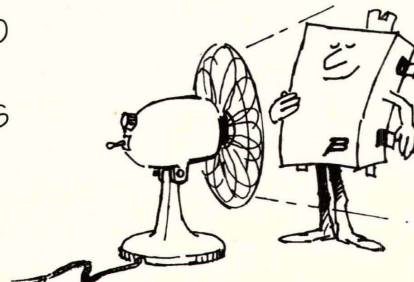

SLOW THEM -- ADD A SHORT DELAY BEFORE CLEANING, TO PROVIDE A COOLING TIME.

A FINAL CHECKLIST

- ~~X~~ TO MINIMIZE TEMPERATURE SHOCK OF SOLDERING, PREHEAT BOARDS AND REDUCE SOLDER TIME.
- TO AVOID HEATING COMPONENTS ABOVE MAX. TEMPERATURES, USE THE LOWEST POSSIBLE SOLDER TEMPERATURE AND THE MAXIMUM ALLOWABLE CONVEYOR SPEED CONSISTENT WITH GOOD SOLDERING PRACTICES.
- TO REDUCE SHOCK WHEN TRIMMERS HIT THE WASH, USE A WASH/RINSE TEMPERATURE CLOSE TO THE COMPONENT TEMPERATURE. EXTEND TIME BETWEEN THE SOLDER PROCESS AND THE WASH TO ALLOW COOLING OF THE BOARD AFTER SOLDER AND BEFORE THE WASH.
- AND TO MINIMIZE THE EFFECT OF MOISTURE, USE AS FEW WASH/RINSE AND RINSE/DRY CYCLES AS POSSIBLE, AND USE HEATED AIR KNIVES.
- TO REDUCE SHOCK WHEN TRIMMERS HIT THE WASH, USE A WASH/RINSE TEMPERATURE COMPONENT CLOSE TO THE COMPONENT TEMPERATURE. EXTEND TIME BETWEEN THE SOLDER PROCESS AND THE WASH TO ALLOW COOLING OF THE BOARD AFTER SOLDER AND BEFORE THE WASH.

Here's How to Participate:

Beginning in May 1998, EDN has been publishing excerpts from Bourns' popular "Trimmer Primer" series and other material each month. To participate fully in the program, Bourns will send you a 3-ring binder to house your information, technical articles, white papers and more. To get started, order your binder or any materials you may not have received, contact us via:

*e-mail: techweb@bourns.com • FAX: (909) 781-5273 (North America); +41- 41 7685510 (Europe)
or the Bourns Web Site: www.bourns.com*



**Leading
by design™**

advertisement

BOURNS INC. **Leading by Design™**

ABC Analog Basic Components

MULTITURN SETTABILITY

EXPERIENCED TECHNICIAN

LESS EXPERIENCED TECHNICIAN

WIPER

3 CW

SEC. 0 1.7 3.4 5.1 6.8 8.5 10.2

THE MECHANICAL MENACE

CONSIDER WHICH OF THESE COMMON PRODUCTION-LINE HAZARDS THE TRIMMER WILL HAVE TO ENDURE AND SELECT A PRODUCT THAT'S SUITABLE TO THE CHALLENGE.

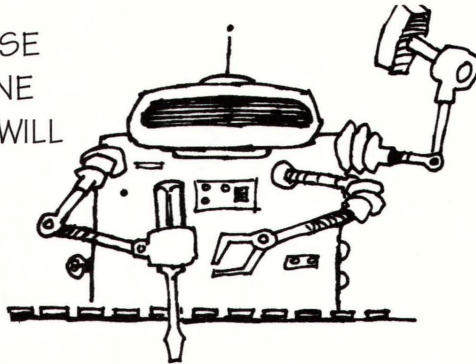

You Won't Find This
FREE
Info in Any Catalog!

- AUTO INSERTION - IF THE TRIMMERS WILL BE INSERTED BY MACHINE, SELECT MODELS THAT HAVE TERMINATIONS STRONG ENOUGH TO WITHSTAND THE FORCES.

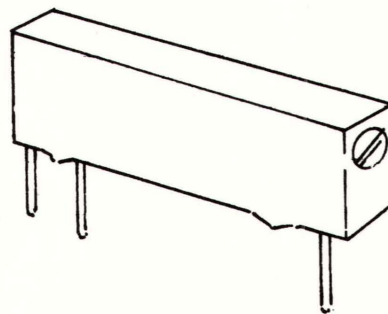
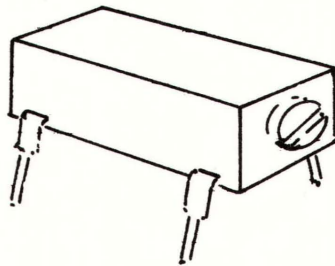

- AUTOMATIC TRIMMER ADJUSTMENT-ROBOTIC EQUIPMENT IS NOW AVAILABLE THAT CAN MEASURE CIRCUIT PARAMETERS AND MAKE NECESSARY TRIMMER ADJUSTMENTS AUTOMATICALLY.

IF YOU HAVE REQUIREMENTS FOR VERY HIGH-VOLUME PRODUCTION, YOU MAY WANT TO SUGGEST THIS EQUIPMENT FOR YOUR COMPANY. SELECT A TRIMMER THAT HAS AN ADJUSTMENT SCREW HEAD THAT IS COMPATIBLE WITH ROBOTIC EQUIPMENT, TYPICALLY A CROSS SLOT OR A HEX SHAPED DRIVE FEATURE.

- ADJUSTMENT SCREW HEAD CEMENTING - A MULTI-TURN TRIMMER ~~ADJUSTMENT SCREW IS SELF-LOCKING~~. EVEN WHERE THE UNIT WILL BE SUBJECTED TO VIBRATION OR SHOCK, THERE IS RARELY A NEED TO CEMENT THE ADJUSTMENT SCREW IN POSITION. IN MOST APPLI- CATIONS, THE ONLY REASONS TO DO SO WOULD BE TO PREVENT THE USER FROM MAKING ADJUSTMENTS, OR TO TELL IF AN UNAUTHORIZED ADJUSTMENT HAS BEEN MADE.

- TRIMMER LOCATION - YOU'VE HEARD OF A POT HANDLE? IF YOU PUT THE POT IN THE WRONG PLACE ON YOUR BOARD, PEOPLE WILL USE IT AS A HANDLE FOR PICKING UP THE BOARD. KEEP THIS HAZARD IN MIND WHEN LAYING OUT YOUR BOARD.

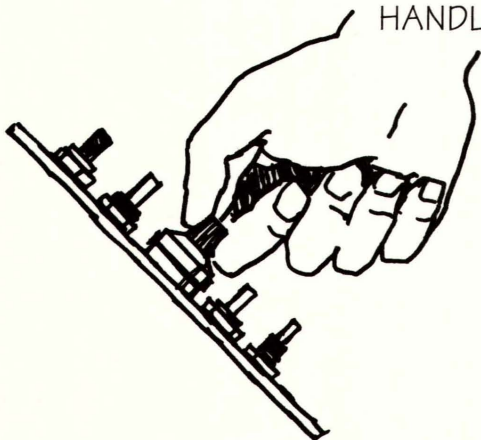

Here's How to Participate:

Beginning in May 1998, EDN has been publishing excerpts from Bourns' popular "Trimmer Primer" series each month. To participate fully in the program, Bourns will send you a 3-ring binder to house your information, technical articles, white papers and more. To get started, order your binder or any materials you may not have received, contact us via:

*e-mail: techweb@bourns.com • FAX: (909) 781-5273 (North America); +41- 41 7685510 (Europe)
or the Bourns Web Site: www.bourns.com*



**Leading
by Design™**

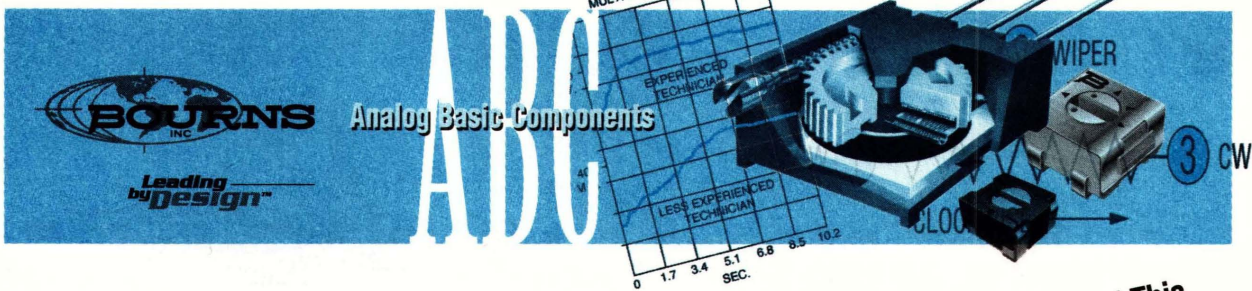

THE OPERATING ENVIRONMENT OF THE FINAL PRODUCT

You Won't Find This
FREE
Info in Any Catalog!

IN SELECTING THE RIGHT TRIMMER FOR THE JOB, YOU NEED TO CONSIDER THE ENVIRONMENT IN WHICH THE PRODUCT YOU'RE BUILDING WILL ULTIMATELY BE USED. THERE ARE SOME FACTORS IN THIS EVALUATION THAT ARE OFTEN OVERLOOKED.

- WHERE ACCURACY OF TOTAL RESISTANCE OVER A RANGE OF TEMPERATURES IS IMPORTANT, A WIREWOUND UNIT MAY BE THE CHOICE. THE TEMPCO FOR WIREWOUND IS GENERALLY ± 50 PPM/°C WHEN MEASURED BETWEEN THE ENDS OF THE ELEMENT.
- HUMIDITY IS A PARTICULAR PROBLEM FOR CARBON TRIMMERS, DUE TO THE HYDROSCOPIC NATURE OF THE MATERIAL. IN SEALED TRIMMERS, CERMET AND WIREWOUND UNITS ARE RARELY AFFECTED. IN FACT, ALL MODELS ROUTINELY PASS THE STRINGENT REQUIREMENTS OF MILITARY SPECIFICATIONS.
- LONG-TERM POWER – THE WAY POWER IS APPLIED CAN HAVE A SIGNIFICANT EFFECT ON THE LIFE AND FUNCTIONING OF THE TRIMMER. AMONG THE FACTORS TO CONSIDER: WILL THE TRIMMER BE USED IN AN AC APPLICATION OR A DC? IS HIGH FREQUENCY AC REACTANCE A CONSIDERATION? WILL THE POWER BE ON CONTINUOUSLY FOR LONG PERIODS OF TIME? WILL THE POWER BE CYCLED ON AND OFF REPEATEDLY? ARE MULTIPLE UNITS “STACKED” SIDE-BY-SIDE? WHAT IS THE MAXIMUM AMBIENT TEMPERATURE THE TRIMMER WILL BE SUBJECTED TO?



TRANSPORT – EVEN IF YOUR PRODUCT IS NOT A PORTABLE OR MOBILE PIECE OF EQUIPMENT, DON'T OVERLOOK THE FACT THAT IT WILL BE SUBJECTED TO THE RIGORS OF SHIPPING BEFORE IT REACHES YOUR CUSTOMER. TAKE INTO ACCOUNT THE EXTREMES OF TEMPERATURE, SHOCK AND VIBRATION THAT MIGHT BE ENCOUNTERED.



Here's How to Participate:

Beginning in May 1998, EDN has been publishing excerpts from Bourns' popular "Trimmer Primer" series each month. To participate fully in the program, Bourns will send you a 3-ring binder to house your information, technical articles, white papers and more. To get started, order your binder or any materials you may not have received, contact us via:

*e-mail: techweb@bourns.com • FAX: (909) 781-5273 (North America); +41- 41 7685510 (Europe)
or the Bourns Web Site: www.bourns.com*



**Leading
by Design™**

advertisement

BOURNS INC. **ABC** Analog Basic Components
Leading by Design

MULTITURN SETTABILITY
EXPERIENCED TECHNICIAN
LESS EXPERIENCED TECHNICIAN
SEC. 0 1.7 3.4 5.1 6.8 8.5 10.2

WIPER
24
3 CW
CLOCK

THE POSSIBILITIES OF SMT

You Won't Find This
FREE
Info in Any Catalog!

BEFORE WE START THE HEAVY-DUTY WORK, LET'S EASE INTO A LITTLE "WHAT IF" DAYDREAMING.

WHAT IF YOU COULD BOOST THE PERFORMANCE OF YOUR CIRCUIT BY 10%, 15%, 20% OR MORE?



WHAT IF YOU COULD SIMULTANEOUSLY REDUCE NOISE AND CROSSTALK AND GET IMPROVED EMI/RFI CHARACTERISTICS AS WELL?

WHAT IF THESE PERFORMANCE INCREASES CAME WITH A CORRESPONDING DECREASE IN BOARD SIZE LEADING TO A SMALLER CHASSIS LEADING TO A MORE COMPACT PRODUCT?

WHAT IF BOARD ASSEMBLY TIME WAS REDUCED, REWORK VIRTUALLY ELIMINATED AND FIELD FAILURES SO RARE THEY BECOME A CURIOSITY?

WHAT IF IT WASN'T A DAYDREAM? WHAT IF ALL YOUR COMPETITORS HAD SUCH TECHNOLOGY AND IF YOU DIDN'T GET IT SOON THE MARKET WAS GOING TO GIVE YOU "WHAT FOR."

THAT'S ABOUT WHERE SMT IS TODAY.

LET'S TAKE A LOOK BELOW THE SURFACE OF SMT TO UNDERSTAND HOW AND WHY IT OFFERS SUCH BENEFITS.

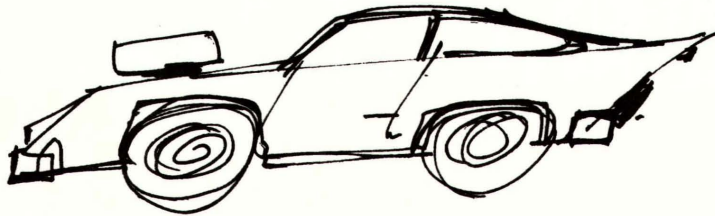

TURBO-CHARGED PERFORMANCE. PERFORMANCE INCREASES RESULT FROM GREATER COMPONENT DENSITY (THE DISTANCE BETWEEN COMPONENTS) AND REDUCTION OR ELIMINATION OF LEAD LENGTH BETWEEN THE COMPONENT AND THE BOARD.

THERE IS SIGNIFICANTLY LESS TRACE RESISTANCE, LESS TRACE INDUCTANCE AND A REDUCTION IN LINE CAPACITANCE WITH SMT.

THESE SHORTER INTERCONNECTIONS RESULT IN IMPROVED EMI/RFI CHARACTERISTICS TOO. FOR YOU BUZZ WORD LOVERS OUT THERE, IT'S ENOUGH TO SAY THAT THE PACKAGE PARASITICS ARE REDUCED AND THERE'S AN "INDUCTIVE REDUCTION FOR SPEED PRODUCTION."

Here's How to Participate:

Beginning in May 1998, EDN has been publishing excerpts from Bourns' popular "Trimmer Primer" series each month. To participate fully in the program, Bourns will send you a 3-ring binder to house your information, technical articles, white papers and more. To get started, order your binder or any materials you may not have received, contact us via:

*e-mail: techweb@bourns.com • FAX: (909) 781-5273 (North America); +41- 41 7685510 (Europe)
or the Bourns Web Site: www.bourns.com*



**Leading
by Design™**

RESISTIVE ELEMENTS

You Won't Find This
FREE
Info in Any Catalog!

THE REAL HEART OF ANY POTENTIOMETER IS THE RESISTIVE ELEMENT. IT AFFECTS, TO SOME DEGREE, ALL POTENTIOMETER ELECTRICAL PARAMETERS. THERE ARE TWO GENERAL CLASSIFICATIONS OF RESISTIVE ELEMENTS -- WIREWOUND AND NONWIREWOUND. THE NONWIREWOUND GROUP CAN BE FURTHER CLASSIFIED AS CERMET, CARBON, METAL FILM, OR BULK

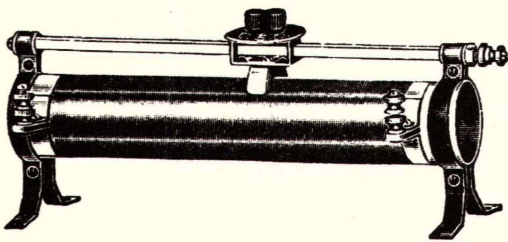

Early 20th century slide-wire rheostat
(Central Scientific Co.)

METAL. IT IS ALSO POSSIBLE TO COMBINE WIREWOUND AND CONDUCTIVE PLASTIC (A SPECIAL CARBON COMPOSITION) IN ONE ELEMENT TO ACHIEVE IMPROVED PERFORMANCE OF CERTAIN ELECTRICAL PARAMETERS. IN ADDITION, CERMET AND CONDUCTIVE PLASTIC HAVE BEEN COMBINED. BOTH OF THESE COMBINATION ELEMENTS ARE REFERRED TO AS HYBRID ELEMENTS.

WIREWOUND ELEMENTS

RESISTANCE WIRE CAN BE USED TO FORM THE RESISTIVE ELEMENT IN A POTENTIOMETER. COMMONLY USED MATERIALS ARE ONE OF THREE ALLOYS: NICKEL-CHROMIUM, COPPER-NICKEL, AND GOLD-PLATINUM.

BASICALLY, THE ACTUAL WIRE USED DEPENDS UPON THE TOTAL RESISTANCE REQUIRED, THE RESOLUTION NEEDED, AND THE SPACE AVAILABLE. SMALLER WIRE ALLOWS HIGHER RESISTANCE IN A GIVEN SPACE AND IMPROVED RESOLUTION. HOWEVER, SMALLER WIRE IS MORE FRAGILE AND THEREFORE, DIFFICULT TO WIND. POWER AND CURRENT CARRYING REQUIREMENTS ALSO INFLUENCE THE CHOICE OF RESISTANCE WIRE SIZE.

ALTHOUGH IT IS POSSIBLE TO HAVE A SIMPLE SINGLE STRAIGHT WIRE ELEMENT, SUCH CONSTRUCTION IS IMPRACTICAL. AS AN ILLUSTRATION, ASSUME THE HIGHEST RESISTIVITY WIRE WAS USED TO CONSTRUCT A 5000 OHM RESISTIVE ELEMENT. THE FINISHED POTENTIOMETER WOULD BE GREATER THAN ONE FOOT IN LENGTH. THE COMMON CONSTRUCTION TECHNIQUE FOR A RESISTIVE WIRE ELEMENT

REQUIRES MANY TURNS OF RESISTANCE WIRE CAREFULLY WOUND ON A CARRIER FORM OR MANDREL. THIS METHOD ALLOWS A SUBSTANTIAL RESISTANCE TO BE PACKAGED IN A SMALL VOLUME. THE MOST COMMON TYPE OF MANDREL IS A LENGTH OF INSULATED COPPER WIRE. AFTER WINDING, THIS FLEXIBLE CARRIER FORM CAN BE COILED IN A HELICAL FASHION TO FURTHER COMPRESS THE LENGTH REQUIRED FOR THE RESISTIVE ELEMENT.

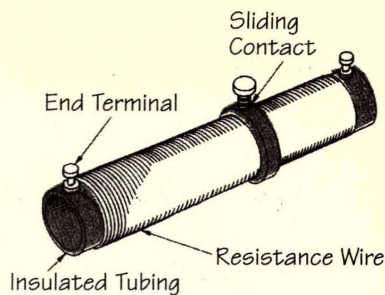

Winding resistance wire on insulated tube allows longer wire in a practical package

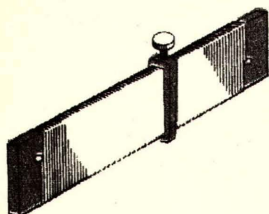

a flat mandrel could be used

THIS ELEMENT MAY BE CUT INTO INDIVIDUAL RINGS FOR SINGLE TURN POTENTIOMETERS OR HELICAL ELEMENTS FOR MULTITURN UNITS. THE VERY DELICATE RESISTANCE WIRE MUST BE WOUND ON THE MANDREL IN A MANNER THAT PRODUCES UNIFORMITY AND THE RIGHT AMOUNT OF TOTAL RESISTANCE IN THE EXACT LENGTH REQUIRED.

WIREWOUND POTENTIOMETERS OFFER VERY GOOD STABILITY OF TOTAL RESISTANCE WITH TIME AND TEMPERATURE CHANGES. STABILITY CAN BE BETTER THAN 0.01% IN 1000 HOURS OF OPERATION. ADDITIONALLY, THESE ELEMENTS OFFER LOW NOISE IN THE STATIC STATE, HIGH POWER CAPABILITIES, AND GOOD OPERATIONAL LIFE.

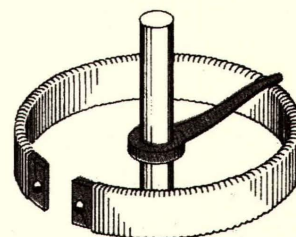

Curved mandrel saves space and allows rotary control

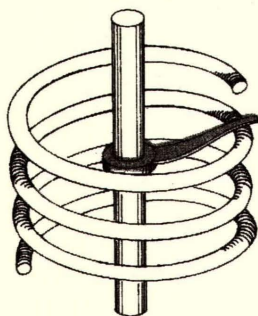

Shaping mandrel into helix puts long length in small space

WIREWOUND ELEMENTS DO NOT OFFER AS WIDE A SELECTION OF TR VALUES AS SOME OTHER TYPES; BUT, THE RANGE IN TRIMMERS IS FROM 10 OHMS TO 20K OHMS. SOME MANUFACTURERS OFFER VALUES AS HIGH AS 100K OHMS AT PREMIUM PRICES. PRECISIONS ARE AVAILABLE WITH TOTAL RESISTANCE AS LOW AS 25 OHMS AND AS HIGH AS 500K OHMS.

To be continued

Here's How to Participate:

Beginning in May 1998, EDN has been publishing excerpts from Bourns' popular "Trimmer Primer" series each month. To participate fully in the program, Bourns will send you a 3-ring binder to house your information, technical articles, white papers and more. To get started, order your binder or any materials you may not have received, contact us via:

e-mail: techweb@bourns.com • FAX: (909) 781-5273 (North America); +41- 41 7685510 (Europe)
or the Bourns Web Site: www.bourns.com



Leading
by Design™

BOURNS INC. *Leading by Design*

ABC Analog Basic Components

MULTITURN SETTABILITY

EXPERIENCED TECHNICIAN

LESS EXPERIENCED TECHNICIAN

WIPER

3 CW

0 1.7 3.4 5.1 6.8 8.5 10.2 SEC.

RESISTIVE ELEMENTS (Cont'd from previous issue)

You Won't Find This
FREE
Info in Any Catalog!

THE USE OF WIREWOUND ELEMENTS SHOULD BE AVOIDED IN HIGH FREQUENCY APPLICATIONS. THE MANY TURNS OF RESISTANCE WIRE EXHIBIT AN INDUCTIVE REACTANCE WHICH INCREASES DIRECTLY WITH FREQUENCY. THIS EFFECT IS MOST NOTICEABLE IN LOW TOTAL RESISTANCE POTENTIOMETERS BECAUSE THE INDUCTIVE REACTANCE CAN BE LARGER THAN THE RESISTANCE, EVEN AT FREQUENCIES AS LOW AS 20KHZ.

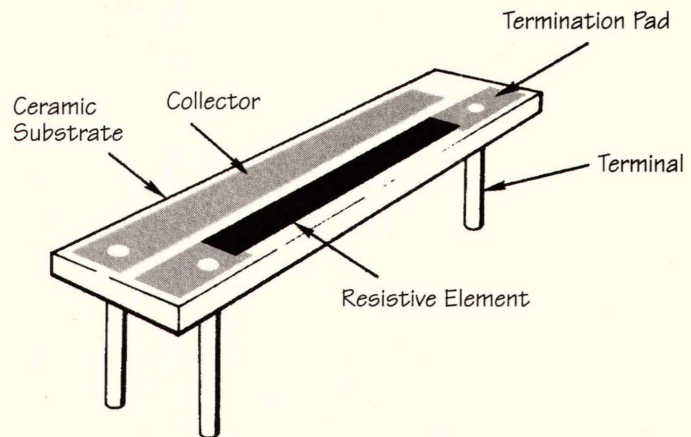

A common cermet potentiometer construction

PERFORMANCE OF WIREWOUND POTENTIOMETERS IS ALSO AFFECTED BY INHERENT CAPACITANCE. CAPACITANCE EXISTS FROM TURN TO TURN AND ALSO BETWEEN THE WINDING AND MANDREL. CAPACITANCE EFFECTS ARE MOST SIGNIFICANT IN HIGH TOTAL RESISTANCE POTENTIOMETERS THAT USUALLY HAVE MORE TURNS OF WIRE.

NONWIREWOUND ELEMENTS

VARIABLE RESISTIVE DEVICES THAT ARE NOT MADE WITH RESISTANCE WIRE ARE CATEGORIZED BY THE INDUSTRY AND MILITARY AS NONWIREWOUND.

CERMET RESISTIVE ELEMENTS. ONE OF THE MATERIALS DEVELOPED COMBINES VERY FINE PARTICLES OF CERAMIC OR GLASS WITH THOSE OF PRECIOUS METALS TO FORM A CERAMIC METAL RESISTIVE MATERIAL AFTER FIRING IN A KILN. CERMET IS A TERM WHICH MAY BE APPLIED TO A WIDE RANGE OF MATERIALS AS MANUFACTURED BY DIFFERENT SOURCES. DO NOT ASSUME THAT ALL CERMET POTENTIOMETERS ARE THE SAME. THE COMMENTS INCLUDED IN THE FOLLOWING PARAGRAPHS APPLY TO CERMET ELEMENTS MADE BY MOST MANUFACTURERS.

MAJOR MANUFACTURERS PAINSTAKINGLY COMPOUND, AND CAREFULLY CONTROL, THE COMPOSITION OF THEIR CERMET MATERIALS AND PROCESSES. THESE ARE USUALLY CONSIDERED PROPRIETARY FOR COMPETITIVE REASONS SO EXACT MATERIALS AND DETAILS OF MANUFACTURING TECHNIQUES ARE OFTEN CLOSELY GUARDED.

CERMET, ALSO KNOWN AS THICK FILM, IS DEFINED AS RESISTIVE AND CONDUCTIVE FILMS GREATER THAN .0001 INCH THICK, RESULTING FROM FIRING A PASTE OR INK THAT HAS BEEN DEPOSITED ON A CERAMIC SUBSTRATE. SIMILAR MATERIALS AND TECHNIQUES ARE USED TO MANUFACTURE HYBRID CIRCUITS AND FIXED RESISTOR NETWORKS. FOR POTENTIOMETERS, THE CONDITION OF THE SURFACE OF THE FILM RELATIVE TO WIPER ACTION (CONDUCTIVITY AND ABRASIVENESS) IS A MAJOR CONCERN.

THE PASTE IS APPLIED TO A FLAT CERAMIC SUBSTRATE, USUALLY ALUMINA OR STEATITE, BY A SILK SCREENING OPERATION. THIS IS A MECHANIZED PRECISION STENCILING PROCESS WHICH USES SCREENS OF STAINLESS STEEL OR NYLON. THE INK IS FORCED THROUGH THE SCREEN BY A HARD RUBBER SQUEEGEE.

THE SHAPE OF THE ELEMENT IS CONTROLLED BY SMALL OPENINGS IN THE FINE MESH SCREEN THAT CORRESPOND TO THE DESIRED PATTERN. THE PATTERN OF THE SCREEN OPENINGS IS PRODUCED BY A PHOTOGRAPHIC PROCESS FROM A LARGE SCALE ARTWORK MASTER. THIS PROCESS ALLOWS GREAT VERSATILITY AND PROVIDES HIGH PRECISION IN SCREEN PRODUCTION.

COMPOSITION OF THE RESISTIVE INKS VARIES ACCORDING TO DESIRED RESULTS. THEY ALL CAN BE DESCRIBED AS BEING COMPOSED OF FINELY POWERED INORGANIC SOLIDS (METAL AND METAL OXIDES) MIXED WITH A POWERED GLASS BINDER (GLASS FRIT) AND SUSPENDED IN A ORGANIC VEHICLE (A RESIN MIXTURE). MATERIALS USED INCLUDING SILVER, PALLADIUM, PLATINUM, RUTHENIUM, RHODIUM, AND GOLD.

To be continued

Here's How to Participate:

Beginning in May 1998, EDN has been publishing excerpts from Bourns' popular "Trimmer Primer" series each month. To participate fully in the program, Bourns will send you a 3-ring binder to house your information, technical articles, white papers and more. To get started, order your binder or any materials you may not have received, contact us via:

*e-mail: techweb@bourns.com • FAX: (909) 781-5273 (North America); +41- 41 7685510 (Europe)
or the Bourns Web Site: www.bourns.com*



**Leading
by Design™**

28

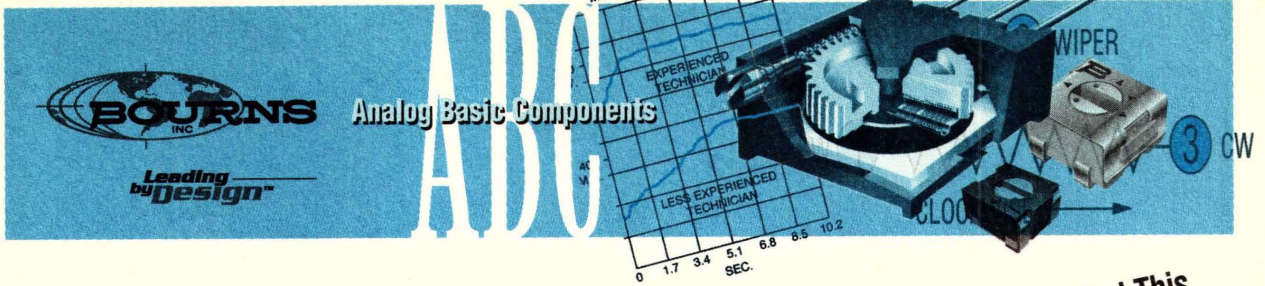

RESISTIVE ELEMENTS (Cont'd from previous issue)

You Won't Find This
FREE
Info in Any Catalog!

PRINTING AND FIRING OF THE INKS IS PREFERABLY DONE IN A HUMIDITY AND TEMPERATURE CONTROLLED ENVIRONMENT. A CONTROLLED TEMPERATURE KILN WITH VARIOUS TEMPERATURE ZONES BETWEEN 800°C AND 1200°C IS USED TO BURN OFF THE ORGANIC VEHICLE AND CAUSES A FUSION OF THE GLASS PARTICLES WITH THE CERAMIC SUBSTRATE. THE METALLIC PARTICLES PROVIDE A RESISTIVE FILM WHICH IS BONDED TO THE SUBSTRATE.

A VERY WIDE RANGE IN RESISTANCE VALUES CAN BE ACHIEVED BY VARYING:

- 1) THE COMPOSITION OF THE RESISTIVE INK.
- 2) THE FIRING PARAMETERS (TIME AND TEMPERATURE).
- 3) THE PHYSICAL SIZE OF THE ELEMENT.

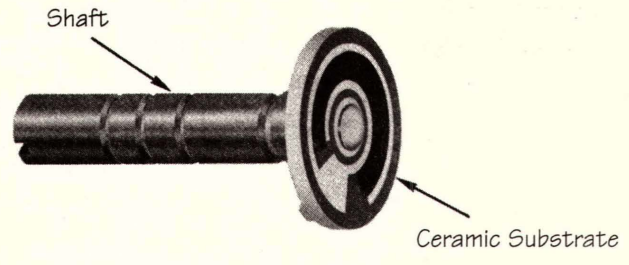

In this design, a ceramic substrate is attached directly to the shaft in order to increase power dissipation capability

SELECTION FACTORS. POTENTIOMETERS HAVING A TOTAL RESISTANCE FROM 10 OHMS TO 10 MEGOHMS ARE PRACTICAL. HOWEVER, THE ENTIRE RESISTANCE RANGE IS NOT AVAILABLE IN ALL POSSIBLE SIZES AND CONFIGURATIONS.

★ CERMET ELEMENTS OFFER VERY LOW (INFINITISIMAL) RESOLUTION AND GOOD STABILITY. THEIR NOISE PERFORMANCE IS GOOD IN BOTH THE STATIC AND DYNAMIC (CRY) CONDITION.

FREQUENCY RESPONSE OF CERMET MATERIALS IS VERY GOOD AND THE PRACTICAL APPLICATION RANGE EXTENDS WELL BEYOND 100MHZ. THE LOWER RESISTIVITY MATERIALS EXHIBIT AN EQUIVALENT SERIES INDUCTANCE, WHILE THE HIGHER RESISTANCE CERMETS DISPLAY AN EQUIVALENT SHUNT CAPACITANCE.

OPERATIONAL LIFE OF CERMET ELEMENTS IS EXCELLENT. THE ELEMENT SURFACE IS HARD AND VERY DURABLE. FAILURES OF CERMET POTENTIOMETERS, AFTER EXTENDED MECHANICAL OPERATION, ARE MORE OFTEN WIPER FAILURES DUE TO WEAR THAN PROBLEMS IN THE ELEMENT.

FOR TRIMMING APPLICATIONS, CERMET ELEMENTS USUALLY OFFER THE BEST PERFORMANCE PER DOLLAR PER UNIT SPACE. EVEN THOUGH CERMET ELEMENTS ARE MORE ABRASIVE THAN CONDUCTIVE PLASTIC, WIPER WEAR IS LOW ENOUGH THAT MECHANICAL LIFE FAR EXCEEDS TRIMMER REQUIREMENTS.

CARBON ELEMENTS. EARLY CARBON FILM POTENTIOMETERS WERE USUALLY MADE WITH A MIXTURE OF CARBON POWDER AND PHENOLIC RESIN APPLIED TO A PHENOLIC SUBSTRATE AND CURED. DRAMATIC IMPROVEMENTS IN MATERIALS TECHNOLOGY OVER THE YEARS HAVE RESULTED IN AN UPGRADING OF SUBSTRATES AND CARBON-PLASTIC RESIN COMPOUNDS. ONE EARLY IMPROVEMENT WAS THE USE OF CERAMIC AS A SUBSTRATE FOR ELEMENTS MADE OF CARBON AND PHENOLIC RESIN.

DEPENDING ON DESIRED END RESULTS, A CARBON COMPOSITION ELEMENT MAY BE SCREENED ON (AS WITH CERMET), BRUSHED ON, SPRAYED ON, APPLIED WITH A TRANSFER WHEEL, OR DIPPED ONTO AN INSULATIVE SUBSTRATE. WHEN SPRAYED ONTO A SUBSTRATE, AN AUTOMATICALLY CONTROLLED SPRAY GUN IS SWEEPED BACK AND FORTH. CONTROLLING THE SWEEP SPEED DETERMINES THE THICKNESS OF THE RESISTIVE MATERIAL WHICH INFLUENCES THE RESISTIVITY OF THE ELEMENT. A MASK (STENCIL) MAY BE USED TO CONTROL THE RESISTIVE PATTERN.

THE PROCESSING OF ALL NONWIREWOUND ELEMENTS REQUIRES A MANUFACTURING ENVIRONMENT WHICH IS FREE FROM DUST AND OTHER FOREIGN PARTICLES. FOREIGN PARTICLES SETTLING ON A WET RESISTIVE FILM WILL INTERFERE WITH STABILITY, CONTACT RESISTANCE VARIATION AND THE ELEMENT'S TOTAL RESISTANCE.

To be continued

Here's How to Participate:

Beginning in May 1998, EDN has been publishing excerpts from Bourns' popular "Trimmer Primer" series each month. To participate fully in the program, Bourns will send you a 3-ring binder to house your information, technical articles, white papers and more. To get started, order your binder or any materials you may not have received, contact us via:

*e-mail: techweb@bourns.com • FAX: (909) 781-5273 (North America); +41- 41 7685510 (Europe)
or the Bourns Web Site: www.bourns.com*



RESISTIVE ELEMENTS (Cont'd from previous issue)

You Won't Find This
FREE
Info in Any Catalog!

AFTER THE RESISTIVE MATERIAL IS APPLIED TO THE SUBSTRATE, THE RESISTANCE ELEMENTS ARE TRANSFERRED TO AN OVEN FOR CURING. THE PROCEDURE MAY BE DONE BY STATIC OVEN BATCH CURING OR BY INFRARED

CURING. DURING CURING, THE SOLVENTS ARE DRIVEN OFF AND THE ORGANIC RESIN CROSS LINKS TO FORM A DURABLE PLASTIC FILM. THE RESISTIVITY INCREASES WITH TIME OR TEMPERATURE. THIS INCREASE IN RESISTIVITY IS PREDICTABLE AND MAY BE COMPENSATED FOR DURING PREPARATION OF THE CARBON COMPOSITION MATERIAL. THE FINISHED ELEMENT HAS CHARACTERISTICS SIMILAR TO A CARBON-FILM FIXED RESISTOR.

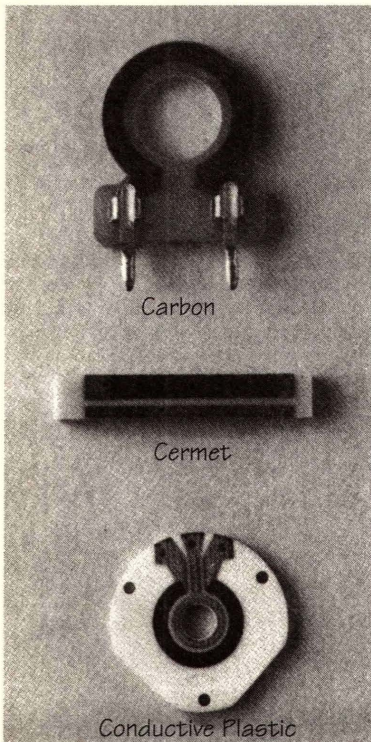

Resistive elements of composition materials

VARIOUS TECHNIQUES ARE AVAILABLE FOR CHANGING THE RESISTIVITY OF THE ELEMENTS. IN ADDITION TO THE AMOUNT OF CARBON, SMALL QUANTITIES OF POWDERED METALS, SUCH AS SILVER, ARE SOMETIMES USED. THE METALS, BEING CONDUCTORS, LOWER THE RESISTIVITY AND CAUSE THE TEMPERATURE COEFFICIENTS TO BECOME MORE POSITIVE. ALTERING THE ELEMENT GEOMETRY AND PLACING SHORTING CONDUCTORS UNDER THE ELEMENT ARE TWO OTHER METHODS WHICH MAY BE USED TO CHANGE THE RESISTIVITY.

POTENTIOMETERS MADE WITH MOLDED CARBON ARE MANUFACTURED BY MOLDING A PREVIOUSLY FORMED RESISTANCE ELEMENT AND OTHER PARTS OF THE POTENTIOMETER TOGETHER. THESE MOLDED UNITS ARE SOMETIMES CALLED HOT MOLDED CARBON AND ARE COMPARABLE TO THE CARBON-PELLET TYPE OF FIXED RESISTORS. THE HOT MOLDED CARBON ELEMENT PROVIDES DEFINITE IMPROVEMENTS IN MECHANICAL LIFE AND TC COMPARED TO ORDINARY CARBON FILM ELEMENTS.

CONDUCTIVE PLASTIC, THE MODERN CARBON FILM ELEMENT, IS MADE WITH ONE OF THE MORE RECENT PLASTIC RESINS SUCH AS EPOXY, POLYESTERS, IMPROVED PHENOLICS, OR POLYAMIDES. THESE RESINS ARE BLENDED WITH CAREFULLY PROCESSED CARBON POWDER AND APPLIED TO CERAMIC OR GREATLY IMPROVED PLASTIC SUBSTRATES. THE RESULT IS SUPERIOR STABILITY AND PERFORMANCE. THE IMPORTANCE OF PLASTICS TECHNOLOGY TO THESE IMPROVEMENTS HAS PROBABLY BEEN THE REASON FOR ACCEPTANCE OF THE TERM CONDUCTIVE PLASTIC OR PLASTIC FILM ELEMENT.

CONDUCTIVE PLASTIC ELEMENTS MAY VARY CONSIDERABLY IN TEMPERATURE COEFFICIENT (TC). THE RESISTIVITY RANGE, AMBIENT TEMPERATURE RANGE, MATERIALS PREPARATION PROCEDURES, SUBSTRATE MATERIAL, AND THE CURING TECHNIQUES ALL INFLUENCE THE TC QUALITY.

THE SUBSTRATES USED MAY BE EITHER CERAMIC OR PLASTIC; HOWEVER, MODERN PLASTIC SUBSTRATES RESULT IN BETTER TEMPERATURE COEFFICIENTS DUE TO THE GREATER COMPATIBILITY OF THE INK AND THE SUBSTRATE.

FOR THINNER FILMS THAN THOSE OBTAINED WITH APPLICATION METHODS MENTIONED ABOVE, CARBON MAY BE APPLIED BY VAPOR DEPOSITION. THIS METHOD, WHILE YIELDING AN EXCELLENT FIXED RESISTOR, RESULTS IN A FILM THAT IS USUALLY TOO THIN TO WITHSTAND WIPER ABRASION.

CONDUCTIVE PLASTIC MATERIAL MAY ALSO BE DEPOSITED ON AN INSULATED METAL MANDREL AND FORMED IN A HELIX FOR USE IN MULTI-TURN POTENTIOMETERS.

To be continued

Here's How to Participate:

Beginning in May 1998, EDN has been publishing excerpts from Bourns' popular "Trimmer Primer" series each month. To participate fully in the program, Bourns will send you a 3-ring binder to house your information, technical articles, white papers and more. To get started, order your binder or any materials you may not have received, contact us via:

*e-mail: techweb@bourns.com • FAX: (909) 781-5273 (North America); +41- 41 7685510 (Europe)
or the Bourns Web Site: www.bourns.com*



**Leading
by design™**