

NEIL HECKT

COMMUNICATIONS ENGINEERS, experimenters and technicians working with RF filters, oscillators and amplifiers need an instrument to accurately measure small values of inductors and capacitors. The instrument presented here will fill the bill perfectly.

The L/C (inductance/capacitance) meter features a measurement range of 0.001 to 100 microhenrys (μH) and 0.010 picofarads (pF) to 1 microfarad (μF).

The meter automatically selects the proper range, and provides a worst-case accuracy of 3% of reading, and a resolution of four digits. The measurements are displayed on a 16-character intelligent LCD. The meter's sampling rate is about four samples per second.

Circuit description

The heart of the L/C meter is the oscillator circuit on the left side of the schematic in Fig. 1. The oscillator's function can best be visualized by assuming that the output of the LM311 voltage comparator is a square wave at the resonant frequency of the tank circuit formed by L1 and C1. The square wave is applied to the tank circuit through R3 and AC-coupling capacitor C3. The tank circuit filters out the fundamental sine wave, which is then applied to the input of the voltage comparator and causes a square wave to be generated at its output, thus sustaining oscillation.

When power is first applied, the voltage at pin 2 of the LM311 quickly builds up to one half of the supply voltage through the voltage divider formed by R1 and R2. This causes the output, pin 7, to be at a high level equal to the supply voltage. This high level output charges C4 via R4 until the voltage at pin 3 is equal to the voltage at pin 2. The output then switches to a low level, introducing a transient in the tank circuit that causes it to ring at its resonant frequency. This ringing is turned into a square wave at the resonant frequency of the tank at the output

Build this self-calibrating L/C METER

This microcontroller-based digital inductance and capacitance meter is self-calibrating.



pin, thus sustaining oscillation as described above. The square wave will have a 50% duty cycle causing C5 to remain charged to a voltage equal to that of pin 2.

The nominal values of L1 (68 μH) and C1 (680 pF) were chosen because an increase in L of 1 nH (.001 μH) produces a fre-

quency change of slightly less than 5 Hz. The 0.2-second measuring period can resolve 5 Hz and therefore 0.001 μH .

Besides being simple, this oscillator circuit is very reliable. It always starts, and it can tolerate a large variation in the inductances and capacitances used in the tank circuit. The range of

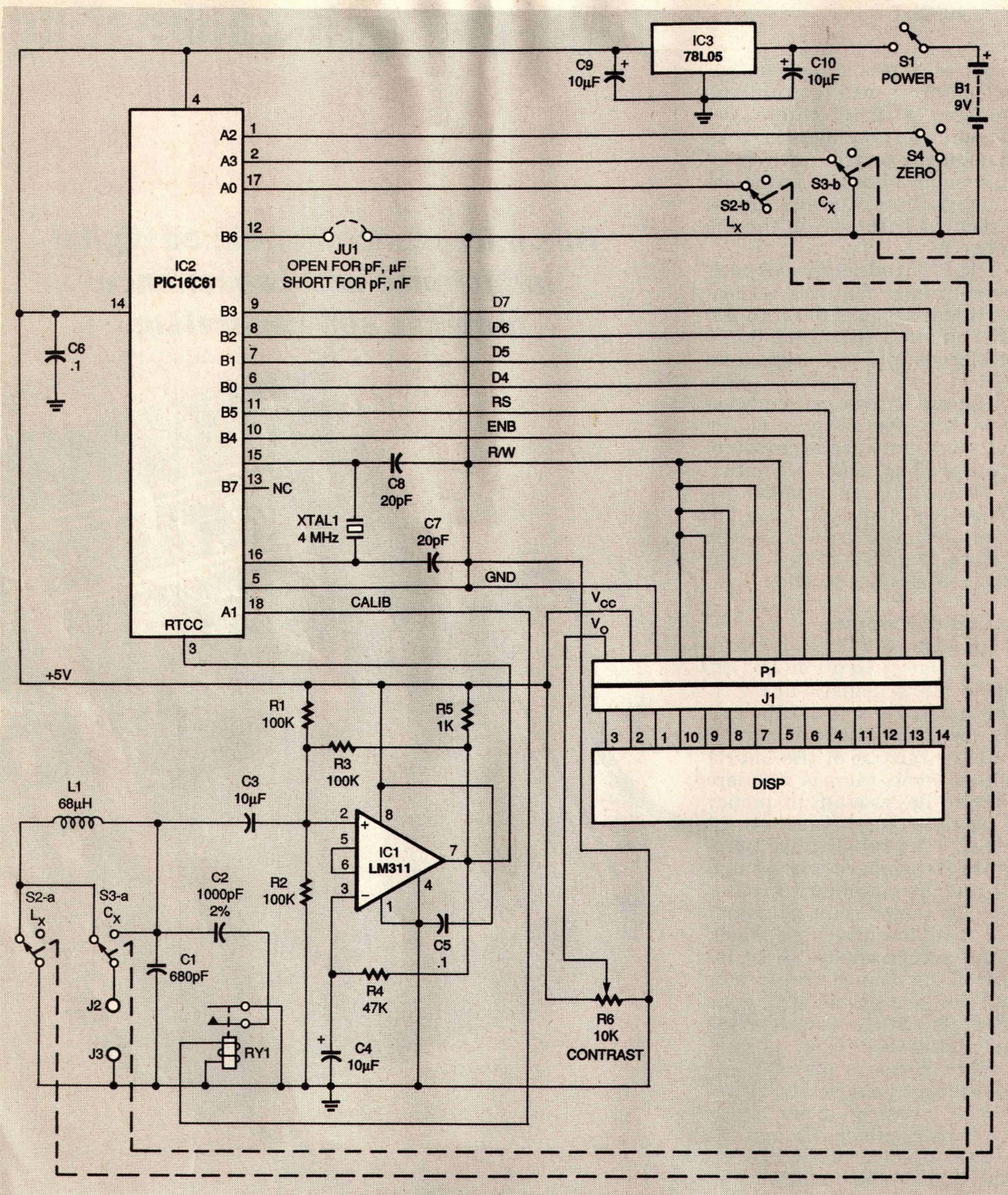

FIG. 1—THE L/C METER SCHEMATIC. The oscillator built around IC1 is the heart of the circuit. IC2, a PIC16C61 microcontroller, is its brains.

inductance and capacitance is limited by the amplitude of the sine wave voltage across the tank circuit. The minimum peak-to-peak voltage is equal to the offset voltage specification of the LM311—about 2 to 10 millivolts. The maximum peak-to-

peak voltage is limited to about half the supply voltage, 2.5 volts. These voltage limits can be translated to inductance and capacitance limits in the simplified equivalent circuit of a parallel resonant tank shown in Fig. 2.

The resistor R is normally part of the inductor and is caused by the resistance of the wire from which it is wound. The maximum impedance of the parallel resonant tank is:

$$Z_{\max} = Q\sqrt{L/C}$$

where $Q = 2\pi fL/R$.

Continued on page 61

L/C METER

continued from page 32

It can be seen that the impedance increases with increasing L or Q and decreases with increasing C. Higher impedances develop higher voltages across the tank in the oscillator circuit described above, while lower impedances develop lower voltages. The maximum value of L is determined by the upper limit of 2.5 volts peak-to-peak while the maximum value of C is determined by the lower limit of 2 to 10 millivolts. For the oscillator described above, these limits are approximately 200 millihenrys and 2.0 microfarads, but they are also a function of the Q of the inductors or capacitors. The L/C meter's top range is specified at 100 millihenrys and 1 microfarad, but values up to the maximum limits mentioned above can usually be measured depending upon their Q. Capacitors must be non-polarized.

The microcontroller

If the oscillator is the heart of the L/C meter, then IC2, a PIC16C61 microcontroller, is its brain. The PIC16C61 is an advanced version of the familiar PIC16C54 18-pin microcontroller from Microchip Technology. The 16C61 has a 14 bit instruction that allows CALLS and GOTOs to anywhere in its 1024-instruction program memory without the page management overhead of the 16C54. It has 36 bytes of RAM and an eight level deep stack rather than the two level stack of the 16C54. The outputs can sink or source up to 20 milliamperes, allowing it to drive LEDs or, in

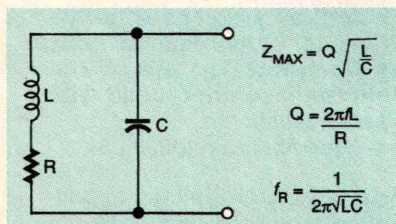

FIG. 2—THE OSCILLATOR'S OPERATION can be best understood by examining this simplified equivalent circuit of a parallel-resonant tank.

TABLE 1—DISPLAY OPTIONS

Inductance	Capacitance (jumper shorted)	Capacitance (jumper open)
0.000 - 0.999 μ H	0.00 - 0.99 pF	0.00 - 0.99 pF
1.000 - 9.999 μ H	1.00 - 9.99 pF	1.00 - 9.99 pF
10.00 - 99.99 μ H	10.00 - 99.99 pF	10.00 - 99.99 pF
100.0 - 999.9 μ H	100.0 - 999.9 pF	100.0 - 999.9 pF
1.000 - 1.999 mH	1.000 - 9.999 nF	1000 - 9999 pF
10.00 - 99.99 mH	10.00 - 99.99 nF	.0100 - .0999 μ F
100.0 - 999.9 mH *	100.0 - 999.9 nF	.1000 - .9999 μ F
1.000 - 9.999 H **	1.000 - 9.999 μ F *	1.000 - 9.999 μ F *

* Programmed into the computer but some values may be out of range.

** Programmed into the computer but out of range.

the case here, a reed relay. It also has interrupts which are not used in L/C meter. Another useful feature is built-in pull-up resistor on the inputs which helps reduce the parts count.

The output of the oscillator is applied to the RTCC REAL-TIME CLOCK COUNTER pin. This increments an 8-bit counter inside the microcontroller. The microcontroller accumulates the count for a period of 0.2 seconds. Discrete signals from the L_x , C_x , and ZERO switches are input to the microcontroller so it knows what the operator wishes it to do. Seven outputs are used to drive the intelligent LCD display

which is operated in its 4-bit (nibble) mode. Four of the outputs are data bits (D4-D7), one is REGISTER SELECT (RS), one is READ/WRITE (R/W) and the last is ENABLE (ENB). One input pin is a jumper which provides two ways to display capacitance values as shown in Table 1.

The jumper-shorted option is for those more inclined toward metric units who want capacitances specified in nanofarads, when appropriate. The jumper-open is for old timers like me, who prefer only picofarads and microfarads. That option has one less digit of resolution in the .0100 to 0.999 range.

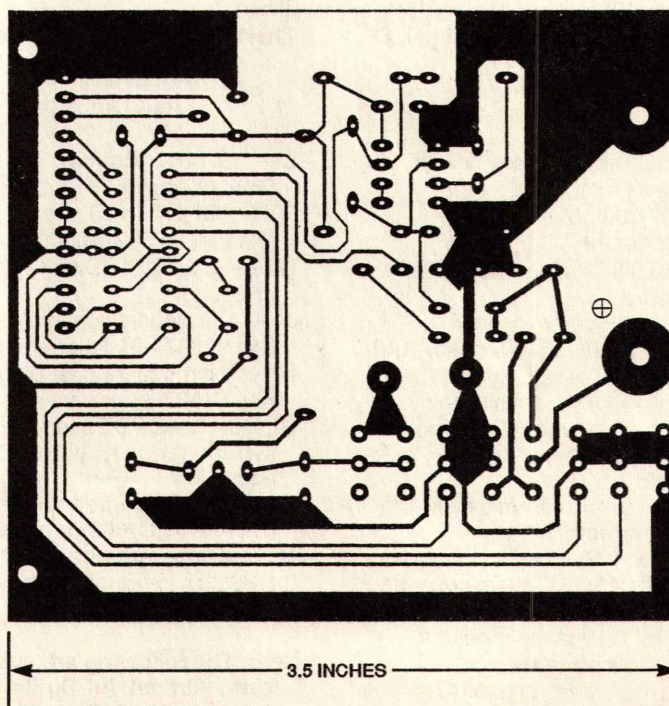

FULL-SIZE L/C METER foil pattern.

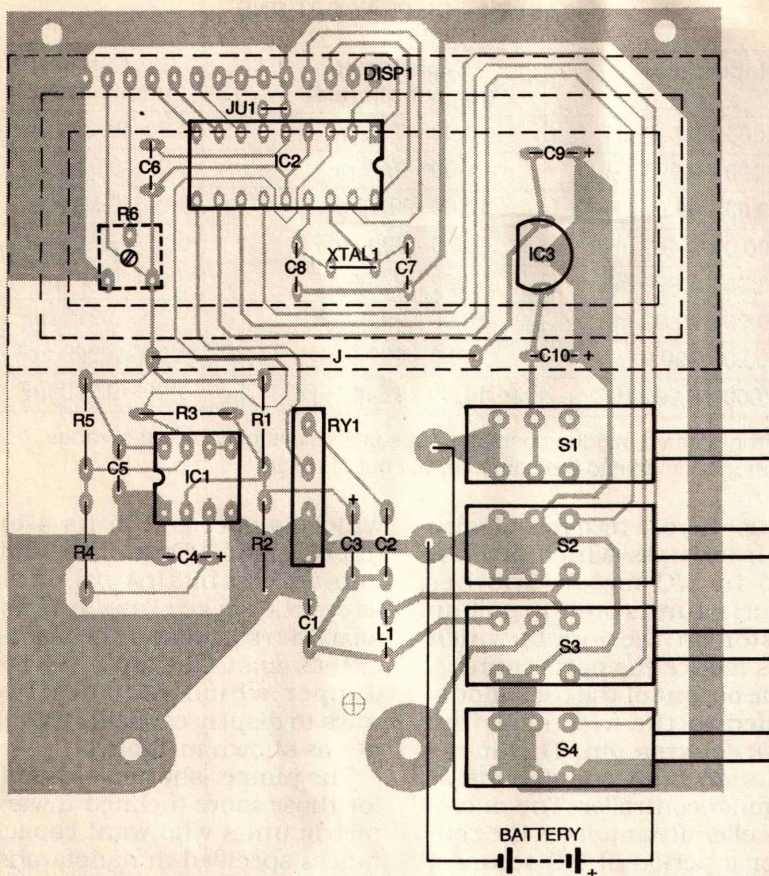

FIG. 3—PARTS PLACEMENT DIAGRAM. Be sure to mount R6 on the rear of the board so you can adjust the display's contrast after the display is installed.

Self-calibrating

One of the truly unique attributes of the L/C meter is that it is self-calibrating. It's really a "put it together and it works"

project. That is, if all the parts are in the right place and you do a good job of soldering, then it will work.

During the calibrate cycle the

microcontroller first measures f_1 , the frequency when only L1 and C1 are in the tank circuit. The frequency will be:

$$f_1 = \frac{1}{2\pi\sqrt{L1C1}}$$

This is one equation with two unknowns and therefore cannot be solved for L1 and C1. To obtain another equation, a known capacitor is switched into the tank circuit. The microcontroller raises the CALIB line to a logic high level. This energizes relay RY1, which switches capacitor C2 (a 1000-pF, 1% polystyrene capacitor) into the tank circuit. That causes the frequency to become:

$$f_2 = \frac{1}{2\pi\sqrt{L1(C1+C2)}}$$

The two equations can be solved simultaneously to give:

$$C1 = \frac{f_2^2}{f_1^2 + f_2^2} C2$$

and finally:

$$L1 = \frac{1}{4\pi^2 f_1^2 C1}$$

Because of this self-calibration capability, the exact values of L1 and C1 are not critical and components with tolerance ratings of 10% are used. The accuracy of the device is dependent upon C2 which is a capacitor with a tolerance rating of 1%..

PARTS LIST

All fixed resistors are 1/4 watt, 5%

- R1, R2, R3—100,000 ohms
- R4—47,000 ohms
- R5—1000 ohms
- R6—10,000 ohms, potentiometer

Capacitors

- C1—680 pF ceramic disc
- C2—1000 pF, 2% (Mouser 140-PF2A102F or equiv.)
- C5, C6—0.1 μ F, ceramic disc
- C3—10 μ F, 10 volts, Tantalum
- C4, C9, C10—10 μ F, 10 volts, electrolytic
- C7, C8—20 pF, ceramic disc

Semiconductors

- IC1—LM311N voltage comparator
- IC2—PIC16C61 microcontroller (Microchip Technology)
- IC3—78L05 voltage regulator

Other Components

- XTAL1—4.0 MHz crystal (Digi-Key X006 or equiv.)

- L1—68 mH (Mouser 434-1120-680L or equiv.)

- RY1—SPST N.O. reed relay (Hamlin HE3621A0500 or equiv.)

- DISP—LM-16151 (Digi-Key OP116 or equiv.)

- J1—14 pin square post socket (Digi-Key 929974-01-36 or equiv.)

- P1—14 pin square post plug (Digi-Key S1022-36 or equiv.)

- S1, S2, S3—DPDT alternate action switch (Digi-Key EG1001 or equiv.)

- S4—DPDT momentary switch (Digi-Key EG1002 or equiv.)

- Miscellaneous: case (PacTec HP9VB), 5-way binding posts, hardware.

Note: The following are available from: Almost All Digital Electronics, 1412 Elm St. S.E.,

Auburn, WA 98092 (206-351-9316):

- Disk containing source and object code: \$19.95 (includes free copy of MPASM, PIC assembler, and MPSIM, PIC simulator)
- Programmed IC2: \$29.95
- Hard-to-find parts kit: \$49.95 (includes printed-circuit board, all switches with buttons, L1, C1, C2, RLY1 and U2)
- Complete kit: \$79.95 (includes machined case with panel decal)
- Assembled unit: \$99.95

Include \$4.00 shipping and handling per order. Add and additional \$4.50 on C.O.D. orders. Washington State residents add 8% sales tax

LISTING 1

```

INITIALIZE THE CPU AND I/O PORTS
INITIALIZE THE LCD DISPLAY
WHILE Lx OR Cx are ON
    DISPLAY "SWITCH ERROR"
WEND
(The computer cannot calibrate itself if Lx or Cx are on. The unit
waits for the operator to clear the switches.)
DISPLAY "WAIT" (wait 10 seconds for the oscillator to stabilize.)
CALIBRATE:
    DISPLAY "CALIBRATING"
    MEASURE F1
    SWITCH IN THE CALIBRATION CAPACITOR
    MEASURE F2
    SWITCH OUT THE CALIBRATION CAPACITOR
    COMPUTE C1=F2^2 / (F1^2 - F2^2) C2
    COMPUTE L1=1 / (4 p^2 F1^2 C1)
DO (loop continuously)
    IF Lx and Cx are OFF
        IF ZERO
            GOTO CALIBRATE (re-calibrate the unit)
        ELSE
            DISPLAY "READY" (ready to measure Lx,Cx,or be ZEROed)
            MEASURE and STORE F1
        END IF
    ELSEIF Lx ON AND Cx OFF
        MEASURE F2
        IF ZERO ON
            MEASURE and STORE F1
            DISPLAY "0.000"
        ELSE (ZERO OFF)
            COMPUTE Lx=(F1^2 / F2^2 -1) L1
            DISPLAY "Lx="
            DISPLAY VALUE in engineering units
        END IF
    ELSEIF Cx ON AND Lx OFF
        MEASURE F2
        IF ZERO ON
            MEASURE and STORE F1
            DISPLAY "0.000"
        ELSE (ZERO OFF)
            COMPUTE Cx=(F1^2 / F2^2 -1) C1
            DISPLAY "Cx="
            DISPLAY VALUE in engineering units
        END IF
    ELSE (Lx and Cx both ON)
        DISPLAY "SWITCH ERROR"
    END IF
LOOP

```

The unit can be re-calibrated by pressing ZERO when L_x and C_x are both off. This may be desirable when measuring very small values. In such cases, the unit should be allowed to warm up for about 5 minutes to allow the oscillator to thermally stabilize.

Making measurements

When the L_x and C_x switches are off, the microcontroller con-

tinuously measures f_1 to track any drift in frequency. When the L_x switch is depressed, the unknown inductor is placed in series with L_1 . The total inductance is then $L_1 + L_x$. This causes the frequency to change to:

$$f_2 = \frac{1}{2\pi\sqrt{(L_1 + L_x) C_1}}$$

This equation can be solved, si-

multaneously with the equation for f_1 to produce:

$$L_x = \left[\frac{f_1^2}{f_2^2} - 1 \right] L_1$$

Similarly when the C_x switch is depressed the unknown capacitor is placed in parallel with C_1 . The total capacitance is then $C_1 + C_x$.

$$f_2 = \frac{1}{2\pi\sqrt{L_1 (C_1 + C_x)}}$$

A DESIGN THAT IMPROVES WITH AGE

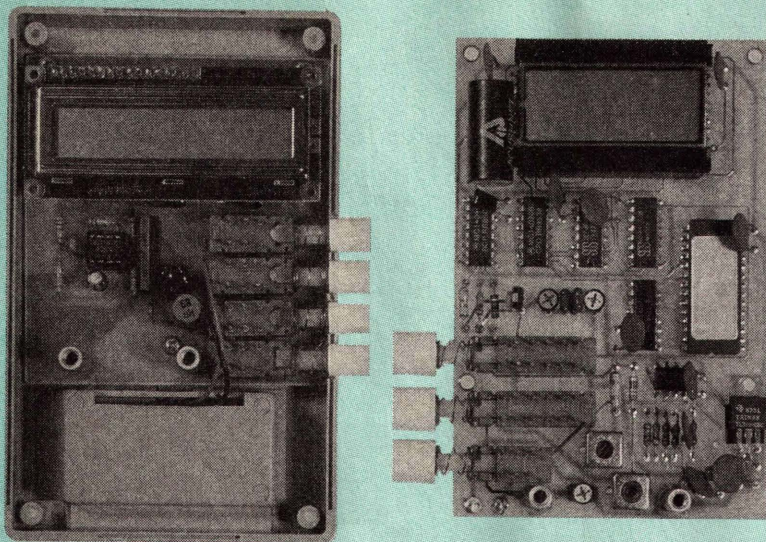

THE NEW L/C METER is shown on the left, mounted in its case. The original version's PC board is shown on the right. Note how the PC board size and complexity have been reduced greatly.

In July of 1988, *Radio-Electronics* magazine (*Electronics Now's* predecessor) presented the L/C Meter I. It measured inductance and capacitance by detecting the shift in frequency of an oscillator when an unknown is inserted into its tank circuit. At that time it was postulated that a microcontroller would be the best solution to the computation and display of the result. However, there were no inexpensive microcontrollers available back in 1988. Instead a ROM look-up table approach was used.

That was 1988, this is 1996 and the Microchip Technology's series of PIC mi-

crocontrollers allows the use of a microcontroller in this version of the L/C Meter. The result is increased resolution and range as well as intelligent display of the result in engineering units. The technique and the oscillator circuit are essentially the same as original L/C Meter, which had 12 ICs and an LCD display. This updated version uses only 3 ICs and features an intelligent LCD display. The original L/C Meter had to be manually calibrated, while the new unit is self-calibrating. Best of all, the new L/C Meter is significantly less expensive than the original. Ω

Which is solved for C_x , with the equation for f_1 , to produce:

$$C_x = \left[\frac{f_1^2}{f_2^2} - 1 \right] C_1$$

Stray inductance and capacitance

The circuit traces on the printed-circuit board, the switches, and the test leads all contribute a small amount of stray inductance (L_s) and capacitance (C_s). These stray values add to the values of L_1 or C_1 when the L_x or C_x switches are pressed, slightly affecting the frequency of f_1 . The unit is zeroed by pressing the ZERO switch, which causes the unit to re-measure f_1 with the stray values in the circuit.

To zero L_s the operator must short circuit the test leads,

press L_x and then press the ZERO button. Similarly, for capacitors, the operator open circuits the test leads, presses C_x and then presses ZERO.

This zero operation is good until the L_x or C_x switch is turned off. If the L_x or C_x switch is again turned on the unit must be re-zeroed.

Floating-point math

From all of the above equations it would seem that there is some relatively high-powered math involved and there is. The lower half of program memory in the microcontroller contains a complete 32-bit floating-point math package. The math package includes ADD, SUBTRACT, MULTIPLY and DIVIDE instructions. It also contains conversions from integer to floating-point, float-

ing-point to integer and integer to binary-coded decimal (BCD).

The computer measures frequency by counting the number of oscillator cycles for a period of 0.2 seconds. The result is an integer. This number is converted to floating-point and all calculations are done in floating-point. When the values of L_x or C_x are finally computed, the answer is converted to an integer and then to BCD for display.

The upper half of the microcontroller's program memory contains the functional software which is described in Listing 1 by a pseudo BASIC-like, high-level language.

Construction

The L/C meter is indeed simple and there is no particular order of assembly. Refer to Fig. 3, the parts-placement diagram. Note that there is only a $\frac{3}{8}$ -inch space under the display when it's mounted. Leave enough lead length on the taller parts so you can tip them at an angle to reduce their height. Figure 4 is a photograph of the board under the display. Note how the crystal and voltage regulator are installed at an angle.

Start assembly with the resistors. Then solder in the sockets for the IC's, the capacitors, and then the switches. The switch terminals should just barely stick through the printed-circuit board in order for the shafts to line up with the holes in the case. Be careful not to install the switches upside-down. Remove the little tin rivet from under the brass leaf of the ZERO switch only. This converts it from an alternate-action switch to a momentary-contact switch (see Fig. 5).

Solder P1, the male, square-post header, at the top of the PC board. Install the contrast control, R6, on the back of the printed-circuit board otherwise you will not be able to adjust it with the display installed. Install the two $\frac{3}{4}$ -inch spacers for the test jacks as shown in Fig. 5. This should complete printed-circuit board assembly. Solder J1 to the display unit. A single-sided printed-circuit board is used so don't forget the one

jumper wire needed as indicated on the parts layout. Decide which type of capacitor display you prefer. If you prefer to indicate nanofarads, solder jumper wire JU1 as indicated on the parts layout.

Pass the leads from the battery clip through one of the slots in the battery box of the case and solder them to the appropriate pads of the printed-circuit board. Plug in the display and turn on the unit. If you don't see anything on the display, don't panic, try adjusting R6, the contrast control. The unit will display WAIT for 10 seconds followed by CALIBRATING for two seconds followed by READY. If it does, you're up and running. Adjust the contrast control so the background is just barely visible. Install the printed-circuit board in the bottom of the case using three No. 4 sheet metal screws. Install the top cover of the case and install the binding posts as shown in Fig 5. Test leads should not exceed 4 inches in length with a banana plug at one end and alligator clip at the other.

If your finished unit doesn't work, remove the printed-circuit board and carefully inspect to see you have soldered everything that should be soldered, and that you have not created any inadvertent solder bridges. It is very unlikely you will have any problems; however, if you purchased your kit from the source in the parts list they will try to fix it free except for a

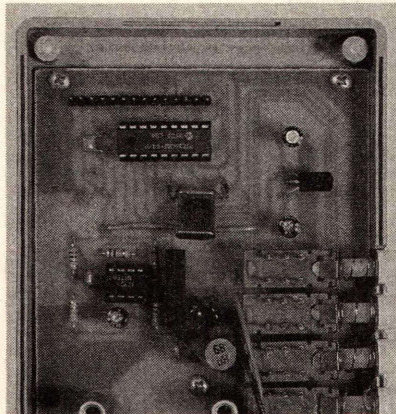

FIG. 4—THE AREA UNDER THE DISPLAY has a maximum clearance of $\frac{3}{8}$ inch. Note how the crystal and voltage regulator are tilted to decrease their heights.

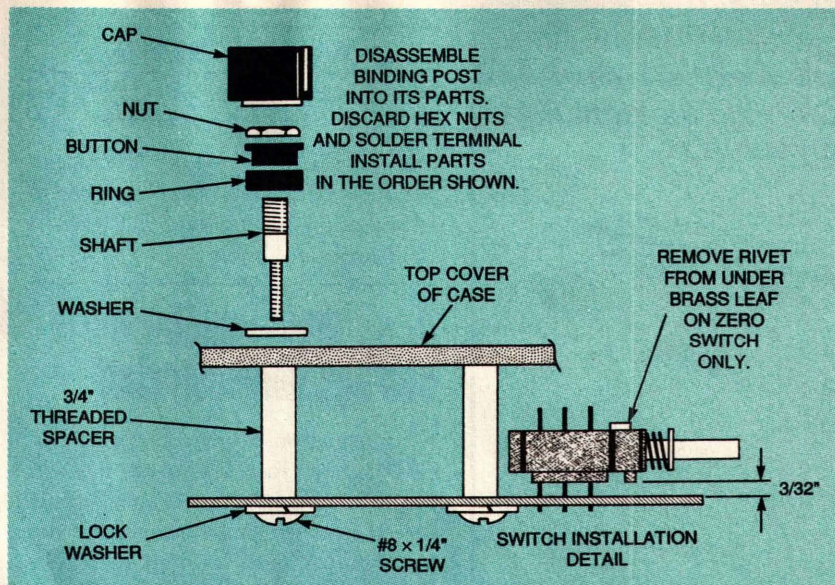

FIG. 5—MECHANICAL DETAILS. Remove the rivet from the Zero switch to convert it to a momentary-contact switch.

\$4.00 return postage and handling fee.

For those who wish to make their own printed-circuit board a full size PC-board foil pattern is provided. The switches called out in the parts list should fit without problem. When the original L/C Meter was designed, a large volume of surplus switches was obtained. These are supplied with the new L/C meter kits from the source listed at the end of the Parts List. For those with the capability to program their own PIC16C61 the code can be downloaded from the Electronics Now BBS (516-293-2283 N81). Look for LCM.ZIP. The code can also be purchased from the source listed in the parts list and includes a free copy of MPASM, the PIC assembler, and MPSIM, the PIC simulator.

Operation

The typical stray inductance is .04 to .06 μH and the typical stray capacitance is 5 to 7 pF. When measuring inductors less than 5 μH or capacitances less than 50 pF, it is advisable to zero the unit first. For larger values, the strays are insignificant to the result. It is difficult to retain a reading of 0.000 pF because of the extreme sensitivity of the meter. Your body capacitance influences the reading. Try zeroing the capacitance and then

move your hands around the test leads without touching them. You will find you can adjust the reading a few hundredths of a picofarad.

To measure inductance, place the unknown across the test leads and depress L_x . The inductor must have DC continuity, or the unit will display NOT AN L. To measure capacitance place the unknown across the test leads and press C_x . If the unknown is out of range the unit may break into spurious oscillation and display random or rapidly changing values.

The oscillator tends to drift a few hertz during the first few minutes of operation. When measuring very small values the unit should be allowed to warm up for about five minutes and then re-calibrated and zeroed.

Accuracy and resolution

The L/C meter accuracy is specified at 3% of reading. This is vastly superior to units specified as percent of full scale. For example a unit on a 1-mH range, specified at 1% of full scale, would have a maximum error of 10 μH which could be as much as a 100% error when measuring a 10 μH inductor. Our L/C meter would have a maximum error of 3% for the 10 μH inductor.

The author measured about
Continued on page 88

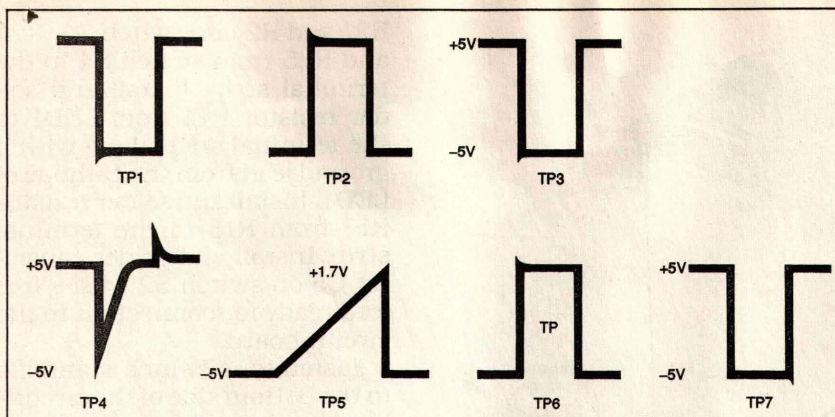

FIG. 5—OSCILLOSCOPE WAVEFORMS at selected test points, as shown on Fig. 1

cuit board so that there is a reading of 0.0 millivolts between pins 2 and 3 of IC4.

If you should encounter any problems with the circuit at this time, you might want to observe the waveforms at the test points identified in the schematic, Fig. 1. Figure 5 illustrates the waveforms to be expected at those test points.

Introduce a 60-Hz signal from a separate, low-voltage filament-style transformer to CHANNEL 1 of your oscilloscope, and display two or three cycles at about six divisions of vertical height. With the adapter set at 10 milliseconds, you should see a waveform with about 50% or more of each cycle in bold relief (intensified) with the remainder dimmed.

Adjust your oscilloscope's intensity control for the best contrast of the two parts of the trace. The positive half of each cycle should be bold. If it is not, set rear panel switch S3 (OUTPUT SLOPE) to (-), to allow the bold section to lengthen as the multiplier (R18) is advanced clockwise. Rotate the knob of panel potentiometer R6 (TRIGGER LEVEL) back and forth and observe how the cursor can be triggered at any point on the positive-going slope. (Reverse S1's position to trigger on the negative-going slope.)

Advance the turns counterclockwise, and observe the bold section lengthening towards the next cycle so that it eventually forms a complete bold trace. At this setting, the adapter output pulse is equal to the time period of the 60-Hz sig-

nal (16.7 milliseconds). A very small advance of the turns counter will cause each alternate cycle to dim. Adjust your oscilloscope's sweep speed to see this clearly, and then set the turns counter to $\times 1.67$. Now adjust calibration trimmer R15 to locate the trace exactly at the point where it changes from full bold on each cycle, to bold on each alternate cycle.

This completes the calibration and operating instructions for the time period mode. As expected, any type of waveform can be measured by simply manipulating the slope, range, and multiplier controls of the unit.

To use the delayed sweep mode, connect output jack J2 to the TRIGGER INPUT jack on your oscilloscope (instead of the Z axis jack). Introduce the signal to CHANNEL 1, set switches S1 and S3 to match the oscilloscope waveform's slope, and adjust the range controls to the approximate signal time period. Switch the oscilloscope to EXT. TRIGGER), and rotate the turns counter to keep that part of the signal-to-be-viewed on screen as you increase sweep speed to expand the signal.

Regulated power supply

A schematic for a wall outlet mounted ± 5 -volt power supply for this oscilloscope accessory is included because commercial versions are not widely available. The author built the supply into a two-part aluminum project case measuring $3\frac{1}{4} \times 1\frac{1}{2} \times 2$ inches. These cases are standard, off-the-shelf items. Ω

60 components on a HP4275A L/C meter. Measuring these components on the L/C meter prototype found an average error of just 0.60% for inductors and 0.13% for capacitors. These values ranged from .1 μH to 6.8 μH for the inductors and 2.7 pF to .068 μF for the capacitors.

The prototype was also used to measure the values of a series of 5% tolerance inductors up to 150 mH, and a series of 10% mylar capacitors up to 1.6 μF . All of these parts measured well within the specified tolerance of their marked values indicating the accuracy of the L/C meter extends at least up to 150 mH and 1.5 μF . These measurements were made on a single unit. The measured values could vary, from unit to unit, by 1% to 2% as a function of the exact value of C2, 1% tolerance polystyrene capacitor.

The L/C meter has a four-digit resolution, which for small values of L and C are 1 nH and .01 pF. You cannot accurately measure values this small. The resolution greatly exceeds the accuracy.

You can measure values as small as .01 μH and .1 pF with about 15% accuracy. However, you generally won't find components this small. For example a piece of wire less than one inch long has an inductance of 0.01 μH .

The resolution of the meter is, however, relative, and can be used for sorting a batch of similar components as it truly does indicate which are slightly larger of smaller than others. Also, for small values of inductance, the leads will contribute quite a bit to the value. Measuring from the ends of the leads instead of next to the body of the component can add up to 0.025 μH .

For small values the frequency of operation (test frequency) is about 750 kHz decreasing to about 60 kHz at .1 μF or 10 mH and about 20 kHz at 1 μF or 100 mH. Ω