

## EYE PROTECTION

CONTENTS	PAGE
1. GENERAL . . . . .	1
2. TYPES OF EYE PROTECTION AND ORDERING INFORMATION . . . . .	1
3. SAFETY GLASSES . . . . .	2
4. PLASTIC GOGGLES . . . . .	3
5. USE OF EYE PROTECTION . . . . .	3
6. CARE OF SAFETY GLASSES AND PLASTIC GOGGLES . . . . .	4
7. MICROWAVE EXPOSURE PRECAUTIONS	4

- 1.05 Each employee shall be responsible for the care and condition of safety glasses and goggles in his possession. They should be stored in a suitable container when not in use.
- 1.06 Interchanging of goggles among employees should not be made unless the goggles have first been washed with soap and warm water. Any face soap is satisfactory for this purpose.
- 1.07 The goggles described herein, having flexible frames, may be worn over regular safety glasses, personal or safety prescription glasses, or in lieu of regular safety glasses.
- 1.08 Contact lenses do not provide protection to the wearers' eyes. Personnel who wear contact lenses must wear either regular or special eye protection when such protection is required (5.01).

### 1. GENERAL

1.01 This section covers the description, care, identification, and use of industrial safety glasses and goggles as eye protection in the performance of any work where there is a possibility of an injury to the eyes due to flying objects, particles, or splashes.

1.02 This practice is reissued to describe the type of special eye protection to be worn, dependent upon the occupational hazards encountered; also, to include requirements described in the USA Standard Practice for Occupational and Educational Eye and Face Protection, Z87.1. Since this reissue is a general revision, arrows used to indicate changes have been omitted.

1.03 This practice is identical to Section 081-020-011 and replaces Section 075-142-301 which is canceled.

1.04 Eye protection shall be worn by all personnel whenever they are: (1) performing, (2) observing, and (3) supervising a work operation where there is a reasonable probability of injury to the eyes that could be prevented by such protection.

\*\*Reprinted to comply with modified final judgment.

### 2. TYPES OF EYE PROTECTION AND ORDERING INFORMATION

2.01 *Regular Protection:* "Regular" protection consists of frontal eye protection against flying or moving objects. The lenses and frames are designed, manufactured, and assembled to comply with minimal standards for industrial safety glasses.

2.02 Plano and prescription safety glass lenses must meet the thickness requirements (3.0 mm to 3.8 mm) and are heat treated to withstand the required impact resistance test standards in Z87.1.

2.03 Plastic safety frames are made of slow-burning materials, tested to meet specific strength requirements, and are designed to retain the lenses under impact.

2.04 Every manufacturer is required to include his own distinct mark of identification on frames and lenses to certify that the product meets the required safety standards. (See Fig. 1.)

**2.05** Supervisors must be able to tell the difference between industrial quality safety glasses and those normally worn for dress wear.

**2.06 *Special Protection:*** "Special" protection consists of side as well as frontal eye protection from flying or moving objects and irritating liquids. The type to be used is dependent upon the potential hazard in the work being performed.

**2.07** The goggles described in this paragraph are required to meet impact resistance standards specified in Z87.1 and, therefore, can be worn with or without other spectacles. The two models available for use whenever special protection is required are as follows.

- (1) ***Impact-Type (Fig. 2)***—Provides protection from impact caused by flying particles.
- (2) ***Dust, Splash, and Impact-Type (Fig. 3 and 4)***—Provides protection from flying dust, liquids, and splashes as well as impact protection. The ventilation is designed to render the goggles as splash-proof.

**2.08** The figures included in this part show the part numbers of the various replaceable parts together with their corresponding names. Only those parts that are replaceable have part numbers shown.

**2.09** When ordering parts for replacement purposes, give both the part number and the name of the part.

### 3. SAFETY GLASSES

**3.01** The B safety glasses, or those approved substitutes, are to be worn on all work operations where regular eye protection is required as defined in 2.01.

**3.02** The plastic frames of B safety glasses are available in either smoke or mahogany colors with eye sizes of 44, 46, or 48 mm and are provided with a universal fit bridge design. The temples are available, in 1/4-inch increments of length, in overall lengths from 5 1/4 through 6 1/4 inches for spatula type and from 6 to 7 inches for cable type.

**3.03** The sizes and types of frames listed in 3.02 are expected to provide sufficient latitude to accommodate 80 to 90 percent of all wearers of plano safety glasses. Special arrangements should be made locally for employees requiring combinations of bridge and/or eye size not covered in this section.

**3.04** Prescription safety glasses should be obtained in accordance with the locally established routine of the operating company.

**3.05** Suitable cases for protecting the lenses, when the safety glasses are not in use, are to be obtained in accordance with local instructions.

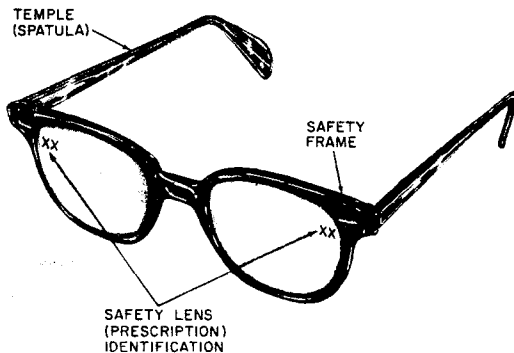
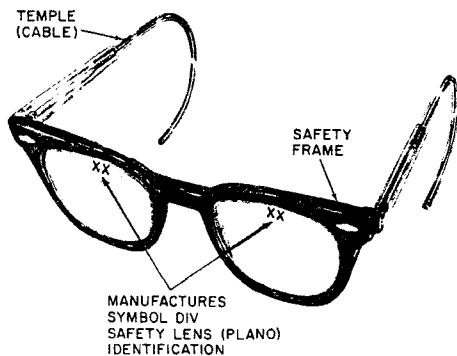
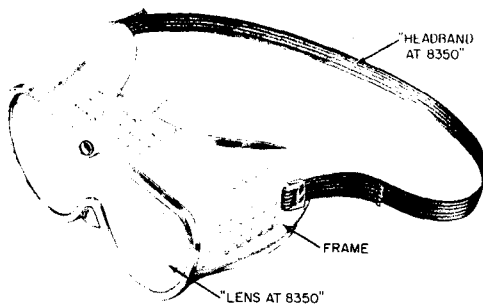
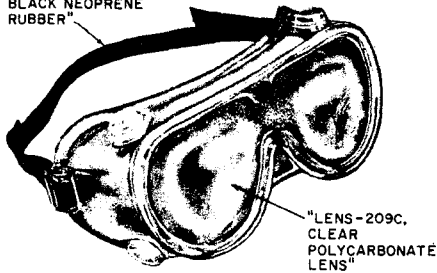

Fig. 1—B Safety Glasses

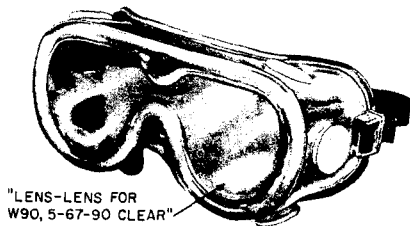

**Fig. 2—B Plastic Goggles**

"HEADBAND-213, BLACK ELASTIC"  
OR "HEADBAND-251,  
BLACK NEOPRENE  
RUBBER"



**Fig. 3—American Optical 484B Chemical Goggles**



**Fig. 4—Bausch & Lomb W90 BAL-GUARD Fog Ban Goggles**

#### 4. PLASTIC GOGGLES

##### Impact Protection

**4.01** The B plastic goggles (Fig. 2) consist of a replaceable clear polycarbonate impact-type resistant lens, a soft vinyl plastic ventilated frame, and a headband. They shall be worn for "special" impact protection as defined in 2.06. They may also be worn for "regular" protection as defined in 2.01.

##### Dust, Splash, and Impact Protection

**4.02** The American Optical 484B chemical goggles (Fig. 3) are clear lightweight flexible mask goggles. They should be worn for "special" splash or spray protection as outlined in 5.02(b). They may also be worn for either "special" or "regular" protection as outlined in 5.02(a) or 2.01.

**4.03** The Bausch & Lomb W90 BAL-GUARD\* fog ban goggles (Fig. 4) have a transparent colorless frame with baffled screened vents and a double-glazed colorless lens. It protects the wearer exposed to dust and splash-type hazards. They can also be worn for impact protection.

\*Registered trademark of Bausch & Lomb, Inc.

**4.04** Impact protection models and splash-proof type goggles are available from other suppliers. However, when such purchases are made, it is imperative that the goggles conform to the standards specified in Z87.1.

**4.05** The No. 33 plastic goggles case (Fig. 5) is suitable for storing the goggles described in this section.

#### 5. USE OF EYE PROTECTION

**5.01** In order to minimize the opportunities for overlooking the use of protection when it is required, "regular" or "special" eye protection will be worn by all tool-using employees at all times. The exception is when an employee is performing work operations of a clerical nature or attending meetings where material or tool demonstrations are not the subject matter.

**5.02** "Special" eye protection is required when performing or observing at close range the following work operations.

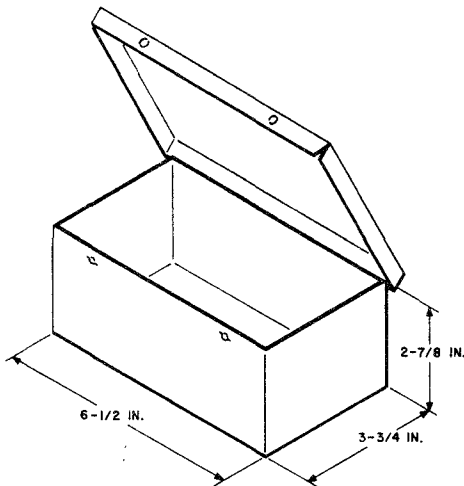

Fig. 5—No. 33 Plastic Goggles Case

**Note:** This list is not all inclusive.

(a) **Special Protection—Impact-Type Goggles**

- (1) Drilling or chipping stone, brick or masonry, breaking concrete pavement, etc, by hand tools or with power tools or any other operation which produces chips
- (2) Working on or around high-speed emery or other grinding wheels unprotected by guards
- (3) Cutting or chipping terra cotta ducts, tiles, etc
- (4) Using power-actuated stud drivers
- (5) Wiping lead sleeves, either using a soldering pot in a manhole or an acetylene torch on aerial work.

(b) **Special Protection—Dust—Splash-Proof**

- (1) Working under motor vehicles requiring hammering
- (2) Cleaning operations using compressed air, steam, or sandblast

- (3) Acetylene welding or similar operations where sparks are thrown off
- (4) Handling fiber conduit eye-irritating dust from coal tar pitch is difficult to control
- (5) Handling battery cells or counter cells
- (6) Handling battery and counter cell solutions and dry chemicals
- (7) Taking battery readings; ie, hydrometer and thermometer
- (8) Handling air filters, fluorescent tubes, and cathode ray tubes
- (9) Handling of epoxy resins, activators, curing agents, and solvents, and while cleaning tools that have come in contact with these materials
- (10) When work is performed above eye levels and dirt or debris is likely to be disturbed (tree trimming, removing acoustical ceiling tile, placing or removing wires or cables, etc).

**6. CARE OF SAFETY GLASSES AND PLASTIC GOGGLES**

- 6.01** Safety glasses and goggles shall not be left lying around nor stored among tools where they can be damaged. When not in use, store them in the appropriate case.
- 6.02** They should be kept clean and bright to obtain best results. Smudgy lenses can be cleaned by wiping with a clean cloth or any other suitable material. Dirty lenses can be cleaned by washing with soap and water.
- 6.03** Pitting and scratches on a plastic goggle lens can greatly decrease the effectiveness of the goggles as eye protection. Such damaged lens should be replaced.

**7. MICROWAVE EXPOSURE PRECAUTIONS**

- 7.01** It has been established that with sufficient microwave exposure, cataracts can be produced on the lens of the eye. Therefore, one should never look into an open waveguide which is connected to an energized transmitter. The basic effect of radiation on any living organism is the damage or

destruction of cells. Depending on the frequency and the time length of the radiation exposure, size of the dose, and the body area exposed, the effect will vary greatly.

**7.02** Further information on radiation reference can be found in Sections 010-150-001, -002, and -003.

**7.03** Employees whose work assignment requires exposure to laser beams will wear suitable safety goggles to protect them against its effects.