

B AND C IMPACT WRENCHES

DESCRIPTION, CARE, MAINTENANCE, AND GENERAL USE

	CONTENTS	PAGE	
1.	GENERAL	1	1.02 This section is reissued to rate the B impact wrench (MD) and to add some minor revisions. This and other additions to the text are indicated by change arrows.
2.	DESCRIPTION	1	1.03 The wrench and socket are used in placing or removing nuts and drive screws of pole-line hardware. The bits are used in boring holes through wooden objects such as poles, log anchors, and building beams.
	B IMPACT WRENCH (MD)	1	1.04 Approved double insulated power tools do not require grounding. All other portable power tools equipped with metal housing must be effectively grounded per Section 620-103-010.
	C IMPACT WRENCH	2	1.05 The inspection, maintenance, and general use of B and C power bits are covered in Section 081-745-105.
	B SOCKET	2	
	B AND C POWER BITS	3	
3.	CARE	3	2. DESCRIPTION
	B AND C IMPACT WRENCHES	3	B IMPACT WRENCH (MD)
	B SOCKET	3	2.01 The B (MD) impact wrench (Fig. 1 and 2) operates on 115 volts ac or dc, develops about 150 foot/pounds of torque, and is reversible. The wrench is a 1/2-inch capacity tool, equipped with a 7/16-inch hexagonal quick-change chuck, pistol-grip handle, nonlocking on-off trigger switch, reversing switch, 15-foot 3-wire cord, and 3-prong plug. One wire connects the grounding prong of the plug to the case of the wrench.
4.	MAINTENANCE	4	2.02 The direction of rotation of the chuck is determined by the position of the reversing switch.
	B AND C IMPACT WRENCHES	4	
5.	POWER SOURCES AND GROUNDING	4	
6.	EXTENSION CORDS	4	
7.	SAFETY PRECAUTIONS	5	
1.	GENERAL		
1.01	This section covers the description, care, maintenance, and general use of the C impact wrench. The B socket and B and C power bits used with this wrench are described.		

**Reprinted to comply with modified final judgment.

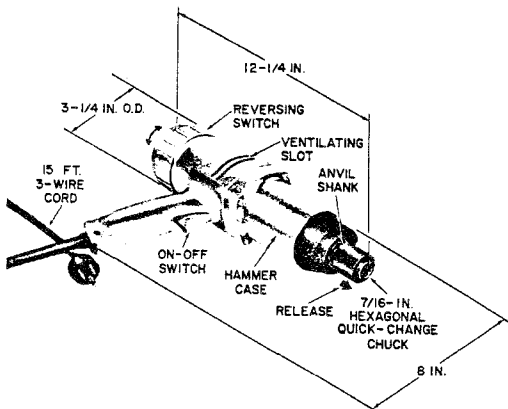

Fig. 1—B Impact Wrench With End Cap Reversing Switch

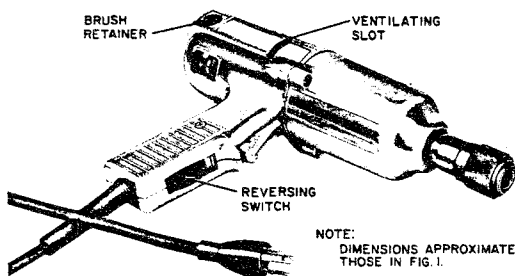

Fig. 2—B Impact Wrench With Reversing Switch in Handle

C IMPACT WRENCH

2.03 The C impact wrench (Fig. 3) is a double insulated electric tool having a housing and handle made of high impact plastic. ♦The gear case may be made of metal. ♦It is a commercial, 115 volt ac-dc, reversible, heavy duty, 1/2-inch capacity electric wrench that develops about 288 foot/pounds of torque. It is equipped with a nonlocking trigger, yellow jacketed 2-conductor cord approximately 6 feet long, and a 7/16-inch hexagonal quick-change chuck.

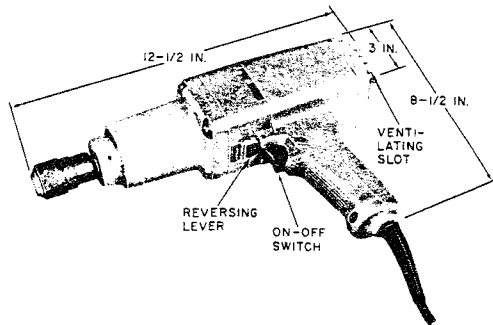

Fig. 3—C Impact Wrench With Reversing Switch Over Trigger

2.04 ♦The C impact wrench has a switch that determines the direction of rotation of the chuck. As with the B wrench, this switch is different from one supplier to another. Some models have the switch located over the trigger, and others are operated by a cap at the rear of the motor.♦

B SOCKET

2.05 The B socket has 8 points (Fig. 4) and a 7/16-inch hexagonal shank to fit the chuck of the B or C impact wrench.

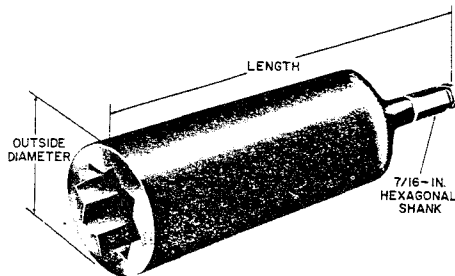

Fig. 4—B Socket

- 2.06 The socket is available in sizes listed in Table A.

TABLE A
B SOCKET - SIZES, DEPTHS, AND DIMENSIONS

SIZE BOLT DIAMETER (INCHES)	DEPTH OF SOCKET INSIDE (INCHES)	OUTSIDE DIAMETER (INCHES)	LENGTH OVERALL (INCHES)
3/8	1	1-1/4	3-1/2
1/2	1-1/8	1-1/2	3-5/8
5/8	4	1-3/4	6-1/2
3/4	4	2	6-1/2
1	4	2-1/2	6-1/2

- 2.07 The intended use of the impact wrench with the 5/8-, 3/4-, and 1-inch sockets is to run these galvanized nut sizes to the torque capability of the tool, then hand tighten. Care should be used in fastening with the 3/8-, 1/2- and 5/8-inch sockets as the torque capability of the wrench can strip threads or shear the bolts.

B AND C POWER BITS

- 2.08 The B power bit (Fig. 5) has a solid center twist, single spur and cutter, lead screw, and 7/16-inch hexagonal shank to fit the chuck of the impact wrenches. The C power bit (Fig. 6) is the same except for the hollow center twist.



Fig. 5—B Power Bit



Fig. 6—C Power Bit

- 2.09 B and C power bits have the same type of head as standard construction bits but are stronger and are described in Section 081-745-105.

- 2.10 B and C power bits may also be used with the C electric drill and the B ratchet brace.

3. CARE

B AND C IMPACT WRENCHES

- 3.01 *Never* carry the impact wrench by the line cord as this may strain or damage the cord connections.

- 3.02 Avoid rough handling of the line cord. Dragging it over rough or sharp surfaces or allowing it to lie in oil or grease will decrease the life of the rubber jacket.

- 3.03 The life of the motor of these tools depends upon proper lubrication and ventilation. Be sure the ventilating slots (Fig. 1, 2, and 3) are clean.

- 3.04 Keep the outside of the housing clean.

- 3.05 Before use, check that bolts and screws in the housing are tight.

- 3.06 After use, wipe the wrench and cord clean. Safely store in a designated location. See that the cord does not have sharp bends or kinks.

- 3.07 *When driving small size nuts, do not impact too long or stripped threads and broken bolts will result.*

- 3.08 *Be sure socket is a snug fit in the wrench chuck and a close fit on the nut or drive screw. Loose fits cause loss of impact power.*

B SOCKET

- 3.09 After use, wipe the socket clean inside and out with an oily cloth and store with the impact wrench.

4. MAINTENANCE

B AND C IMPACT WRENCHES

4.01 Before using, inspect the cord for damage to insulation or connectors.

4.02 *Do not make temporary repairs of any kind. Never* tape over defects in the cord. Return wrenches with damaged cords to the Western Electric Company for repairs.

4.03 A supervisor or designated person should make the following tests monthly on a B impact wrench, using a volt ohmmeter. The tests do not apply to a C impact wrench.

(a) Test the continuity of the wire in the cord from the grounding prong of the plug to the case of the wrench.

(b) Test the two remaining cord wires to assure that neither is shorted to the case of the wrench. Operate the trigger switch when making this test.

4.04 Return any B impact wrench that fails either of the above tests for repairs in accordance with local instructions.

4.05 Inspect the brushes and commutator frequently. Loss of power and serious sparking are indications that the brushes are worn excessively or making poor contact with the commutator.

4.06 Before using the wrench, place a few drops of machine oil around the shank of the anvil (Fig. 1) where it emerges from the bushing at the front of the hammer case. Hold the wrench with the chuck uppermost.

4.07 Once each month, remove the hammer case and grease the impact unit with a good grade of ball or roller bearing grease, lubricating the jaws, cam balls, and bearing surfaces. Do not use too much grease as this will cause the wrench to operate sluggishly. Do not apply grease to the cylindrical surface of the hammer since this is not a bearing surface.

4.08 Annually, return the wrench for periodic cleaning of the hammer mechanism and lubrication of the gear housing and commutator bearing.

4.09 Wrenches shall be returned when repairs are major or field replacements are impractical.

5. POWER SOURCES AND GROUNDING

5.01 The wrench can be used with standard portable engine-generators. These power sources are normally ungrounded.

WARNING: *Care shall be taken when boring with the wrench to avoid coming in contact with any power circuits.*

5.02 The B impact wrench shall be grounded in accordance with Section 620-103-010.

6. EXTENSION CORDS

6.01 Where extension cords are required for the B impact wrench, use only the D 3-wire extension cord.

6.02 To prevent power loss and overheating, 2-wire extension cords for the C impact wrench shall be 16-gauge minimum for lengths up to 50 feet, and 14-gauge minimum for lengths up to 100 feet.

7. SAFETY PRECAUTIONS

- 7.01** Check the voltage of the power source. Do not plug in the wrench if the voltage is not 115V.
- 7.02** Always wear eye protection.
- 7.03** Always switch off the wrench and allow it to stop before reversing the direction of rotation.
- 7.04** When changing the direction of rotation, make sure that the reverse cap (Fig. 1) is turned as far as it will go or reversing switch (Fig. 2 and 3) is fully operated.
- 7.05** Do not push the bit into the wood; let the lead screw pull it.
- 7.06** Keep away from water and gas pipes or electric power lines when operating the wrench.
- 7.07** Be careful that clothing does not become entangled in the turning bit or socket.
- 7.08** Always disconnect the cord from the power source before lubricating or checking the wrench.
- 7.09** Do not press the trigger switch until the wrench is in working position. Be sure the direction of chuck rotation is correct for the work. Position the wrench so the socket fits squarely on the nut, not at an angle. Hold the wrench firmly, with a slight forward pressure, during the operation.
- 7.10** Never use any part of the tool as a hammer or lever. Breakage, misalignment, or other extensive damage will result.
- 7.11** Never insert an object through the ventilating slots to hold or lock the fan. This will cause fan damage or motor failure.
- 7.12** Always check the shank to make sure it is not bent out of line with the B socket (Fig. 2). The B socket should be checked for excessive wear. If the B socket shows excessive wear, replace the B socket.
- 7.13** Do not overload the wrench or continue to use it if it is not functioning properly.