

HEIGHT AND DISTANCE ESTIMATING DEVICES

CONTENTS	PAGE
1. GENERAL	1
2. RANGE FINDER	1
3. B HEIGHT FINDER	3
4. CLEARANCE MEASURING LINE	6
5. B CLEARANCE RULE	7

1. GENERAL

1.01 This section covers the description and use of the following:

- Range Finder
- B Height Finder
- Clearance Measuring Line
- B Clearance Rule

1.02 This section includes information formerly contained in Sections 081-220-150, 620-255-601, 620-255-602, and 620-255,611, which are canceled.

2. RANGE FINDER

DESCRIPTION

2.01 The Range Finder employs an optical system with a 6-inch base length. A prism at the eyepiece end of the instrument permits measuring vertical distances while holding the instrument horizontally. The optical system is encased in an 8-1/4 inch long metal housing, with a neckband attached (Fig. 1).

2.02 The Range Finder dial is calibrated for measuring distances between 8 and 100 feet. Accuracy of the instrument is greatest at distances

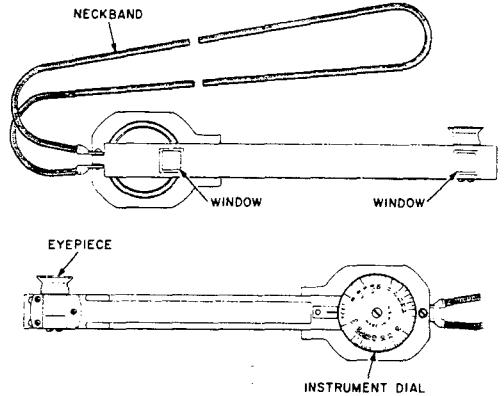

Fig. 1—Range Finder

of 30 to 40 feet, where the error is within ± 3 percent.

USING RANGE FINDER

2.03 Rotate the dial to infinity (∞) mark. Hold the instrument so that the two windows face toward the object to be measured. View the object through the eyepiece, where two images will be seen in the square center portion of the eyepiece (Fig. 2). Slowly rotate the dial clockwise until the two images are in alignment. If the dial is turned too far clockwise, turn the dial counterclockwise past the point where the images are coincident, and again turn the dial slowly clockwise until the two images are in alignment. Following this procedure of approaching coincidence of the images from the left (clockwise) each time will avoid errors in reading that may be encountered from any backlash within the Range Finder.

CHECKING ACCURACY

2.04 Check the accuracy of the Range Finder periodically for accuracy by measuring off a

**Reprinted to comply with modified final judgment.

NOTICE

This document is either
AT&T - Proprietary, or WESTERN
ELECTRIC - Proprietary

Pursuant to Judge Greene's Order of August 5, 1963, beginning on January 1, 1964, AT&T will cease to use "Bell" and the Bell symbol, with the exceptions as set forth in that Order. Pursuant thereto, any reference to "BELL" and/or the BELL symbol in this document is hereby deleted and "expunged".

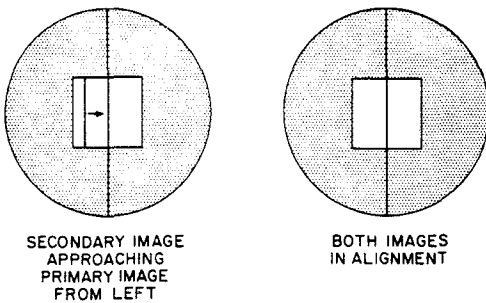

Fig. 2—Aligning Range Finder Image

horizontal distance of 35 feet from a vertical object, such as a pole or building. Sight horizontally on this object, and bring the double image into coincidence, as described in 2.03. If the dial indication exceeds ± 1 foot from the 35-foot mark, return the instrument for repair according to local instructions.

CARE OF RANGE FINDER

2.05 Handle the Range Finder carefully to avoid damage which may affect the accuracy of the instrument. If the instrument is dropped or otherwise subjected to shock, check accuracy as described in 2.04 before using again.

MEASURING GROUND CLEARANCE

2.06 When making measurements of overhead wires or cable, stand directly beneath the observed wire or cable and hold the Range Finder at a right angle to the object being measured, as illustrated in Fig. 3. Be sure to add height of eye to value indicated on dial.

MEASURING VERTICAL SEPARATION OF CROSSOVER

2.07 It is imperative that measurements of vertical separation of aerial plant be made from a point *directly beneath* the crossover point. One method of determining the point of crossing with acceptable accuracy is as follows:

- (a) From point A beneath the lower wire, at least 20 feet from a point that appears to be beneath the crossover, sight along the bottom wire and observe the spot that appears to be

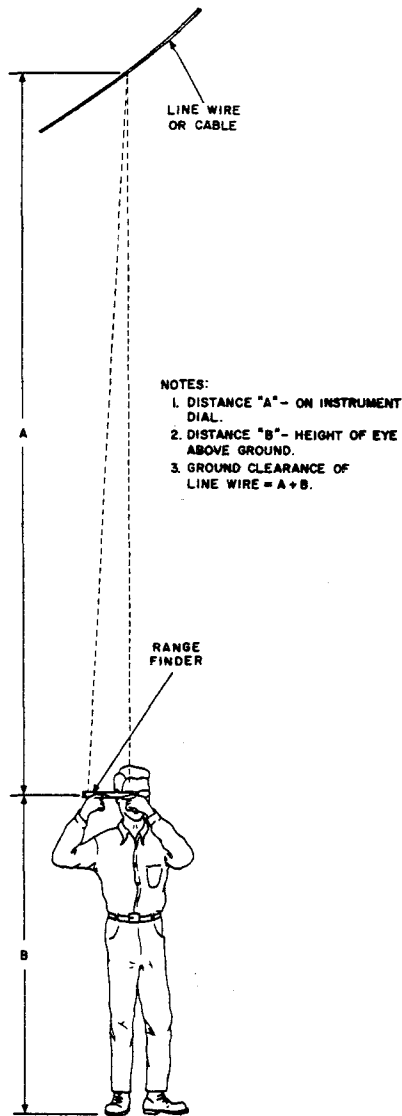

Fig. 3—Measuring Ground Clearance With Range Finder

directly beneath the crossover point *C* (Fig. 4). Place a mark on the ground at this point, return to point *A*, and verify the position marked on the ground.

(b) From point *B* beneath the top wire, at least 20 feet from a point that appears to be beneath the crossover, sight along the top wire and observe the spot that appears to be directly beneath the crossover point *C*.

(c) Repeat the process until the two points *C* coincide.

2.08 After establishing the point directly beneath the crossover, make vertical measurement of the top, then the bottom wire or cable. Subtract the height of the bottom wire from the height of the top wire; the difference is the vertical separation of the wires.

MEASURING VERTICAL SEPARATION OF PARALLEL WIRES

2.09 When measurements involve open wire, it is preferable to select wires at the outer end of a crossarm, to avoid confusion when making the measurement. Stand aside from the vertical plane of the two wires or cables being measured just enough to permit viewing each wire being measured (Fig. 5).

3. B HEIGHT FINDER

DESCRIPTION

3.01 The B Height Finder is an inexpensive, imprecise instrument which may be used to estimate heights of poles and attachments, clearances between wires or cables, and ground clearances. The instrument uses the principle of triangulation

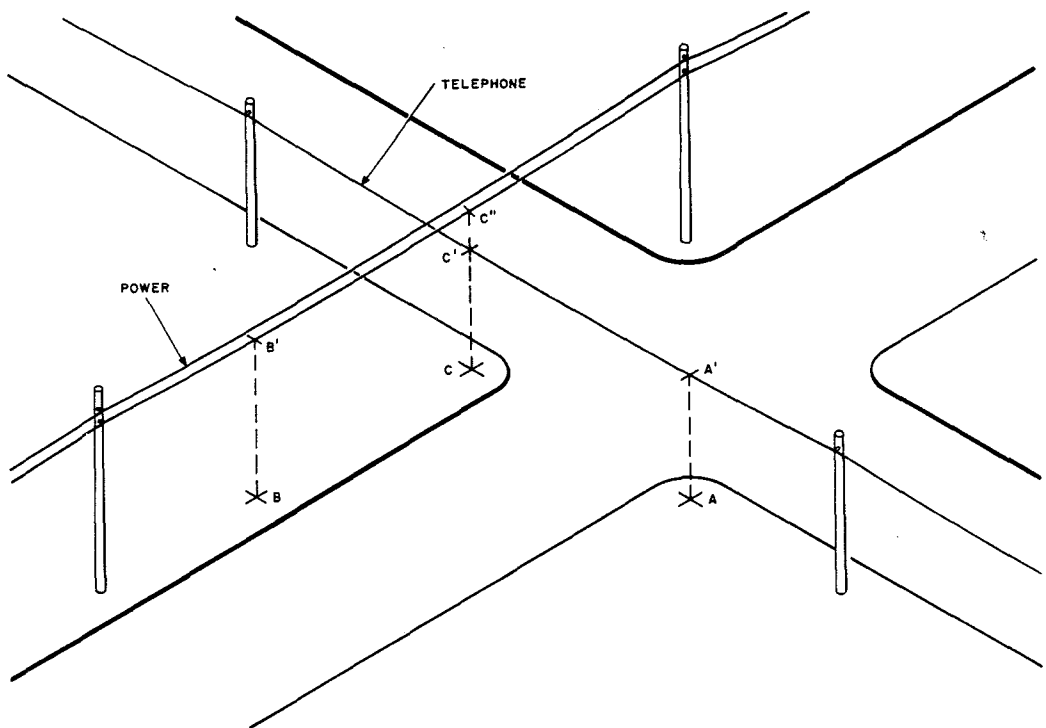

Fig. 4—Measuring Vertical Separation With Range Finder

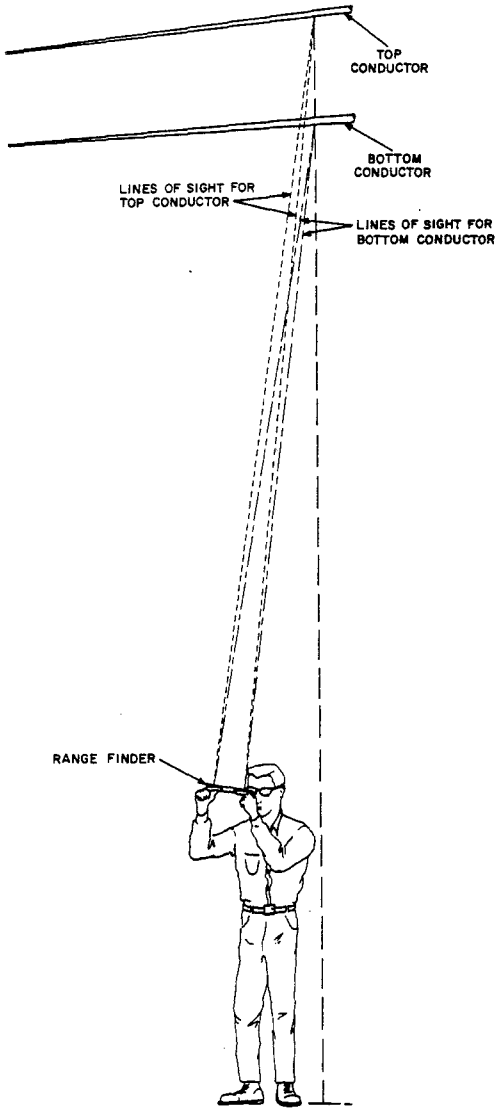

Fig. 5—Measuring Vertical Separation of Parallel Wires With Range Finder

and provides readings to an accuracy of approximately ± 10 percent within the range of the instrument. More accurate readings may be obtained by averaging several carefully taken readings. When an error of 10 percent could mean the difference between safe and unsafe conditions, such as measuring the clearance between power and telephone cables, another method should be used.

3.02 The B Height Finder consists of a white plastic strip 8-1/4 inches long, 1-3/4 inches wide, and 3/16-inch thick (Fig. 6). A dual scale is provided. On one edge the calibration is 0 to 26 feet in 1-foot increments; the opposite edge is calibrated 0 to 40 feet in 1-foot increments. The baselines (distance away) for the measurements are 60 and 90 feet, respectively. A metallic-bead chain is attached near each end of the scale to provide a viewing distance of 15 inches from the eye, and to assist the user in holding the height finder perpendicular to the baseline. An envelope-type leather case is provided for carrying the finder.

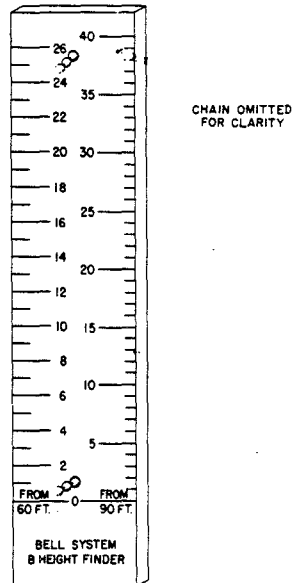

Fig. 6—B Height Finder

3.03 Check to be sure the base length of chain from the scale to the connecting link is 15 inches before using.

MAKING HEIGHT MEASUREMENT

3.04 Measure off 60 or 90 feet from the base of a pole. At this point, hold the connecting link end of the chain between the index finger and thumb, as shown in Fig. 7. Using the index finger place the connecting link against the cheekbone. Sight along the appropriate edge of the scale, lining up the zero line of the scale with the bottom of the pole (Fig. 8). Without moving the scale, sight along the scale where it intersects with the top of the pole or attachment being measured. This point on the scale indicates the height of the object being measured. *Be sure to use the proper scale for the measured baseline.*

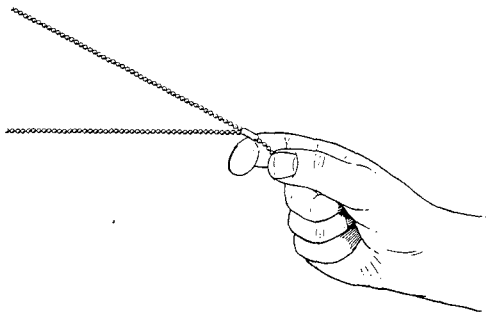

Fig. 7—Holding B Height Finder Chain

3.05 If the bottom of the pole is obscured by shrubbery or undergrowth, place a mark on the pole at about eye level. Use this mark as the zero reference, and make the measurement as given in 3.04. Add the height indicated on the scale to the height of the mark on the pole to obtain height above ground.

MEASURING VERTICAL CLEARANCE

3.06 To find the clearance between two wires or attachments on a pole, measure off a 90-foot baseline. (The 90-foot baseline is more accurate for measuring clearances). Sight along the 90-foot edge of the scale, aligning the lower object with

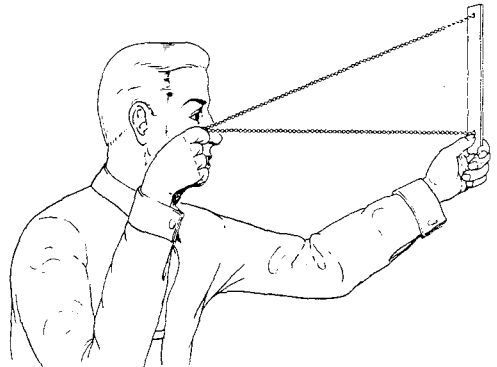

Fig. 8—Sighting With B Height Finder

the zero line on the scale. Without moving the scale, sight along the scale to the upper object and read the separation between the two objects.

3.07 To find the clearance between wires in a crossover, establish a point on the ground directly under the crossover, as described in 2.07. Mark this point on the ground with a pole stake or a short, pointed stick. Measure off a 90-foot baseline and make the measurement as described in 3.06, using the pole stake as an orientation point (Fig. 9).

3.08 If the ground in the area of the orientation point is obscured by brush or shrubbery, use a digging bar, range rod, or similar object to mark the orientation point.

3.09 To measure clearance above ground, establish a point on the ground directly beneath the object being measured and place a pole stake or stick as an orientation point (Fig. 10). If the orientation point is obscured by shrubbery or brush, use a digging bar, range pole, or similar object to mark the orientation point. Measure off a 60- or 90-foot baseline and take reading as previously described. Add the height of digging bar or other object, if used, to the reading obtained.

MEASURING GUY WIRE

3.10 Measure off a 60- or 90-foot baseline as previously described. Using the appropriate scale, align the guy anchor with a horizontal line

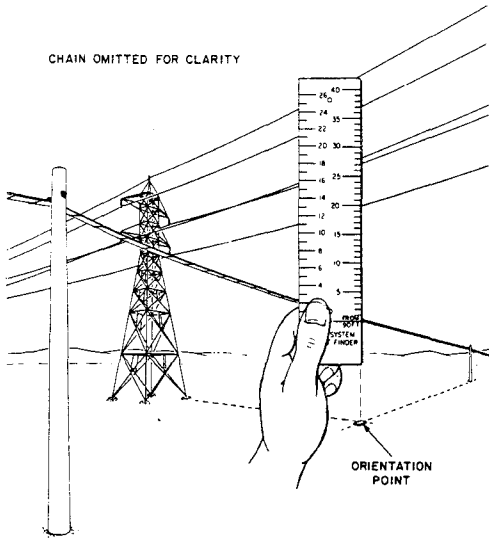

Fig. 9—Measuring Vertical Clearance With B Height Finder

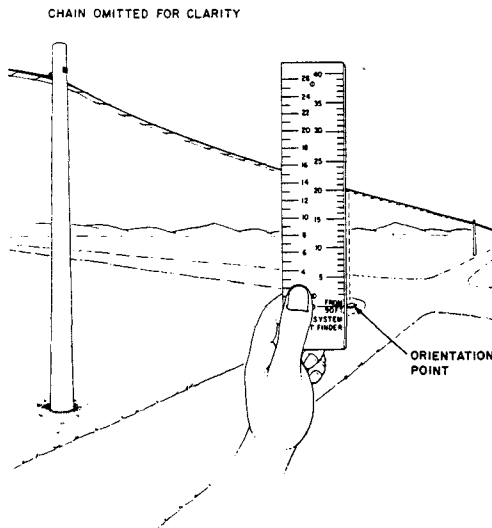

Fig. 10—Measuring Ground Clearance With B Height Finder

to the zero line on the scale. Without moving the Height Finder, sight along the edge of the scale to the guy bolt (Fig. 11).

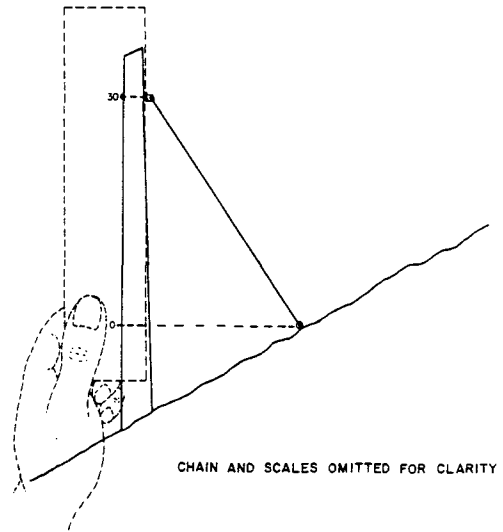

Fig. 11—Measuring Guy Wire Attachment With B Height Finder

MEASUREMENTS OVER 40 FEET

3.11 If it is necessary to make vertical measurements greater than 40 feet, double the baseline and the value read on the scale. Thus, the maximum height would be 80 feet and the baseline 180 feet.

4. CLEARANCE MEASURING LINE

DESCRIPTION

4.01 The Clearance Measuring Line is an inexpensive device for measuring height of drop wires over streets, highways, or driveways to obtain proper clearances (Fig. 12).

4.02 The Clearance Measuring Line consists of a length of mason's line attached to a rubber bobbin on one end and a spring clip on the other end. The line is 18 feet long between the bobbin and the clip. *Do not use this device to measure*

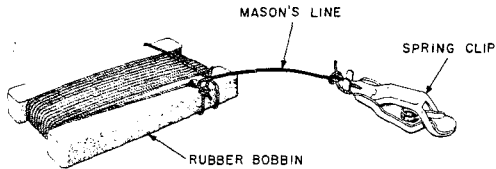

Fig. 12—Clearance Measuring Line

power lines or lines where there is a possibility of contact with power lines.

Warning: *Wear eye protection and hard hat when using Clearance Measuring Line.*

4.03 Attach drop wire to building. Unwind line from bobbin and attach clip at a point on the drop wire where the line will not interfere with pedestrian or vehicular traffic, or become entangled in trees. Make attachment to pole, applying sufficient tension to obtain proper sag, using the Clearance Measuring Line to obtain required road clearance (Fig. 13). If, because of traffic or trees, the clip cannot be attached to the low point of the span across a road, estimate the difference in elevation and pull the drop wire up until the bobbin is at least an equivalent distance above ground (Fig. 14).

4.04 If the surface where clearance is measured is above or below the high point of the road, make allowance for the difference in elevation of these points as well as for the difference in elevation as described in 4.03.

4.05 Remove the spring clip by pulling steadily on the line from a point not directly beneath the clip. **Do not jerk on line or look up while disengaging clip.**

MEASURING EXISTING DROPS

4.06 Select a location as close as possible to the low point in the span over roadway but not in the path of traffic.

4.07 Unwind the line from the bobbin. Stand beneath the drop wire and hold the clip in one hand and toss the bobbin over the wire with the other hand (Fig. 15). **Be sure that line will not contact or cross over power lines.** Do not toss bobbin from a position to the side of the wire,

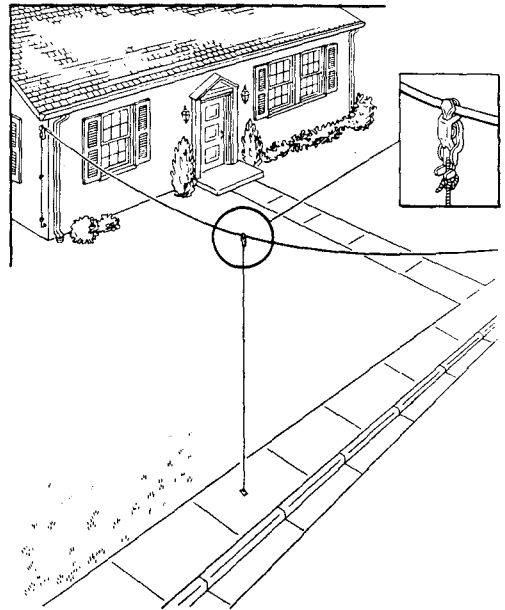

Fig. 13—Measuring New Drop With Clearance Measuring Line

as the bobbin will have a tendency to wrap the line around the wire.

4.08 Move away from under the wire about 5 feet and pull the bobbin up level with the wire.

4.09 Check clearance with the line, then release the line to permit the bobbin to fall. If bobbin does not fall when line is released, flip the line to start bobbin moving. Rewind line on bobbin.

4.10 Where trees or other obstructions prohibit checking clearance as outlined in 4.09, check clearance at a convenient point out of the way of vehicular traffic, as described in 4.03, making allowance for differences in elevation.

5. B CLEARANCE RULE

GENERAL

5.01 The B Clearance Rule is the most accurate of any of the devices described herein for

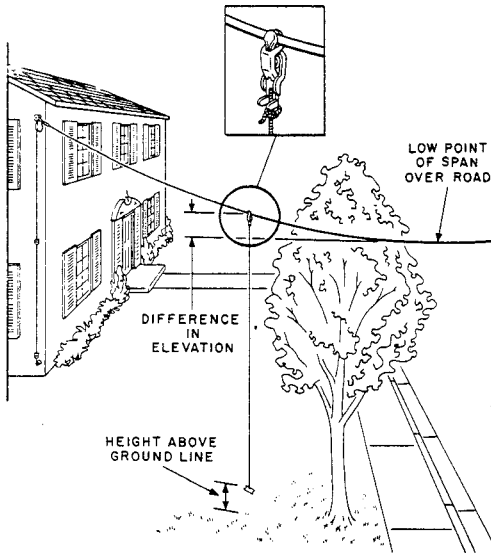

Fig. 14—Measuring New Drop With Obstructions in the Way

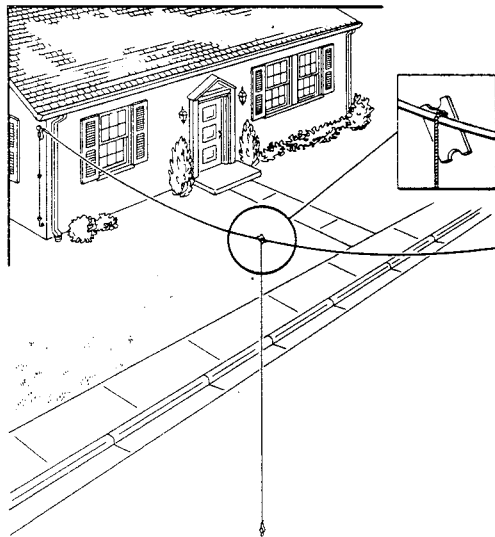

Fig. 15—Measuring Existing Drop With Clearance Measuring Line

measuring vertical clearances of aerial plant, and is capable of producing readings with accuracies better than ± 1 percent. It is made of electrically nonconductive fiberglass tubing, and is at present *the only device approved for measuring vertical clearances of, or in the proximity of, power lines.*

DESCRIPTION

5.02 The B Clearance Rule consists of six lightweight bright yellow fiberglass tubes which are marked in black at half-inch intervals (Fig. 16). Inch and foot markings are arranged so that heights are read at the top of the bottom section. Each section is equipped with a positive stop mechanism consisting of a short, spring-driven nylon button which fits into a matching hole in the next larger tube. The rule weighs approximately 3 lbs. The rule has a collapsed length of 5 feet and may be extended to 25 feet. Heights up to about 28 feet can be measured with minimum loss of accuracy.

5.03 The rule has a dielectric strength of 100,000 volts per foot when new. Although the insulation is adequate, it can be affected by dirt and moisture. Where use of this tool is likely to involve contact with energized power facilities, it must be clean and dry. A dry or moist cloth should be adequate to remove most foreign materials; alcohol, xylene, or detergents may be necessary to remove grease, tar, etc.

PRECAUTIONS

5.04 *When energized power conductors are present and are within reach of the rule, the rule must be clean and dry before attempting to make measurements. Do not use the rule in the vicinity of power conductors in rainy or foggy weather, when snow is falling, or salt spray is present. Make sure the rule is free of mud, grime, and other foreign matter before using it in any situation where it may contact power conductors.* The B Clearance Rule may be used without regard to rain, drizzle, or fog if there are no energized power facilities within reach of the extended rule.

5.05 When measuring clearances between telephone plant and energized power facilities, or when the rule may accidentally contact energized power facilities, *keep at least 4 feet clearance* of the rule between the point of contact and the hand

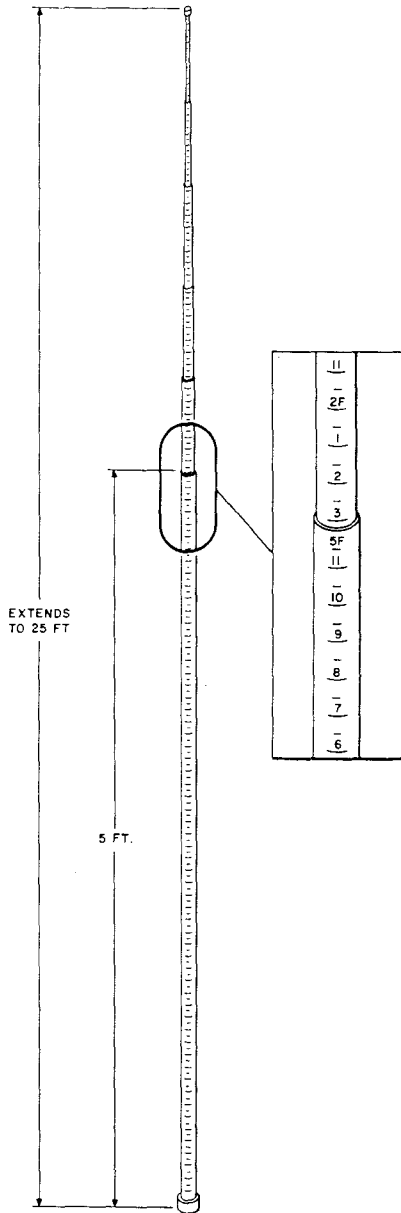

Fig. 16—B Clearance Rule

nearest the power facility (Fig. 17). Always use the smallest diameter section of the rule to contact power facilities.

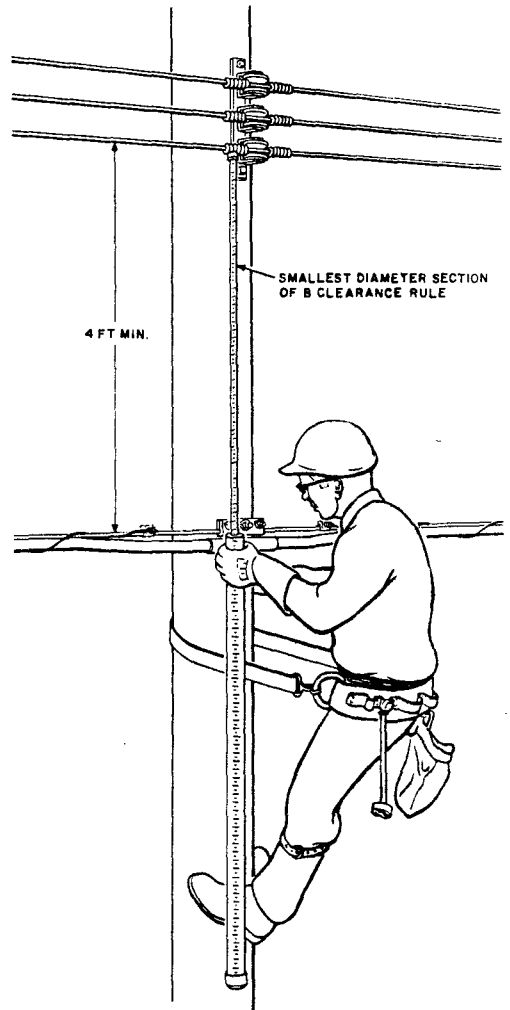

Fig. 17—Measuring Clearance Between Telephone Plant and Power Wires With B Clearance Rule

5.06 *Do not climb into the power space on the pole.*

5.07 When using the B Clearance Rule aloft, be especially careful to avoid dropping the rule. Raise and lower the rule by using a handline or carry it aloft in a Telsta or similar lift. **Do not throw or drop the B Clearance Rule from aloft.**

5.08 Be especially careful when using the rule in high winds to avoid losing control and letting the rule drop on pedestrians or vehicular traffic.

USE

5.09 The B Clearance Rule is used for measuring clearances of aerial telephone plant, both above ground and below foreign wires, cables, and power conductors. Extend rule by pulling the smallest section out as far as it will go. If it does not lock in place, rotate the smallest section within the adjacent section until the nylon button snaps into the matching hole. Repeat this procedure successively with the next largest section until the desired length is obtained.

5.10 With the rule extended and approximately vertical, bring it into contact with the object being checked. With the bottom of the rule firmly on the ground, press the nylon button at the top of the bottom section and let the upper parts of the rule slide until the tip just touches the underside of the wire being measured. Read the rule where the top edge of the bottom section intersects the adjacent section (Fig. 18).

5.11 Although the rule is only 25 feet long, measurements of heights up to about 28 feet can be made with little loss of accuracy. The basic procedure remains the same in that the tip of the rule is brought into contact with the underside of the wire being measured. However, it is necessary to raise the bottom of the rule off the ground (Fig. 19). If a second craftsman is present, he should measure the distance from the bottom of the rule to the ground with a steel tape, folding

rule, or other suitable means. Add this measurement to 25 feet.

5.12 If a second craftsman is not present, use the following procedure:

- (a) Raise the rule into contact as before.
- (b) Position the lower hand just above or just below the one-foot or two-foot mark on the bottom section, whichever is more convenient.
- (c) Keep the arm in the lower position as close to the body as possible, preferably with the forearm horizontal.
- (d) Keep the hand in the lower position steady and let the rule slip slowly until the bottom rests on the ground.
- (e) Note the position of the lower hand on the scale. This reading, less one or two feet, depending on the initial position is the distance to add to 25 feet to obtain the height of the object being measured.
- (f) Repeat the entire measurement. The second measurement should not differ from the first by more than one inch. If they do, take a third measurement. Average the two measurements which agree to within one inch and round off to the nearest inch.

Caution: *Do not raise the bottom of the rule more than waist high; the rule becomes difficult to control and measurements tend to become unreliable.*

MAINTENANCE AND STORAGE

5.13 The B Clearance Rule needs no maintenance other than cleaning. Use a clean, dry cloth for general cleaning. Use a clean cloth moistened with detergent and water, xylene, or alcohol to remove foreign materials such as grease or tar, then wipe clean and dry. Store in a dry place.

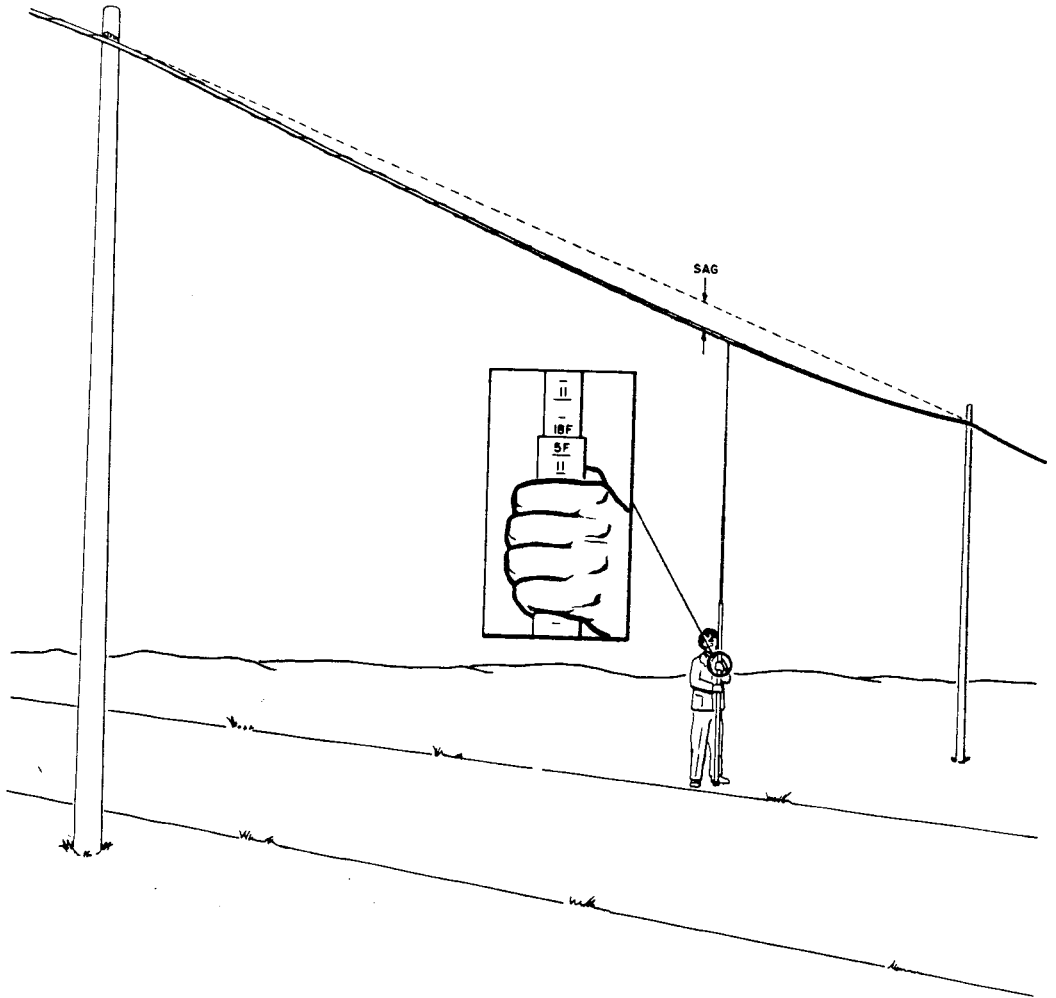

Fig. 18—Measuring Ground Clearance With B Clearance Rule

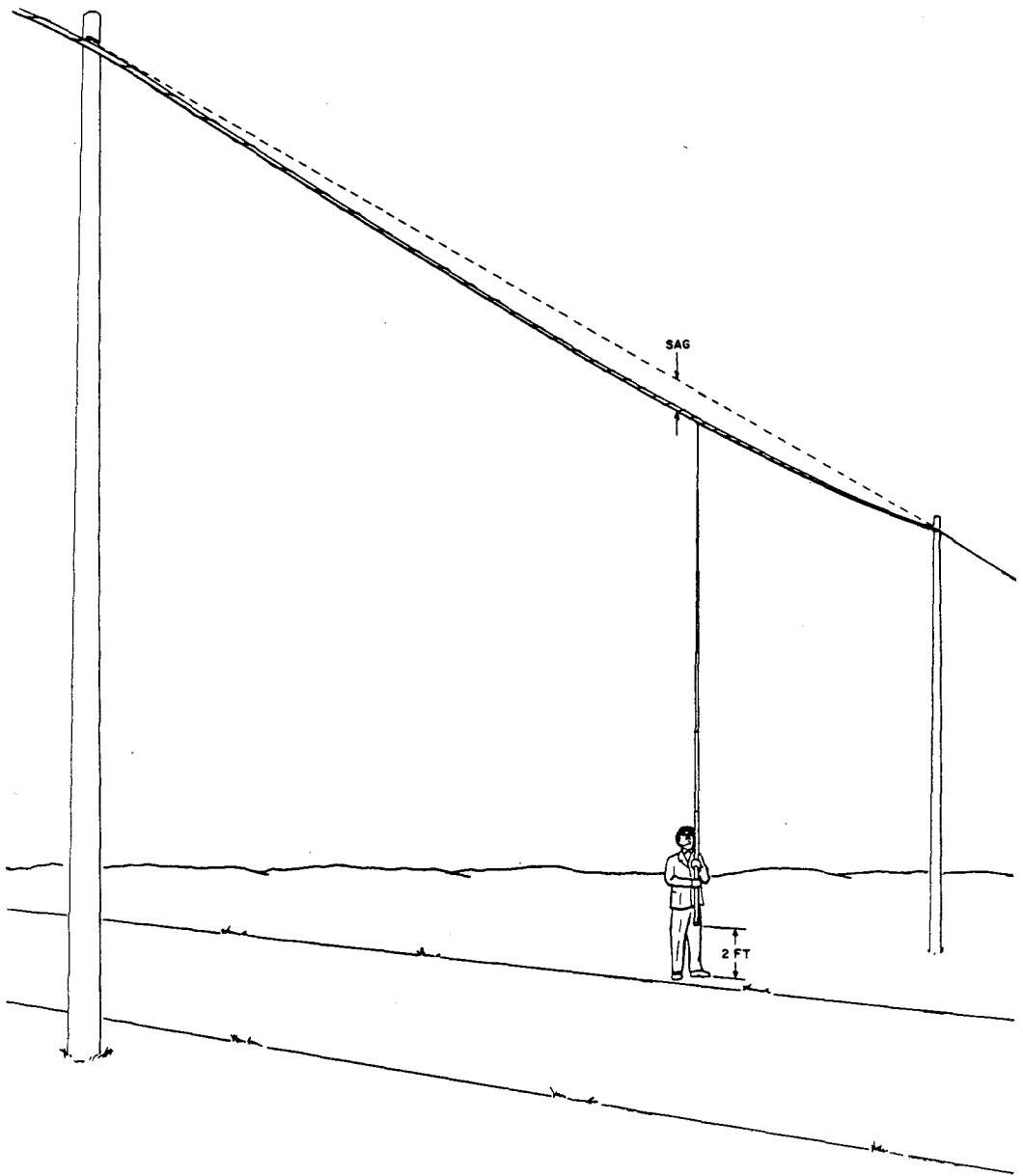

Fig. 19—Making Measurement Greater Than 25 Feet With B Clearance Rule