

B LP-GAS TENT HEATERS

DESCRIPTION AND USE

	CONTENTS	PAGE
1.	GENERAL	1
2.	DESCRIPTION	1
3.	PRECAUTIONS	1
4.	OPERATION	2
5.	MAINTENANCE	3
6.	SUPERSEDED LP-GAS TENT HEATERS	3

1. GENERAL

1.01 This section covers the description and use of the B LP-Gas Tent Heaters which are used for heating the interior of aerial tents. Also outlined are the precautions that should be followed in using the heaters.

1.02 This section is reissued to update Fig. 2 and to make minor text changes.

1.03 Information is also included to cover the superseded 2000, 4000, and 8000 BTU LP-Gas Tent Heaters.

1.04 General instructions covering the use of LP-Gas operated equipment are covered in the section on LP-Gas Cylinders. The cylinders are not a part of the heater and must be ordered separately.

1.05 The operator should be familiar with Section 081-330-116, B, C, D, and E LP-Gas Cylinders prior to using a B LP-Gas Tent Heater.

2. DESCRIPTION

2.01 The B LP-Gas Tent Heaters consist of outer and inner cylinders with supporting chains, control valve, burner manifold attached to bottom plate assembly, 30 feet of low pressure gas

hose and a preset low pressure regulator. The 4,000, 8,000, and 12,000 BTU heaters have one, two, and three burner jets, respectively. Fig. 1 illustrates the 4,000, 8,000, and 12,000 BTU heaters.

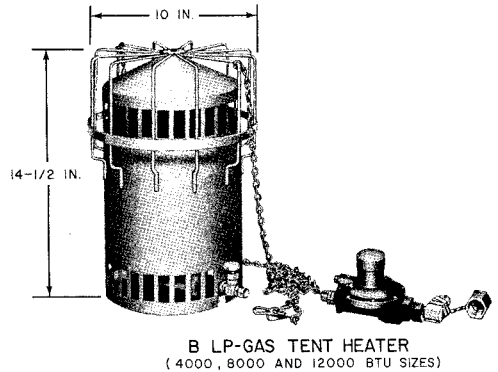

Fig. 1—B LP-Gas Tent Heater

3. PRECAUTIONS

3.01 When using these tent heaters, the following precautions should be observed:

(a) Adequate ventilation should be provided in tents, particularly the vinyl coated types.

(b) The Bastian Blessing Company's Rego No. 12555A or an equivalent low pressure regulator should be used. These regulators are preset by the factory to furnish LP-Gas to the heaters at a pressure of about 6 ounces. The superseded heaters were furnished with either the Rego No. 2303 or Roney No. 60 regulators.

NOTICE

This document is either
AT&T - Proprietary, or WESTERN
ELECTRIC - Proprietary

Pursuant to Judge Green's Order of August 5, 1983, beginning on January 1, 1984, AT&T will cease to use "Bell" and the Bell symbol, with the exceptions as set forth in that Order. Pursuant thereto, any reference to "BELL" and/or the BELL symbol in this document is hereby deleted and "expunged".

- (c) Avoid contact with the hot upper half of the heater.
- (d) Keep the hot upper half of the heater away from the safety strap, clothes, tent fabric, shoes, wood, rope, etc.
- (e) Flammable materials such as wire clippings, kerosene soaked cloths, etc, must be kept away from the hot upper half of the heater.
- (f) The heater should be turned off and hung from the strand outside the tent or lowered to the ground before hot paraffin is brought into the tent. After the boiling out operation, the tent shall be ventilated before the heater is brought into the tent and relighted.
- (g) The heater *must not be used in a manhole, or above a manhole in a manhole tent.*

3.02 Leaky connections are dangerous and wasteful of LP-Gas. Large leaks may be detected by the odor of escaping gas. The tent heater should be tested as follows: Connect the regulator to the cylinder, turn off the valve at the tent heater and open the cylinder valve. The regulator and tent heater connections and control valve should be checked for leaks with pressure testing concentrate or other suitable solution. Exercise care not to get the solution on the face of the regulator. The hose should be immersed in water to test for leaks. *Never test for leaks with an open flame.* No attempt should be made to repair a leak other than to tighten connections.

3.03 Do not attempt to adjust or repair the regulator. Examine the vent in the regulator to ensure that it is free of foreign material. If the regulator does not function properly, tag and return it in accordance with local instructions.

3.04 Keep the cylinder valve closed when the tent heater is not in use.

4. OPERATION

4.01 Connect the low pressure regulator to the LP-Gas cylinder. Connect one end of the E Pressure Hose to the pressure regulator and the other end to the valve control on the tent heater (Fig. 2). Using the B or C Regulator Wrench tighten connections on the regulator and hose.

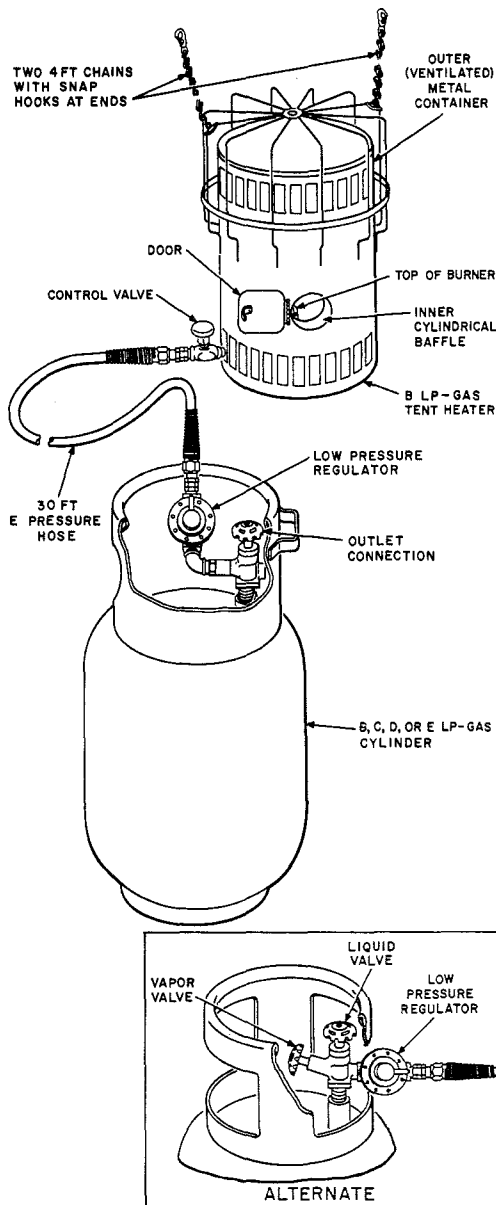

Fig. 2—Heater Connected to Cylinder

4.02 Close the control valve on the heater and then suspend the heater in the desired position by attaching the 4 foot supporting chains over the strand (Fig. 3).

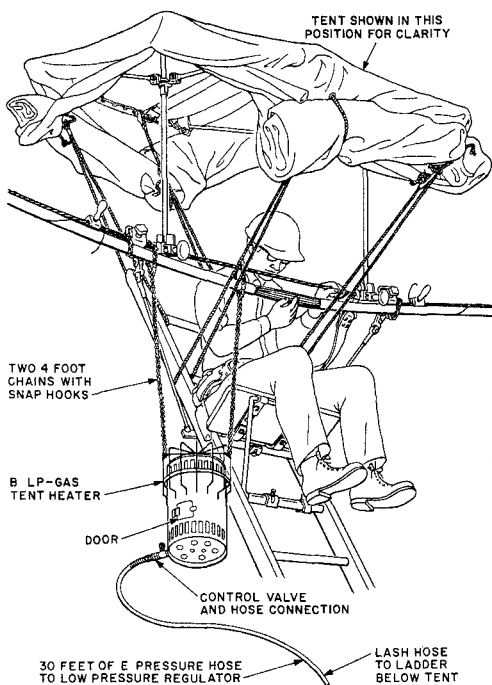

Fig. 3—Heater Attached to Strand

4.03 When ready to light the heater, open the valve on the LP-Gas cylinder. If a double valve is used, open the vapor control valve. **Make sure that the liquid control valve is closed.** Test all connections for escaping gas in accordance with 3.02. Open the small door and rotate control valve on tent heater approximately 1/4 turn, ignite gas with a match or Shoot-A-Lite held near the

burner. Close the door and open the control valve to its full open position. When less heat output is desired, adjust the control valve to produce a lower flame.

4.04 When the burner unit is warming up an occasional luminous yellow tip may be seen at the ends of the flame.

4.05 When the burner is fully on, the rush of air being drawn into the burner creates an audible hiss, which decreases in volume if the control valve is at a lower setting.

4.06 A strong odorant in the LP-Gas can be detected any time gas is escaping or if the flame should go out. **In this event, close the control valve immediately and ventilate the tent thoroughly before relighting the burner.**

4.07 Turn the heater off before leaving the tent by closing the control valve. The valve on the LP-Gas cylinder should also be turned off when tent heater is not in use.

5. MAINTENANCE

5.01 When the inner and outer metal cylinders require cleaning remove bottom plate assembly from housing. Do not remove burner manifold from the bottom plate assembly. Clean the cylinders with a wire brush and reassemble bottom plate to housing. If burner jet becomes clogged, replace it. Do not attempt to clean burner jet. If heater then fails to operate properly, return for repair in accordance with local instructions.

5.02 No other maintenance shall be performed in the field except for replacing E Pressure Hose and low pressure regulator.

6. SUPERSEDED LP-GAS TENT HEATERS

6.01 The 2000, 4000, and 8000 BTU LP-Gas Tent Heaters (Fig. 4) have been discontinued. When necessary to replace heaters, the B LP-Gas Tent Heater should be ordered.

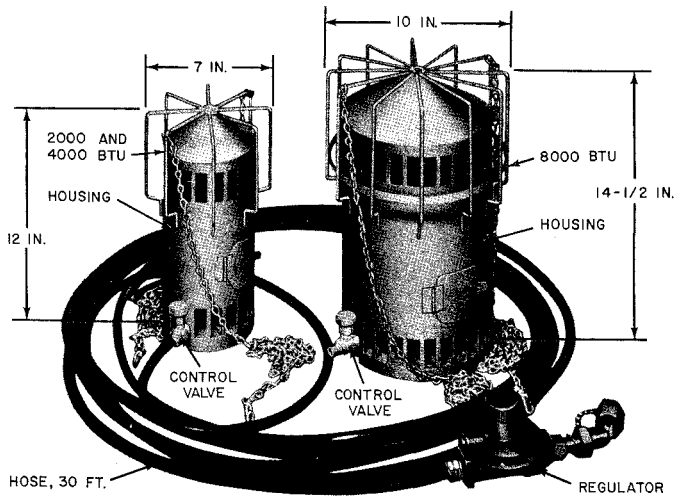

LP TENT HEATERS
(AT-7631X)

Fig. 4—Propane Tent Heaters