

**188A TEST SET
(STOP LITE)
DESCRIPTION AND USE**

CONTENTS	PAGE
1. GENERAL	1
2. PRECAUTIONS	3
3. DESCRIPTION	4
4. THEORY OF OPERATION	5
A. User Protection	5
B. Voltage Indications	5
5. OBSERVATIONS TO BE MADE BEFORE CLIMB- ING	6
6. VOLTAGE TEST AND SAFEGUARD	8
7. VOLTAGE TESTS AND SAFEGUARD ALOFT, UNDER, OR NEAR POWER TRANSMISSION LINES	12
8. DC VOLTAGE TESTING	14
9. INDUCED VOLTAGE TESTING	15
10. FOREIGN VOLTAGE REPORTING PROCE- DURES	16
11. CARE AND STORAGE	8
12. ORDERING	8

used to test objects for potentially hazardous volt-
ages. Some of the objects which can be tested are:

- Power ground wires
- Streetlight fixtures
- Cables and strand
- Mobile homes
- Metal frameworks
- Metallic conduit
- Pedestals
- Newly driven ground rods
- Homes covered with metallic siding.

1.02 This section is reissued to:

- Add test procedures, safety procedures, illus-
trations, battery replacement, and ordering
information
- Designate intervals for testing the 188A test
set
- Expand the description (Part 3) and the the-
ory of operation (Part 4).

1.01 This section covers the description and use of
the 188A test set (Stop Lite). The test set is

Revision arrows are used to emphasize significant
changes.

1.03 DANGER: Do not touch the energized object. The 188A test set (Fig. 1) is a high impedance voltage detector. It will identify voltages over 50 volts ac and 6 volts dc, regardless of current potential. The upper voltage limits that it is designed to test for are 20,000 volts 60 Hz ac and 2000 volts dc. At frequencies other than 60 Hz, the test set is less sensitive to lower frequencies and more sensitive to higher frequencies. The test set indicates when a potentially hazardous voltage is present by means of a flashing red indicator (LED). It does not indicate the actual voltage. When the test set indicates that a potentially hazardous voltage is present, the technician should notify the appropriate management center immediately (Part 10). The supervisor will determine if the indicated voltage is hazardous.

1.04 When testing ac voltage, the test set indicates a voltage potential difference between the body of the user and the object being tested. The capacitance between the test set handle and the hand of the user is part of the test circuit and affects the sensitivity of the test set. Special testing procedures are required to insure accurate indications when the user is working aloft, on a pole, or in the bucket of an aerial lift truck. (See paragraph 7.01 for details.)

1.05 When testing dc voltages, a B temporary bond must be established between the ground terminal of the test set and a **known earth ground**. Test the continuity of the B temporary bond prior to use. (See paragraph 8.03.) **Do not use the B temporary bond for bonding if it does not pass this test. Insulating gloves must be worn when placing or removing the B temporary bond.**



B Temporary Bond: The B temporary bond (Fig. 2) is used to temporarily ground a light fixture, metallic conduit, power company hardware power ground wire, or other metallic objects in the telephone company work space which could become energized if a fault developed. The B temporary bond is placed on such attachments only after the metallic object has first been tested with the 188A test set and found to be free of a voltage potential. When placed, the bond is first attached to a reliable ground source and then to the metallic object. When the work is completed, the bond is removed from the metallic object and then the ground source. Should a fault develop when the B temporary bond is in place, the insulation may overheat and smoke which should alert the employee to descend the pole immediately and avoid contact with the bonded item and the bond.

1.06 Protective gloves are not used while testing for hazardous voltages below 20,000 vac. The test set has been designed and tested to protect the user from all hazardous voltages below 20,000 volts, 60 Hz ac.

1.07 Voltages above 20,000 volts which may be present in areas such as power stations require the use of protective gloves. (See paragraph 6.01 (5).)

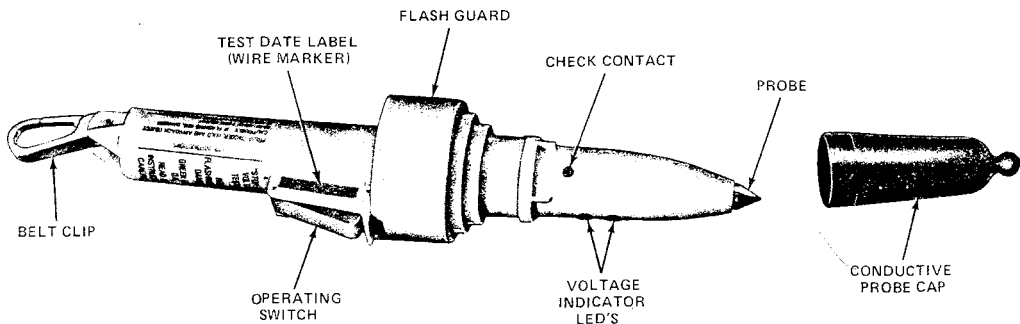

Fig. 1 — 188A Test Set

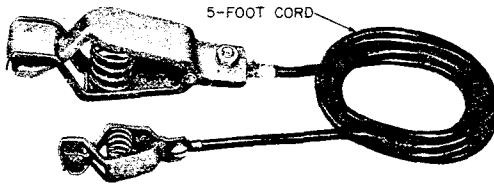

Fig. 2—B Temporary Bond

1.08 Protective gloves reduce the sensitivity of the test set. If protective gloves are worn when making a voltage test, and a hazardous voltage is indicated by the test set, **do not retest without gloves. Contact the appropriate management center (Part 10) before making additional tests.** However, if a safe condition is indicated while using protective gloves, a second test must be performed without gloves to verify the initial test result.

2. PRECAUTIONS

DANGER: Do not take unnecessary risks when potential electrical hazards are present.

2.01 Avoid dropping the 188A test set because the shock may damage the protective insulation or the internal circuitry. Return the test set immediately for testing and repair if it appears to be damaged or fails to meet the self-check test described in paragraph 6.01.

2.02 Keep the conductive probe cap over the probe end of the test set when not in use to avoid damage to the probe tip. Keep the test set clean at all times. Dirt, water, or other foreign matter can affect the insulating properties of the test set. (See paragraph 11.02.)

2.03 Before climbing a pole, make a visual observation for potential hazards. (See paragraph 5.01.)

2.04 Perform a self-check before using the set to verify that the test set is working properly. (See paragraph 6.01.)

2.05 When using the probe, keep fingers behind the flash guard at all times.

2.06 The flashguard and handle of the 188A test set are designed and tested to protect the user while testing for potentially hazardous voltages below 20,000 volts. **Do not drill, scratch, etch, use adhesive labels, or otherwise modify or deface the handle and flashguard.** Defacing or altering the 188A test set may lower or destroy the 20,000 volt ac protection afforded by the test set.

2.07 The 188A test set must be tested annually with the 1188A test set. The test set should also be tested if it has been dropped or when there are cracks or deep scratches in the handle area. See Section 081-705-103 for testing procedures using the 1188A test set. The 188A test set must be tested monthly with the 193A test set. See Section 081-705-104 for testing procedures using the 193A test set.

3. DESCRIPTION

3.01 The 188A test set is a yellow plastic two-piece unit that weighs approximately 1 pound. The front housing contains the carbide probe tip and the light emitting diode (LED) voltage indicators (one green and one red), a ground post, and a check contact (Fig. 3). The rear housing unscrews from the front and contains a belt clip and operating switch. A colored wire marker is applied to the left gusset of the operating switch. The date that the test set was last tested with the 1188A test set is written on the wire marker (Fig. 1). The flashguard is an integral part of the rear housing. Required checks before use and instructions for use are printed on a label and affixed to the handle portion of the rear housing. ♦

3.02 *C Canvas Bag (Fig. 4):* An AT-8924 C canvas bag is available to carry and store the 188A test set, B temporary bond, and W1BU ground cord.

3.03 *W1BU Ground Cord (Fig. 5):* The W1BU ground cord is a black retractile single conductor cord equipped at each end with a Mueller No. 27 clip and a black Mueller No. 29 insulator. The usable length of the cord is approximately 20 feet. The ground cord is used to provide a ground to the conductive end cap when the 188A test set is being used while working aloft.

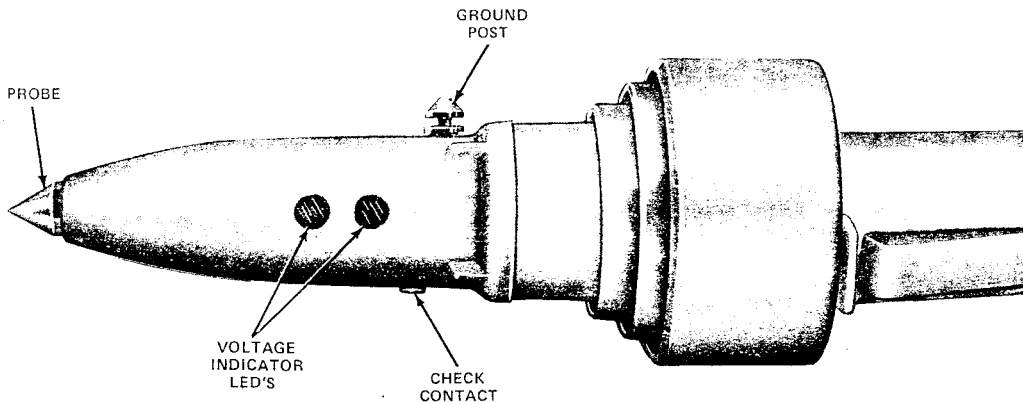

Fig. 3—Voltage Indicators

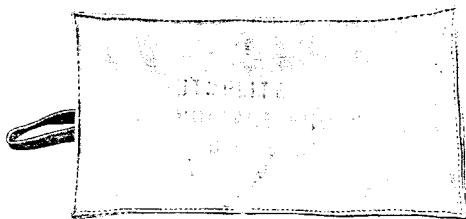

Fig. 4—AT-8924 C Canvas Bag

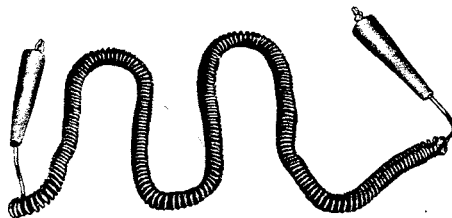

Fig. 5—W1BU Cord

3.04 Conductive Probe Cap: The conductive probe cap (Fig. 1) provides protection from the sharp tip of the probe. When placed on the handle (clip end) of the 188A test set, it provides the attachment knob for the W1BU ground cord and a conductive surface for the hand of the user.

4. THEORY OF OPERATION

4.01 The 188A test set performs two functions:

- (1) It protects the user while conducting tests for *potentially* dangerous voltages.
- (2) It indicates the presence of *potentially hazardous* voltages.

A. User Protection

4.02 The hand of the user is insulated from high voltages on the probe tip by the plastic handle of the test set. The dielectric strength of the handle is tested in the factory and should be retested annually or at any time the insulating ability of the handle becomes suspect. Any damage (cracks, engravings, melting, etc.) reduces the insulating properties of the handle. The 188A test set is used to test the dielectric strength of the 188A test set. The hand of the user is protected from high voltage flashover. Flashover is the term used for conduction over the surface

of an object that is normally an insulator. High voltage flashover is prevented by the long surface distance between the hand of the user and the tip of the test set. This distance is enhanced by the use of flashguard rings built into the test set. The surface of the test set should be kept clean and free from surface imperfections. Any foreign matter, scratches, etc. will degrade the insulating capability of the test set.

B. Voltage Indications

4.03 When a voltage greater than 50 volts is present, a potentially hazardous voltage condition exists. The red LED on the test set will flash when the operating switch is depressed. The absence of hazardous voltage is indicated by the green LED.

4.04 The presence of potentially hazardous voltage is detected by an extremely small current in a path from the high voltage source at the tip of the 188A test set, through the circuitry inside the test set, the metal tube inside the handle and the hand of the user outside the handle, and capacitive or resistive coupling between the user and ground. This current is so small that it is below the threshold of human feeling. Figure 6 is a block diagram showing this current path. Although the current in this path is miniscule, the path *must* exist for proper operation. The user

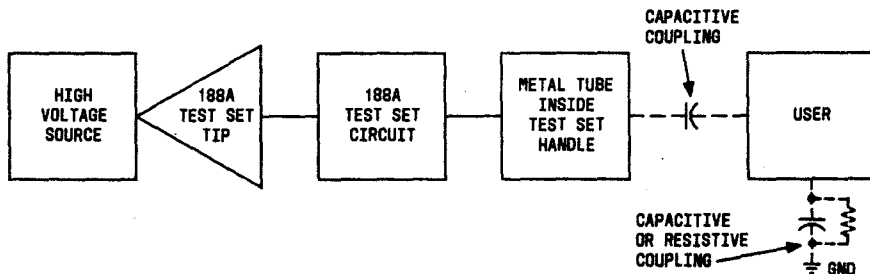

Fig. 6—Current Path

is a link in the test circuit; therefore, it is important to hold the test set properly as shown in Fig. 7. A poor grip or the wearing of gloves will make the test set less sensitive. **Any voltage induced on the body of the user through electrostatic coupling from power transmission lines is effectively in series with the voltage being tested and may cause the test set to indicate an unsafe condition when none actually exists.**

4.05 A special testing procedure, described in paragraph 9.03, is necessary to eliminate the electrostatic voltage coupled to the user from power lines. Use of the conductive probe cap and W1BU ground cord as described in paragraph 9.03 will eliminate the induced body voltage of the user. The 188A test set will then indicate only the voltage on the object being tested. Without this special procedure, the body voltage of the user may be significant. This voltage is harmless and cannot produce dangerous current; however, the voltage is often of sufficient amplitude to light the red LED on the 188A test set.

4.06 The protective 20,000 volt insulation provided by the 188A test set is not affected when the conductive probe cap is placed on the handle. The user should observe all precautions listed in Parts 5,

6, 7, and 8 and should contact the appropriate management center for further instructions.

5. OBSERVATIONS TO BE MADE BEFORE CLIMBING

5.01 DANGER: Do not contact supply wires going to a fixture. Examine the pole for potential electrical hazards (Fig. 8) such as a vertical power ground wire, vertical metallic power conduit, streetlight fixture, power company primary disconnect hardware, or other foreign metal objects. Also observe the pole and adjacent spans for such hazards as improper clearance from power conductors or equipment, dangling power wires, inadequate clearance between pole-to-pole guys and power wires, corona or electrical arcing on energized attachments, etc. If none of these are present, the pole may be climbed providing no mechanical hazards are evident.

5.02 If a vertical power ground wire is present, make a voltage test in accordance with Part 6 before climbing or working on the pole unless it meets any one of the conditions illustrated in Fig. 9.

5.03 If a vertical metallic power conduit or other power company hardware extends to the base of the pole, make a voltage test in accordance with Part 6 before climbing or working on the pole.

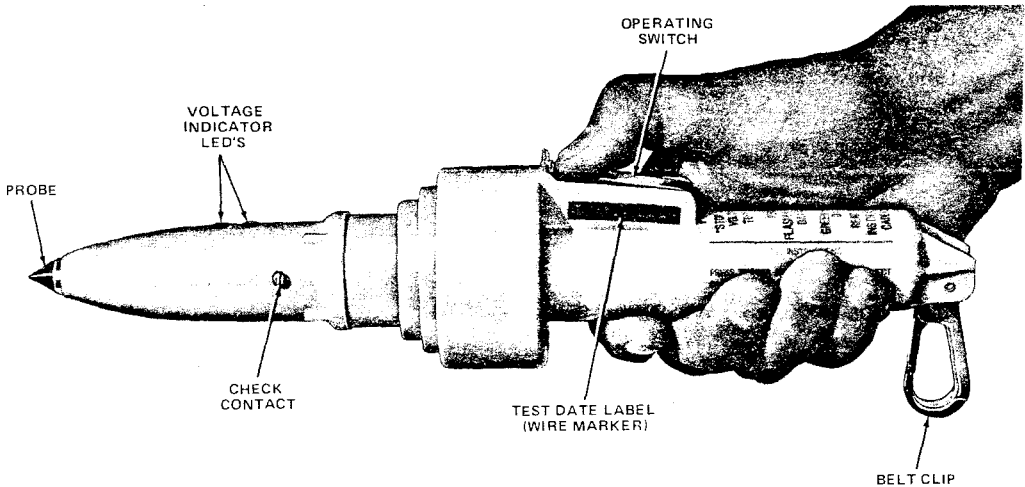
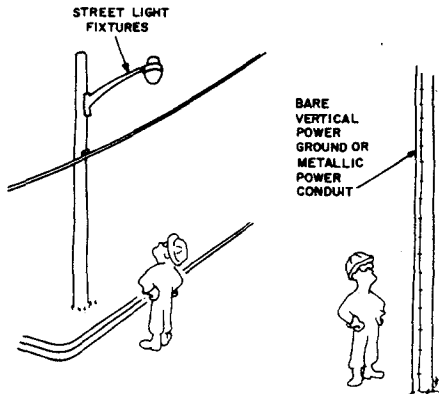
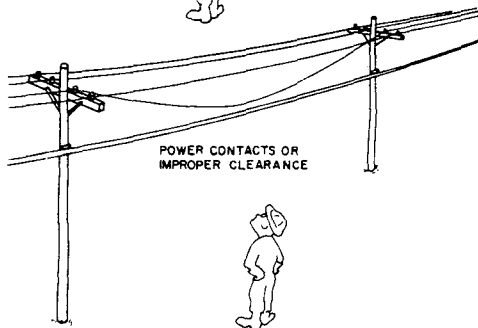
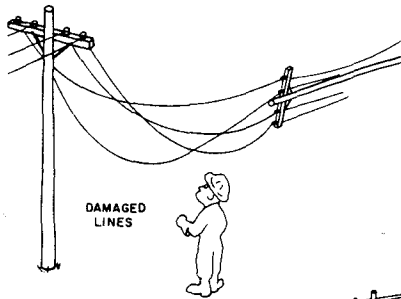

Fig. 7—Proper Grip of 188A Test Set



USE VOLTAGE TESTER WHEN REQUIRED



NOTIFY SUPERVISOR DO NOT CLIMB

Fig. 8—Visual Inspection for Potential Electrical Hazards

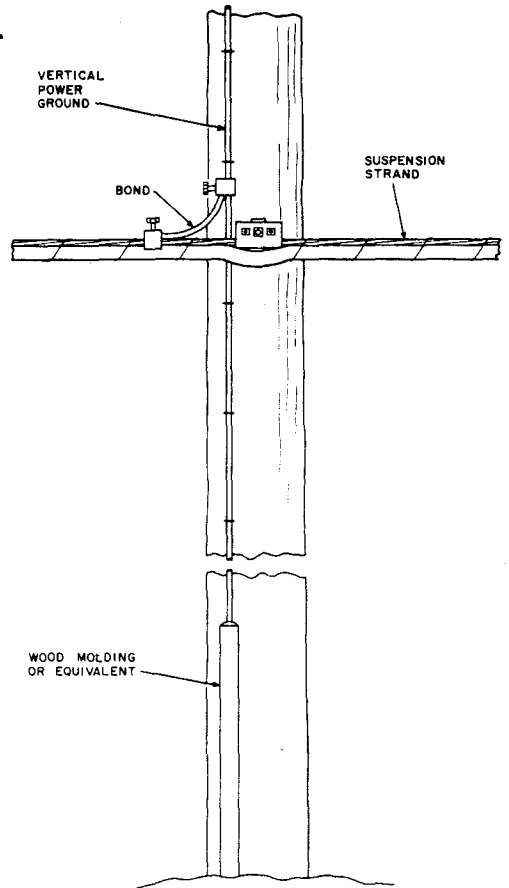

NOTES:

1. NO TEST REQUIRED IF:
 - A. COVERED BY UNDAMAGED INSULATION
 - B. WOOD MOLDING EXTENDS THROUGH TELEPHONE COMPANY SPACE.
2. IN ALL OTHER CASES TESTER MUST BE USED.

Fig. 9—Vertical Power Ground—Not Requiring Use of 188A Test Set

5.04 When a pole carries multiple line wire, telephone cable, or a bare vertical power ground wire and a streetlight fixture (Fig. 10), test in accordance with Part 7.

5.05 If an ungrounded streetlight fixture is present, is less than 40 inches above or below telephone attachments, and is on a pole not carrying a telephone cable or a bare vertical power ground wire, wear insulating gloves and avoid contact with it or its wiring since it is not possible to place a temporary bond to an effective ground.

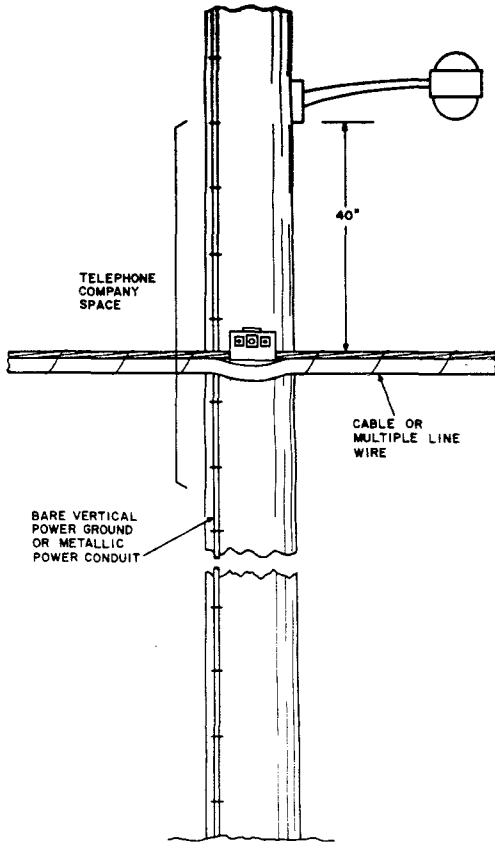

NOTE:
 VOLTAGE TEST REQUIRED IF
 POLE ALSO CARRIES:
 A. TELEPHONE CABLE
 B. MULTIPLE LINE WIRE
 C. BARE VERTICAL POWER GROUND
 D. METALLIC POWER CONDUIT
 E. FIXTURE NOT BONDED TO STRAND

Fig. 10—Streetlight Fixtures Requiring Use of 188A Test Set

5.06 Voltage tests are not required at poles with streetlight fixtures as illustrated in Fig. 11.

6. VOLTAGE TEST AND SAFEGUARD

6.01 Figure 12 provides test procedures for the 188A 'Stoplite' test set. Paragraphs 6.02 through 6.14 provide procedures for testing specific facilities.

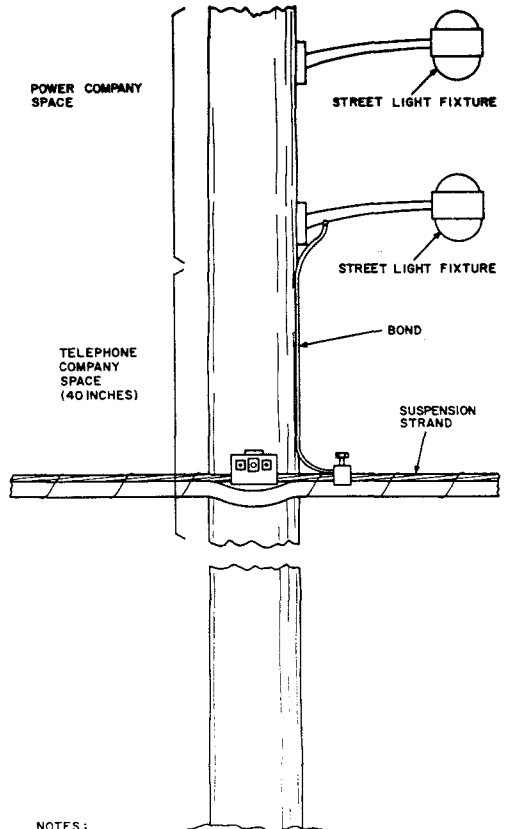

NOTES:
 1. NO TEST REQUIRED IF:
 A. FIXTURE IS IN POWER COMPANY SPACE
 B. FIXTURE IS BONDED TO SUSPENSION STRAND
 2. IF FIXTURE IS BELOW TELEPHONE CABLE AND BONDED TO STRAND INSULATING GLOVES MUST BE WORN UNLESS THE WIRES FROM THE LIGHT FIXTURE ARE 40 INCHES FROM THE POLE.

Fig. 11—Streetlight Fixture Not Requiring Use of 188A Test Set

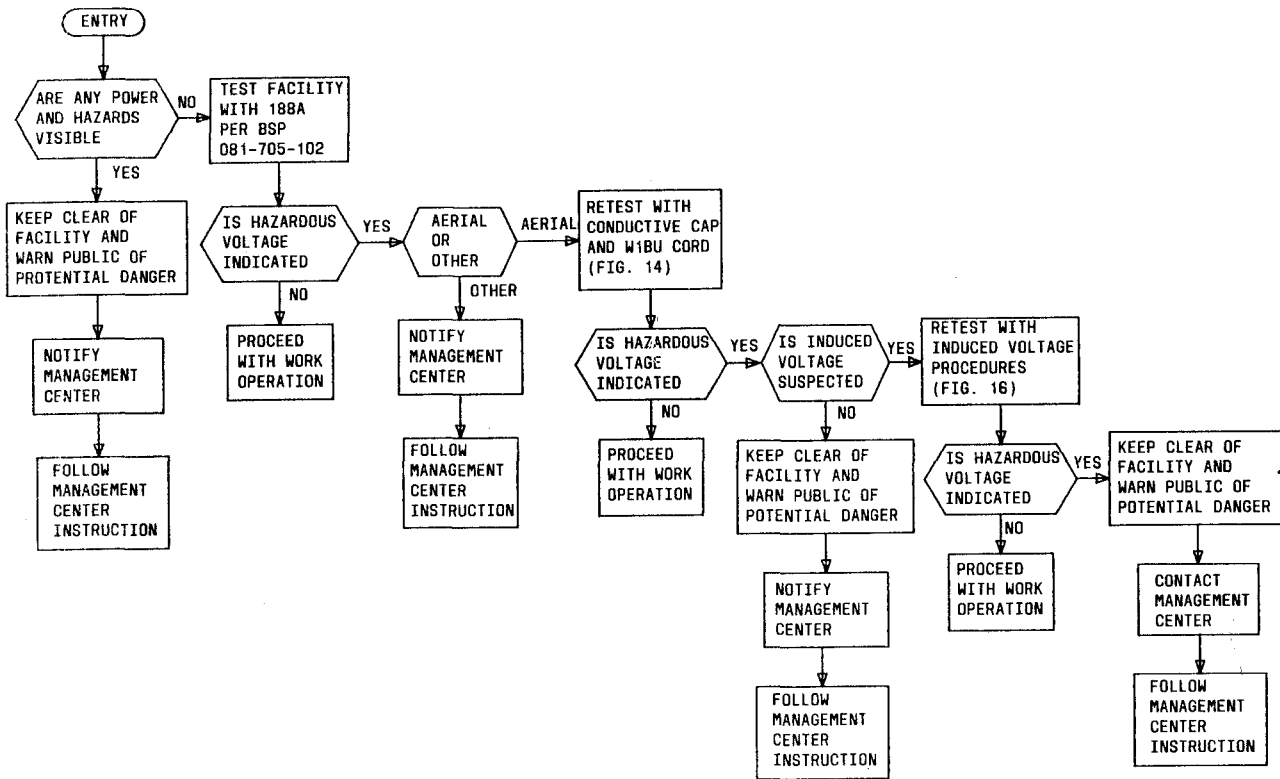

Fig. 12—Test Procedures for 188A Stoplite'

6.02 At a Pole (Vertical Ground Wire, Metallic Conduit, Or Other Hardware): When a voltage test is required in accordance with paragraph 5.02 or 5.03, proceed as follows before climbing or working on the pole.

- (1) Examine the tester for any visual defects such as deep cuts or cracks. If there are any defects, the tester must be tested with the 1188A test set prior to use.
- (2) Grasp the 188A test set handle, using the bare hand. Depress the switch and verify that the

green LED is lighted. If the green LED does not light, check batteries; replace if needed. Repeat the self-test. If the green LED still does not light, do not use.

- (3) With the switch depressed, touch both the probe tip and the "check contact", using the free hand (Fig. 13). Remove the free hand; the red LED should flash. If it does not, **do not use**.

Note: It may be necessary to wet the fingers before touching the probe tip and the "check contact".

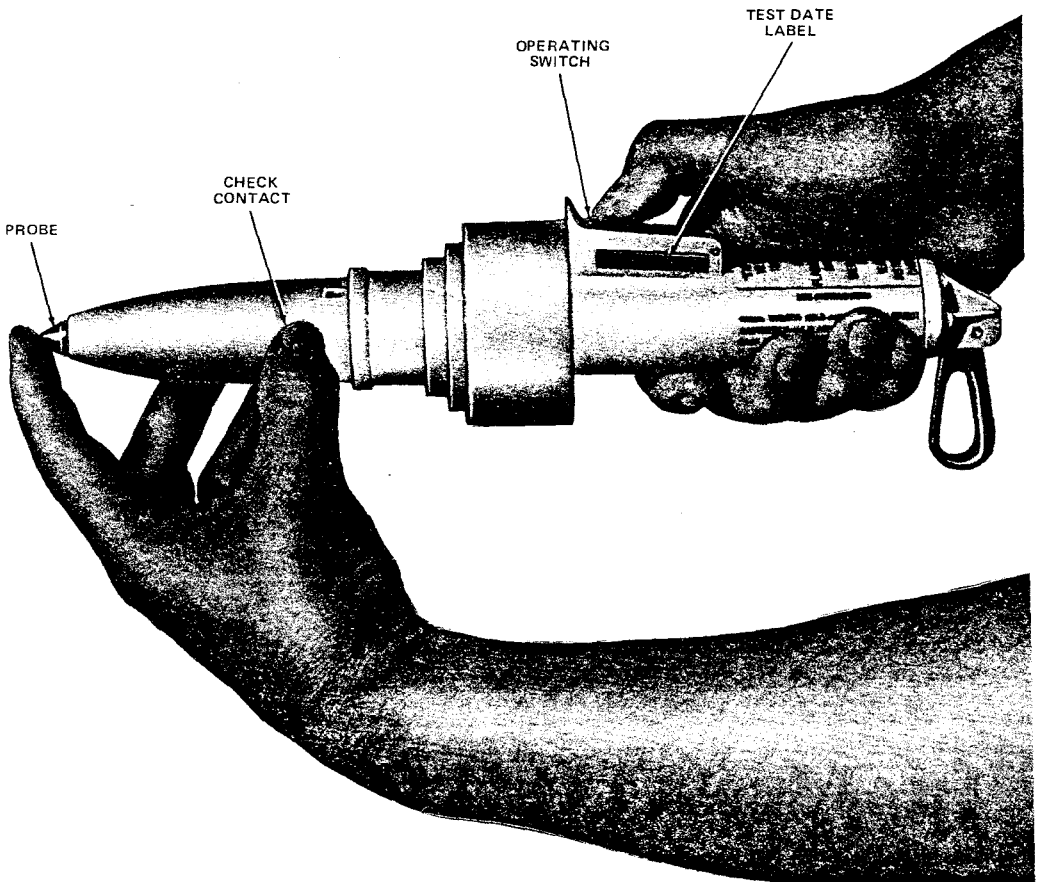

Fig. 13—Checking Test Set Before Use

(4) Once the red flashing indicator appears, it will be "locked up" as long as the switch is depressed. This allows the technician to remove the test set and read the LED display. The green LED indicates that the object is safe. The flashing red light indicates presence of a potentially hazardous foreign voltage.

(5) Protective gloves reduce test set sensitivity.

Where the voltage exceeds 20,000 volts (such as substations, power stations, etc), protective gloves are worn to test high voltage objects. If a safe condition is indicated while wearing gloves, a second test should be made with a bare hand holding the test set. This procedure will reduce the possibility of a low current surprise shock.



Hold the handle of the tester and always keep your fingers behind the flash guard rings when testing for voltage.

6.03 Do not touch the object suspected of having high voltage (damaged pedestals or objects close to high voltage lines). Depress and hold the switch of the 188A test set depressed as you approach the object. ***Should the test set begin to vibrate, hiss, or buzz, or should the red LED flash, immediately move away from the object.*** Take necessary precautions to protect the public and notify the appropriate management center (Part 10). If none of the above occurs, complete the test as outlined in paragraphs 6.04, and 6.05.

6.04 If the probe LED did not flash red during the approach to the object, press the probe end of the tester against the object to be checked for voltage. It may be necessary at times to turn the tester from side to side to break through paint, rust, or other surface finish. Ensure that a reliable contact is made.

6.05 Depress the switch and hold it down throughout the test. Still holding the switch down, remove the tester from the object being tested. A green LED is safe; a flashing red LED means danger. Take necessary precautions to protect the public and notify the appropriate management center (Part 10).

6.06 If the ground wire is broken, test the portion going up the pole unless the break exists above the telephone space. The B temporary bond can be

utilized to reestablish ground wire continuity until all work on the pole has been completed. Do not attempt to test a broken ground wire or fixture in the power company space (40 inches or more above the highest telephone attachment). Report any broken wire to your supervisor.

6.07 If a ground wire requires testing and is protected with wood molding to a height of about 8 feet, test above the molding.

6.08 If the voltage tester does not indicate a hazardous voltage by the flashing red LED in making the test described in paragraphs 6.04 and 6.05, poles carrying vertical power ground wires may be climbed without further testing. Care should be exercised to avoid simultaneous contact between power ground wires and telephone cable or guys since a small voltage may be present. This is recommended to avoid the possibility of a surprise shock which might cause a fall from the pole.

6.09 Voltage Test—Mobile Homes, Trailers, Metal Sheath Buildings, and Newly Driven Ground Rods: These locations present a potential electrical hazard and always require testing. All employees exposed to mobile homes, trailers, and metal sheath buildings should test the skin and frame, or both frames in the case of double-wide mobile homes, before starting any work operation. In some cases the technician may be wearing rubber gloves during the work operation (driving a ground rod). The final test using the 188A must be done with the bare hand holding the test set. If a voltage is detected on these objects, the property owner is to be notified so corrective action can be taken. Take necessary precautions to protect the public and notify the appropriate management center (Part 10).

6.10 Voltage Test—Cable Sheath: When the sheath is opened for the purpose of locating plant, locating faults, or making splices, it is necessary to test the sheath prior to and after opening it with the 188A test set in accordance with paragraphs 6.02 through 6.05. Before the sheath is opened a temporary bond must be placed to maintain continuity of the cable sheath.

6.11 Voltage Test—Buried Plant: If the cable to be worked on is continuous, the metal shield should be tested for foreign voltage at the nearest pedestal where tests can be made prior to removing the outer sheath. When a telephone or power pedes-

tal closure (this applies to all closures used in buried plant, whether standing alone or mounted back to back with power) has been damaged or disturbed (eg, knocked over or driven into the earth by a motor vehicle), or a trouble condition involving power is suspected, power work shall be performed first. Then proceed as follows:

- (1) Before any bodily contact is made, test, using the 188A test set.
- (2) If the test indicates the presence of power, immediately remove the test set from contact. Take necessary precautions to protect the public and notify the appropriate management center (Part 10).

6.12 It is the responsibility of the power company to clear its trouble. Telephone technicians shall not work on the telephone plant until the power company has completed repairs. After the power company has completed its work, the pedestal shall be tested with the 188A test set before any bodily contact is made.

6.13 If the tester indicates a safe condition, remove the cover of the closure and visually inspect the cable bonding and grounding connections. If they are not intact or are loose, test the connections with the test set before performing maintenance work.

6.14 If for any reason it becomes necessary to open the bonds between telephone facilities and power or across cable sheath openings, a temporary bond strap must be placed before the bond is opened. If for any reason the temporary bond cannot be placed, consult your supervisor. It may be necessary for the power company to deenergize the power briefly during repair operations to the bonds. When temporary or permanent bonds are placed or removed, rubber insulating gloves and eye protection

must be worn. Replace the bond after the fault has been located.

WARNING: Electrical continuity of all bonds, including cable sheath bonds in closures or at splice locations, must be preserved during the repair process. Until the permanent bond is installed, maintain continuity using a temporary bond strap (Section 644-200-031).

7. VOLTAGE TESTS AND SAFEGUARD ALOFT, UNDER, OR NEAR POWER TRANSMISSION LINES

7.01 When making voltage tests aloft from an insulated facility such as a pole or aerial lift vehicle, a hazardous voltage may be indicated due to induced voltage when none actually exists. In these cases, a ground reference must be provided for the 188A test set. Use flow chart (Fig. 14) as a guide to provide a ground reference.

7.02 Streetlight fixtures, pole-to-pole guys extending near power company facilities, and power company hardware in the telephone company workspace must be tested for potentially hazardous voltage as follows:

- (1) Put on protective equipment including a hard hat, eye protection, etc, and climb to a convenient height to make the voltage test. Do not contact the suspected hardware, light fixture, or its wiring.
- (2) Test the object in accordance with paragraphs 6.01 through 6.05.
- (3) If the green LED remains lighted after depressing the switch and touching the probe tip to the object being tested, you may proceed with your work after placing a temporary bond as specified in paragraph 7.03.
- (4) If the red LED is flashing, it may be caused by the electrostatic voltage induced on the body of the user from the power transmission line. In such cases, the procedures described in Part 9 must be followed.

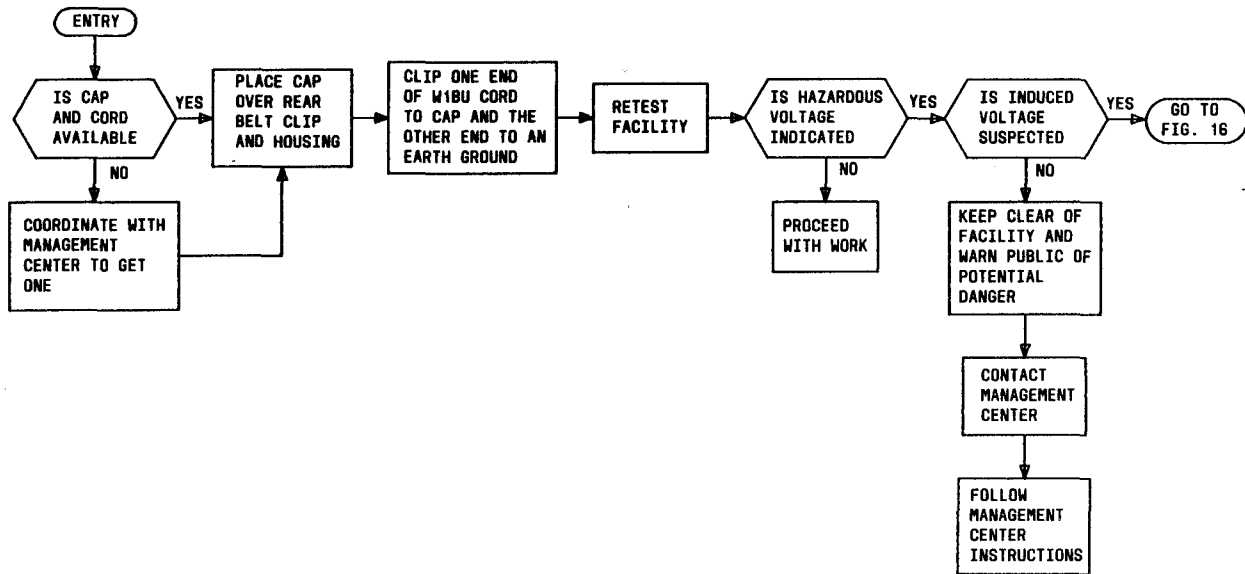
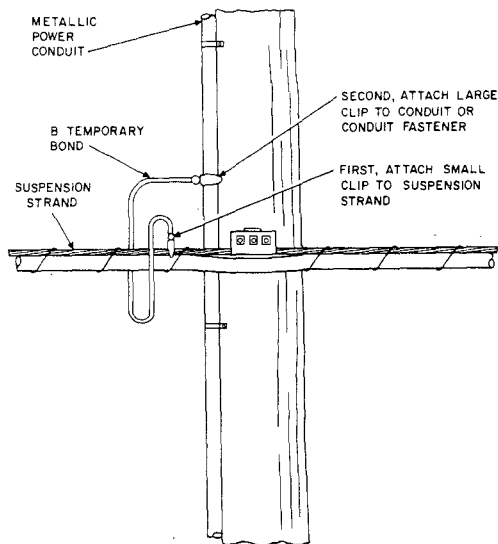

Fig. 14—Ground Reference Test for 188A Test Set

7.03 Use of the B Temporary Bond: The B temporary bond is used to temporarily ground a fixture, conduit, or bare vertical ground wire (Fig. 15) while working aloft. Should a fault develop, the B temporary bond will provide a direct path to ground for the foreign potential. The insulation on the bond may overheat and smoke which should alert the technicians to descend the pole. Using rubber insulating gloves, attach the bond in the following manner:

- (1) Attach the small clip of the B temporary bond to the cable suspension strand in such a manner that it will not be in the way of work operations
- (2) Attach the large clip of the bond wire to the fixture, conduit, or bare vertical ground wire.



NOTE:
WEAR INSULATING GLOVES

Fig. 15—B Temporary Bond Attachment to Metallic Power Conduit

Do not bond to a support bracket of multiple line wire or the strand of isolated cable. **Never attach to any streetlight wire or terminals to which they are attached or to any fixture which causes the red LED on the 18EA test set to flash.**

7.04 The rubber insulating gloves may be removed only after the temporary bond is in place, and then only if other protection requirements permit. Leave the B temporary bond in place until all work operations have been completed at this pole for the day. If the bond starts smoking, put on insulating gloves and descend the pole immediately. Avoid contact with the bond, the fixture, or its wiring. Take necessary precautions to protect the public and notify the appropriate management center (Part 10).

7.05 Upon completion of work operations on a pole, remove the B temporary bond as follows:

- (1) Put on rubber insulating gloves.
- (2) Remove the clip from the fixture, metallic conduit, or bare vertical ground wire. If a spark is detected when removing the bond, descend the pole immediately. Take necessary precautions to protect the public and notify the appropriate management center (Part 10).
- (3) Remove the other clip from the strand.

8. DC VOLTAGE TESTING

8.01 Direct current voltage hazards may be present in certain locations, such as near electric railway, subway, or trolley car lines or associated equipment.

8.02 To test in these locations perform the procedures in Parts 5, 6, and 7. If no ac hazards exist, proceed to paragraph 8.03.

8.03 Test the B temporary bond to be used as a ground cord. Connect the small end clip to the 188A probe tip. Press and hold the 188A trigger switch. Touch the large B bond clip end to the check contact. The red indicator should flash. **Do not use a B bond for testing if it does not pass this test.**

8.04 Connect the B bond large end clip to a strand, ground wire, or other conductor known to be earth grounded and the small clip to the 188A GND contact.

8.05 Press the probe end of the 188A against the object to be tested for voltage. Ensure that a reliable contact is made. Press the trigger and hold it down. Remove the probe from the object and observe the LED indicators. A green LED is safe; flashing red means danger. **If the red LED is flashing, do not touch the energized object.** Take necessary precautions to protect the public and notify the appropriate management center (Part 10).

9. INDUCED VOLTAGE TESTING

9.01 In limited situations, a potentially hazardous voltage will be indicated by the 188A test set when none actually exists. These erroneous indications occur because of induced voltages from the power facilities to the telephone plant. There is no appreciable current flow connected with these induced voltages and they present no danger to the technician.

9.02 The following are some of the facilities most often affected by induced voltages.

- Nongrounded metallic objects on poles (pole steps, lags, signs, etc)
- Nonmetallic shields such as plastic U-guards
- Jointly used poles.

9.03 DANGER: If there are obvious contacts to a power facility, an electrical hazard exists. Foreign voltage reporting procedures outlined in Part 10 should be followed. If the technician suspects that the cause of a hazardous voltage indication is an induced voltage, the following procedure should be followed. Figure 16 is a flow-chart for making induced voltage tests.

Note: Only when an induced voltage situation is suspected, should this method be implemented. Obvious power hazards should not be tested with this procedure.

- (1) Attach an additional WIBU cord to the probe tip of the 188A test set.
- (2) Attach the other end of the WIBU cord to the positive lead of a voltmeter.
- (3) Attach the common lead of the voltmeter to a separate earthground other than the one used with conductive cap and WIBU cord. Ground the 188A test set if appropriate.
- (4) Turn the voltmeter on.
- (5) Place the voltmeter in such a position as to be read without being in physical contact with the voltmeter. This may require a second person on the job site.
- (6) **DANGER: To avoid the possibility of electrical shock, do not make contact with the voltmeter or cords while performing this test.** The technician should retest the facility with the 188A test set connected to the voltmeter, using the conductive cap and WIBU cord.
- (7) If a hazardous voltage is still indicated, foreign voltage reporting procedures should be followed (Part 10).
- (8) If the 188A test equipment indicates that the facility being tested is safe (**green LED lighted and the voltmeter indicates less than 50 volts**), the facility is safe.
- (9) If the 188A test set indicates that the facility being tested is safe (**green LED lighted and the voltmeter indicates greater than 50 volts**), the facility is not safe. Hazardous voltage exists and foreign voltage reporting procedures should be followed (Part 10).

Note: A 188A test set that indicates a safe condition (green LED lighted) with a voltmeter indication of greater than 50 volts is suspected of being defective. A second test should be made using a different 188A test set.

10. FOREIGN VOLTAGE REPORTING PROCEDURES

10.01 When a technician encounters a potentially hazardous foreign power condition, the appropriate management center must be notified.

10.02 The responsible management center employee must respond as follows:

- (1) Insure that the reporting technician is a safe distance from the potentially hazardous voltage.
- (2) Insure that the public is protected from the potentially hazardous voltage.
- (3) Determine the exact location of the potential hazard.
- (4) Instruct the technician to remain on the site until relieved by a supervisor.
- (5) Dispatch a supervisor equipped with a 188A test set with a conductive cap, two WIBU cords, and an ac voltmeter.
- (6) Identify the affected plant, inform concerned parties that a foreign power hazard may exist in the area, and warn all affected personnel to remain clear of the potential hazard.

Note: If there are other technicians involved with the potentially hazardous plant, these persons must be contacted and directed to stay clear of the affected area until the potential hazard has been cleared.

- (7) If the supervisor verifies that a hazard actually exists (paragraph 10.03), the responsible management center employee will contact the appropriate power company and inform them that a power hazard has been identified.
- (8) The management center is responsible for the overall coordination of the operation until the hazard is cleared.
- (9) Once the hazard is cleared, the management center will notify all parties concerned that the problem has been resolved.

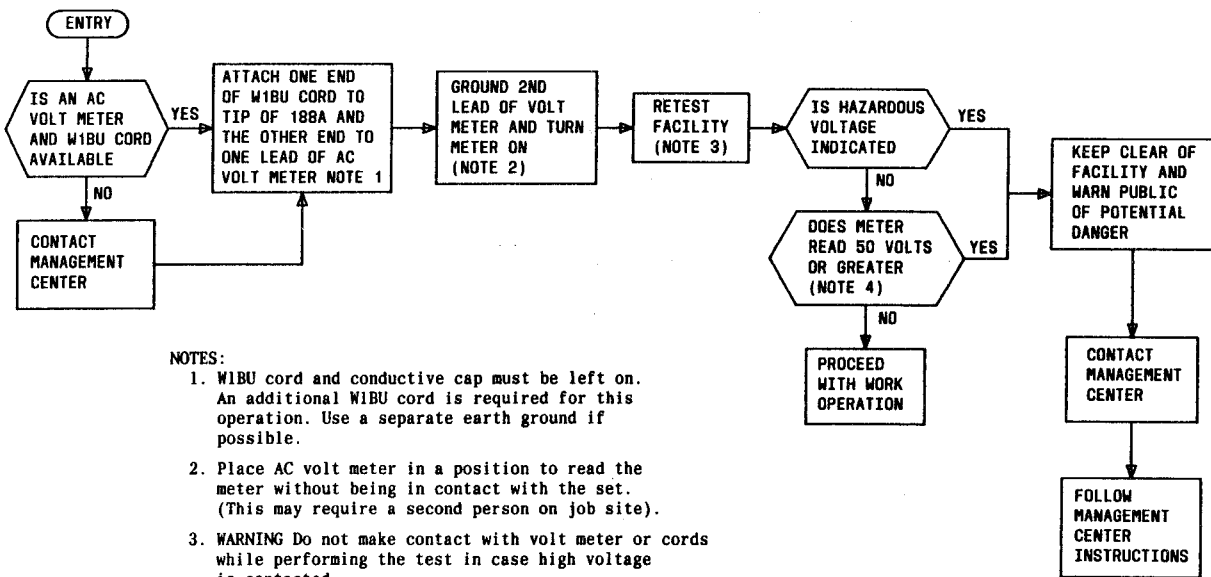

NOTES:

1. WIBU cord and conductive cap must be left on. An additional WIBU cord is required for this operation. Use a separate earth ground if possible.
2. Place AC volt meter in a position to read the meter without being in contact with the set. (This may require a second person on job site).
3. WARNING Do not make contact with volt meter or cords while performing the test in case high voltage is contacted.
4. A 188A that indicates a safe condition (Green Light) with a meter indication of over 50 volts is suspect of being defective.

Fig. 16—Induced Voltage Test

10.03 The supervisor dispatched to the site will:

- (1) Determine that all appropriate tests were made.
- (2) Verify with his test equipment (188A test set with conductive cap, WIBU cords, and voltmeter) that a potentially hazardous voltage does or does not exist.
- (3) Report to the management center and verify that a hazard does or does not exist.
- (4) Meet the power company on site and explain the tests that were made.

10.04 When the power company has corrected the problem, the supervisor must retest the facility and be assured that no foreign power exists before allowing the technician to resume work operations. After the problem has been corrected, the supervisor must notify the management center that the hazard has been cleared.

10.05 If the supervisor does not get an indication of a potentially hazardous voltage with his test equipment, the supervisor must observe the technician performing the various tests to insure that proper procedures are being followed.

11. CARE AND STORAGE

11.01 The 188A test set must be handled and stored with care. It can be stored in two ways. The 188A may be left on the work belt if the belt is stored in such a way as to ensure that the 188A is not subject to possible pressures from materials or tools. It can be stored in the AT-8924C storage bag with the B temporary bond wire and W1BU cord.

11.02 Remove any dampness or dirt with a clean cloth before using or storing. Keep the instrument free of grease or oil to prevent deteriora-

tion of insulation. Use a mild soap solution to clean. Do not use solvents on the test set.

11.03 Avoid exposing or storing the instrument in a hot area such as may be encountered near radiators, etc.

11.04 The instrument is to be carried down or lowered from poles, not dropped, as the impact may damage the internal wiring.

11.05 When replacing batteries (Fig. 17), always use a 9V alkaline such as Eveready* 522. Batteries of other manufacture may be physically larger and could damage the test set if used. As the battery becomes weak the green LED will become dim or will not light. When this occurs, the battery should be replaced. To prevent damage to internal components, exercise care when replacing the battery.

11.06 Four repair kits are available for the 188A test set. These repair kits are designed to allow field replacement of missing or broken belt clips, screw and ground contacts, rear assemblies, and front housing assemblies. Each kit contains the necessary instructions for replacing the defective or missing component. When any component of the test set is replaced, it will be necessary to test the integrity of the test set, using the 1188A test set. Ordering information for field repair kits is as follows:

COMCODE	CODE	FOR REPLACING
103381554	D181127	Belt Clip
103707196	D181146	Screw and Contact
103710331	D181147	Rear Assembly
103710349	D181148	Front Housing Assembly

12. ORDERING

12.01 Orders for the 188A test set shall be worded as follows: (quantity) Set, Test, 188A COMCODE 103-082-669.

* Registered Trademark of Union Carbide Corporation

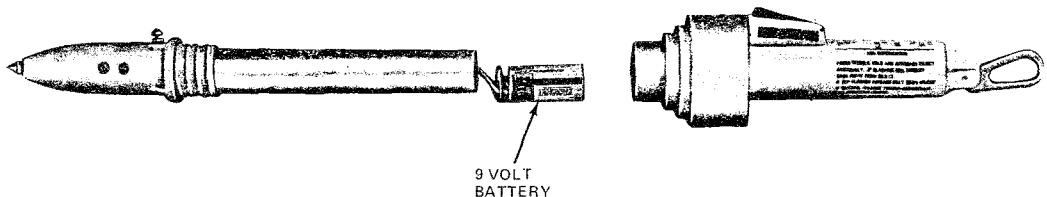

Fig. 17—Battery Location