

## CHAPTER 10

### 4A TOLL SWITCHING SYSTEM

#### 10.1 INTRODUCTION

The growth of toll traffic within the Bell System during the past thirty years has been amazing. In an attempt to keep abreast of this growth, provide new and better facilities, and at the same time obtain maximum use of existing facilities, the No. 4 Toll Switching System was designed.

The No. 4 Toll Switching System, of which the 4A is the latest model, is a four wire system, using one pair of wires for transmitting and one pair for receiving. All switching is done mechanically. The No. 4A Toll Switching System was designed to serve as a Control Switching Point (CSP) in the switching of intertoll traffic on a nationwide basis. However, until the ultimate goal in FACD, or Foreign Area Customer Dialing is attained, operator assistance will be necessary at some points.

The No. 4A Toll Switching System is capable of handling switching between points using either a 3-digit central office code, or a 6-digit code including both the Numbering Plan Area (NPA) and the local area office codes. It has provisions for translating the full 6-digit code for selection of the correct route where more than one route exists to another NPA. It has features capable of varying the number of digits sent to the distant office and in some cases substituting other code digits when passing all or part of the full 6-digit code to a distant point. Another feature is the alternate routing of traffic when the first choice high usage group is busy. Under certain circumstances as many as seven different routes from one CSP can be tested in a search for an idle path.

From the old method of calling "Long Distance" to leave the name of the called party and waiting from 15 minutes to several hours to get the connection to the present method of dialing directly to the called party covers many years of research and development in the field of telephone system communications.

10.2 TOLL SWITCHING SYSTEM

The 4A Toll Switching System is a part of the Nationwide Toll Dialing Plan for operator and customer dialing of toll calls. The plan provides for long-distance operators or customers to dial or key the information for routing a call. The switching equipment then automatically completes the call.

Figure 10-1 shows the relationship of the 4A Toll Switching System to the Toll Switching Plan.

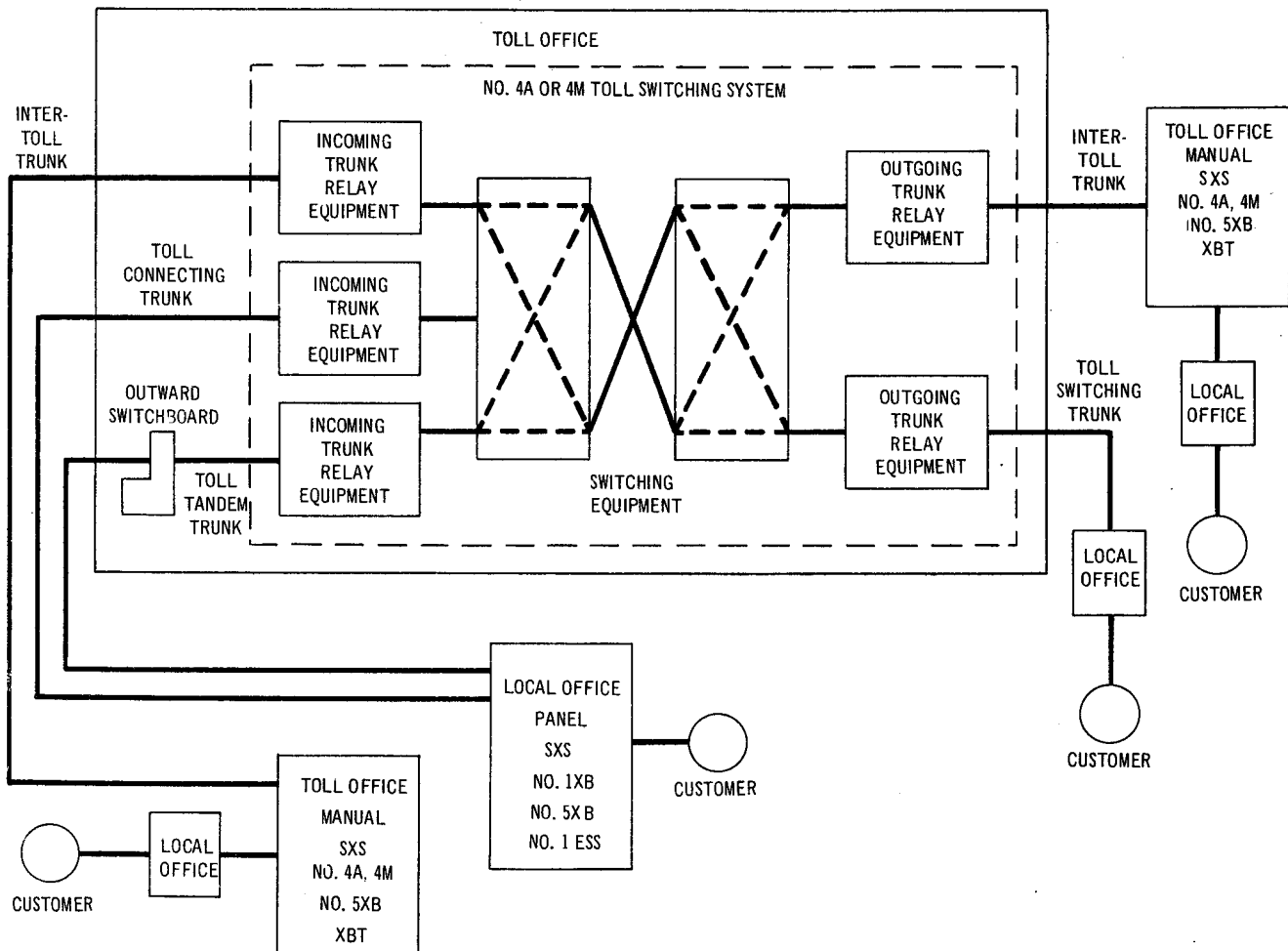

Figure 10-1 - Relationship of 4A Toll Switching Systems to General Toll Switching Plan

A. SWITCHING PLAN

Crossbar switches arranged on incoming and outgoing link frames, and common control equipment provides 4-wire paths for establishing connections mechanically between intertoll trunks, tandem and intertoll trunks, and intertoll and toll switching or miscellaneous terminating trunks. Common control equipment consisting of markers, senders, decoders, card translators, link controllers, and trunk block connectors will set up the switching paths and receive and send, as necessary, the pulsing and signaling information required for completion of a call. The relationship of the link frames and the common control equipment is shown in Figure 10-2.

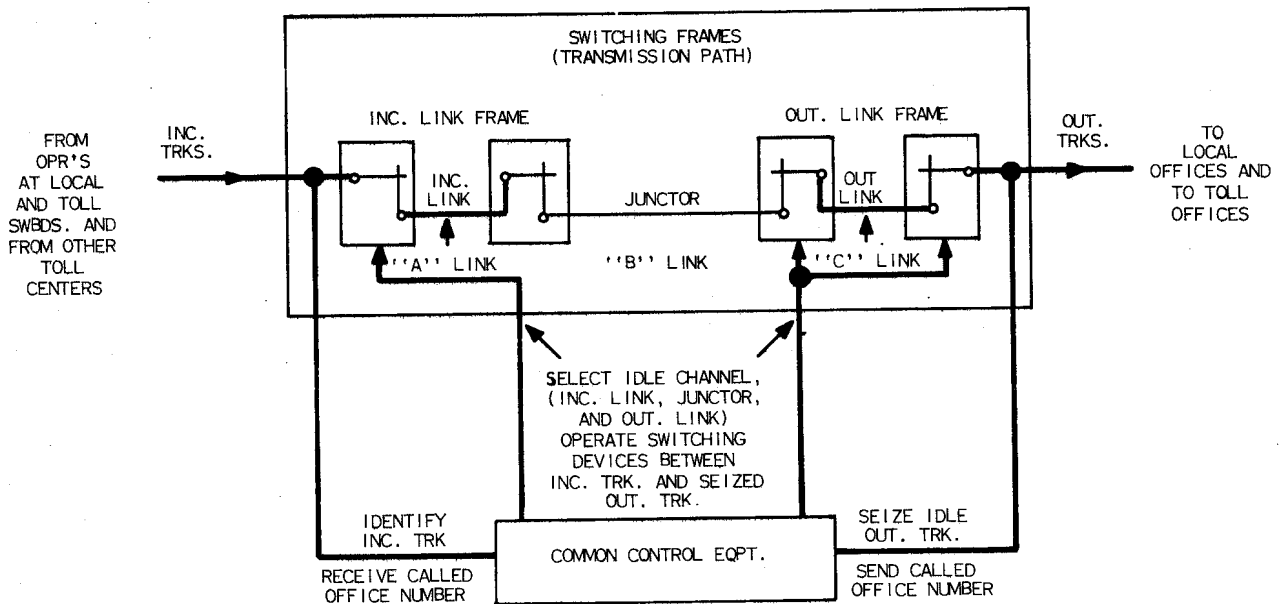

Figure 10-2 - Relationship Between Common Control Equipment and Switching Frames

Common control means that the switches in the talking connections are set up by certain equipment units which are common to many of the switching frames in the office. A common control system has the ability to store and reuse digits. Other common control circuits associated with the CAMA portion of the 4A system are: transverters, billing indexers, recorders, position link controllers, and master timers which are not discussed in this section.

The marker is one of the major control units of the common control equipment. One of its functions is to make sure that there is an idle outgoing trunk available before attempting to set up a talking connection.

The common control equipment is used on each call only long enough to set up a talking connection, after which it releases and is ready to serve another call. In this manner a few units of complicated equipment are used for short periods of time to set up the switches for a proportionately large number of calls.

#### 1. 4-Wire Talking Path

The 4A system is a 4-wire transmission system. This means that two voice paths per trunk are provided through the switches - one for each direction of transmission.

The 4-wire transmission system eliminates a need to convert 2-wire trunks to 4-wire and back to 2-wire for voice repeaters and also eliminates the undesirable transmission effects caused by these conversions.

A conversion from 4-wires is still required, however, when connecting to a 2-wire office. This would be at the originating and terminating ends, so that the call can be switched through local automatic switching equipment or via a switchboard to the customer.

The 4A system starts with the trunk relay equipment on the incoming intertoll or incoming toll connecting trunks, and ends with the trunk relay equipment on the outgoing intertoll or toll switching trunk.

Calls arriving at the 4A toll office may have been originated by an operator or customer. As there is no incoming class indication used by

these systems, the equipment can not differentiate between operator and customer calls. Incoming calls with a few exceptions are routed from the digital information alone.

After the number has been registered, the No. 4A system automatically takes over. A route that can complete to the terminating local office is selected, routing information is transmitted to the distant toll office and the call is then completed.

## 2. Nationwide Dialing Requirements

Nationwide dialing requires that calls be switched on a destination basis rather than on a trunk route basis. To route calls on a destination basis requires in some cases that the 4A system be able to examine and use (translate) six ditits.

Another requirement of nationwide dialing is automatic alternate routing. With manual toll switching, if a toll operator finds all the trunks busy on a given route to a distant city, she can select other alternate routes over which the call can be completed. 4A systems have the ability to automatically scan rapidly and select a route from several alternates in its attempts to establish a connection. The 4A system automatically checks the preferred route and as many as five alternate routes in rapid succession, although the actual use of five subsequent choices is not typical.

To complete some calls, it is necessary to delete or to change the area or national office code digits, dialed or keyed by the operator or customer before the number is pulsed to the next office. This is done by the use of the variable spilling and code conversion features. Either one or both of these features may be used on a given toll call. With variable spilling, all the code digits can be spilled forward or some of them can be skipped and the remaining digits spilled forward. Three or six digits may be skipped. The code conversion feature makes it possible to change one or as many as three consecutive digits to different numerals before they are spilled forward. In addition, one, two, or three digits can be prefixed as required before spilling.

B. NO. 4A TOLL SWITCHING EQUIPMENT

The equipment used in the No. 4A Toll Switching System can be divided into the following groups:

Switching Equipment  
Sender Link Frames  
Common Control Equipment  
Trunk and Traffic Equipment  
Maintenance Center Equipment

Two arrangements of equipment are provided for the No. 4A System, one with a single train for smaller offices where the number of incoming or outgoing frames will not exceed forty, and the other with two trains each having this capacity. The single train arrangement handles both intertoll and toll completing traffic with a maximum of ten markers and ten decoders. Such an office is called a "Combined Train Office" and is shown in Figure 10-3. The two train offices operate with a maximum of ten markers for each train and twenty-four common decoders and are called "Separate Train Offices - Combined Operation" to distinguish them from other two train offices used in the earlier No. 4 type toll switching systems. Figure 10-4 illustrates a call through a separate train office. In the 4A two train arrangement each train handles both intertoll and toll completing traffic with multiple appearances of all incoming trunks on the incoming link frames of both trains. The trains involve several arrangements which differ essentially in junctor distribution.

1. Incoming Links

An incoming link (A link) is a five wire interconnection between the primary and secondary switches of the incoming link frame. The incoming link frame is the first frame on which the talking paths terminate in a 4A Toll Switching Office. Ten 200 - point, 5 wire crossbar switches are mounted on a "Primary Bay" of each incoming link frame. 200 - point, 5 wire crossbar switches having split horizontals are mounted on a "Secondary Bay." One hundred incoming trunks, ten per switch, are connected to the horizontals of the primary switches, two hundred junctors, twenty per switch, are connected to the verticals of the secondary switches.

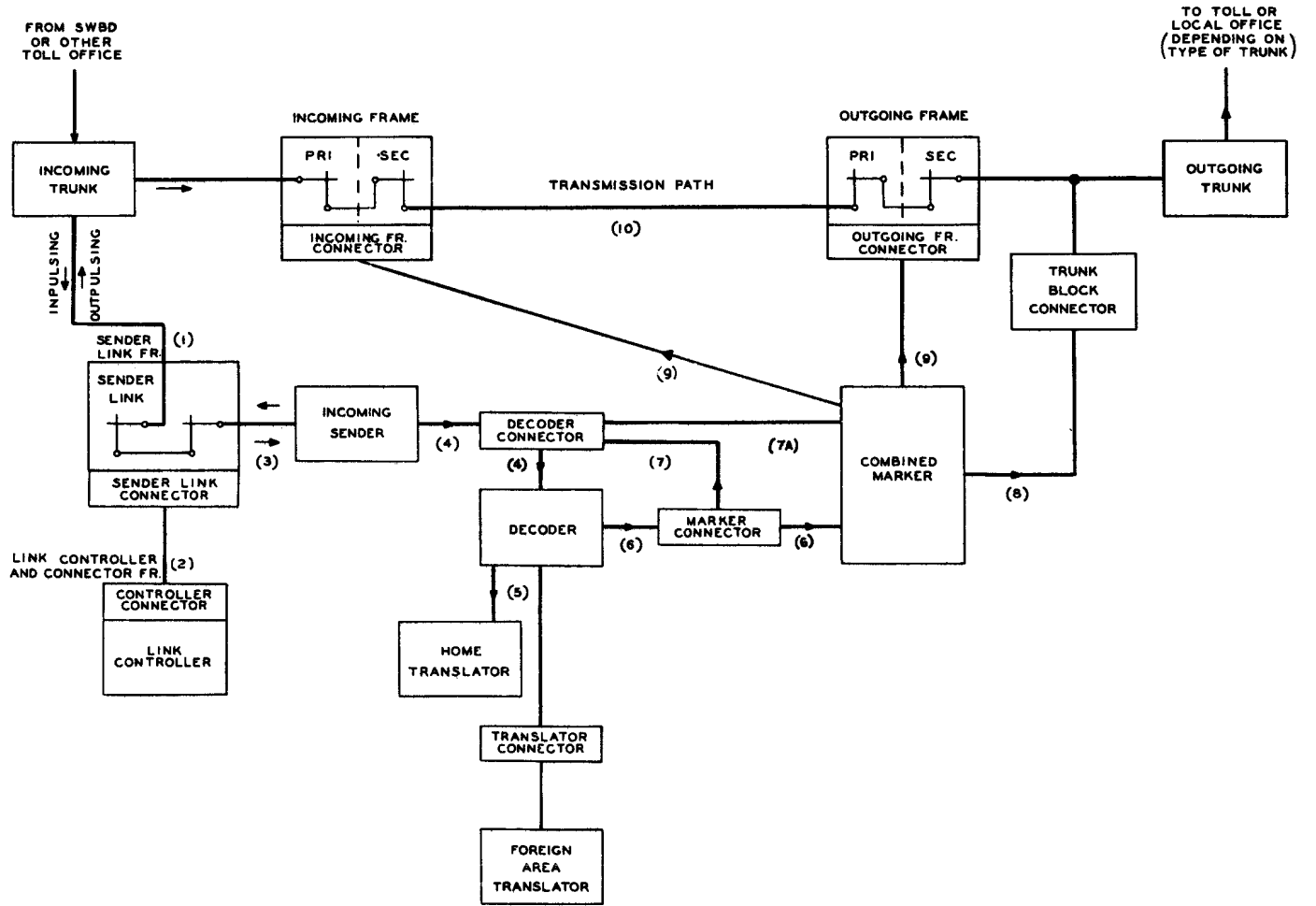

Figure 10-3 - Call Through a Combined Train Office





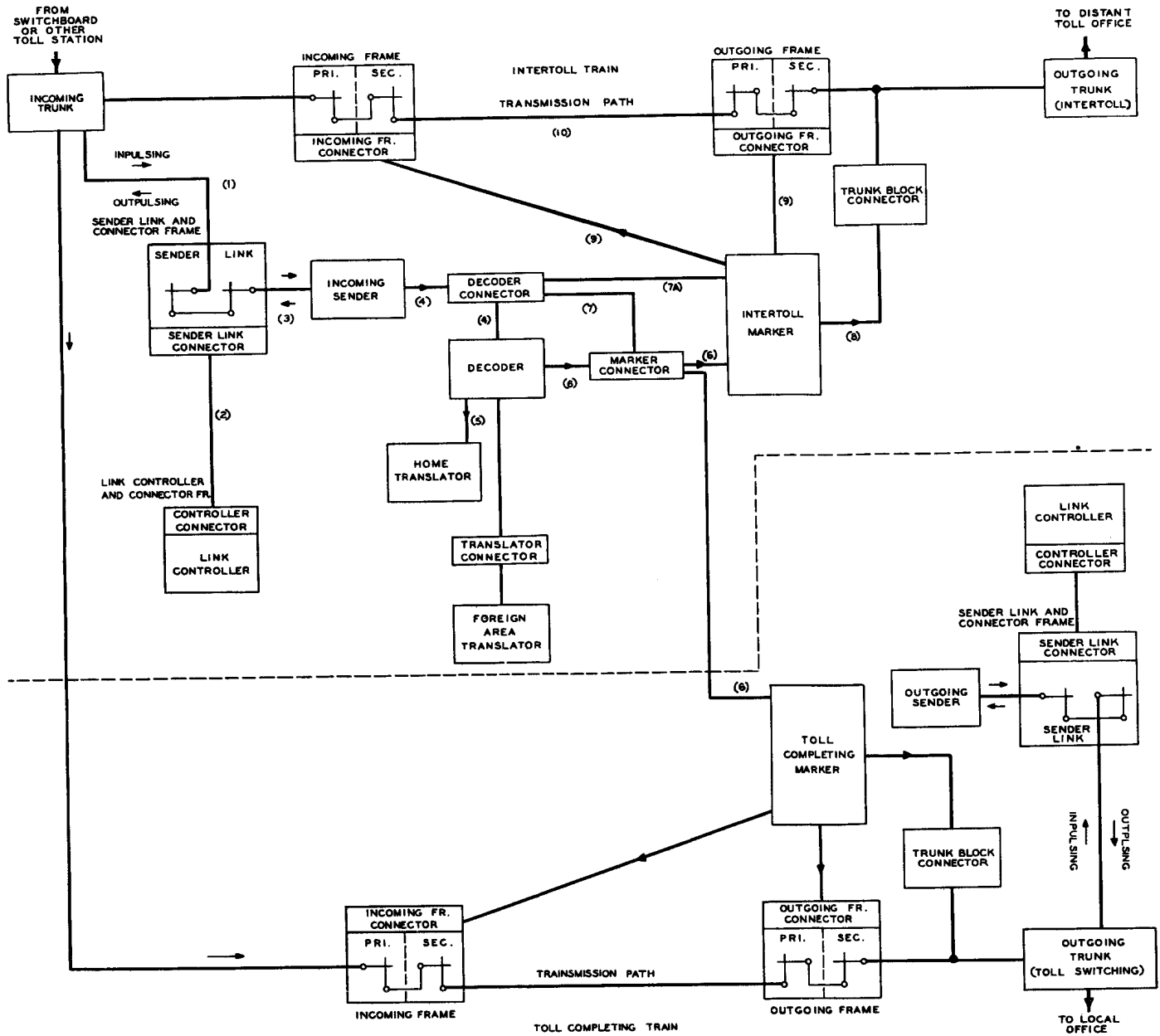

Figure 10-4 - Call Through a Separate Train Office



Two hundred incoming or "A" lines are distributed over the secondary switches in accordance with a fixed pattern, as shown in Figure 10-5. This pattern is such that the twenty links from the verticals of any primary switch are evenly distributed over the ten secondary switches, two per switch. The left verticals of the primary switches always terminate on the left horizontals of the secondary switches and the right verticals of the primary switches always terminate on the right horizontals of the secondary switches. Thus, any of 100 incoming trunks has access to any of the 200 junctors.

Since an incoming link appears on a vertical of a primary half-switch and on a horizontal of a secondary half-switch, and "A" link may be traced in accordance with the following rule: The primary vertical number is the same as the secondary switch number on which it appears, and the primary switch number is the same as the secondary horizontal number. This arrangement of incoming links is known as a vertical-to-horizontal spread and obviates the necessity of providing designation strips for the tracing of incoming links.

## 2. Junctors

The junctors interconnect the verticals of the secondary switches of the incoming link frames and the verticals of the primary switches of the outgoing link frames. These junctors, which are 5 wire links, are also called "B" links. The respective crossbar switches each have 20 verticals, thereby providing termination for twenty junctors, or 200 junctors per frame.

Since any incoming trunk must have access to any outgoing trunk, the junctors are grouped and interlaced as shown in Figure 10-6. It will be seen that, with this arrangement, the 200 junctors on one incoming link frame must be divided into as many groups as there are outgoing frames. Each group must carry all of the traffic load from the trunks on one incoming link frame to the trunks on one outgoing link frame. Also, it should be observed that the number of junctors on an incoming link frame is equal to the number which appears on the outgoing link frame.

CH. 10 - 4A TOLL SWITCHING SYSTEM

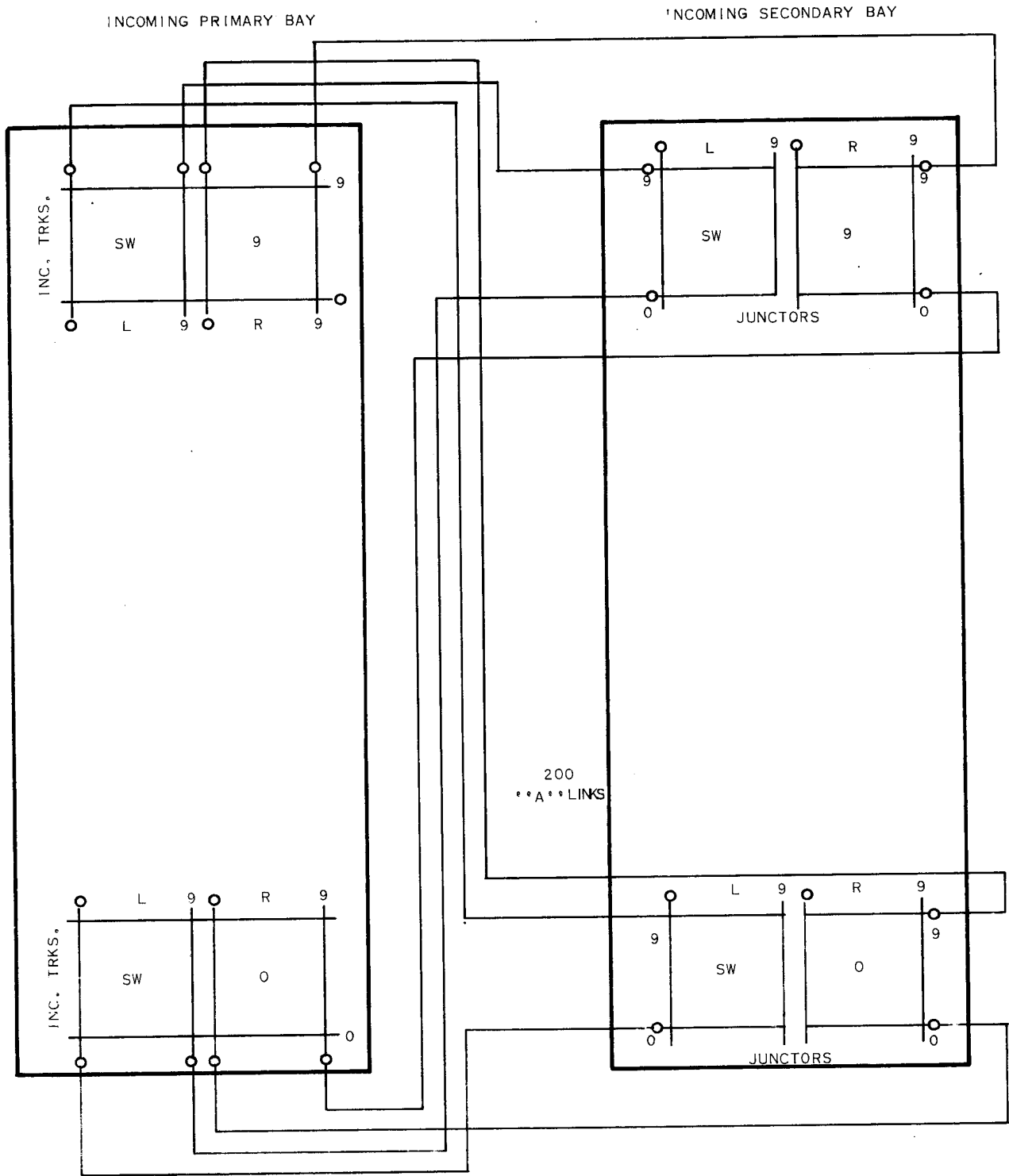

Figure 10-5 - Incoming Link Spread

As the number of incoming and outgoing link frames increases, the possible number of junctors between any two frames must decrease. That is, the size of each junctor group decreases due to the fact the fixed number of junctors on an incoming link frame is divided into as many groups as it has frames to reach. Example: If there are four incoming link frames and four outgoing link frames, then the 200 junctors from any incoming link frame must be divided into four groups consisting of 50 junctors per group; now if the office was increased to eight incoming link frames and eight outgoing link frames, then the 200 junctors from any incoming link frame must be divided into eight groups consisting of 25 junctors per frame.

Design provides that the number of junctors in a group must not be less than ten. This number is reached when the number of incoming link frames in an office reaches 20. For more than 20 frames an arrangement known as "pairing of frames" is employed. The incoming link frame capacity may be increased to 400 junctors by adding a secondary extension bay of ten 200 point 5 wire switches. These additional 200 verticals, thus obtained, together with the 200 verticals of the regular bay of secondary switches, provides terminations for 400 junctors. There are only 200 "A" links serving these 400 junctors, and in order to load them to their full capacity, the same 400 junctors multiple to like numbered verticals on secondary switches of another incoming link frame. The two frames which share the use of these 400 junctors are called an incoming group. The distribution of these 400 junctors of an incoming link frame group is shown in Figure 10-7.

### 3. Outgoing Link Frame

The outgoing link, or "C" link, is a five wire interconnection between the primary and secondary switches of the outgoing link frames. The outgoing link frame consists of ten 200 point 5 wire switches with split horizontals on the primary bay and ten 200 point 5 wire switches on the secondary bay. There are 200 junctors, with 20 junctors, appearing on the twenty verticals of each primary switch, ten on the left half and ten on the right half. The 200 "C" links are

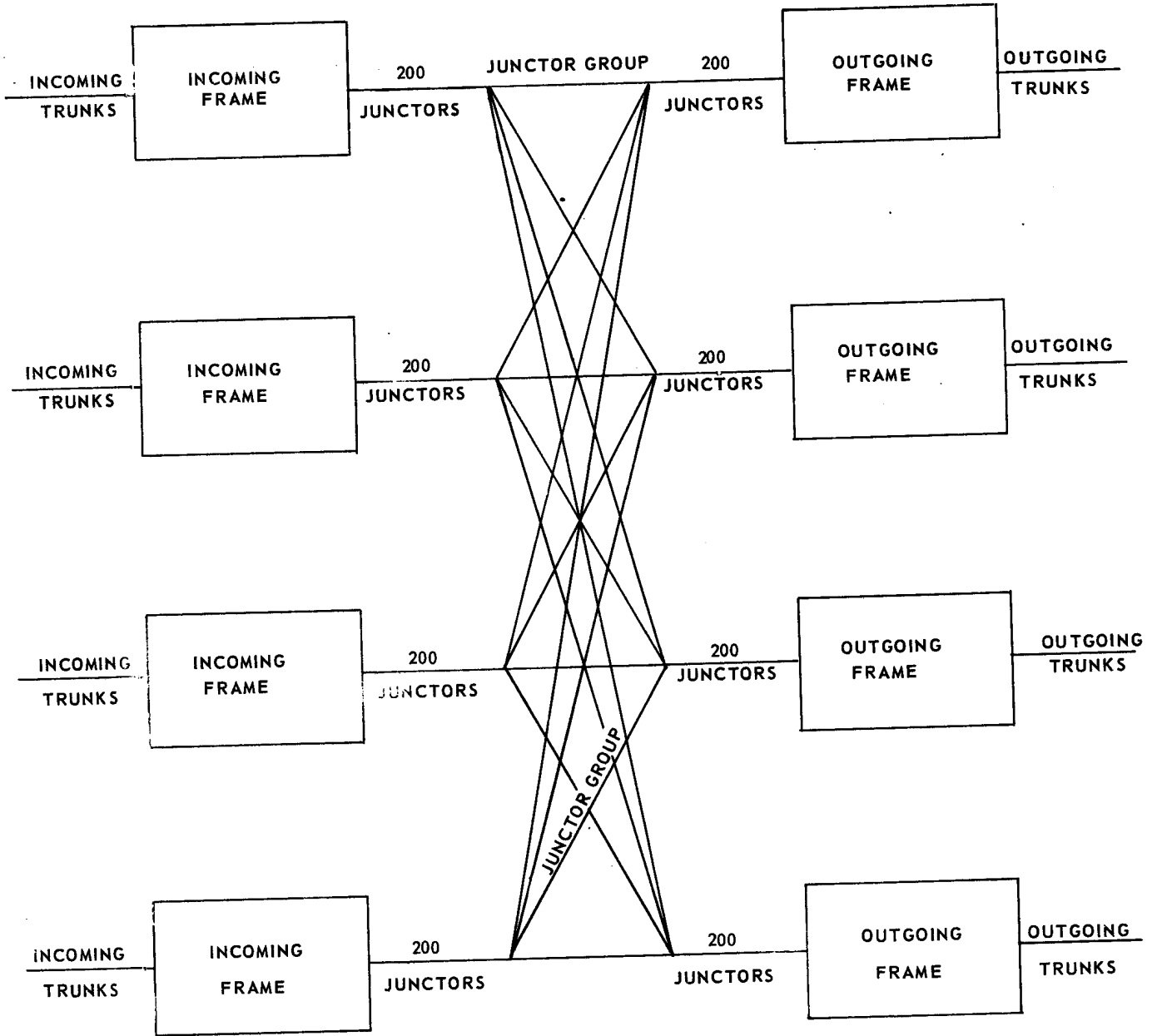

Figure 10-6 - Junctor Spread

CH. 10 - 4A TOLL SWITCHING SYSTEM

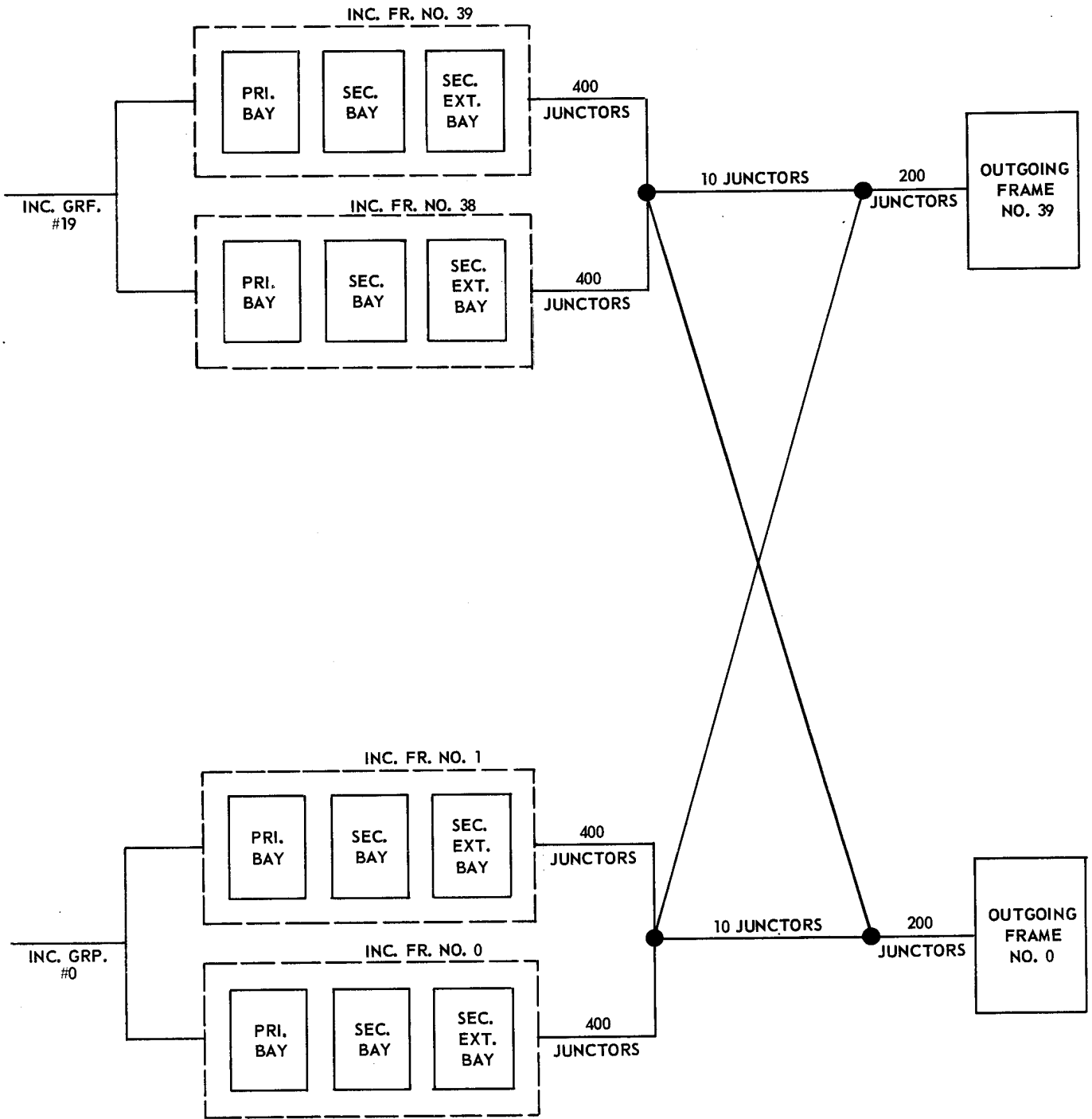

Figure 10-7 - Pairing of Incoming Frames

distributed over the secondary switches in a fixed pattern, as shown in Figure 10-8. This pattern is such that the 20 links from the horizontals of any primary switch are evenly distributed over the verticals of all ten secondary switches, two per switch.

One hundred outgoing trunks, ten per switch, appear on the horizontals of the secondary switches. Thus, any one of the 200 junctors has access to any one of the hundred outgoing trunks.

Since an outgoing link appears on a horizontal of a primary half-switch and on a vertical of a secondary half-switch, any "C" link may be traced in accordance with the following rule: The primary horizontal number will be the same as the secondary switch number on which it appears, and the primary switch number is the same as the vertical number on the secondary switch. This method of link distribution is known as a horizontal-to-vertical link spread. In addition, a horizontal on the left half of a primary switch is always connected to a vertical on the left half of a secondary switch, and a horizontal on the right half of a primary switch is always connected to a vertical on the right half of a secondary switch.

The outgoing link frames provide a means for terminating the talking paths of all outgoing trunks in a 4A office, whether to outgoing inter-toll trunks or to toll completing trunks. Through the office control equipment it can be assured that every outgoing trunk in the office is accessible to every incoming trunk.

#### 4. Channels

A channel is a combination of an incoming or "A" link, a junctor or "B" link, and an outgoing or "C" link. This combination of links forms a chain, by means of crosspoint closures, that will connect an incoming trunk with an outgoing trunk. Each group of ten or more junctors connecting an incoming frame with an outgoing frame is spread at both ends over the ten junctor switches, the left and right halves and switch numbers being the same at both ends for each junctor. Considering a particular incoming trunk on an



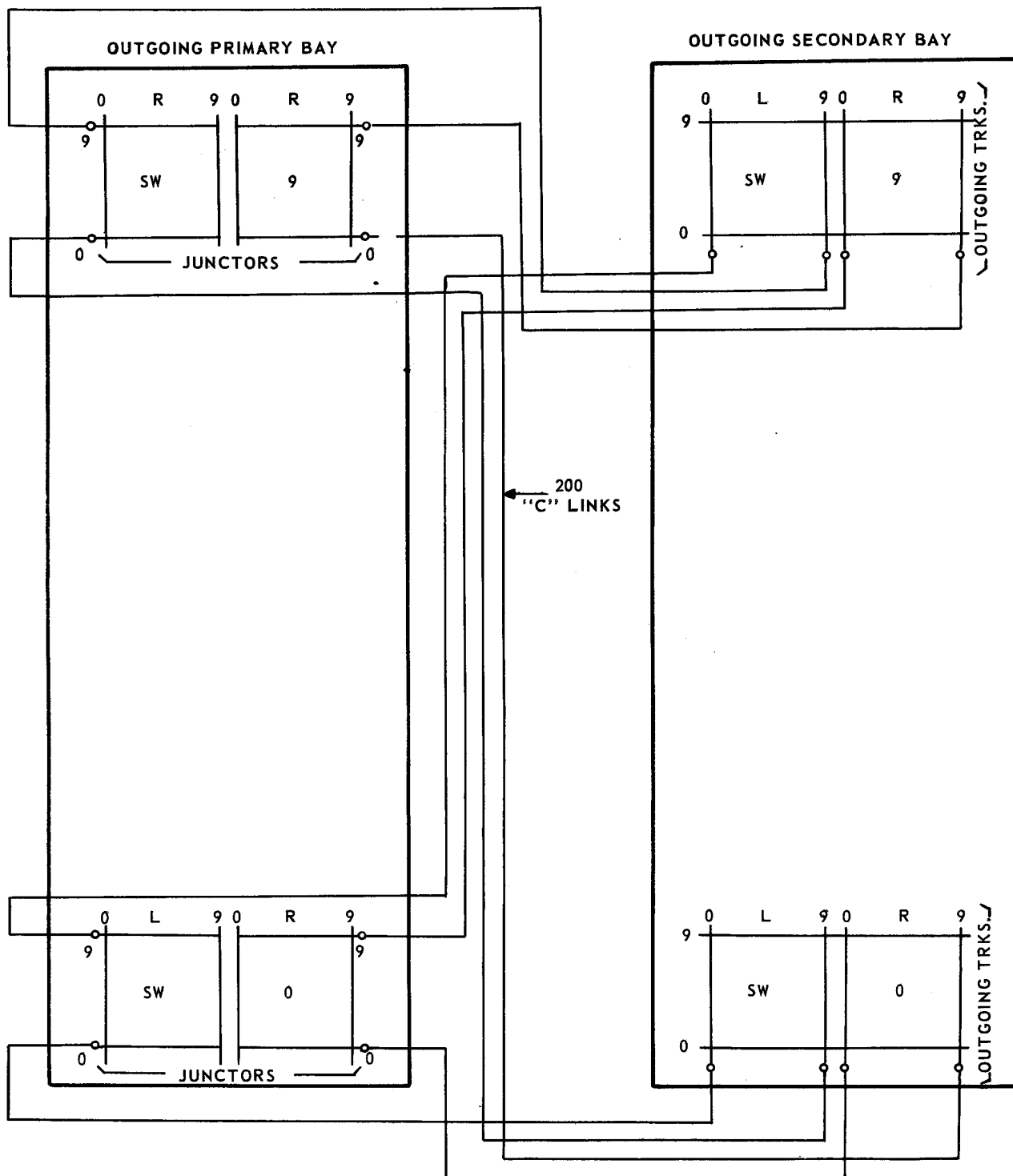

Figure 10-8 - "C" Link Distribution

incoming frame, there are twenty incoming or "A" links (10 left and 10 right) serving it. These are spread over the ten secondary switches of the incoming frame. Considering a particular outgoing trunk on an outgoing frame, there are twenty outgoing or "C" links (10 left and 10 right) serving it. These are also spread over the ten primary switches of the outgoing link frame. Thus between a particular incoming trunk and a particular outgoing trunk, there are ten or more channels available for connection. A diagram for channels is shown in Figure 10-9.

The channel number corresponds to the incoming primary vertical number on which the "A" link appears, to the incoming secondary switch number, to the outgoing primary switch number on which the "B" link appears, and to the outgoing secondary switch vertical number on which the "C" link appears. The channel number is thus an important association of equipment, for it facilitates tracing a connection from an incoming to an outgoing trunk.

#### 5. Increasing Frame Capacity

Previously, only a primary bay which always has a capacity of 100 incoming trunks was mentioned, in order to simplify explanation of the switching principles. As can be seen, it would be uneconomical to provide only 100 trunks to have access to 200 links and 200 junctors. Therefore, a primary extension bay is always provided on incoming frames to increase the capacity to 200 incoming trunks. A second primary extension bay may be furnished where it is desired to increase the capacity to 300 incoming trunks. And similarly a third primary extension bay where it is desired to increase incoming trunk capacity to 400 trunks. The verticals of the primary bay are multiplied to the verticals of each extension bay to share the use of the 200 "A" links, Figure 10-10a.

INCOMING FRAME #0

SECONDARY SWITCH #9

PRIMARY SWITCH #9

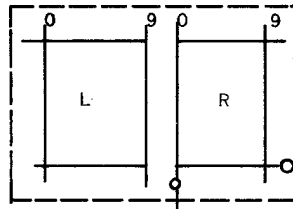
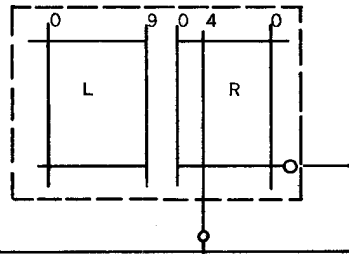

\*\*B\*\* LINKS

CHANNEL NO 9R

INCOMING TRUNK

PRIMARY SWITCH

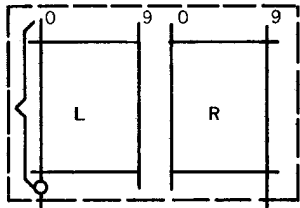

SECONDARY SWITCH

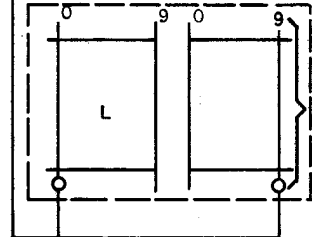

OUTGOING TRUNKS

\*\*A\*\* LINKS

\*\*C\*\* LINKS

CHANNEL NO. 0L

SECONDARY SWITCH #0

PRIMARY SWITCH #0

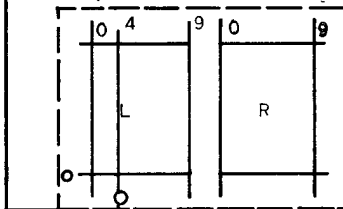

\*\*B\*\* LINK

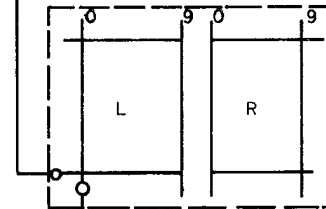

10.19

Figure 10-9 - Channels

CH. 10 - 4A TOLL SWITCHING SYSTEM

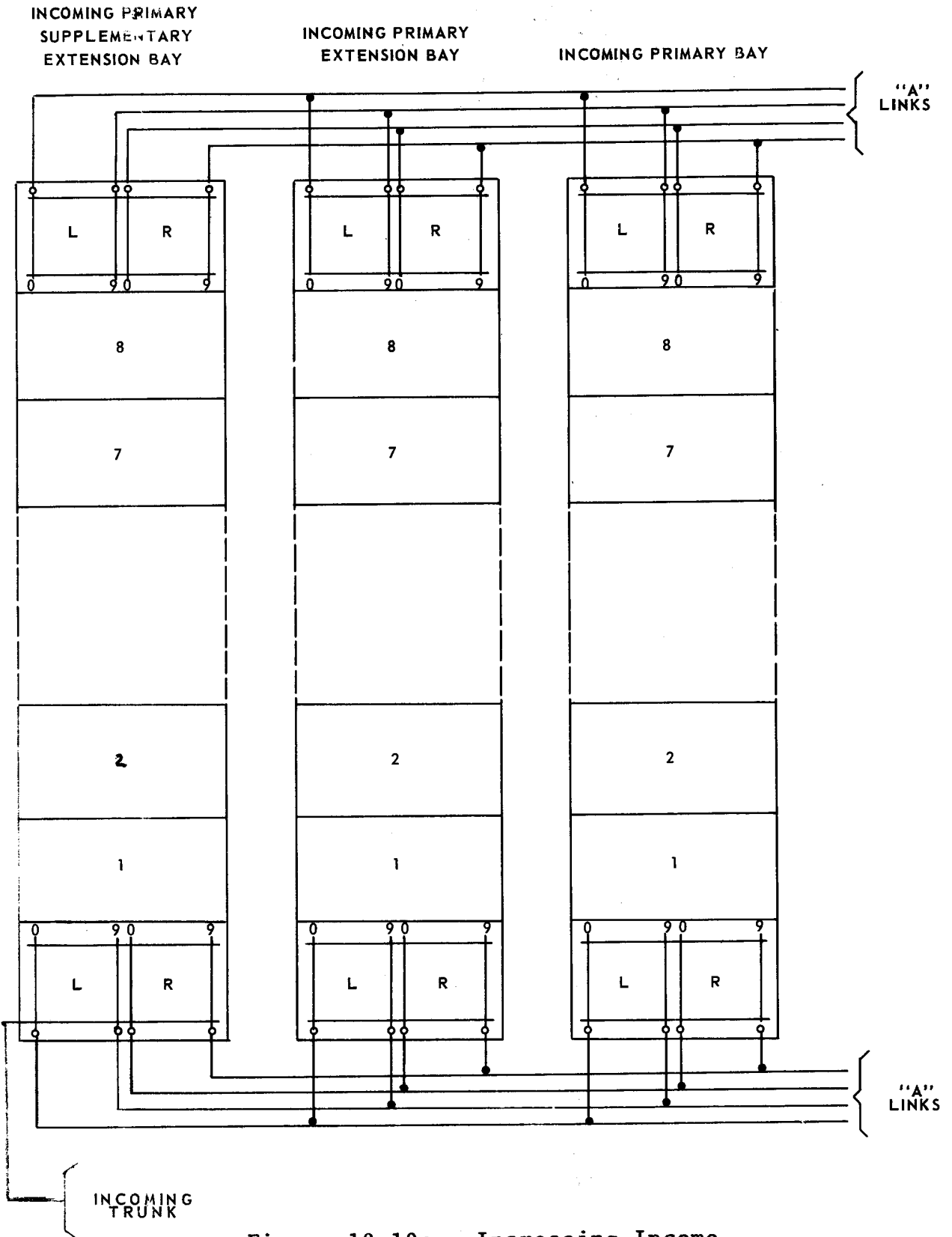

Figure 10-10a - Increasing Income Frame Capacity

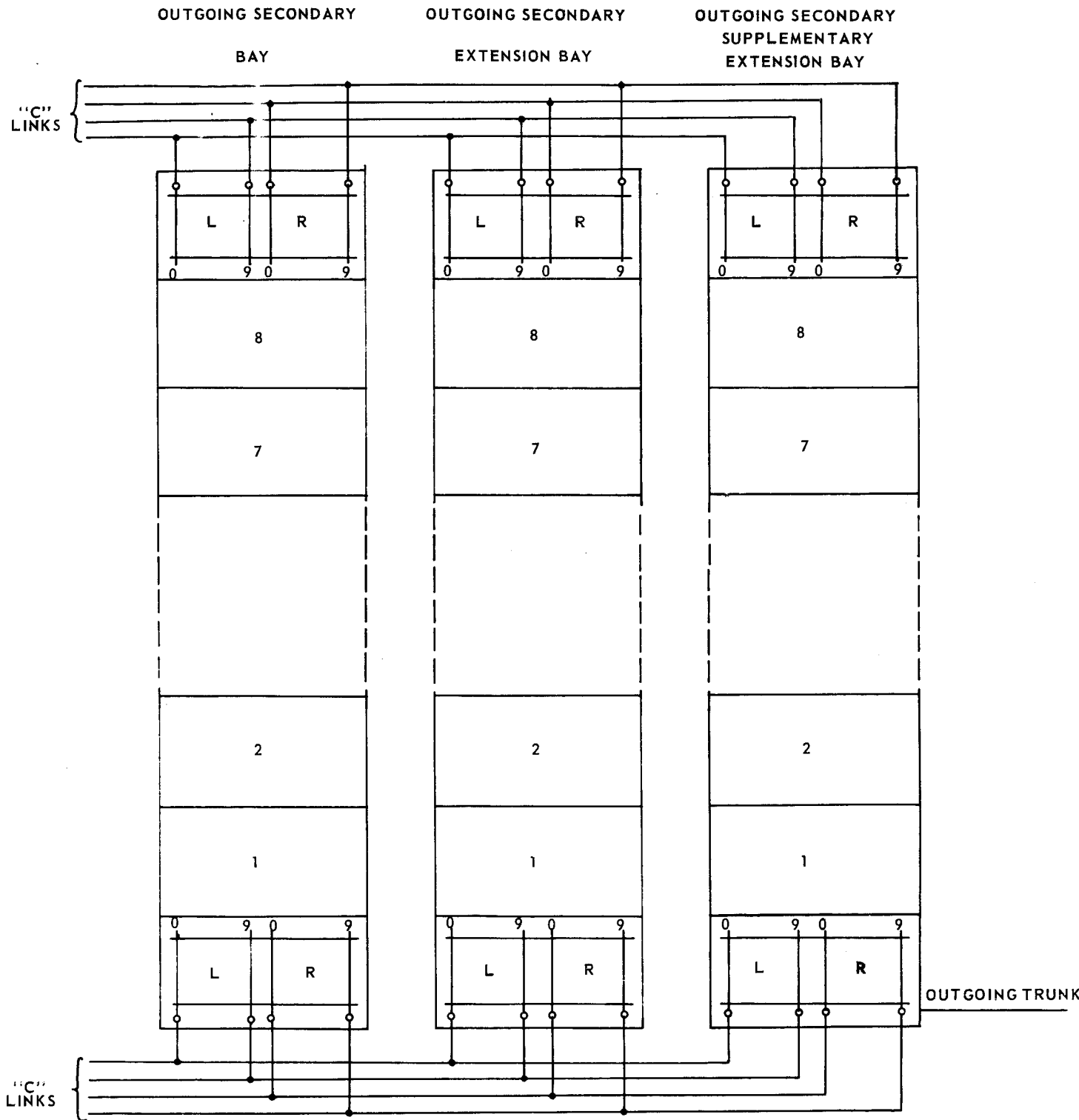

Figure 10-10b - Increasing Outgoing Frame Capacity

Likewise, as referred to in a previous paragraph, the secondary bay of an outgoing frame terminates only 100 outgoing trunks. For the same reason as stated above, a secondary extension bay is always furnished to increase the capacity to 200 outgoing trunks. A second secondary extension bay may be furnished where it is desired to increase the capacity to 300 trunks. The secondary extension, and the second secondary extension bays have the same switch arrangements as the primary bays on an incoming frame, Figure 10-10b.

### C. SENDER LINKS

The primary function of a sender link frame is to associate any one of 100 trunks with any one of 40 senders of the proper type. Three types of sender link frames arranged for single class sender access are part of the 4A Toll Switching System. They are:

Incoming MF Sender Link Frames  
Incoming Dial Pulse Sender Link Frames  
Outgoing revertive and PCI Sender Link Frames

The sender link frame terminates ten trunk groups each on the horizontals of the primary switches and 40 senders on the horizontals of the secondary switches. Each frame includes sixteen 100-point, 6-wire switches mounted in two bays. Eight switches are primary and eight are secondary. The switches are divided into two groups, "A" and "B" units, permitting independent operation of either unit.

Figure 10-11 indicates provisions for terminating 12 leads from each trunk circuit on the horizontals of the "A" primary switch. (Note: This is increased to 18 leads when used for CAMA and overseas calls.) These leads are multiplied to the horizontals of the "B" primary switches. The 12 leads from each sender terminate on the horizontals of two secondary switches.

The primary switch verticals are strapped horizontally in pairs, two such pairs being required to carry the leads comprising two links. Each group of ten trunks has access to two links through an "A" primary switch and to two links through a "B" primary switch. The leads from ten trunks are therefore connected to the horizontals across two pairs of "A" switch verticals and a multiple is provided to the corresponding horizontals on the "B" primary switches. The

links between the primary switch verticals and the secondary switch verticals find their outlet at the secondary switch horizontals which provide access to the senders.

Each group of ten trunks is served by four links, each link having access to a maximum of ten senders. Any trunk, therefore, may have access to each one of four groups of ten senders or less on the frame.

The vertical number of the primary switch is the same as the secondary switch number on which it terminates. The vertical number on the secondary switch is the same as the incoming trunk group number on the primary switch on which it terminates. This is known as vertical to vertical spread. Connections between trunks and senders are set up by controllers which are reached by the sender link frame through controller connectors. Senders of a type can be connected to a sender link frame in groups of 80 maximum on a "key" frame basis. The latest arrangement for connecting senders to sender link frames, known as "Simplified Sender Grouping" involves the assignment of no more than 40 senders to each sender link frame group. The "key" frames are the first four sender link frames of a group, and are interconnected with a slip multiple which is arranged so that when there are 40 or less senders, all senders appear on all link frames. When the number of senders exceed 40, the additional senders, up to 80, are introduced into the slip multiple in such a way that each sender has appearances on two key frames. Thus, each sender link frame has access to 40 senders, but not always the same combination of 40.

#### D. DIVISION OF COMMON CONTROL FUNCTIONS

The arrangement of crossbar switches used for the talking connections between an incoming trunk and an outgoing trunk has been discussed in the preceding chapters. With the exception of the sender link frames, the cross-points on all switches used for a call remain closed for its duration. The problems of controlling the switches may be understood by considering the operations required to set up these connections. The problems, in appropriate order, are as follows:

- a. The calling trunk must be identified.
- b. An idle sender with an idle link available to it must be selected.

CH. 10 - 4A TOLL SWITCHING SYSTEM

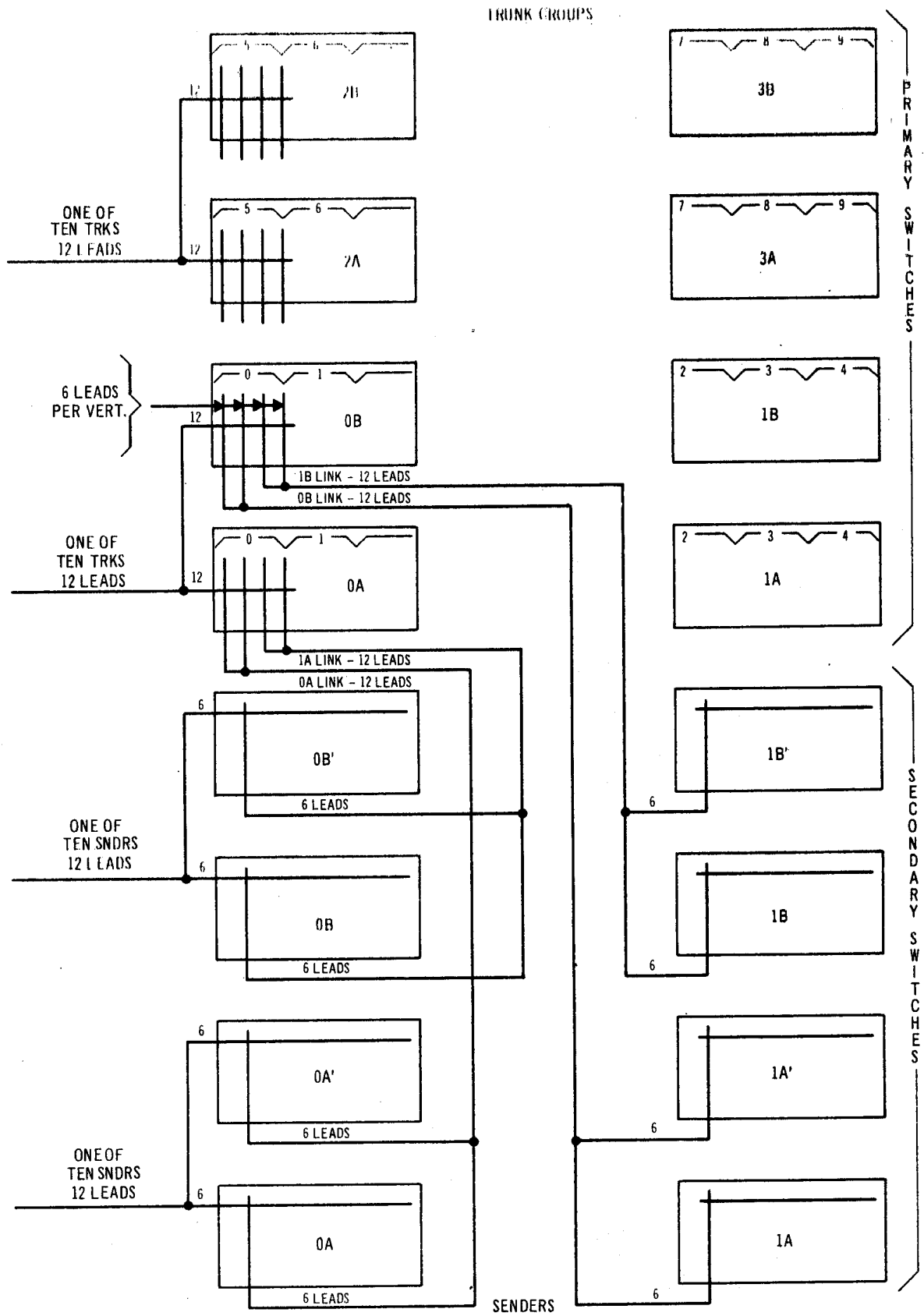

Figure 10-11 - Sender Link Frame - Sender Link Spread



- c. The various select and hold magnets in this chain must be operated to set up the connection between the trunk and the sender.
- d. The number pulsed over the incoming trunk must be recorded in the sender.
- e. The route, in general, must be determined from the first three digits of the number or translating a six digit code for selection of correct route when more than one route exists to another NPA.
- f. An outgoing trunk for this route must be selected.
- g. An idle channel between the incoming and outgoing trunks must be found and marked.
- h. The various select and hold magnets in this chain must be operated to set up the connections between the two trunks.
- i. The required number of digits, recorded in the sender, must be passed on through the outgoing trunk to control the circuits which establish the connection to the called line.
- j. The sender link crosspoints must be released.
- k. The incoming and outgoing trunk must be cut through for talking with supervision.

It is obvious that to provide so much "built-in intelligence" in a large number of circuits would be very costly. Therefore, every effort was considered in the design of the 4A Toll Switching System to concentrate the control operations in as few circuits as possible. Since these few circuits which have the necessary intelligence are used in common for establishing all the connections, the 4A Toll Switching System is known as a "common control system."

In the above list of operations necessary to set up a connection, it is evident that items "d" and "i" stand apart from the other items in that they necessarily require much longer periods of time. The time required to record the number dialed, the time required to transmit pulses to the connecting office, and, in some cases, the readiness

of the connecting circuits to receive the pulses all contribute to this extended time period. Therefore, items "d" and "i" and also "j" and "k" are handled by one group of common control equipment known as senders.

On the other hand, the remaining operations are such as may be completed with very rapid actions. Therefore, items "a", "b", and "c" are performed by a group of common control equipment known as link controllers. Items "e" through "h" are performed by another group of common control equipment known as translators, decoders, and markers. These various groups of common control equipment will be discussed subsequently.

One of the definite advantages of common control operation is that relatively few circuits need be provided to set up connections. Because of the limited number of such circuits, they are equipped with self-checking and service - safeguarding features. In addition, many features, such as second attempts to complete a connection, alternate routing, and automatic recording of trouble, can be economically provided.

The number of switching control elements provided in each installation is dependent upon the number of calls requiring their services and the length of time required to complete their functions. The switching control and associated elements used in a 4A system are as follows:

- a. Senders
  - Incoming
    - Multifrequency Pulsing
    - Dial Pulsing
  - Outgoing
    - Panel call indicator pulsing
    - Reverting pulsing
- b. Controllers
  - Link controllers and connectors
  - Decoder connectors
  - Marker connectors
  - Truck block connectors
  - Foreign area translator connectors
- c. Decoders
- d. Translators
- e. Markers

1. Incoming Sender

Two types of incoming senders are employed in the 4A Toll Switching System; Incoming Dial Pulse and Incoming Multifrequency Pulse Senders. However, there are three types of MF senders. These are (1) Regular Toll - 11 digits, (2) CAMA - 10 digits and (3) Overseas - 14 digits. The major functions of the incoming sender are to register the incoming digits and to outpulse them, according to directions from the marker, to a connecting office or to an outgoing sender. The outpulsing capabilities and digit capacities of the two types of incoming senders are identical. They have a maximum capacity of 11 digits, consisting of a three digit toll code, a three digit office code, and five numerals. One of the numerals may be a party letter or ringing code. The Multifrequency senders register MF pulses from switchboards equipped with MF key sets or from senders in other automatic offices which can transmit MF pulses. Dial Pulse senders register digits from switchboards equipped with dials or from senders which transmit dial pulses.

Although they register different kinds of pulses, these senders can out-pulse both MF and DP in accordance with the needs of the next office. For example, a call switched to a step-by-step office requires the incoming sender to spill forward dial pulses. This same sender can be used on another call to spill forward MF pulses.

The methods by which incoming senders dispose of their information are determined by characteristics of the called trunk circuits. These methods are briefly described as follows:

- a. When completing to step-by-step equipment, dial pulsing is employed.
- b. When completing to toll and local crossbar equipment, (when local crossbar is arranged to receive MF pulses) multifrequency pulsing is used.
- c. When completing to a trunk requiring revertive or panel call indicator pulsing, an outgoing sender is employed. The incoming sender spills forward d-c pulses to the outgoing sender.

The outgoing sender then converts these pulses to revertive or panel call indicator (PCI) pulses and spills them forward to the local office over the outgoing trunk.

- d. When completing to manual trunks, no pulsing is required.

The design of the 4A Incoming Sender incorporates certain spill forward and code conversion features which enable a 4A sender to perform the following functions under control of the decoder and marker.

1. The sender may spill forward all digits received up to a maximum of 11 digits or may generate any 1, 2, or 3 additional digits and outpulse these ahead of the received digits for a maximum of 14.
2. The sender may drop the first three digits and spill forward the remaining digits (maximum 8) or may generate any 1, 2, or 3 digits and outpulse these ahead of the remaining digits (maximum 11).
3. The sender may drop the first six digits and spill forward the remaining digits (maximum 5) or may generate 1, 2 or 3 digits and outpulse these ahead of the remaining digits (maximum 8).

## 2. Seizure of the Incoming Sender

Upon receiving a signal from a sender in a distant office, or from an operator, the incoming trunk in the 4A office signals the sender link to connect an incoming sender. When the incoming sender is attached to the incoming trunk and is ready to receive pulses, it signals to the operator or sender in the distant office to begin outpulsing as shown in the simplified block diagram of Figure 10-12.

Dial Pulse Sender: When an operator receives signal from the sender, she dials the called number. For example, 212-MU2-1234 is dialed by the operator and registered in a DP incoming sender in the 4A office. On some calls, the decoder and card translator tell the sender how

many digits to expect. On other calls, the sender just waits a short while to make sure that all the digits are received.

Multifrequency Sender: When an operator at a switchboard equipped with MF keysets receives a signal, she keys KP 212-MU2-1234 ST. The same digits are pulsed when this call is outpulsed by an MF sender in a distant office instead of by an operator.

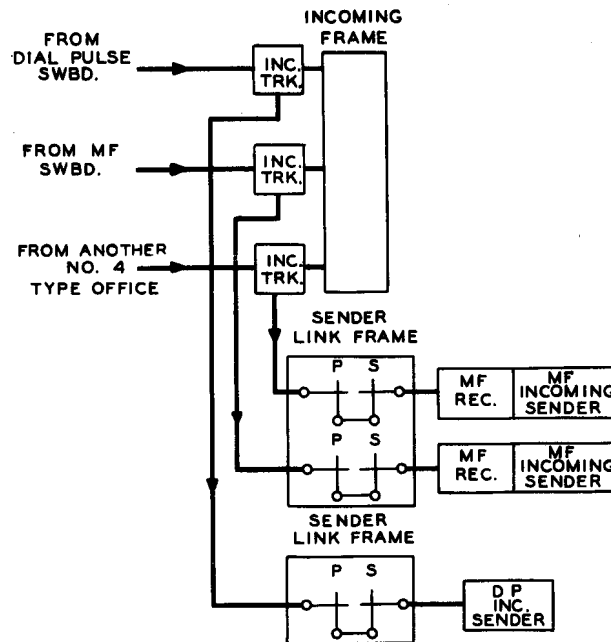

Figure 10-12 - Access to Incoming Senders

After at least three code digits are registered, the incoming sender seizes a decoder and marker which instruct the sender how to outpulse the called number. These instructions will tell the sender:

1. The kind of pulses to be spilled forward.  
(MF DP or DC)
2. How many of the registered code digits are to be spilled forward.

3. Whether any of the code digits should be converted before spilling forward.
4. Whether any code digits should be prefixed before spilling forward.
5. Not to output anything (for example, on a call to a manual office.)

The incoming sender prepares to output the registered digits in accordance with these instructions. In the meantime the marker has established a channel between the incoming trunk and the outgoing trunk. The sender waits for a signal from the distant office, or from an outgoing sender in the same office, that it is ready to receive the pulses. Upon receipt of this signal, the incoming sender spills forward the digits, as instructed, via the sender link, incoming trunk circuit, incoming link frame, outgoing link frame, and outgoing trunk circuit to the distant office or outgoing sender.

At the end of outputting, the incoming sender and sender link release, leaving the transmission path through the incoming and outgoing link frames. In cases where the call is to a manual office and no outputting is required, the sender simply checks that an outgoing trunk is attached and releases.

### 3. Outgoing Senders

Outgoing senders may be seized only by a trunk appearing on an outgoing frame by means of an outgoing sender link frame. The trunk must be of a type that requires outputting on a revertive or panel call indicator basis.

The outgoing sender receives and stores d-c key pulses from an incoming sender, and disposes of the digit information via the called trunk.

When a sender, either incoming or outgoing, has disposed of digit information it disengages from the connection and is available for the handling of other calls.

4. Link Controllers and Connectors

The link controllers are the equivalent of simple markers and perform the functions of selecting an idle incoming sender of the desired type, securing an idle link on the sender link frame, and operating the crosspoints which connect the sender to the incoming dial or MF trunk as illustrated in the simple block diagram of Figure 10-13.

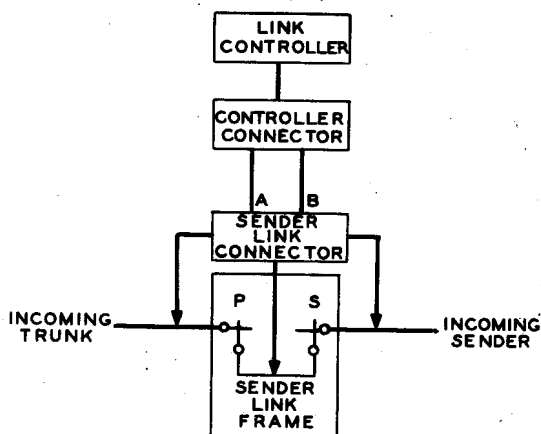

Figure 10-13 - Link Controller Operation

Each sender link connector has access to two controller connectors. When an incoming trunk signals for an incoming sender the sender link connector signals one of the controller connectors (depending on which is available, or if both are available, which one is preferred at that time) to connect to the link controller.

Test leads associated with the incoming trunks, the sender links, and the senders are closed through the sender link and controller connectors to the link controller. The link controller then tests for and selects an idle sender and sender link and connects the incoming trunk to the sender. The controller then releases from the connection and is ready to serve other calls.

The sketch in Figure 10-14 shows the sender link access to controller connectors when a group of six controllers is used. Under the Simplified Sender Grouping arrangement, only 4 controllers are used in a sender link group.

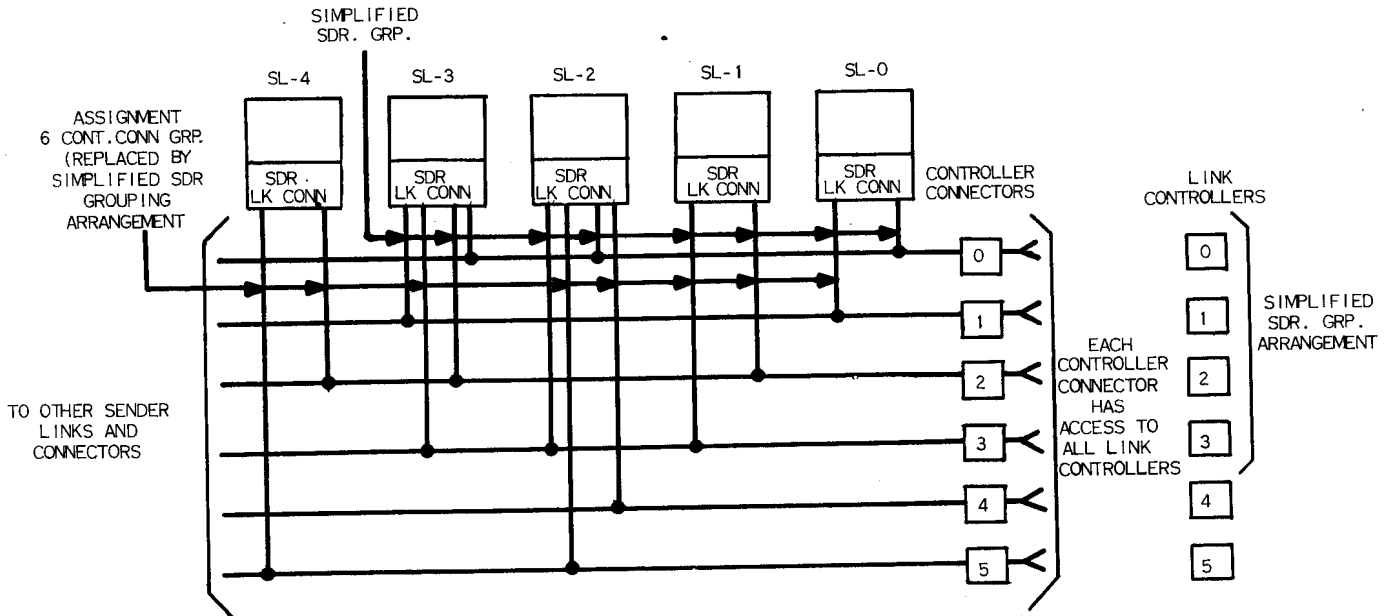

Figure 10-14 - Sender Link Access to Link Controllers

5. Decoder Connector

Decoder Connectors which are made up of a group of multicontact relays are used to connect an incoming sender to a decoder and later in the call (when the decoder seizes a marker) to connect the incoming sender directly to that marker. All senders have access through these connectors to all decoders and all markers in an office.

When an incoming sender signals for a decoder, a chain circuit in the selected decoder connector selects an idle decoder and cuts through the necessary leads by operating its multicontact relays. When this decoder signals a marker



connector to seize an idle marker the marker connector then signals the decoder connector to operate the multicontact relay associated with marker. This ties the incoming sender to the marker used on this call. When the decoder is released, the incoming sender remains connected to the marker until the marker completes its functions. Then the marker and the decoder connector are released.

#### 6. Marker Connector

The marker connectors provide facilities for cutting through a large number of leads between the decoder and a marker. In addition, the marker connector also signals the decoder connector to cut through some leads between the incoming sender used on the call and the selected marker.

When a decoder signals a marker connector to seize an idle marker, the chain, or preference circuit, selects any idle marker (in a combined train office) and the marker connector operates the multicontact relays which cut through the leads from the decoder to the marker. Then the marker connector signals the decoder connector to cut through the incoming sender used on the call to the selected marker. The marker connector releases when the decoder is released from the call.

In a two train office, the marker connectors are equipped with two chain or preference circuits. One chain for the intertoll markers and the other for the toll completing markers. When a decoder signals a marker connector for a marker, the decoder also tells the marker connector which kind of marker is required. The other functions of the connector are the same as those described for the combined train.

#### 7. Trunk Block Connector

An outgoing trunk group is spread over at least two outgoing link frames. In order to facilitate the checking of these trunks, leads from each of the outgoing trunks are brought to trunk block connectors and grouped according to destination. In this way, a marker goes to only one place to test trunks that may be spread over many outgoing

link frames. A marker seizes the proper trunk block connector in accordance with the information obtained from a decoder and card translator. There a marker tests for and seizes an idle outgoing trunk.

A trunk block connector contains the appearances of up to 400 outgoing trunks. These trunks are arranged in groups of forty which is the maximum number a marker can test at one time. A trunk block connector consists of an "even" half connector and an "odd" half connector. Each half connector is an exact duplicate of the other and is designed in this manner so as to increase marker access and service protection. This arrangement is shown in Figure 10-15.

The 400 trunks appearing on each half connector are divided into two groups, 0 and 1 of 200 trunks each. When a marker seizes group 0 in the even half connector, all other markers are locked out of this connector and group 0 on the odd half connector.

Another marker, however, can seize group 1 in the odd half connector. The preference for a particular trunk block connector depends on the number of the sender used in the call. A marker connected to an even numbered sender prefers an even half connector while a marker connected to an odd numbered sender prefers an odd half connector.

A trunk block relay cuts in the leads for the 40 trunks connected to its terminals but the "group start" and "group end" data on the translator cards confine the marker trunk test to the particular span of terminals containing the called group of trunks. All trunks of a group or subgroup, including spares and recorded announcement trunks, if any, are assigned to one trunk block relay if there are 40 or less terminals involved. Trunk groups which require more than 40 terminals are assigned in multiples of 40 trunks to other trunk block relays. However, more than one trunk group may be assigned to the same trunk block relay provided the total trunks do not exceed the 40 terminal capacity.

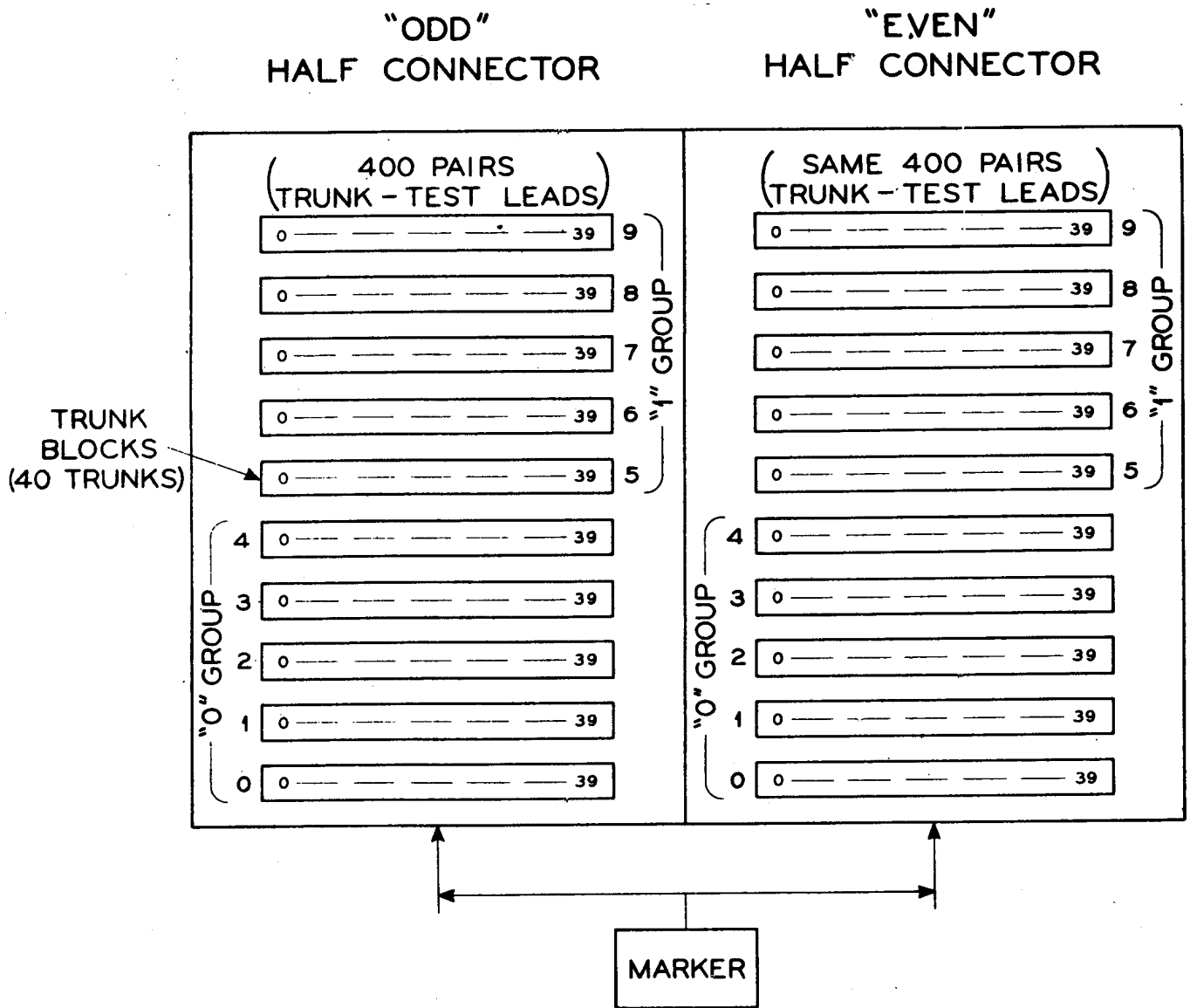

Figure 10-15 - Trunk Block Connector

8. Foreign Area Translator Connectors

One translator connector per "foreign area translator" is provided to cut through approximately 180 leads between a decoder and a translator. One translator connector frame will accommodate

two translator connectors. However, as odd and even numbered connectors are located on separate frames two translator connector frames are required when exactly two foreign area translators are provided.

9. Decoders

The decoder, in conjunction with the card translator, performs the function of decoding the digits registered in the incoming sender into information on outgoing trunk selection, alternate routing, code conversion, variable spilling of digits, and outputting class and transmits this information to the marker.

In an office not using the "increased-capacity" features, a maximum of 18 decoders may be provided. With "increased-capacity," as many as 24 decoders may be provided.

When a decoder is seized by an incoming sender for the first time, the decoder always sends the first three digits registered in the sender to the home translator. The sender may or may not have additional digits registered, at this time, beyond the initial three sent. Here a card corresponding to these three digits is dropped. This procedure can be considered a starting point for obtaining a translation on every call. Any further action that the decoder takes is determined by the information contained on the first card as follows:

- a. Three digit translation: If the first card indicates that it has enough information to switch the call, then the decoder signals a marker connector to seize an idle marker. The decoder then passes the information it obtains from the card to the marker. The call is then completed in the usual manner.
- b. Pretranslation: When more than three digits are required to obtain a translation, the first card dropped indicates specifically how many digits are required. For example one card indicates that four digits are necessary for a certain call; another card indicates that five digits are required for another

call; another card indicates that six digits are required for a particular call. In all these cases the decoder action is the same. If pretranslation option is not used or if the sender has enough additional digits registered, the decoder will not release. If this is not the case and more digits are required, the decoder restores the card, signals the incoming sender that more digits are required, releases from the sender, and is available for servicing other calls.

- c. Six Digit Translation: After pretranslation has taken place and the sender has the six digits available, it seizes an idle decoder through a decoder connector. Again the decoder drops an identical 3-digit card in its home translator. At this point the sender signals the decoder that six digits are available. This card then directs the decoder to a card translator which has the card corresponding to the six code digits. The decoder restores the first card and reaches out to the proper card translator and drops the 6-digit card. The decoder reads and decodes the information on the card and signals for the marker. The marker then completes the call.

Other important items of information that the decoder gets from the card and passes to the marker is the location of the outgoing trunks that can be used for a particular routing. The location of a maximum of 40 trunks can be obtained from one card. If there are more than 40 trunks for a particular routing, then two or more cards are necessary. When there are two or more cards available, a decoder can operate in one of three different modes:

- a. Card to Card: The decoder advances from one subgroup of 40 trunks to another subgroup of trunks by presenting the appropriate information from a series of cards to a marker which then tests for idle trunks in these subgroups.
- b. Relay to Relay: The decoder does not present the information from a series of cards to the marker for finding an idle trunk. The decoder first checks for availability of trunks in

both direct and alternate route trunk groups by means of group busy relays. If none of the trunks associated with the first card are idle, a second card will not be dropped unless a group busy indication indicates that the second card will be associated with an idle trunk.

c. Card to Relay: This is a combination of the above two types.

10. Decoder Route Relays

One decoder route relay is provided for each intertoll trunk group to a primary center, sectional center, or regional center, which is to be used as an alternate route. A route relay is also provided for each trunk group to a crossbar tandem office which is to be used as an alternate route. The number of route relays per decoder to be provided will vary from a minimum of 30 to a maximum of 100.

11. Card Translator

There are two types of translators commonly used in the 4A Toll Office, Home Translators and Foreign Area Translators. Each of these translators has a capacity of 1,176 working cards.

The card translator is literally the "seeing eye" of the 4A common control equipment. It translates the code digits registered in the incoming sender into information which is used by the common control equipment to switch a call. The card translator gets its name from the fact that metal cards are used in the translation process instead of the relay type translator used in all other common control systems.

Card translators are equipped with metal cards, coded, to provide the switching information for all calls arriving at a No. 4A Toll Office. As shown in Figure 10-16 each card has 40 tabs and 118 holes. The tabs are used to code the card to correspond to a called code. This is accomplished by removing some of the tabs so that the remaining tabs are arranged in a definite pattern which is unique for that card. This tab coding is called the input information. The holes in

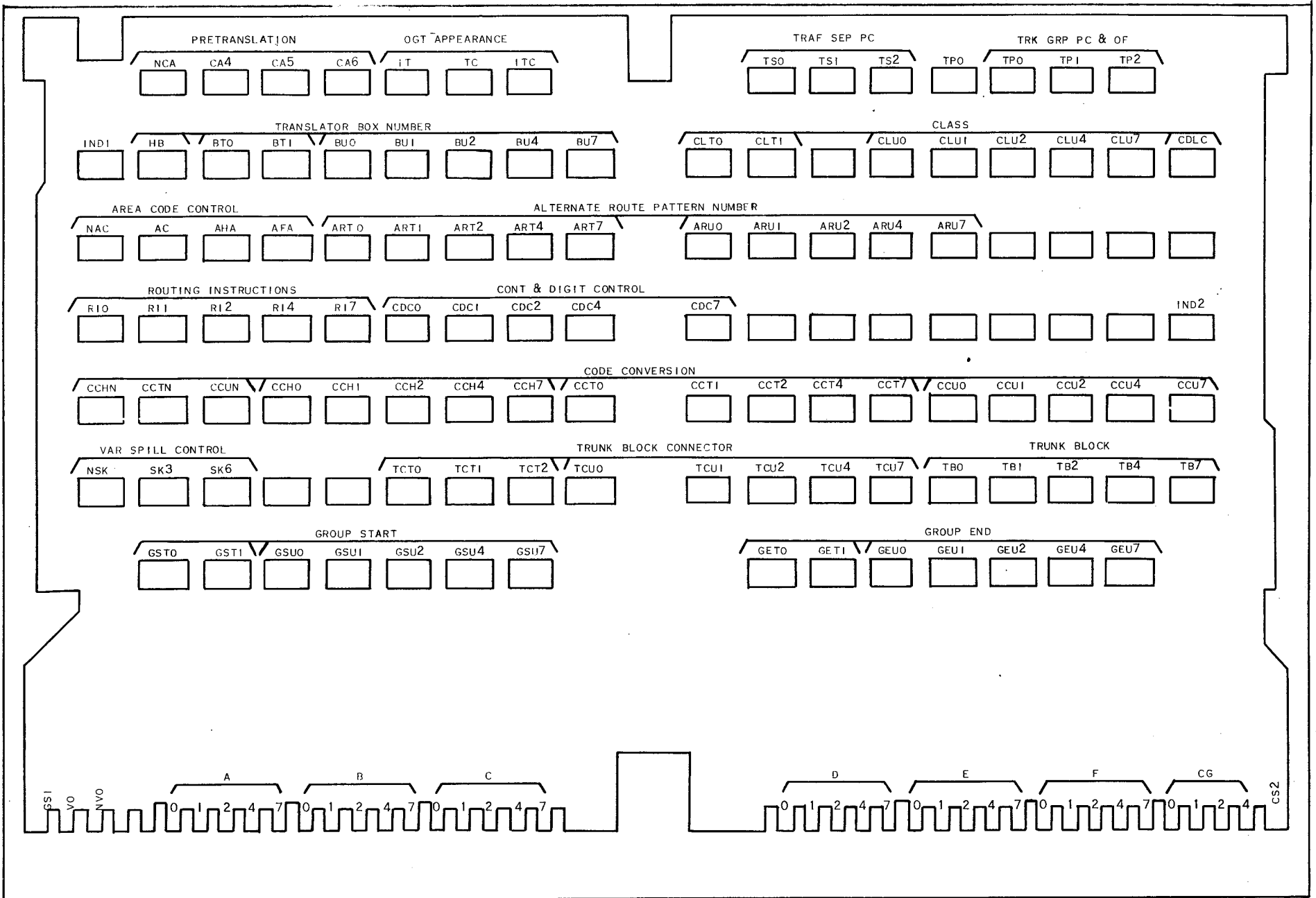

Figure 10-16 - Translocator Card

the card are also coded to correspond to the switching information needed for the called code represented by the card. The switching intelligence is applied to the card by enlarging the pertinent holes, and is called the output information.

The basic elements of the translator consists of a light source modulated at 400 cycles, a bank of light sensitive photo transistors and a stack of perforated cards. The cards are stacked between the light source and the photo transistors, of which there is one for each hole in the card. When the cards are in their normal positions the holes in the cards form 118 continuous tunnels or light channels between the light and the transistors. When the translator is operated, that is when a card is dropped about 1/8 inch, all of the light channels are blocked except for those holes which have been enlarged. Figure 10-17 shows a schematic of the translator, and Figure 10-18 indicates the effect of a dropped card on the light channels.

The selection and dropping of a card is accomplished by means of the card tabs and a group of code bars. The tabs correspond in position to, and rest directly on, 40 rectangular bars located at right angles to the cards. As mentioned before, a unique group of tabs are left on the card to agree with the code represented. Figure 10-19 shows a card resting on the code bars when the translator is unoperated.

When the decoder connects to the translator, it depresses certain code bars by means of solenoids. The one card, whose tabs correspond to the depressed bars, is thus permitted to drop as shown in Figure 10-20.

The card drops a distance slightly greater than the height of uncoded (nonelongated) hole. Thus, the dropped card produces a shutter-effect on all light channels except those for which the card holes were enlarged. The open channels energize their photo-transistors and associated detector amplifiers. These circuits read the beams of light and transmit the information to the decoder.



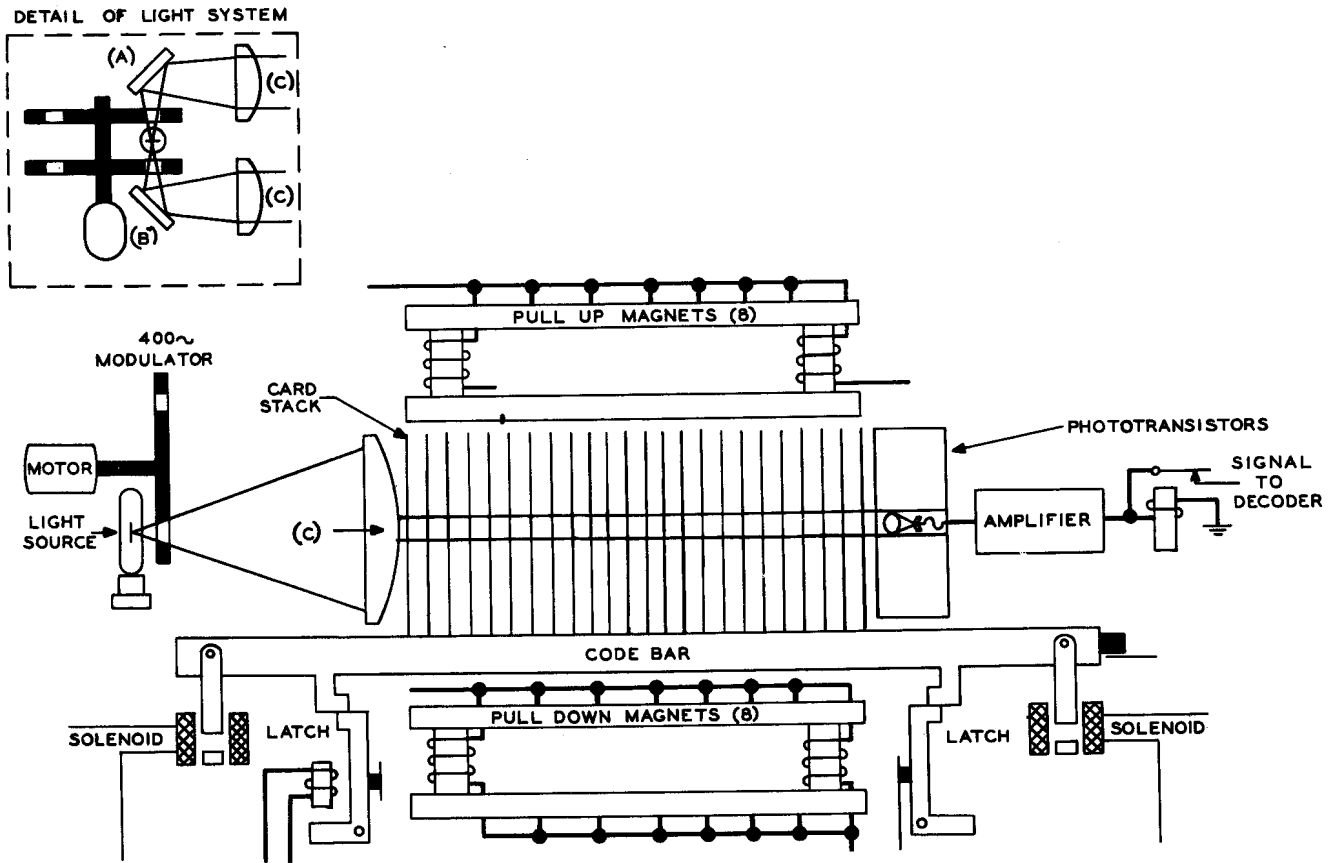

Figure 10-17 - Elements of the Card Translator

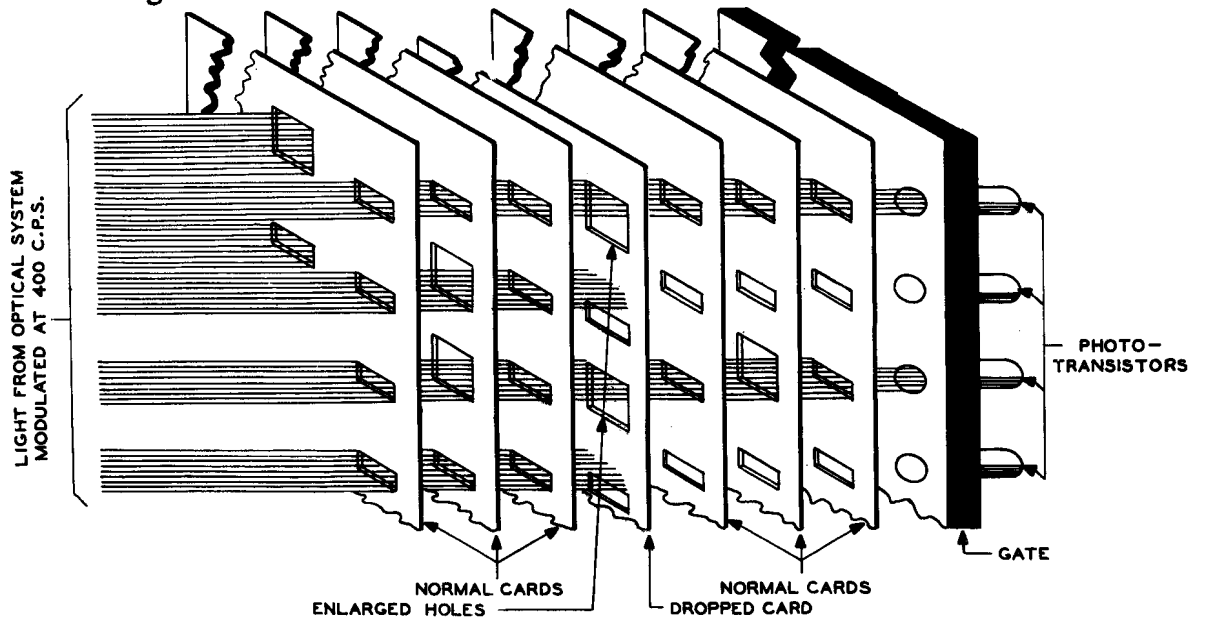

Figure 10-18 - Effect of Dropped Card on Light Channels

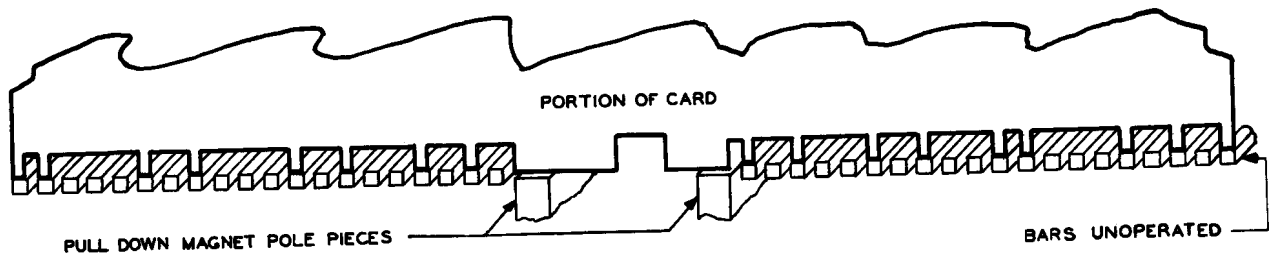

Figure 10-19 - Card Support and Code Bars Normal

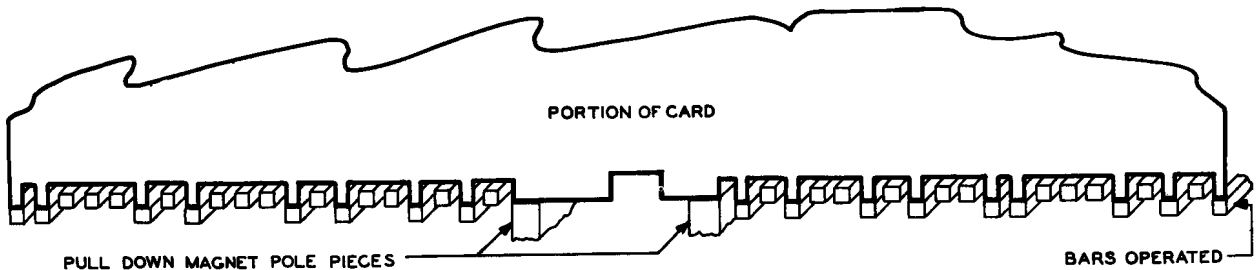

Figure 10-20 - Card Support and Code Bars Operated  
(Corresponding Card Drops)

Home Translator: One home translator is directly associated with each decoder in the office. On every call, once a decoder is seized, it drops a three digit card in its own home translator. Any decoder can handle any call, therefore all the home translators in the office contain identical sets of cards. If a three digit card fails to drop, the decoder releases and gives a second trial indication to the decoder connector. The connector would then select another decoder and a second attempt is made to drop an identical card. If the card drops, the call goes to completion and the decoder calls in the trouble recorder which records the failure to drop a card on the first attempt. The home translator does two things:

- a. provides switching information for calls requiring 3 digit translation.
- b. directs decoder to foreign area translators for calls requiring 4, 5, or 6 digit translation, if the home translator is not arranged to handle the particular call in question.

Foreign Area Translator: Each foreign area translator contains all of the 6 digit cards required for completion of calls to several particular foreign areas. For example, one translator may contain all of the cards for three foreign areas and another for five foreign areas. Therefore, unlike home translators, a particular foreign area translator must be used on each call. Each foreign area translator is available to all decoders through the foreign area translator connectors. Foreign area translators may be paired or nonpaired.

Paired. If there is no principal city routing for certain calls, the translators may be paired. In this case both translators of the pair would have identical cards.

Nonpaired. Nonpaired translators contain 6-digit cards for calls which, if routing is not obtained at the foreign area translator, can be routed by principal city routing from the home translator without a second trial.

If a 6-digit card fails to drop in a paired translator, the decoder releases and gives the decoder connector a second trial indication.

## 12. Markers

The marker is one of the major equipment elements in the 4A toll switching system. It locates an idle outgoing trunk and identifies the incoming trunk handling the call. It then marks an idle path between them and establishes the transmission path. Markers in the 4A offices use information furnished by the card translators and decoders in establishing these connections as shown in Figure 10-21. Some of this information is used by the marker to seize a suitable outgoing trunk. The marker stores other information supplied by the decoder and card translator and later transmits it to the sender. This information instructs the incoming sender how to outpulse the registered digits.

Seizing an outgoing trunk: In a 4A toll office, all of the outgoing trunks (a trunk group), going to a certain distant office are spread over as many outgoing frames as is practical.

Figure 10-22 shows how information from the card translator and the decoder directs the marker to the proper trunk block connector which contains the leads of the desired group of trunks. Here the marker tests for an idle trunk and seizes the first one available. As soon as a trunk is seized, a signal is sent to the distant office telling it to expect a call on this trunk.

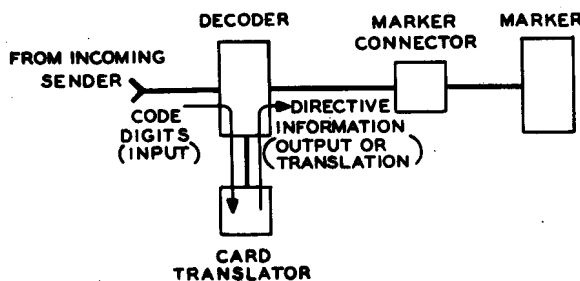

Figure 10-21 - Information to Marker

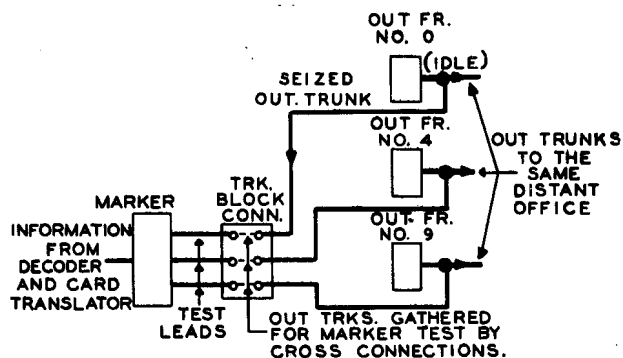

Figure 10-22 - Seizing and Outgoing Trunk

Identifying the outgoing frame: So far the marker knows that it has an idle outgoing trunk but it does not know the number of the outgoing frame on which this trunk appears. It must know this in order to establish the transmission path. The outgoing trunk supplies the outgoing frame number to the marker by sending a distinctive MF signal assigned to this frame over the select magnet lead associated with the trunk. This signal is extended to the marker through the trunk block connector, Figure 10-23 connection 2A.

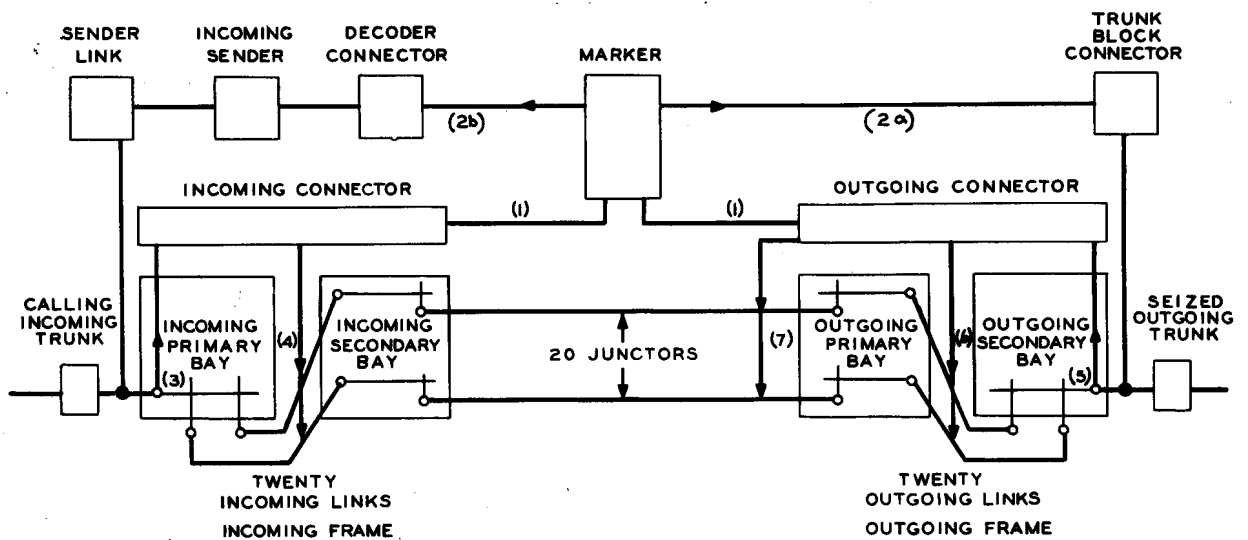

Figure 10-23 - Establishing a Channel

Identifying the Incoming Frame: The marker must also know the incoming frame number in order to establish the transmission path. Therefore the incoming trunk sends its distinctive MF signal identifying this number to the marker over the select magnet lead associated with this trunk. This lead is extended to the marker through the sender link, incoming sender, and decoder connector, Figure 10-23 connection 2B.

Testing Incoming and Outgoing Links: When the incoming and outgoing trunks have identified their respective frames, the marker reaches out to these incoming and outgoing frames by seizing their associated connectors on the marker connector frame. Figure 10-23 connection 1. Through these connector circuits the marker gains access to the incoming links, outgoing links, and junctors.

Information to the Incoming Sender: When the decoder and card translator send information to the marker, some of this information is used immediately and some is stored in the marker. This stored information is sent to the incoming sender when required. This stored information directs the incoming sender to output the digits in such a way that the needs of the next office are met. For example, if the call is switched to a step-by-step office then the sender spills forward dial pulses to direct the step-by-step switches toward the completion of the call. In another case, such as to another 4A office, the sender is directed to spill forward multifrequency pulses. If the call is to a manual office, the sender does not spill forward any digits.

Second Trial Feature: The marker has a second trial feature for making a second attempt to complete a call. Second trials are made if the marker encounters trouble, if the marker cannot match a channel, or if the marker is given a second trial routing instruction.

### 10.3 TRUNK EQUIPMENT AND TRAFFIC IN THE 4A SYSTEM

A trunk is a communication channel used as a common artery for traffic between switchboards or other switching devices. Trunk circuits consist of line facilities and trunk relay equipment. Trunk relay circuits provide the means by which the line facilities connect to the switching devices. These circuits are of various types, depending upon the types of traffic handled and the equipment to which they connect. Trunk relay circuits in the 4A System are designed for one-way or two-way operation. One-way circuits may be selected from one end only, they may be either incoming or outgoing. The two-way circuits are associated with intertoll trunks only. They may be seized from the distant end on an incoming basis or may be seized by common control equipment within the 4A System on an outgoing basis. Inasmuch as all switching is made on a four-wire basis, it is necessary to convert trunks which employ a two-wire transmission path to a four-wire. This conversion, which in general is required for all toll tandem and toll completing trunks, is obtained with hybrid coils. These coils are part of the associated trunk relay circuit. Trunk relay circuits associated with four-wire intertoll trunks do not, of course, require hybrid coils.

The 4A Toll Switching system provides switching facilities for toll traffic. The incoming traffic to a particular 4A installation originates either within its toll center area or from other toll center areas. This traffic is switched for local completion or for completion in other toll center areas.

Types of Trunks: The trunks of the No. 4A System may be classified as intertoll and toll connecting.

Toll connecting types include:

- a. Toll Tandem: completing and thru; C.A.M.A. trunks
- b. Toll Completing
  - LW trunks (Leave-Word formerly TX trunks)
  - 121 (inward assistance) trunks
  - Information trunks
  - Rate and Route
  - Delayed through position trunks

Miscellaneous type trunks include:

- a. Overflow
- b. Combined NC-operator
- c. Reorder
- d. Digit absorbing
- e. Test trunks

Intertoll Trunks: An intertoll trunk is an incoming, outgoing, or two-way trunk connecting the 4A System with other toll switching systems. The line facilities may be either two-wire or four-wire.

Toll Tandem Trunks: The toll tandem trunk is an incoming trunk connecting outgoing or DSA switchboards with the 4A System. These switchboards may be No. 1, 3, 3CL, 5 toll switchboards or any type of DSA switchboard. These switchboards, regardless of the type, are located within the toll center area. The various types of tandem trunks employ either dial or multifrequency pulsing. The 3-wire trunks transmit supervisory signals over the third wire. The 2-wire trunk employs the talking path for the transmission of pulses and supervisory signals. The 4-wire toll tandem trunk uses multifrequency pulsing and a sleeve path fifth wire for the transmission of supervisory signals.

Toll Completing Trunks: A toll completing trunk is an outgoing trunk from a toll switching unit to a local office, operator, or testboard in the toll center area. The term "toll completing" does not apply to a particular type of trunk, but does apply to various types of trunks that handle toll completing traffic. These are described briefly.

Toll switching trunks are provided for calls which are completed to subscribers served by various types of local and community dial offices. In general, toll switching trunks are arranged for dial pulsing to step-by-step offices, multifrequency or revertive pulsing to crossbar offices, revertive pulsing to panel offices, and panel call indicator pulsing to manual offices.

LW trunks are trunks to outward positions handling delayed traffic LW trunks for the purpose of reaching particular outward positions from other toll centers. These trunks employ direct current signaling, and usually require no pulsing on the part of the sender for completion.

Service trunks, such as 141 route operator, 131 information, 121 inward, 151 delay operator, 101 testboard, 102 milliwatt supply and others are considered toll completing trunks.

A. ASSOCIATED FRAMES

1. Alternate Route Traffic Control

The successful dialing of nationwide long distance traffic, by both operators and customers, depends on a high speed intertoll network so that "all trunks busy" conditions will infrequently occur, even during the average busy season. Alternate routing is one of the techniques that makes this possible. Actually, alternate routing is a method of advancing a call at a switching point by diverting it to a trunk group, other than the first choice group, when the first choice group is busy. Multialternate routing, a provision for more than one alternate route, is a feature of the alternate routing pattern in the 4A toll switching system.



The alternate route traffic control frame provides centralized facilities for interconnecting the alternate route relays of each decoder in accordance with the basic switching plan. Associated with each decoder route relay is a route transfer relay which can be used to prevent the alternate routing of traffic over a trunk group to a Central Switching Point that has been congested. The route transfer relays are controlled by the operation of traffic control keys located with their associated guard lamps on the traffic supervisory cabinet.

2. Frame Identification Frequency Supply

This frame mounts the oscillators, amplifiers, and mixing resistors for the frame identification frequencies used in the marker operation. The signal received from the oscillators is amplified, mixed with a three frequency alternating current signal, and distributed to the incoming and outgoing link frame and to the trunk block connector circuit associated with the jump hunt trunk routes. By means of these signals, the marker is enabled to identify any incoming or outgoing link frame or trunk group. Each frame identification signal consists of a combination of three different frequencies, each of which is supplied from a separate oscillator and amplifier and through separate mixer resistors. The frequency output from amplifier A is 425 cycles, from B 595 cycles, and so on up to the H amplifier, 1615 cycles, in steps of 170 cycles. These frequencies are combined through mixer resistors in such a manner as to provide 40 different signals each of which represents a certain incoming or outgoing link or trunk group. All of this equipment is furnished in duplicate and mounted on separate supply panels which for safety reasons, are located some distance apart.

3. Multifrequency Current Supply Frame

This frame mounts the oscillator units which generate the MF current for MF pulsing. The circuit generates the six frequencies, 700, 900, 1100, 1300, 1500, and 1700 cycles used for MF key pulsing from switchboards and testboards and for multifrequency outpulsing from senders. A minimum of two supply frames are furnished in each office to assure continuity of service.

Multifrequency Receiver Frame - The multi-frequency pulsing receiving circuit receives and amplifies MF pulsing signals and converts these signals into dc pulses to operate various code combinations of relays in the associated sender. The MF pulsing signals consist of an alternating current of six different frequencies which are combined to provide key pulsing and start signals, and digit codes as shown in Table 10-1.

TABLE 10-1

Frequency & Designation	0	1	2	3	4	5	6	7	8	9	KP	ST
1700-10											X	X
1500-7	X							X	X	X		X
1300-4	X				X	X	X					
1100-2			X	X			X			X	X	
900-1		X		X		X			X			
700-0		X	X		X			X				

4. Office Interrupter Frame

This frame is arranged to mount reciprocating bar-type interrupters which function to supply interrupted battery or ground to the various circuits in the toll switching office. A minimum of two frames is provided for each office so as to divide the load approximately evenly and minimize service reaction in event of the temporary failure of the motor or drive mechanism of a frame.

5. Circuit Busy Announcement Trunk

The CBA frame performs the following functions in the 4A Toll Switching System:

1. Provides indications directly to the decoders as to the lowest numbered subgroups in which there are idle trunks available on groups which are used for alternate routes.
2. Aids in disposing of certain types of calls when all intertoll trunks of a group are busy, and in these cases, provides the originating operator with information as to the availability of trunks.

3. Provides idle indications to toll operators in the same building for all outgoing intertoll trunk groups and groups to crossbar tandem.
4. Provides trunk group-busy indications at the traffic supervisory rack.
6. Traffic Measuring and Administrative Facilities  
Traffic Register Racks

The traffic register rack provides miscellaneous registers for recording for traffic purposes:

1. Overflow conditions on link frames, outgoing trunks, common reorder, no circuit, blank code, and system overload announcement trunks.
2. Group busy conditions on incoming trunks other than intertoll.
3. Peg count of calls served by incoming and outgoing link frames, marker peg count, trunk block connector peg count, marker through traffic peg count, marker traffic separation per count, marker card read peg count, clock circuit pulses, reorder system overload announcement, local call intercept, blank code, no circuit trunk, group peg count, reorder trunk time alarms, marker trunk group peg count, sender peg count, decoder through traffic peg count, decoder separation peg count, decoder peg count, decoder pretranslation peg count, outgoing trunk group peg count, ringdown trunk peg count, card translator peg count, and various CAMA peg counts.
4. Sender link delay registration: Time alarm if two delay registrations are received within 28 to 56 seconds.
5. Group busy time duration registration: for common trunks, terminal trunks and via trunks one-way incoming, one-way outgoing, and two-way trunks, and for senders.
6. Usage registers: Group cycle and detector usage registrations associated with the traffic usage recorder circuit.

7. Load measurement: This circuit is arranged to record the traffic load on the individual incoming and outgoing link frames, the total traffic load on incoming link groups, and the traffic load on the sender groups.
8. Multiple plant registers: A multiple appearance of the first and second trial marker and decoder registers and the stuck sender registers from the maintenance center.

7. Traffic Supervisory Rack

The traffic supervisory rack is used in the operating room to assist the chief operator in estimating the delay that will be encountered in handling calls on any trunk group during heavy traffic periods; to provide a means to put that trunk group on a specific "delay quotation" basis of operating procedure; and to provide means of denying access to trunk groups for alternate route traffic. The traffic supervisory rack includes the following equipment: Sender Group Busy Lamps; Overflow Lamps; Delay Quotation Jacks for Overflow Trunks; Delay Quotation Trunk Patching Jacks; Alternate Route Traffic Control Keys and Lamps.

8. Traffic Usage Recorder

The traffic usage recorder is used by the traffic department for measuring the usage of the numerous circuits in the 4A Toll Office. This information is necessary for initial planning, for engineering quantity and arrangement of specific components, and for assignment of lines and trunks for a balanced system.

The traffic usage recorder is designed to measure usage directly in units of CCS (100 call seconds). At the end of any period of time the average traffic load carried by a group of circuits can be determined by taking account of the number of scans made and the total number of busies encountered. If the scan rate is set at 36 per hour, the accumulated number of busies at the end of an hour will indicate the group traffic load directly in terms of CCS per hour. Therefore the traffic usage recorder has a scan rate of 36 per hour with a corresponding scan interval of 100 seconds.

**B. MAINTENANCE EQUIPMENT**

**1. Automatic Outgoing Toll Connecting Trunk Test**

The automatic outgoing toll connecting trunk test (AOCT) frame provides for the selection of certain outgoing toll connecting trunks on the outgoing link frame and if they are idle, tests them for their principal features. All trunks which have access to local central office type test lines or on which a busy line flashing test can be made, and certain miscellaneous nonoperator type trunks are tested automatically. All trunks selected can be tested manually. This circuit appears on the incoming link frame in a manner similar to an incoming trunk, and by means of the test connector, will direct a marker to establish a connection through the incoming and outgoing links to the trunk to be tested. After determining that the trunk is idle, it makes it busy, and by means of a code passed to the common control equipment, directs the marker to test the particular trunk block terminals associated with the test circuit.

**2. Automatic Outgoing Intertoll Trunk Test**

The automatic outgoing intertoll trunk test (AOIT) frame is used to make operational circuit tests on outgoing intertoll trunks and the outward path of 2-way intertoll trunks to other toll offices. The tests are made through the regular switching train and are performed manually or automatically depending on whether or not the trunks can be terminated in an intertoll trunk test line at the far end. This circuit appears on the incoming link frame similar to an incoming trunk, and by means of a test connector will direct a marker to establish a connection through the incoming and outgoing links to the trunk to be tested. After determining that the trunk is idle, the test circuit makes it busy, and by means of a code passed to the common control equipment, directs the marker to test the particular trunk block terminals associated with the test circuit.

### 3. Incoming Sender and Register Test

The incoming sender and register test frame provides a means for the routine testing of all incoming sender (CAMA and NONCAMA), and CAMA transverters on an automatic basis. Also, individual equipments may be tested on a single or repeat test basis. The sender is seized by the test frame and selected codes are transmitted to it on either a multifrequency or a dial pulse basis. The output of the sender is then automatically checked against the input. Lamps are provided to indicate the progress of the tests and to indicate any failure of the sender on specific tests.

On automatic routine tests, the test frame automatically progresses from one sender to another until all of the incoming senders in the office have been tested, or, on certain tests, until all of the senders of a class, that is, dial, multifrequency, or CAMA have been tested. If trouble is encountered, the test frame stops and an alarm is operated. Various combinations of input and output conditions are checked, many on a marginal basis. The frame is equipped with a full keyset and a number of lever type keys for establishing the various test conditions.

### 4. Manual Outgoing Trunk Test Frame

This test frame (MTCT) provides a means of testing the toll completing trunks in the 4A toll office. The trunk test jacks are arranged so that this test circuit tests directly into the tip and ring leads of the cable to the distant office. It does not test the outgoing trunk relay equipment except to determine whether the trunk is idle. Provisions are made for directing a call over various types of trunks to a test line in the distant office, using a straightforward operation, revertive panel call indicator, multifrequency dial, and step-by-step pulsing. In conjunction with the test line at the distant end this circuit tests that the trunk is capable of reaching a particular destination code or number and that the ringing or signaling circuit as well as the supervision is functioning satisfactorily. This

circuit is also used to facilitate transmission testing of the trunk by providing rapid means of directing the trunk to a transmission test line in the distant office.

5. Test and Make Busy Frame

This test frame includes the test and make busy jacks of the outgoing trunks to be tested. Common jacks associated with the MTCT test circuit are also provided in this test frame. These common jacks are so located that they can be readily patched by means of cords to any one of the test and make busy jack circuits. In the 4A toll office, the test and make busy jacks are always cabled to the distributing frame for cross-connection to the associated outgoing trunk.

6. Outgoing Sender Test Frame

This frame has the same general functions as the incoming sender and register test frame, that is, automatic progression over the outgoing senders, or individual circuit testing, comparison of input with output information, indicating lamps, etc.

7. Sender Make Busy Frame

This frame provides for a central location for the maintenance of senders and incoming registers (used in CAMA application). This frame through the use of make busy jacks permits the removal of any defective sender from service. Associated with each jack is a stuck sender lamp and a priming jack. When a sender becomes stuck, its corresponding SS lamp will light and a minor audible and visual alarm will be brought in. The release of the stuck sender is made by the insertion of a make busy plug into its associated priming jack. A plug inserted into the MB jack of a stuck incoming or CAMA sender will cause the sender to be connected to the trouble recorder to record the number of the incoming trunk, whereas the insertion of a plug into the MB jack of a stuck outgoing sender will light a lamp indicating the sender link frame through which the sender is connected.

Associated with each incoming register is a priming jack and a stuck incoming register lamp. When an incoming register becomes stuck, its corresponding SP lamp will light. An incoming register is made busy by inserting an MB plug into the priming jack. The release of an incoming register is made by the insertion of a plug into the priming jack.

#### 8. Trouble Recorder

The trouble recorder frame consists of a trouble recorder, a decoder marker test circuit, a link controller test circuit, and a translator conditioning circuit all of which function more or less independently. The trouble recorder is called in by the link controller, decoder, or marker to make a punched card record of the information set up in the common control circuits at the time a call encounters trouble. The two test circuits are used to set up test calls on their respective common control circuits. A remote control feature permits the start and release of the test call at the location of the common control frame. The translator conditioning circuit is used to prepare any of the translators for addition or removal of cards or for the removal of the selector unit of the translator. Make busy jacks are provided for busying translators, decoders, decoder connectors, markers, link controllers, and controller connectors. In addition, traffic condition lamps are provided for the above frames and for the incoming, outgoing, and block relay frames. Jacks are also provided for putting the emergency translator in service in place of any other translator.

Card records may be originated by various circuits in the office, each of which has access to the trouble recorder circuit with preference in the following order: Decoders; Intertoll Markers; Toll Completing Markers; Link Controllers; Decoder Marker Test Circuit; Link Controller Test Circuit; Position Link and Controller Circuit; Register Link Alarm Circuit; Master Timer; AMA Records and Transverters.



When either of the two test circuits finds a trouble recorder busy on a service call, it will wait until the trouble recorder becomes available. The common control circuits, however, will not wait if they find the trouble recorder busy, but will lock in a lost record lamp in the trouble recorder frame and then release.

Tests of decoders, markers, and certain associated circuits, such as card translators and trunk class translators (CAMA) may be made from the trouble recorder frame. In all cases, a decoder is selected for use in the test and the test circuit primes this decoder with test call information similar to that which it would normally receive through a sender. Arrangements are provided for forcing the decoder to select a particular marker in a test call or allowing it to select a marker on a service basis.

Tests of link controllers may be made from the trouble recorder frame using the first link controller connector of each group to cut through test leads. The test circuit furnishes all of the information that the controller would receive through the sender link. The controller goes through all of its functions, including the selection of a simulated sender in the test circuit.

In-use lamps and alternate route lamps are concentrated in one portion of the trouble recorder frame and make busy jacks are concentrated in another part of the frame.

#### 9. Trouble Tracing Selector

In the 4A toll office there are incoming tandem trunks which have access, through the crossbar switching equipment, to any one of a number of outgoing intertoll trunks. When a trouble is reported on one of these connections only the identity of the incoming tandem trunk is known to the reporting operator. Since, for trouble location, it is also essential to know the identity of the particular outgoing toll trunk involved in the connection, some means must be provided to enable the test board attendant to identify this particular circuit. This is done by the provision of step-by-step trouble tracing

equipment. This equipment permits the test board attendant to connect, by dialing, to the reported incoming tandem trunk which is already connected through the toll crossbar equipment to the particular outgoing trunk involved. Once this connection from the test board is established, testing potential is applied over it to the outgoing toll trunk and the resulting operation of a lockout relay in that trunk lights an associated lamp in front of the test board attendant. Having thus identified the outgoing toll trunk, the trouble tracing selector equipment is released and the operator disconnects.

10. Auxiliary and Service Equipment  
Intertoll Trunk or CAMA Service Observing Frame

This circuit is used with service observing desks No. 7 or No. 12. It provides for observing on No. 4 type intertoll or incoming tandem trunk circuits in a No. 4A toll office with CAMA. The association of the particular trunk with the service observing trunk is effected by patching between the fifty connector sockets and the loop sockets for the associated trunks.

11. Emergency Alarm

The majority of 4A installations maintain an emergency alarm frame which includes the equipment associated with the automatic fire detection feature. This equipment functions with fusible fire detection wire to sound alarms when any break occurs in this series circuit setup.

12. Floor Alarm

Alarm features in addition to the trouble recorder previously described are provided in a manner similar to other crossbar systems. These alarms consist of fuse alarms, time alarms for the sender link and control circuits, markers, marker connectors, etc. Directing pilot lamps, namely frame aisle pilots, main aisle pilots, floor pilots and exit pilots are provided together with distinctive audible alarms. These lamps and signals are so arranged as to indicate audibly the severity of the alarm condition (major, minor, or power failure) and to show visually the type of failure

(fuse time alarm or test frame alarm) and the aisle location of the individual circuit alarm lamp. Arrangements are provided to extend the alarms from one floor to another.

### C. RECORDED ANNOUNCEMENT

The function of this equipment is to provide recorded announcements in the No. 4 Toll Switching System by means of magnetic tape recordings. The heart of the system is a recorder reproducer which consists of a motor driven drum surrounded by a magnetic band with six pairs of heads arranged to form six separate paths around the band. One of each pair of heads is arranged to record or to reproduce and the other to erase a message on the particular channel.

An announcement trunk circuit is provided in conjunction with each of the channels and is arranged to function with the particular switchboard or modified 601 type telephone set used to make the check recordings or to make emergency announcements should the recorder reproducer fail. The output end of the announcing trunk connects to several jacks at the traffic supervisory rack where each channel may be patched to groups of announcement connecting trunks for providing announcements.

Recording may be made on any channel of the system from the end positions of the toll dial (assistance) switchboard or where no switchboard is used, from a 619A type telephone set.

### 10.4 TYPICAL CALLS

Call through a No. 4A System - The following call is a single one requiring 3 digit translation and is switched to a system requiring MF pulsing.

The call arrives at the No. 4A office over an incoming trunk and leaves over an outgoing intertoll trunk. The incoming trunk may be selected by an outward operator or it may be seized at a distant automatic toll office. The procedure in this No. 4A office is the same in either case.

As shown in Figure 10-24, each incoming trunk has two major appearances in a No. 4A office, one on the incoming frame, used for the talking connection, and one on the sender link frame, used for passing information to the common control equipment.

As soon as the incoming trunk is seized it signals a sender link, (conn. 1) to connect it to an incoming sender for registering the incoming pulses. In order to make this connection the sender link frame through its connector signals a controller connector to seize an idle link controller (conn. 2). The link controller then tests for and seizes an idle incoming sender and closes the cross-points between this sender and the incoming trunk at the sender link frame (conn. 3). This completes the function of the link controller and controller connector and they release from the connection to serve other calls.

As soon as the incoming sender is attached it signals either for the outward operator to begin pulsing or, if the call is from a distant automatic toll office using senders, for the sender in that office to begin pulsing. When the incoming sender (using the pretranslation option) in this office has received and registered three digits it signals the decoder connector to seize an idle decoder (conn. 4). This decoder immediately connects to its home translator (conn. 5). Now the three code digits in the sender are transmitted through the decoder to the home translator and a card coded to correspond to these digits drops. This card contains information for switching the call with 3 digit translation.

The decoder reads the card and signals a marker connector to seize an idle marker (conn. 6). When a marker is seized the marker connector signals the decoder connector to connect the incoming sender to this marker (conn. 7 and 7a). This connection is necessary because the marker has to give certain information to the sender later after the decoder may have been released.

The marker obtains the locations of the outgoing trunks suitable of this call from the decoder and the dropped card. Guided by this information the marker selects an appropriate outgoing trunk through a trunk block connector (conn. 8). This trunk then registers its outgoing frame appearance in the marker.

The decoder and the card also tell the marker that the incoming sender should output on a multifrequency basis for this call, and whether the digits should be outputted as received, some digits skipped or converted. When the marker has received all this information it signals the decoder to release.

Now the marker proceeds to set up the talking path from the incoming trunk to the selected outgoing trunk. Through the outgoing frame connector, the marker gains access to the outgoing links and to the junctors (conn. 9). At the same time, the marker gains access to the incoming links through the incoming frame connector (conn. 9a). (The incoming trunk has already registered its incoming frame appearance to the marker over connections 1, 3, 4 and 7a.) The marker then tests the incoming and outgoing links and the junctors to find an idle channel between the incoming trunk and the outgoing trunk. It then closes the crosspoints to establish this channel (conn. 10).

Now the marker passes the outgoing information to the incoming sender and releases from the connection. The sender output pulses the digits through the sender link frame over the transmission path to the outgoing trunk and through to the called office; then the incoming sender and sender link frame release.

The connections in the transmission path remain until a disconnect signal is received. Then all the connections are released and the equipment returns to normal.

The time it takes the common control equipment to switch a call through a No. 4A office is so short that the operating time of each piece of apparatus is measured in milli-seconds. A typical marker operation, for example, with the high speed marker arrangements is about 375 ms.

#### 1. Calls Requiring Outgoing Senders

Outgoing senders are necessary for calls which are switched through a 4A office to offices which receive revertive or call indicator pulsing. This is because incoming senders can output pulse only MF and DP to distant offices.

The outgoing trunks that connect to such offices have an appearance on outgoing sender link frames. These frames are similar to incoming sender link frames.

A call going to an office that required PCI or revertive pulsing needs two senders: an incoming sender to register the call number and an outgoing sender to output pulse the called number.

When an outgoing trunk to an office requiring revertive or PCI pulsing is seized at the 4A office, it signals the outgoing sender link (conn. 11) that an outgoing sender is needed. The sender link seizes a link controller through a controller connector (conn. 12). The link controller tests for an idle sender and attaches it to the outgoing trunk (conn. 13); the link controller and connector then release and are free to serve other calls.

As soon as the outgoing sender is attached, a signal is sent to the incoming sender telling it to pulse the called digits into the outgoing sender. (Incoming senders pulse dc K-P into outgoing senders.) These digits are pulsed from the incoming sender through the incoming and outgoing frames, the outgoing trunk, the outgoing sender link and into the outgoing sender. The incoming sender and sender link then release from the connection. Now the connection consists of the transmission channel, the outgoing trunk, and the outgoing sender. The outgoing sender then outputpulses the called digits over the outgoing trunk and releases from the connection.

Figure 10-25 diagrams a typical intertoll connection through a crossbar toll office showing jack, signaling and switching equipment interconnections.

## 10.5 ELECTRONIC TRANSLATOR SYSTEM

### A. INTRODUCTION

With the volume of traffic switched through 4A/4M toll machines reaching higher levels each year, two aspects of the route translation - cost and flexibility - have become increasingly important. Continued use of the electromechanical card translator would exact major penalties in both of these respects. In addition, future network management arrangements would be seriously hampered. Of the choices available for replacement of the card translator, a system using solid state switching devices under stored program control has been chosen and designated the Electronic Translator System (ETS).

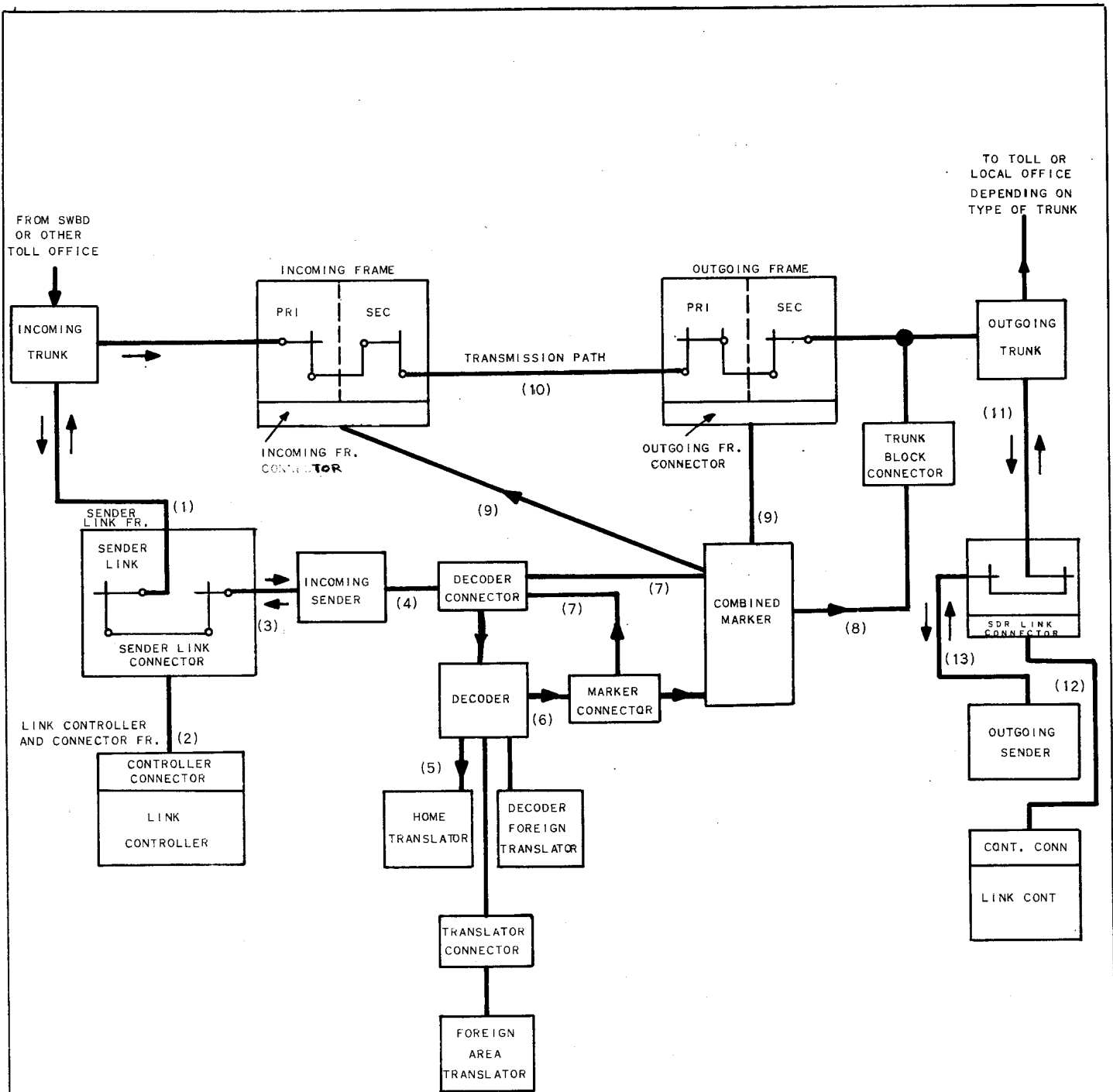

Figure 10-24 - Call Through A Combined Train Office

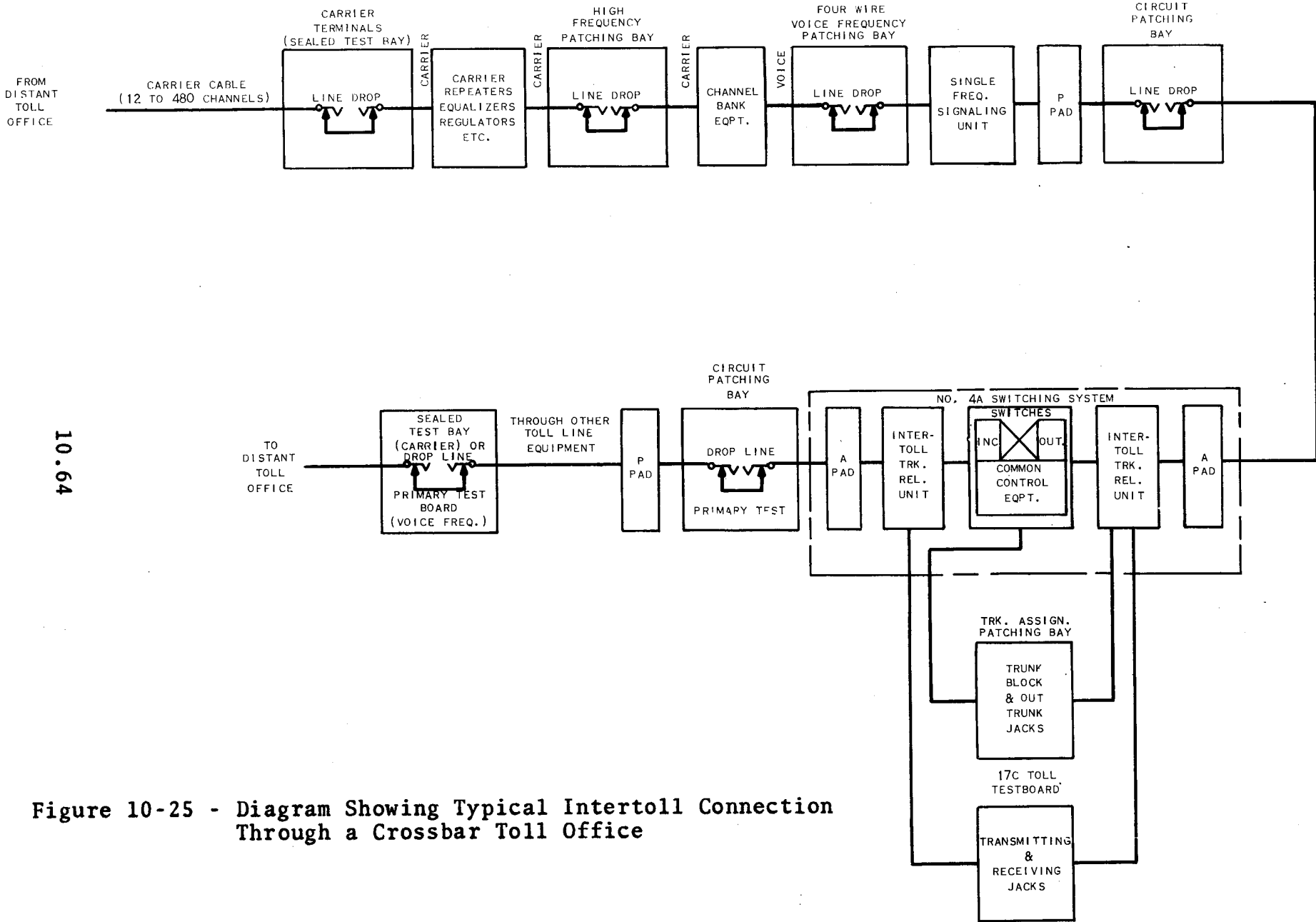

Figure 10-25 - Diagram Showing Typical Intertoll Connection Through a Crossbar Toll Office

10.64

CH. 10 - 4A TOLL SWITCHING SYSTEM



The new system will be capable of meeting, increased translation requirements resulting from growth of toll traffic and the introduction of new or changed services, such as overseas transit dialing, private network arrangements, and the new numbering plan. Electronic translation provides a greatly expanded supply of incoming trunk class marks for use in conjunction with address digits and other control inputs, and allows electrical alterability of route translation, to expedite emergency changes and facilitate network management procedures.

#### B. PRINCIPLES OF SYSTEM OPERATION

The basic component of the ETS arrangement is a Common Systems Stored Program Control (SPC) No. 1A which has been developed concurrently with the Traffic Service Position System (TSPS) No. 1A that will employ the 100B T.S.P. with electronic switching to improve operator assistance facilities.

The solid-state SPC is a fully-duplicated, stored program, digital control system as is the Central Control with associated Program and Call Stores used in the No. 1 ESS. The SPC differs from the ESS Central Control in that it employs a single-type of bulk memory using the new Piggy-back Twister (PBT) module for both program and data storage.

The SPC operates under control of a program of instructions (the soft-ware) which is a set of 40 bit words stored in the memory (Store). The software for each SPC application will include common programs for operating and maintaining the SPC itself. The SPC Processor fetches instructions sequentially from the Store and executes them one at a time. In normal operation, the two Processors will operate in parallel to execute identical instructions fetched independently from the duplicated Stores. One of the Processors assumes active control of input or output and of system activities. High speed matching of information between the two Processors will provide the major means of trouble detection within the SPC.

General input to the SPC is through adapted No. 1 ESS Master Scanners (MS) which are duplicated and contain unduplicated ferrer sensors as scan points to monitor the presence of current in connecting circuits and convert information from electromechanical to electronic form.

General output of the SPC is through adapted No. 1 ESS Signal Distributors (SD) and Central Pulse Distributors (CPD) which are duplicated. The SD responds to high-speed signals from the Processor to operate or release magnetically latching wire spring relays. The CPD responds by providing pulses to control solid-state flip-flops for its major function of performing address decoding for units such as the MS and SD.

A Master Control Center provides controls, alarms displays, and associated Program Tape (PT) and Teletype-writer (TTY) units which are necessary to maintain the SPC and peripheral electronic equipment. TTY is also used by the SPC to supplement alarm and status information for maintenance personnel and may be duplicated at a remote location for extended control purposes.

The interface between the SPC and the 4A/4M Crossbar equipment requires several peripheral circuits of both electromechanical and electronic types as shown in the 4A/4M Electronic Translator System diagram of Figure 10-26.

The Decoder Channel Circuit (DCH), consisting of wire-spring relays, provides sender access from Decoder Connectors to the SPC for the dialed code digits and controls selection of an Intertoll or Toll Completing Marker through Marker Connectors by instructions from the SPC. The Decoder Channel also verifies the sender-marker connection and the registration of routing information which the marker receives from the SPC through the marker connector and two peripheral electronic circuits: The Distributor Register (DR) and the Peripheral Function Translator (PFT).

The Peripheral Scanner (PSC) uses ferrod sensors to monitor status, detect bids, and to read input information required by the SPC for call handling. The major circuits scanned by the SPC are the Decoder Channel, Sender Link Controller and Group Busy Relays.

A new Power Distributing Frame (PD) supplied by a 111A Power Plant provides power for all peripheral and SPC circuits.

### C. MODIFICATION OF EXISTING 4A/4M SYSTEMS

The major 4A/4M circuits requiring modification are: Decoder-Marker Test and Trouble Recorder, Marker and Decoder Connectors, Sender Link and Connector, Sender Link

Controller, Controller Connector, Incoming Sender and Register Test, Group Busy Relays, and the Marker. The Marker modification is relatively minor and consists mainly of the removal of relays. The Incoming Senders and Trunks do not require any modification.

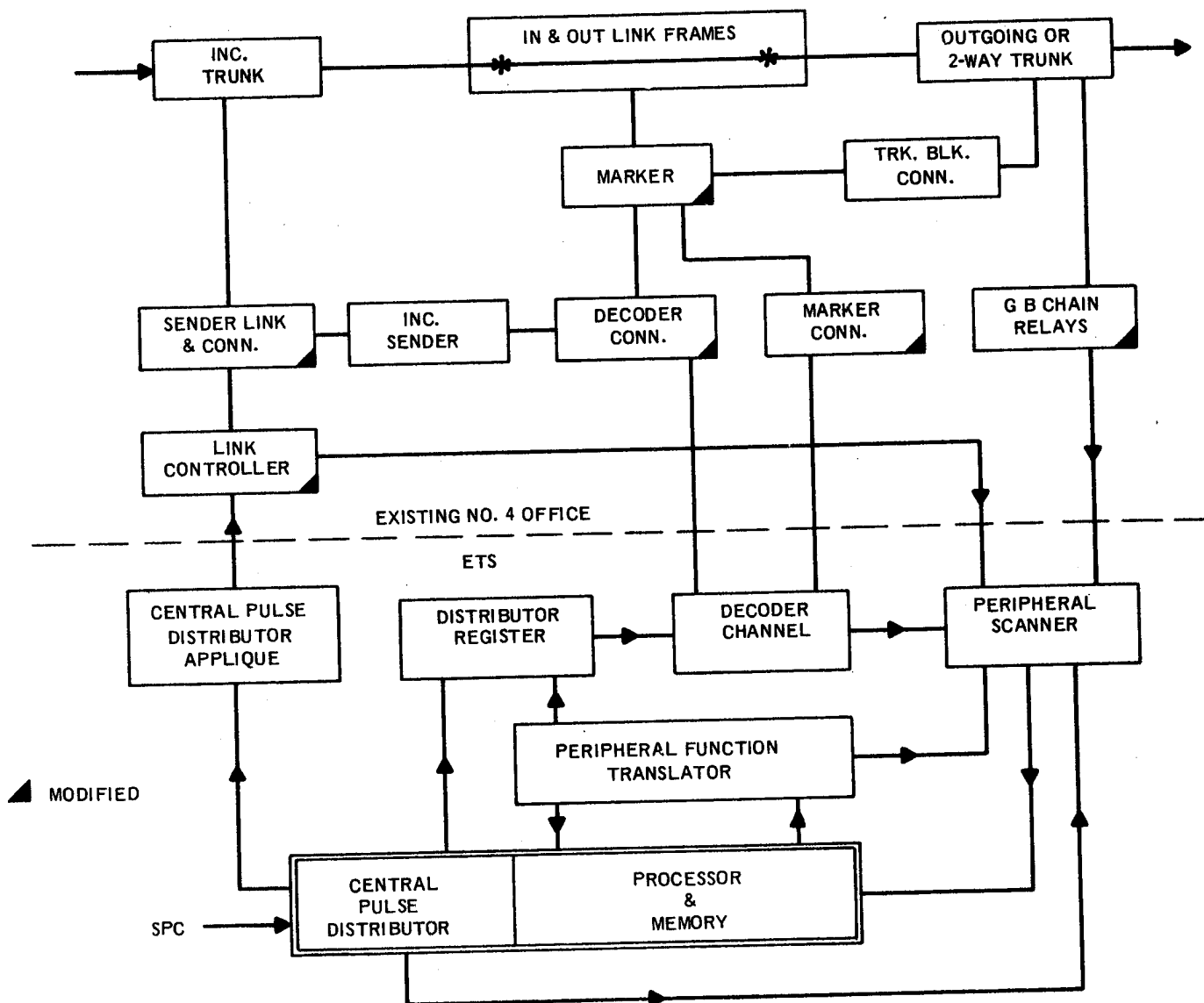

Figure 10-26 - 4A/4M Electronic Translator System

#### D. BASIC PROGRAMMING CONCEPTS OF THE SPC

The functions to be performed by the SPC and the peripheral units are specified by programs which are stored in the PBT memory. The memory stores both programmed instructions and data. All instructions, and some data, are stored on a relatively permanent basis and are changed as dictated by changes in procedures or service. Some of the data is relatively temporary in nature, since it may be entered into memory, modified, and erased during the processing of a call. The programmed instructions provide the intelligence necessary to instruct the Processor in the many functions required of it under any of the many call situations the SPC may encounter. Instructions can also be referred to as orders or commands.

Data differs from instructions in that it consists of information such as results computation, records of dialed digits, and information as may be required at some time for processing.

The Processor, according to the instructions in the Store, either directly or indirectly controls the operation of every circuit in the system. All commands specifying an operation in peripheral circuits originate within the Processor and all answers signifying the state of circuit points within the system are returned to SPC. Certain instructions result in actions which are entirely confined to the SPC. For example, an instruction or series of instructions may command the Processor to perform logical or arithmetic operations on data currently contained within the SPC. Other instructions may cause the SPC to command a peripheral circuit to perform an operation which results in an answer being transmitted back to the SPC by way of a scanner.

The SPC instructions or orders are of three main classifications:

1. Input - Output Orders: There is one type of input order which calls for scanning a set of as many as 20 input connections and one output order which commands distribution to the peripheral units.
2. General Purpose Orders: There are twelve basic orders that provide the necessary arithmetic and logic operations of the Processor. The arithmetic operations include: subtraction, comparison, shifting, and rotation; and the logic operations are: And, Or, Exclusive Or, and Complement.

3. Maintenance and Miscellaneous Orders: Special orders are provided to implement the necessary fault recognition, diagnostic, and routine test programs.

#### Application Programming

The application of the SPC for use with ETS requires a program of approximately 7300 words.

The stages of this ETS program consist of control and administration, Sender Link Controller, Decoder Channel, and maintenance programs.

This program will be in common to every ETS installation and is adapted to the local conditions by the data provided by the operating company.

Input and Output Message Manuals are provided to allow communication with SPC from the Master Control Center Teletypewriter.