

**“SLC”-96 SUBSCRIBER LOOP CARRIER SYSTEM
REMOTE POWER FEED TERMINAL (RPFT)
DESCRIPTION, INSTALLATION, AND MAINTENANCE**

CONTENTS	PAGE	CONTENTS	PAGE
1. GENERAL	1	Chart 4—Final Test	22
2. DESCRIPTION	2	Chart 5—Installation of Subsequent SLC-96 Systems With an Existing RPFT	23
A. 6A Power Panel	2	6. MAINTENANCE	24
B. WN15 Line Feed Converter (LFC)	2	1. GENERAL	
C. 3A Battery Charger	2	1.01 This section provides description, installation, and maintenance information for the SLC-96 subscriber loop carrier system remote power feed terminal (RPFT).	
D. 128A Apparatus Mounting and Batter- ies	2	1.02 Whenever this section is reissued, the reason for reissue will be given in this paragraph.	
E. Cabinets and Mounting	7	1.03 The remote power feed terminal is used to ex- tend the range of SLC-96 systems using low power (60 mA) T1 lines, in addition to central office (CO) and possibly remote terminal (RT) powering. Each RPFT is capable of powering up to 25 T1 digital lines. The allowable number of lines that may be ac- commodated in a given installation may be limited by battery reserve considerations.	
3. POWERING OPTION APPLICATIONS	7	1.04 Each RPFT consists of a battery charger, bat- teries, DC-to-DC converters and alarm cir- cuitry. Each DC-to-DC converter produces 60 mA output to power 238-type line repeaters as part of a low power T1 line. The RPFT hardware has been de- signed for both cabinet and rack mounting to allow flexibility in its use.	
A. Option Y (Maximum ±135 Volts dc Output)	10	1.05 The remote power feed is usually located on or near the carrier route so that maintenance access is possible. Engineering rules for determining the location are contained in Section 915-710-110.	
B. Option Z (Maximum -135 Volts dc Out- put)	11		
C. Simplex Options	11		
4. APPARATUS	14		
5. INSTALLATION	15		
Chart 1—Installation of KS-21906, L4 Batteries in the 37A Cabinet	15		
Chart 2—Installation of KS-21906, L4 Batteries in the AT-8908M Cabinet or the Frame-Mounted RPFT	16		
Chart 3—Initial Test	17		

*Trademark of Western Electric.

NOTICE

Not for use or disclosure outside the
Bell System except under written agreement

2. DESCRIPTION

2.01 The RPFT has been designed to use SLC-96 components, wherever possible. These include SLC-96 cabinets, mini-hut, battery charger, and back-up batteries.

A. 6A Power Panel

2.02 The 6A power panel (Fig. 1) is made up of two standard SLC-96 equipment shelves and includes a pair of protection blocks at the top. The total height of the 6A power panel is approximately 13 inches.

2.03 The 6A power panel accepts the WN15 line feed converter (LFC) circuit pack as a plug-in. As many as 25 LFC circuit packs may be plugged into the 6A power panel thereby providing a match to the 475-type, and the 818, 819-type repeater cases which accommodate up to 25 repeaters.

2.04 The right side of both shelves contain fuses for each LFC position and for an alarm relay circuit. A terminal strip for wiring in external alarms, such as a door alarm, is located on the right side of the first (lower) shelf and an order wire block is located on the second (upper) shelf adjacent to the fuse blocks. The first shelf accommodates the first 13 LFC plug-ins and the second shelf accommodates the remaining 12 LFC plug-ins.

2.05 The 6A power panel provides an alarm relay closure when an alarm condition is detected from the 3A battery charger, from the external alarm terminal (door alarms), or when the alarm fuse (FA) blows. This alarm closure can be accessed on a protected pair to indicate a RPFT alarm. A cable pair is needed to send the alarm to the CO or RT. If a LFC fuse blows, no alarm is indicated.

B. WN15 Line Feed Converter (LFC)

2.06 The WN15 LFC (Fig. 2) is a medium width (one inch) plug-in circuit pack. The LFC contains a constant current dc-to-dc converter circuit for powering low power (60 mA) T1-type line repeaters. The plug-in also contains secondary lightning protection and the power insertion transformers to simplex the dc current onto the T1-line pairs.

2.07 The WN15 LFC accepts a nominal -48 Vdc at its input and will develop a constant 60 mA output at voltage levels which may be as high as ±135 Vdc (Y option). The output voltage developed will be uniformly positive and negative relative to ground within its maximum limits. As an option, only the negative voltage (-135 Vdc maximum) may be supplied to the output where it is important to minimize possible cable corrosion (Z option). The LFC inserts 110 ohms of resistance in the dc path for circuit protection and current measurement.

C. 3A Battery Charger

2.08 The 3A battery charger (Fig. 3) provides power for the WN15 LFC circuit packs in the RPFT. The input source is 120 Vac and the output voltage is signal grade -48 Vdc. The battery charger also provides -64 Vdc to charge standby batteries.

2.09 Controlled current, two-rate charging is provided by the 3A battery charger. The unit contains a battery charger control circuit pack (YL-1B) which senses loss of commercial ac, switches the batteries to load, and provides an alarm contact closure to the 6A power panel. After restoration of commercial ac, the high rate charge will return full capacity to the standby batteries within 24 hours. The low rate float current will maintain the batteries at full capacity for indefinite periods.

D. 128A Apparatus Mounting and Batteries

2.10 The 128A apparatus mounting (Fig. 4) holds a battery string that supplies 25 ampere-hours of reserve power at a nominal 48 Vdc. The battery string is made up of four sealed, lead-acid 12 Vdc batteries. Each battery contains six series-connected 2 volt cells. The apparatus mounting includes an ac powered, thermostatically controlled heater to ensure output capacity during cold weather. This battery heater keeps the batteries above 25°F in outside ambients down to -40°F.

2.11 All RPFT configurations are allocated two 25 ampere hours (AH) battery strings for a total of 50 AH. Thus two 128A apparatus mountings, with batteries, are used in the frame-mounted and M-cabinet arrangement. The 37A cabinet has its own battery shelves and does not contain the 128A apparatus mountings.

DIGITAL LINES SIDE 1 IN					
1	5	9	13	17	21
2	6	10	14	18	22
3	7	11	15	19	23
4	8	12	16	20	24

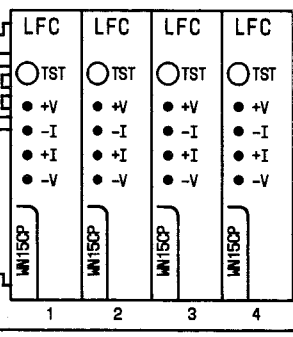
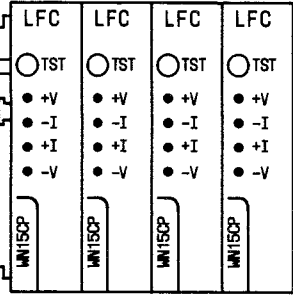
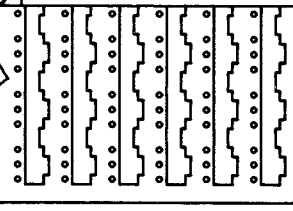
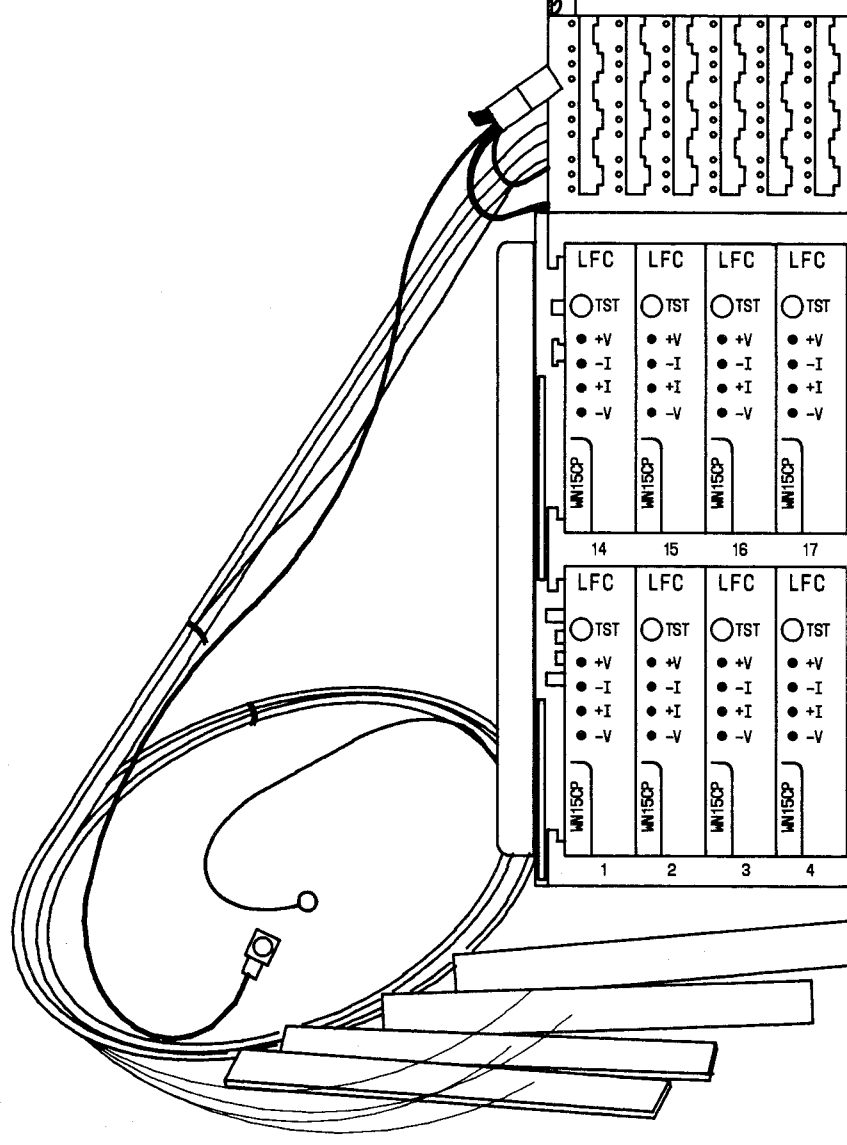

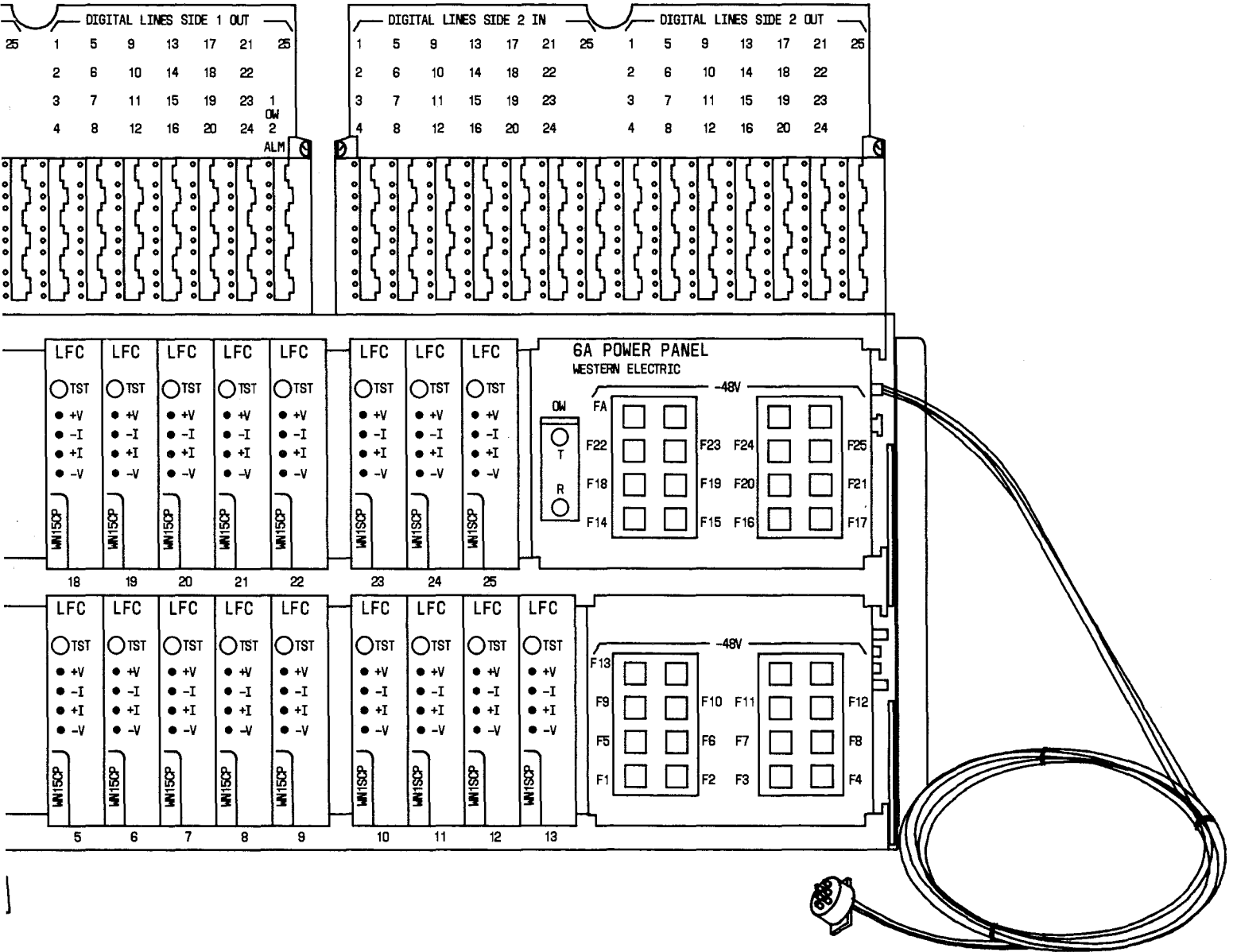

Fig. 1—6A Power Panel

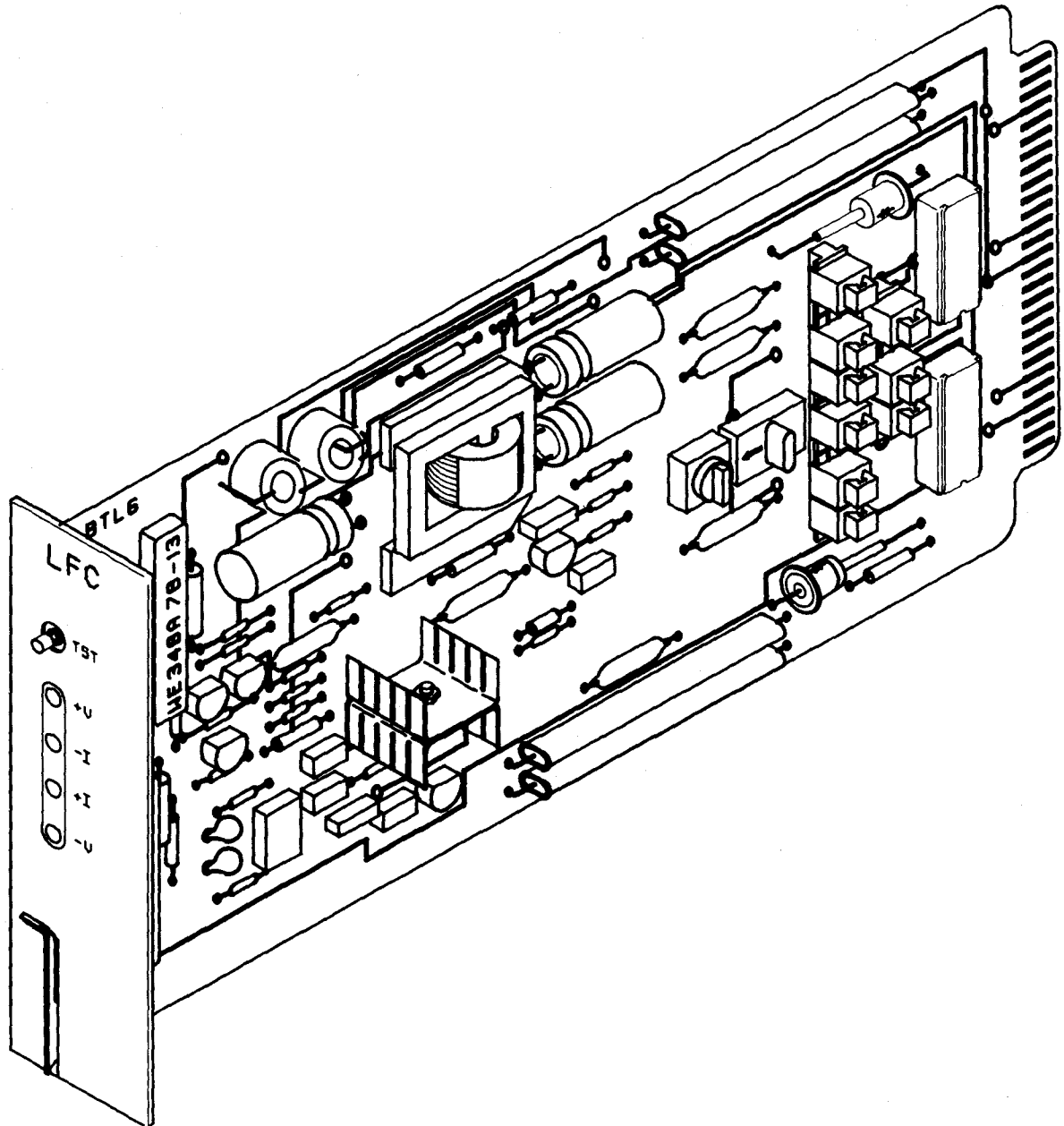

Fig. 2—WN15 Line Feed Converter (LFC) Circuit Pack



Fig. 3—3A Battery Charger

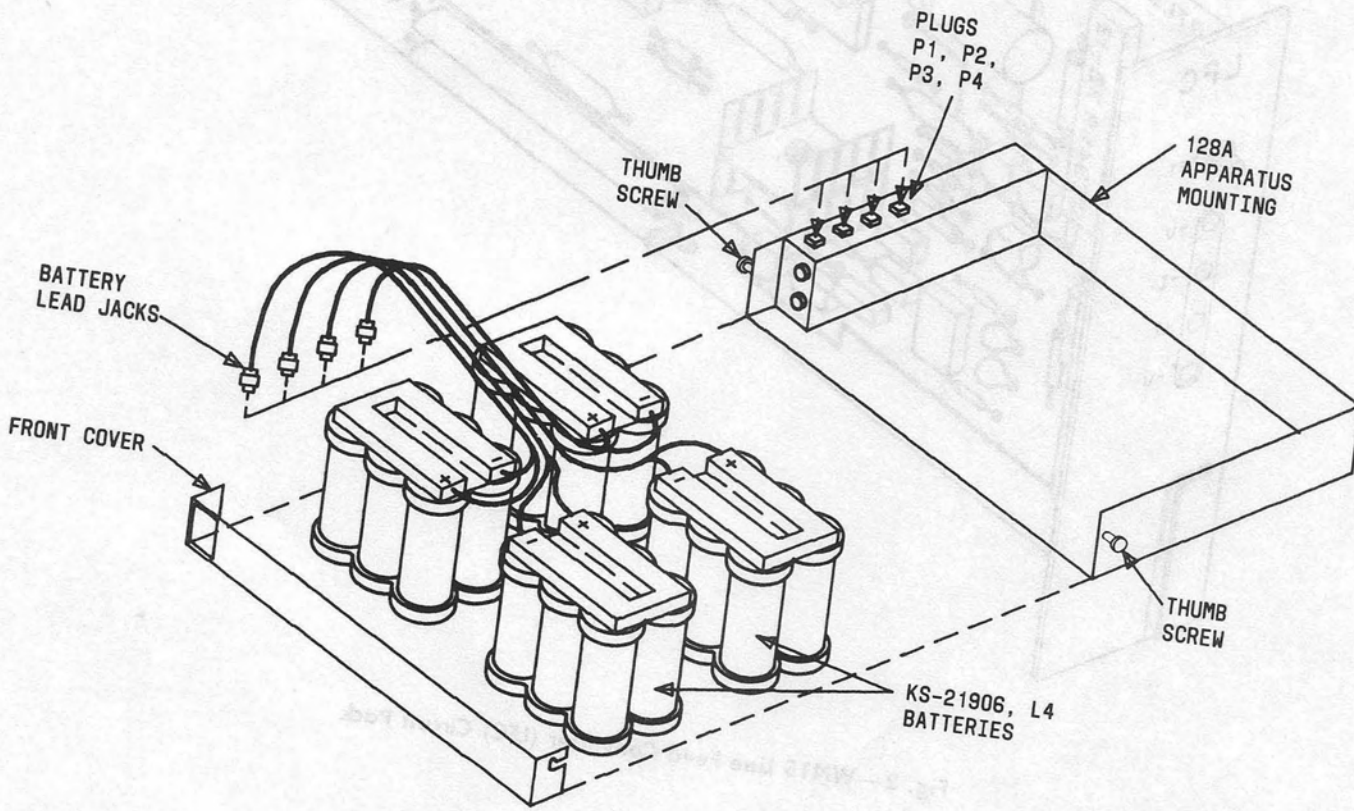

Fig. 4—128A Apparatus Mounting

E. Cabinets and Mounting

2.12 The RPFT can be assembled in a 7-foot frame (one or two RPFT systems per 7-foot frame), in an AT-8908M cabinet (excluding fan assembly), or it can be purchased as a completed assembly from the factory as the 37A cabinet. These mounting arrangements are shown in Fig. 5, 6, and 7.

3. POWERING OPTION APPLICATIONS

3.01 Although the RPFT can hold up to 25 line feed converters (LFC), the allowable number that may be accommodated in a given installation may be limited by battery reserve considerations. This results from a requirement to provide a minimum terminal operation of eight hours during a prolonged ac

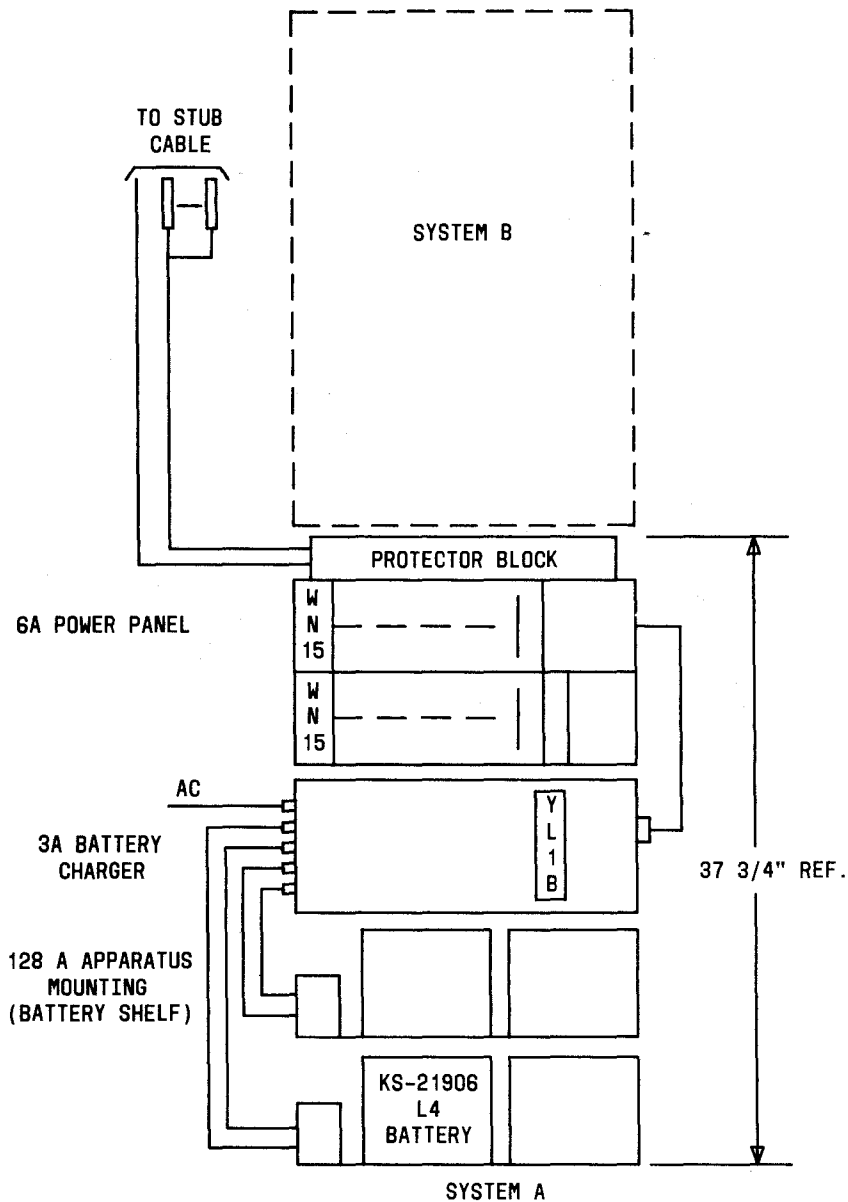

Fig. 5—Remote Power Feed Terminal (RPFT)—Typical Frame Arrangement

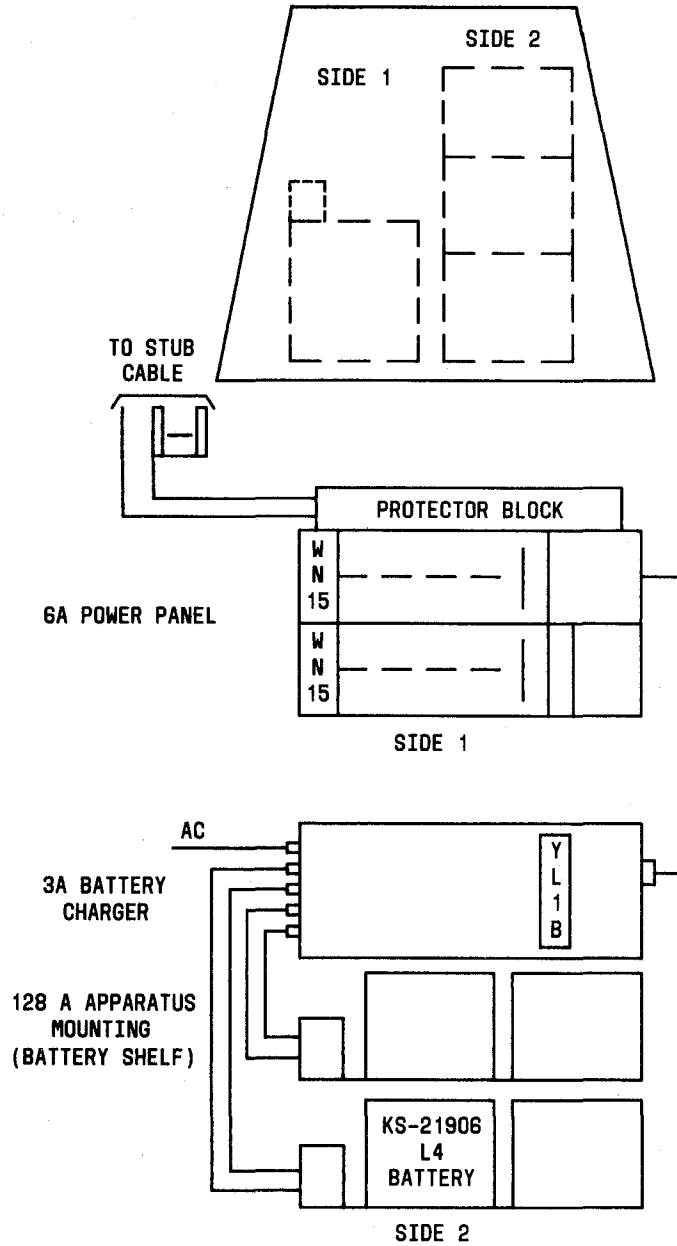

Fig. 6—Remote Power Feed Terminal (RPFT)—Typical AT-8908M Cabinet Arrangement

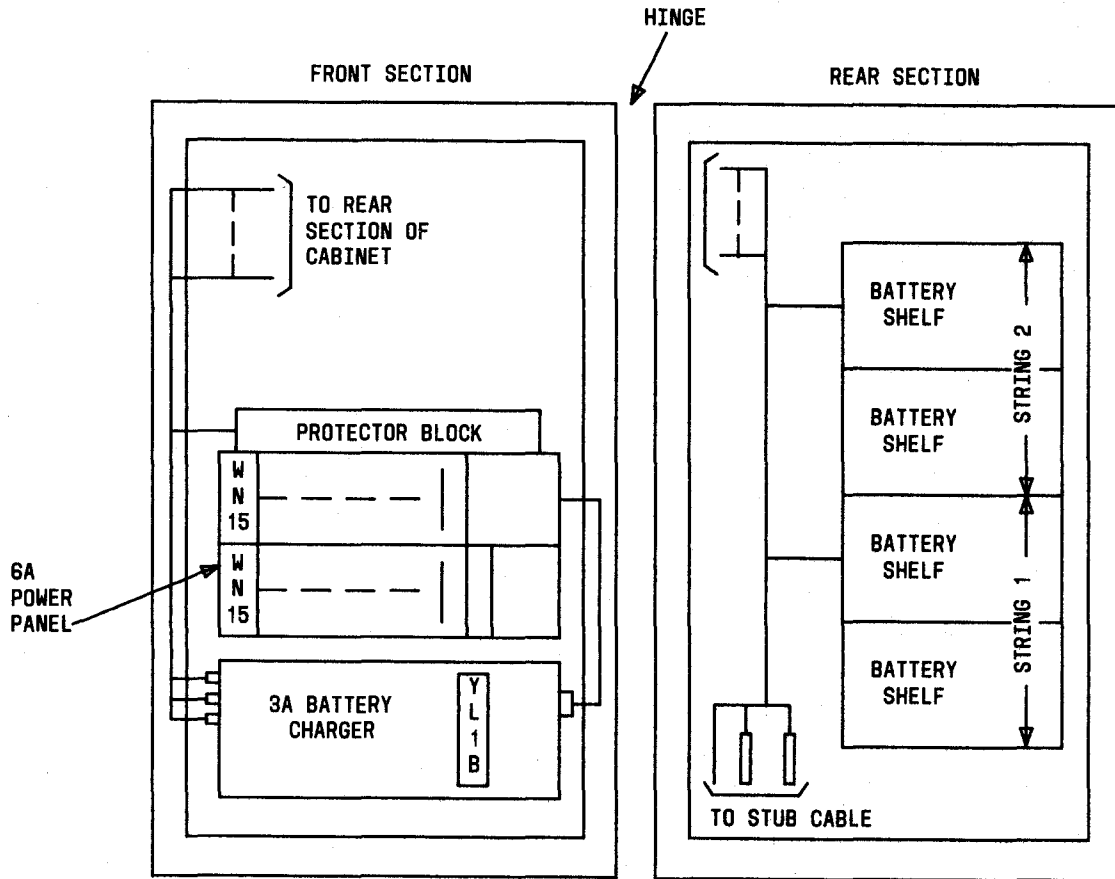

Fig. 7—Remote Power Feed Terminal (RPFT)—Typical 37A Cabinet Arrangement

power outage. Another factor affecting the allowable number of LFC plug-ins is the output voltage option selected. The LFC delivers a constant 60 mA line current at maximum output voltages which may be optionally set to ± 135 Vdc, or -135 Vdc only (option Y or Z respectively, Fig. 8).

3.02 The maximum number of LFC plug-ins that can be installed in a RPFT is a function of the simplex resistance of the repeatered line powering spans served by that RPFT. *The total span simplex resistance is the sum of all repeater resistances plus the simplex cable resistance.* The total resistance that can be driven from the RPFT while providing a minimum of 8-hour operation on batteries is expressed in the equation below.

$$[N_1 \times R_1] + [N_2 \times R_2] + \dots + [N_i \times R_i] < 48,000 \text{ ohms.}$$

N_1 = Number of WN15 converters powering a distance equivalent to simplex resistance R_1 .

This equation provides for branches in the digital line paths as shown in Fig. 9.

A. Option Y (Maximum ± 135 Volts dc Output)

3.03 When using the full range, Y option, on the line feed converters of ± 135 Vdc (270 volts), the maximum powering distance on 22 gauge is approximately 100 kft. To account for effects of ac power line induction on the WN15, the maximum simplex resistance that can be driven per converter for option Y is limited to a maximum of **3800 ohms**. The number of converters that may be supported at one time is subject to battery reserve limitations and is limited to 12 plug-ins when powering the maximum resistance of 3800 ohms. The number 12 is matched to the new 809-type apparatus case which can house a maximum of 12 line repeaters.

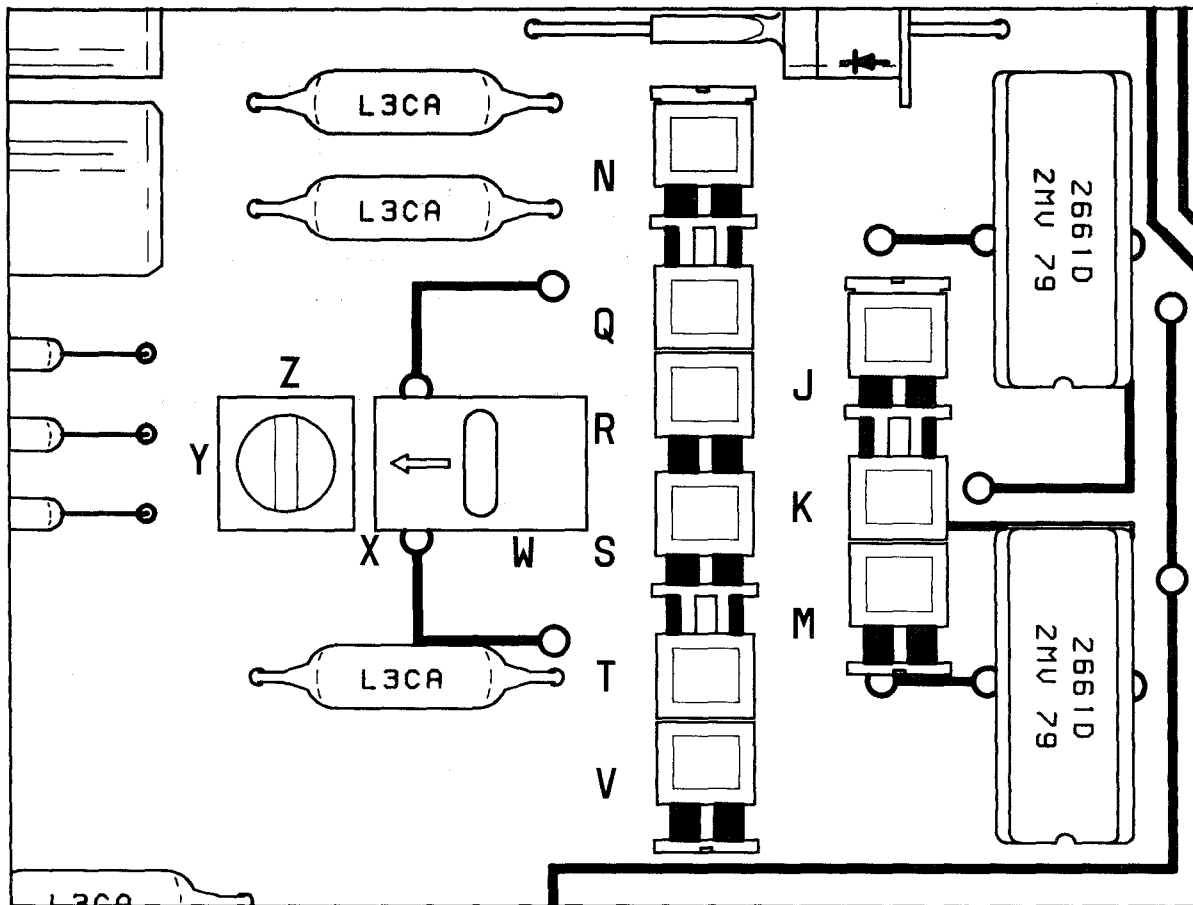

Fig. 8—WN15 LFC Circuit Pack—Option Switches and Plugs

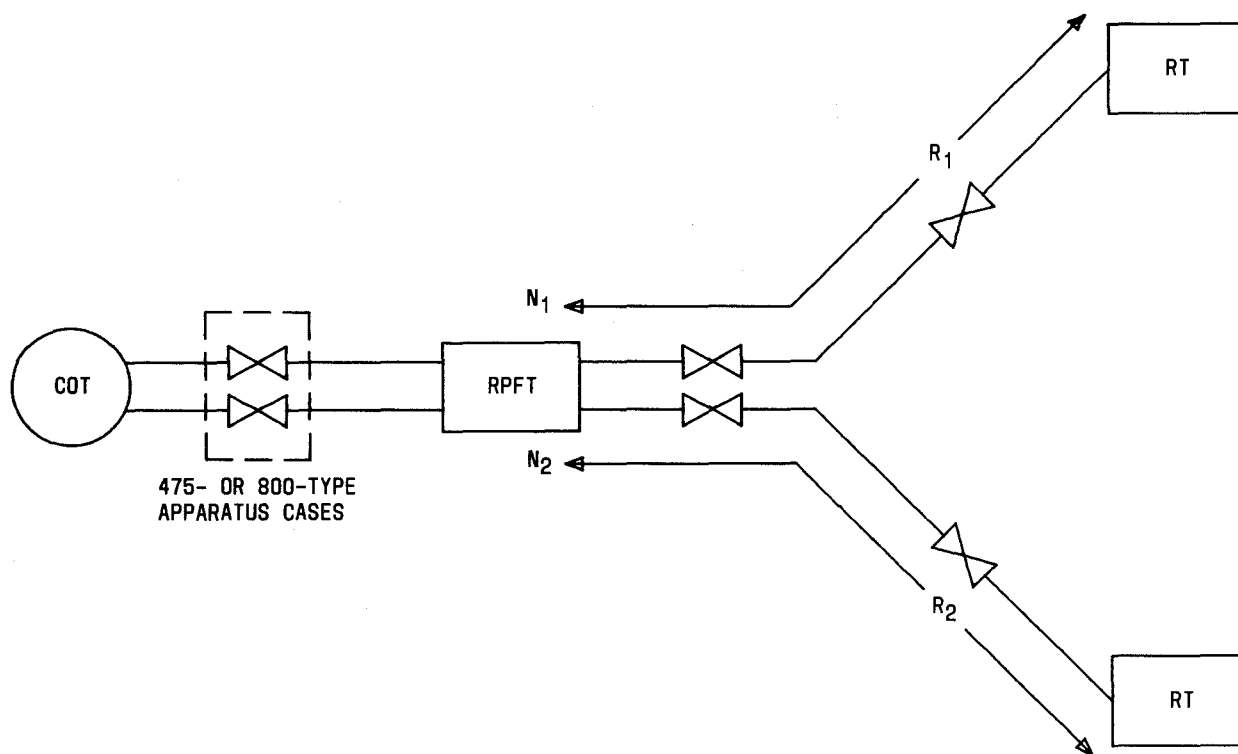

Fig. 9—Typical RPFT Arrangement With Digital Line Branch

B. Option Z (Maximum -135 Volts dc Output)

3.04 The Z option on the line feed converters limits the maximum output voltage to -135 Vdc and is used to minimize the possibility of corrosion where the use of positive voltage is prohibited. To account for effects of ac power line induction on the WN15, the maximum simplex resistance that can be driven per converter for option Z is limited to a maximum of **1900 ohms**. For option Z, 25 digital line spans may be powered to the maximum simplex resistance range of 1900 ohms. The number 25 was chosen so the RPFT is compatible with the 475-type and the 818, 819-type apparatus cases which hold up to 25 line repeaters each. When using the half range, Z option, the maximum powering distance is limited to approximately 50 kft on 22-gauge cable.

C. Simplex Options

3.05 The means to gain access to the simplex loop to insert power onto the digital line is via a pair of transformers with center-tapped primary and

secondary windings for each digital line. These transformers are part of the LFC plug-in along with the dc-to-dc converter. The output of the dc-to-dc converter and the center taps of the transformers may be connected in several different configurations depending on the application of the RPFT. These options may be selected via option plugs and a switch setting on the WN15 LFC plug-in (Fig. 8).

3.06 There are four basic simplex arrangements for the RPFT. A single converter plug-in may power toward the CO with the field side looped (Fig. 10 and 11). A single converter may power toward the field (RT) with the CO side looped (Fig. 12). A single converter may be spliced at some midpoint along a powering span, powering in both directions from the RPFT (Fig. 13). Finally, a pair of adjacent converter plug-ins may be assigned to a single digital line feeding two powering spans, one toward the CO, and one toward the RT (Fig. 14). In all cases, power looping repeaters should be used to isolate powering spans.

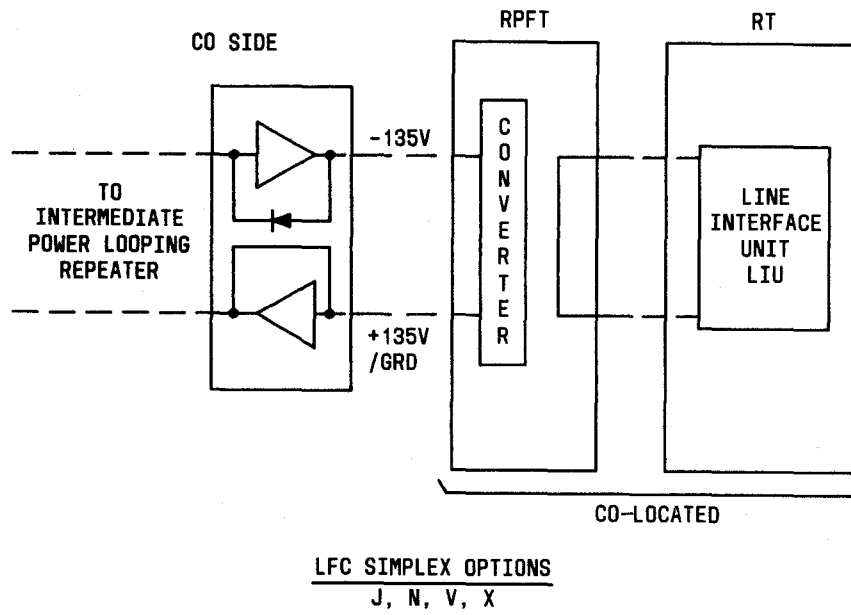

Fig. 10—Typical RPFT Powering Arrangement—LFC Powering Toward CO With RPFT at RT Site

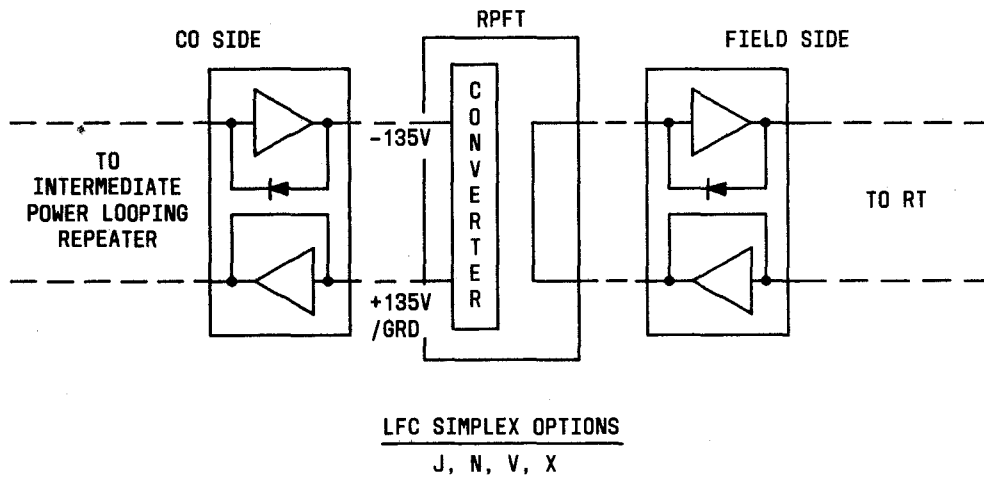

Fig. 11—Typical RPFT Powering Arrangement—LFC Powering Toward CO

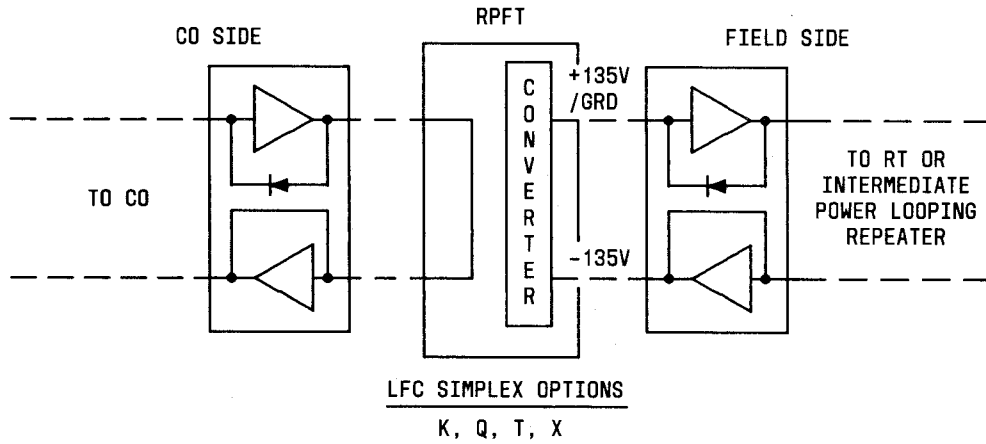

Fig. 12—Typical RPFT Powering Arrangement—LFC Powering Toward RT

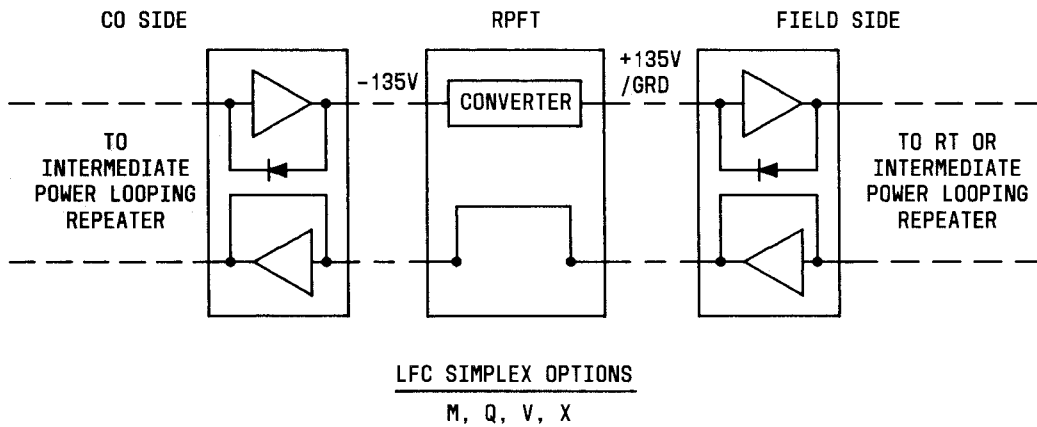

Fig. 13—Typical RPFT Powering Arrangement—LFC Powering Toward CO and RT

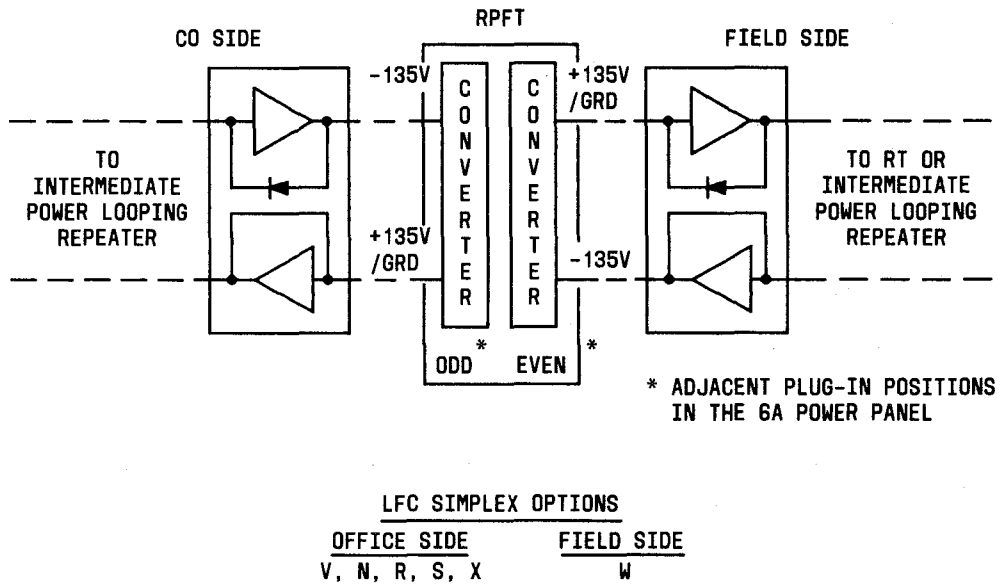

Fig. 14—Typical RPFT Powering Arrangement—Adjacent LFC Circuit Packs Powering Two Spans on a Single Digital Line

4. APPARATUS

4.01 The following apparatus is required for procedures outlined in this section.

1—KS-14510, L5 Volt-Ohm-Milliammeter (VOM) or equivalent (Section 100-520-101)

1—Special key, 840841324, for opening 37A cabinet

1—216-type tool, for opening AT-8908M cabinet

1—KS-21838 extractor tool, for setting option plugs.

5. INSTALLATION

CHART 1

INSTALLATION OF KS-21906, L4 BATTERIES IN
THE 37A CABINET

Danger 1: Exercise care when handling the KS-21906, L4 batteries. Excessive current flow will occur if a short is placed across the battery terminals resulting in equipment damage as well as possible personal injury. No attempt should be made to measure the battery voltage across the terminals.

Danger 2: AC voltage greater than 110 volts is present at AC PWR & AC HTR fuse holders on the 3A battery charger if ac power is applied.

STEP	PROCEDURE
1	Ensure that the ac power circuit breaker is off or that the ac power cord is disconnected from the 3A battery charger plug (P112).
2	Remove both +BATT(F1) and -BATT(F2) fuses (if installed) on the control box assembly.
3	Place batteries on the battery shelves (lower two shelves first) and dress the battery cables neatly.
4	Connect each battery lead jack to one of two plugs supplied to each shelf. Note: The four plugs supplied to the lower two shelves are labeled P1, P2, P3, and P4. The four plugs supplied to the upper two battery shelves are labeled P5, P6, P7, and P8.
5	Using a VOM conditioned to read dc volts, insert positive test lead in +BATT jack and negative test lead in -BATT jack on the control box assembly for the battery string being tested. Requirement: Meter indicates greater than 48.0 volts dc. Note: If batteries have been in storage for a long period of time, or ambient temperature is high, the battery string voltage may be slightly lower.
6	If battery string 2 has been installed in the top two shelves, go to Step 7. If not, remove both +BATT(F3) and -BATT(F4) fuses and repeat this procedure from Step 3 for battery string 2.
7	Remove VOM and install good fuses (15 amp) into the control box assembly +BATT and -BATT fuse holders for both battery strings.
8	When the requirements of this chart are met, proceed to Chart 3.

CHART 2

**INSTALLATION OF KS-21906, L4 BATTERIES
IN THE AT-8908M CABINET OR THE
FRAME-MOUNTED RPFT**

Danger 1: Exercise care when handling the KS-21906, L4 batteries. Excessive current flow will occur if a short is placed across the battery terminals resulting in equipment damage as well as possible personal injury. No attempt should be made to measure the battery voltage across the terminals.

Danger 2: AC voltage greater than 110 volts is present at AC PWR & AC HTR fuse holders on the 3A battery charger if ac power is applied.

STEP	PROCEDURE
1	Ensure that the ac power circuit breaker is off or that the ac power cord is disconnected from the 3A battery charger plug (P112).
2	On 128A apparatus mounting (Fig. 4), remove both +BAT and -BAT fuses (if installed).
3	Referring to Fig. 4, loosen two thumb screws on the sides of the 128A apparatus mounting and remove the front cover.
4	Install four KS-21906, L4 batteries on the shelf, orienting cables as shown in Fig. 4.
5	Insert the four connecting jacks in plugs P1 through P4.
6	Reinstall the front cover and retighten the thumb screws.
7	Repeat Steps 2 through 6 for the second 128A apparatus mounting (second battery string).
8	Using a VOM conditioned to read dc volts, insert the positive test lead in +BAT jack and the negative test lead in -BAT jack on one of the 128A apparatus mountings.
	Requirement: Meter indicates greater than 48.0 volts dc.
	Note: If the batteries have been in storage for a long period of time, or ambient temperature is high, the battery string voltage may be slightly lower.
9	Repeat this procedure from Step 2 for the second battery string.
10	Remove VOM connections and install good fuses (15 amp) into the battery shelf +BAT and -BAT fuse holders on both battery shelves.
11	When the requirements of this chart are met, proceed to Chart 3.

CHART 3
INITIAL TEST

Danger: AC voltages greater than 110 volts is present at the AC PWR & AC HTR fuse holders on the 3A battery charger if ac power is applied.

STEP	PROCEDURE
1	If the RPFT is cabinet mounted, pull the door alarm plunger switches (one on the AT-8908M cabinet, two on the 37A cabinet) to the outer detent (no alarm) position.
2	Get a YL-1B circuit pack and install into the YL-1B slot on the 3A battery charger.
3	Install a good AC PWR fuse (15 amp) and a good AC HTR fuse (5 amp) in the 3A battery charger.
4	On the 6A power panel, install a good 70P (1/10 amp) fuse in the FA (fuse alarm) fuse holder.
5	Operate the ac power breaker to the ON position and/or insert the ac power cord into the 3A battery charger plug (112). Requirement: On the YL-1B circuit pack, HI lamp is lighted within 30 seconds. Note: If this requirement is not met, momentarily depress the HI switch on the YL-1B circuit pack.
6	On the YL-1B circuit pack, momentarily depress LO switch. Requirement: HI lamp extinguishes. Note: If this requirement is not met, replace YL-1B circuit pack and repeat this procedure from Step 5.
7	On the YL-1B circuit pack, depress and hold HI (BOOST on YL-1) switch for approximately 10 seconds or until HI lamp comes on. Requirement: HI lamp lights. Note: If this requirement is not met, replace YL-1B circuit pack and repeat this procedure from Step 5.
8	Using VOM conditioned to read dc volts, insert negative test lead in I CHG 64V jack and positive test lead in I CHG BAT 1 jack on YL-1B circuit pack. Requirement: Meter indicates approximately 0.4 volts dc. Note 1: For fully charged batteries, VOM will read an initial charge and then the voltage will decrease quickly. It may be necessary to depress the LO switch, then the HI switch to verify the initial charge.

CHART 3 (Cont)

STEP

PROCEDURE

Note 2: If this requirement is not met, battery shelf fuse(s) may be blown or missing, YL-1B circuit pack may be defective, cabling between battery shelves and 3A battery charger may be faulty, or 3A battery charger may be defective.

9 Leaving the negative test lead in the I CHG 64V jack, remove the positive test lead from the I CHG BAT 1 jack and insert in the I CHG BAT 2 jack.

10 Repeat Step 8 for I CHG BAT 2 jack.

11 Using VOM on 60 volt dc scale, insert the positive test lead in +48 jack and the negative test lead in -48 jack on the 3A battery charger.

Requirement: Meter indicates between 48 to 50 Vdc.

Note: If this requirement is not met, replace 3A battery charger and repeat this procedure from Step 2.

12 On YL-1B circuit pack, momentarily depress LO switch.

Requirement: HI lamp extinguishes.

Note: MN ALM lamp on YL-1B circuit pack may light if batteries are sufficiently discharged.

13 On one of the battery shelves or on the control box assembly (37A cabinet), remove any BAT (BATT) fuse.

Requirement 1: MN ALM lamp lights on YL1B circuit pack.

Note 1: If this requirement is not met, replace the YL-1B circuit pack and repeat this procedure from Step 5.

Requirement 2: Verify, via the order wire, that a RPFT alarm is indicated at the alarm location.

Note 2: If this requirement is not met, trouble may be in the YL-1B circuit pack, connections between the 3A battery charger and the 6A power panel (P111A & B leads), 6A power panel alarm circuitry, or wiring between the 6A power panel and the alarm lamp location.

14 Reinstall BAT (BATT) fuse.

15 With VOM connected to 3A battery charger 48V test jacks, remove AC PWR fuse.

Requirement 1: Meter indicates greater than 48 volts dc.

Note: If this requirement is not met, replace the 3A battery charger and repeat this procedure from Step 2.

Requirement 2: RPFT alarm is indicated at the alarm location.

CHART 3 (Cont)

STEP	PROCEDURE
	Requirement 3: PWR ALM lamp lights on YL1-B circuit pack.
	Note: If this requirement is not met, replace YL1-B and repeat this procedure from Step 5.
16	Reinstall the AC PWR fuse (HI lamp lights within 30 seconds and the PWR ALM lamp extinguishes).
17	On the battery shelves or control box assembly (37A cabinet), remove both negative (-) BAT (BATT) fuses.
18	On the 3A battery charger, remove the AC PWR fuse and leave out for more than one minute (or until relay click is heard and VOM indicates voltage of less than 10 volts dc).
19	Reinstall the BAT (BATT) fuses.
20	On the 3A battery charger, momentarily depress RESTART switch.
	Requirement: Meter indicates greater than 48 volts dc.
	Note: If this requirement is not met, replace the 3A battery charger and repeat this procedure from Step 2.
21	Reinstall AC PWR fuse (HI lamp lights within 30 seconds).
22	Momentarily depress LO switch (HI lamp extinguishes).
23	Momentarily depress HI switch (HI lamp lights within 10 seconds).
24	Remove VOM connections from the 3A battery charger.
25	On the 6A power panel, verify that 200A gas tube protectors are installed for all the designations on the backside of the protector panel cover (Fig. 1).
26	Get a WN15 LFC plug-in unit and set powering and simplex options (Fig. 8) per SLC-96 facility record for system span being powered.
	Note: Option switches on the LFC plug-in are pulled out to be rotated and pushed back in to select options W, X, Y, and Z. Simplex options are selected by placing the option plugs on the black position adjacent to the appropriate option letters. The remaining option plugs are placed on the white (storage) position adjacent to the unused option letters.
27	On the 6A power panel, locate the appropriate plug-in slot for span being powered (per SLC-96 facility record) and insert the LFC plug-in.
28	Locate the appropriate fuse holder for the LFC plug-in just installed and insert a good 70H (3/4 amp) fuse.

CHART 3 (Cont)

STEP	PROCEDURE
29	Using a VOM conditioned for dc volts (300 volts dc scale), insert the positive test lead in +V jack and the negative test lead in -V jack on the LFC plug-in. Record for future reference the voltage indicated on meter. Note: TST switch on LFC plug-in must be depressed to obtain the voltage reading.
30	Remove VOM test leads from LFC plug-in and set scale selector on 3 volts dc scale.
31	On LFC plug-in, insert the positive test lead in +V jack and the negative test lead in -I jack. Requirement: Meter indicates between 0.5 to 0.7 volts dc. Note: TST switch must be depressed to obtain the voltage reading.
32	Remove both VOM test leads from the LFC plug-in. Insert the positive test lead in +I jack and the negative test lead in -V jack. Requirement: Meter indicates between 0.5 to 0.7 volts dc. Note 1: TST switch must be depressed to obtain voltage reading. Note 2: If either requirement in Steps 31 or 32 fail, remove fuse and replace the LFC plug-in. Then repeat procedure from Step 26 for replacement plug-in.
33	Repeat procedures from Step 26 for each WN15 LFC plug-ins to be installed.
34	After all the required LFC plug-ins are installed and tested, using VOM conditioned for dc volts (60 volt scale), insert the positive test lead in +48V jack and the negative test lead in -48V jack on the 3A battery charger.
35	Remove AC PWR fuse for 10 minutes on 3A battery charger. Requirement: Meter indication does not drop below 47 volts dc or fluctuate. Note: If this requirement is not met, reinstall AC PWR fuse and replace battery packs, one at a time, until bad battery pack is found by repeating Step 35 for each replaced battery pack.
36	After 10 minutes, reinstall AC PWR fuse (HI lamp lights within 30 seconds).
37	Momentarily depress the LO switch on the YL1B circuit pack (HI lamp extinguishes).
38	Momentarily depress HI switch (HI lamp lights within 30 seconds). Note: HI lamp will stay lighted for 24 hours.

CHART 3 (Cont)

STEP	PROCEDURE
39	Push the door alarm plunger to the inner detent (alarm) position and verify, via order wire, that the RPFT alarm is lighted at alarm location.
40	If the RPFT is mounted in a 37A cabinet, pull the door alarm plunger back out to the outer detent (no alarm) position and repeat Step 39 for the second door alarm plunger.
41	Remove all test connections.
42	Firmly secure RPFT doors and let batteries charge for 24 hours.

CHART 4

FINAL TEST

STEP

PROCEDURE

Prerequisite: The procedures of Chart 3 must have been successfully completed. Batteries must have been on charge for at least 24 hours.

- 1 Verify that the HI lamp and the PWR ALM lamp are extinguished on the YL-1B circuit pack.

Note: HI lamp will be lighted if the HI switch has been depressed within the last 24 hours.

- 2 Verify that the MN ALM lamp is extinguished.

- 3 Using a VOM conditioned to read dc volts (60 volt scale), connect test leads as follows:

In the 37A cabinet:

Positive test lead to BATT+ jack (string 1) on the control box assembly.

Negative test lead to BATT- jack (string 1).

In the AT-8908M cabinet or frame-mounted RPFT:

Positive test lead to +BAT jack on lower 128A battery shelf.

Negative test lead to -BAT jack on same shelf.

Requirement: VOM indicates at least 54.5 volts dc.

Note: If this requirement is not met, remove +BAT (BATT+) fuses for this shelf and replace battery packs, one at a time, until defective battery pack is located.

- 4 Repeat Step 3 for second battery string.

- 5 Remove all test equipment and secure cabinet doors (37A or AT-8908M cabinet).

CHART 5

**INSTALLATION OF SUBSEQUENT SLC-96
SYSTEMS WITH AN EXISTING RPFT**

STEP	PROCEDURE
	<p>Note: These procedures assume all initial turnup testing has been completed to verify proper operation of the 3A battery charger, batteries, and alarms.</p>
1	Get a WN15 LFC plug-in for each SLC-96 power span to be powered from this remote powering site.
2	On the LFC plug-in, set powering and simplex options (Fig. 8) per SLC-96 facility record for the system-span being powered.
	<p>Note: Option switches on the LFC plug-in are pulled out, rotated, and pushed back in to select options W, X, Y and Z. Simplex options are selected by placing the option plugs on the black position adjacent to the appropriate option letters. The remaining option plugs are placed on the white (storage) position adjacent to the unused option letters.</p>
3	On the 6A power panel, locate the appropriate plug-in slot for span being powered (per SLC-96 facility record) and insert the LFC plug-in.
4	Locate the appropriate fuse holder for the LFC plug-in just installed and insert a good 70H (3/4 amp) fuse.
5	Using a VOM conditioned for dc volts (300 volt dc scale), insert the positive test lead in +V jack and the negative test lead in -V jack on the LFC plug-in.
	Record for future reference the voltage indicated on the meter.
	<p>Note: TST switch on the LFC plug-in must be depressed to obtain voltage reading.</p>
6	Remove the VOM test leads from the LFC plug-in and set the scale selector on 3 volts dc scale.
7	On the LFC plug-in, insert the positive test lead in +V jack and the negative test lead in -I jack.
	<p>Requirement: Meter indicates between 0.5 to 0.7 volts dc.</p>
	<p>Note: TST switch must be depressed to obtain the voltage reading.</p>

CHART 5 (Cont)

STEP	PROCEDURE
8	Remove both VOM test leads from the LFC plug-in. Insert the positive test lead in +I jack and the negative test lead in -V jack. Requirement: Meter indicates between 0.5 to 0.7 volts dc. Note 1: TST switch must be depressed to obtain the voltage reading. Note 2: If either requirement in Steps 7 or 8 fail, remove fuse and replace the LFC plug-in. Then repeat this procedure from Step 2 for replacement plug-in.
9	Repeat these procedures from Step 2 for each WN15 LFC plug-in to be installed.
10	Remove all test equipment and secure cabinet door(s) (37A or AT-8908M cabinet).

6. MAINTENANCE

6.01 The cause of trouble encountered during turn-up and maintenance of the RPFT will be found in one of the following categories:

- Failure in electronics
- Faulty battery (or batteries)
- Incorrect wiring in the RPFT
- Outside plant problems including cable faults and cross-connect wiring.

6.02 Most troubles in system electronics can be corrected by replacing a defective circuit pack. Appropriate repair procedures should be used to repair the outside plant cable.

6.03 When a RPFT alarm occurs, one of the following problems could initiate the alarm:

- Open cabinet door (37A or AT-8908M cabinet)
- Commercial ac power interruption or blown AC PWR fuse on the 3A battery charger

- Battery string voltage dropping below 54.5 volts dc or blown battery shelf fuse(s)

- Loss of -48 Vdc power from the 3A battery charger or blown FA (alarm) fuse.

6.04 If commercial ac power interruption occurs, the RPFT will be operating on the standby batteries and the PWR ALM lamp on the YL1-B circuit pack will be lighted. If the RPFT is equipped with a YL1 circuit pack, no alarm will be lighted.

6.05 If complete failure of the RPFT is indicated, trouble may be in the power control unit (YL1B circuit pack) or the 3A battery charger. If the battery string becomes sufficiently discharged with an ac failure, complete failure of the RPFT will occur also.

6.06 A partial powering failure of the RPFT could indicate a line feed converter (LFC) plug-in failure. Each LFC plug-in powers one T1 digital line power span. In this case, the fuse for the LFC, or the LFC plug-in itself may be at fault.

6.07 If the LFC plug-in or the digital line is suspected of trouble, the converter output

voltage (+V to -V test jacks on the LFC plug-in) may be measured and compared to the recorded output voltage measured when the plug-in was initially installed.

6.08 If this voltage is significantly different from the previously recorded voltage, the LFC output current should be measured. This is accomplished

by measuring the dc voltage between the +V and -I test jacks and then between the +I and -V test jacks. Both measurements should be between 0.5 to 0.7 volts dc. If this requirement is not met, the LFC plug-in is at fault. If this requirement is met, but the output converter voltage is significantly different (from the previously recorded voltage), then the digital line may be at fault.