

SEE ADDENDUM

CLIMBING PRECAUTIONS

1. GENERAL

1.01 The tests and inspections described in this section should be performed, except as stipulated before climbing a pole or placing a ladder against a pole, against the strand in a pole-to-pole span or a pole-to-building span.

1.02 Further tests required when hanging an aerial platform or riding strand in a cable car are outlined in Sections 620-131-010, 630-132-010, and 627-295-500. If the results of tests indicate poles must be temporarily supported, refer to Section 620-133-010.

1.03 It is unnecessary to make tests or to apply a temporary support before climbing a pole, if *any* of the following conditions will exist throughout the work operations:

- (a) The pole is storm guyed on four sides.
- (b) The pole carries two or more storm side guys and a load as described in 1.04 (b).
- (c) The pole is part of an H fixture which is provided with head and back guys.
- (d) The pole is not in a straight section of a line, but is an adequately guyed corner pole and carries a load as described in 1.04 (b).

1.04 It is also unnecessary to make tests or to apply a temporary support before climbing a pole if *all* of the following conditions exist throughout the work operations and the proposed work operations do not involve placing a heavy unbalanced load (excess of 150 pounds) on the pole:

- (a) The pole is in a straight section of line, but is not a dead-end pole.
- (b) The pole is carrying a 6M or larger suspension strand which is securely clamped to it and

to each adjacent pole and will remain so attached throughout the work operations.

- (c) There is no downward change in grade at the pole.
- (d) Neither adjacent span length is in excess of 165 feet.

1.05 It is also unnecessary to make tests or to provide supplementary supports before climbing a pole if the following conditions exist:

- (a) Instead of carrying a suspension strand, the pole carries ten or more copper, copper-steel, or steel line wires which will remain securely tied at the pole and at each adjacent pole throughout the work operation.
- (b) All the other conditions described in 1.04 (a) (c), and (d) exist

1.06 It is unnecessary to make tests before placing any strand-supported equipment if the following conditions exist:

- (a) The poles supporting the span and the poles at the far end of the adjoining spans form a straight section.
- (b) The suspension strand in the span is 6M or larger and is securely clamped to the two adjacent poles on each side of the span, and will remain attached to these four poles throughout the work operation.
- (c) There is no downward change in grade at the poles at each end of the span.
- (d) The span length and the adjacent span lengths are not in excess of 165 feet each.

2. POLES—PRECAUTIONS AND TESTING

Precautions

2.01 An end pole in a line, even though head guyed, should always be examined and tested before climbing since the guy and the end spans do not contribute any stability to the pole in a direction across the line.

2.02 *No work aloft should be started unless the workman is satisfied that the pole line structure has adequate strength to support the load resulting from working aloft and the load which will result from the proposed work operations. If the strength of the pole line structure is in doubt, temporary or permanent supports must be applied before starting work.*

2.03 The failure of a pole is usually due to one or more of the following causes:

- (a) Decay of the pole at or below groundline.
- (b) Storm damage.
- (c) Mechanical damage, such as might result from a vehicle collision.
- (d) Termite, carpenter ant, or other insect attack.
- (e) Lightning damage or fire damage.
- (f) Woodpecker attack.
- (g) Application of excessive loads or creating unbalanced loads which are excessive under the existing conditions. These excessive loads may result from the use of improper or inadequate construction or maintenance methods.

2.04 Before climbing a pole or testing it for safe climbing conditions, make a visual check for the following conditions:

- (a) Excessive rake or unexplained leaning of a pole. This may be due to failure of the pole at or below groundline.
- (b) Insufficient depth of setting. This may be due to erosion of the earth around the pole as a result of heavy rainfall, flood water, road widening, etc, and would affect the stability of

the pole. The depth of setting can frequently be checked by reference to the brand which is present on most poles at a distance of ten feet (measured to the bottom of the brand) from the butt of the pole. Do not rely upon the brand mark to determine the depth of setting of non-Bell System poles.

- (c) Evidence of collision damage if the pole is at an exposed location along a highway.
- (d) Presence of fungus growth in checks or protruding from the pole surface or on areas near groundline where the wood appears water-soaked in contrast to surrounding wood. These symptoms usually indicate a condition of advanced decay in the interior of the pole.
- (e) Presence of termite or carpenter ant infestation, evidenced by mud channels or debris in the checks, wood dust at the base of the pole, or movement of ants when the pole is stuck with a hammer or other tool.
- (f) Bent, loose, or missing pole steps.
- (g) Wide seasoning checks which could result in loosening of pole steps or a climbing hazard.
- (h) Evidence of compression wood indicated by short horizontal cracks along one side of the surface of the pole, or by curling of short sections out away from the pole surface.
- (i) Presence and distribution of large knots, excessive knot clusters, climber gaff splinters, unauthorized signs, aerials, clotheslines, and nearby interfering tree growth.
- (j) Presence of large stones, ground irregularities, and debris at base of pole.
- (k) Presence of conduits or vertical runs on pole which might interfere with use of pole steps or climbing.
- (l) Broken wires in adjacent span.
- (m) Excessively tight or excessively slack drop or line wires on one side of pole.
- (n) Contact or insufficient separation between telephone and power wires or other plant

on the pole, or in the span or spans adjacent to the pole.

- (o) Woodpecker holes.
- (p) Evidence of lightning or fire damage.
- (q) Presence of markings or pole tags placed by pole inspector to indicate an unsafe pole or pole to be replaced.
- (r) Presence of ice on the pole surface or pole steps which might result in hazardous climbing.
- (s) Shell rot decay on cedar poles.

2.05 Swinging rapidly around a pole imposes an additional load on any pole and should be avoided.

2.06 Where a work operation is planned which is likely to result in a shock load on a pole or on an adjacent pole, a workman should remain off the pole to avoid being shaken off by the shock load. If the shock load would be likely to break the pole, temporary guys should first be placed to take up the shock.

2.07 *Heavy unbalanced loads, such as those caused by placing or removing conductors or strands under tension at unguyed poles or inadequately guyed corners or deadends, may cause even a pole in good condition to fail.* Therefore it is important to plan the work operations so the poles will not be subjected to too heavy an unbalanced load. The use of guys or braces provides a means of preventing excessive unbalanced loads. Typical operations for which temporary or permanent supporting of poles may be required are as follows:

- (a) Removal of guys.
- (b) Untying wires.
- (c) Releasing wires or strand under tension. *Do not cut while under tension.*
- (d) Placing additional wires or strand.
- (e) Tensioning wires or strand.
- (f) Changing locations of wire or strand attachments.

(g) Loosening suspension clamps or guy clamps.

(h) Moving line because of road widening.

Testing

2.08 *In any case where suitable means for determining the condition of a pole and bracing it when necessary are not available and there is any question about the pole being sufficiently strong to permit safe climbing and safe working, do not climb the pole.* Inform your supervisor about the condition and request the necessary assistance to enable the work to be done safely.

2.09 Each of the methods of testing listed below has certain limitations and may not be applicable under the conditions existing at certain locations. It is important, therefore, to make a selection of the tests that are applicable and most suitable under the existing conditions. The tests are as follows:

- (a) Pike Pole Test
- (b) Prod and Sounding Test
- (c) Boring Test
- (d) Hand Line Test

2.10 The pike pole test is applied by making a vigorous effort to rock the pole back and forth in a direction at right angles to that of the line by pushing the pole with a 12-foot or longer pike pole. If practicable, the pike pole should be held at an angle of about 45° with the pole. If the pole cracks or breaks, the test should be discontinued immediately and the pole should be regarded as unsafe for climbing. The pole should not be rocked so hard as to cause the wires to swing together and thus introduce trouble in the circuits.

2.11 If in certain cases (particularly in connection with the longer spans of telephone open wire and power wires) it is found impracticable to rock the pole without causing the wires to swing together, the pole should be given a steady push with the pike pole, applying as heavy a push as possible. If the pole withstands such a push, it should also be subjected to the prod and sounding test before being climbed.

2.12 If a 16-foot pike pole is available, its use is preferred to that of a shorter size, inasmuch as it enables the push to be applied at a higher point on the pole and is therefore more effective. In those cases, however, where a 16-foot pike pole is not available, use may be made of a standard 14-foot or 12-foot pike pole or a standard 1-3/4 inch test-pike, fitted with two extension sections of the large tree pruner handle. As an alternative to the 1-3/4 inch test-pike, a standard 1-1/4 inch test-pike may be used, and it should be fitted with a tapered section and one extension section of a large tree pruner handle.

2.13 The pike pole test cannot effectively be applied to poles that have attachments such as wires, guys, push braces, etc., arranged in such a manner as to take the thrust of the pike, rather than permitting the thrust to be transferred directly to the pole. Some locations at which such conditions are encountered are guyed corner poles, junction poles, side storm guyed poles, etc.

2.14 Many of the small poles in suburban or rural leads, carrying eight wires or less have sufficient strength from a service standpoint, but can be broken by applying the pike pole test too vigorously. In applying the test to such poles, exercise reasonable care to prevent breaking those which are in serviceable condition and can be climbed safely.

2.15 Pavement or frozen ground surrounding poles sometimes tends to hold poles firmly, even though they may be badly deteriorated. Where such conditions exist, it is usually desirable to apply temporary supports to the pole, if there is any question as to the soundness of the pole.

2.16 *The pike pole test should not be applied to poles which, if they were to break off, might cause damage to nearby property or result in contact between telephone plant and electric light or power wires, or introduce some other hazardous situation.*

2.17 The tool used for the prod test is a pole inspector's prod or screwdriver having a 5-inch or longer blade. It is undesirable to use a heavy, pointed tool, such as a digging bar, because of the damage which such a tool can cause to the treated sapwood of a sound pole, thus reducing the effectiveness of the preservative treatment

and exposing the interior of the pole to decay attack.

2.18 Inasmuch as the section of maximum decay is normally encountered between the groundline and a point about 12 inches below the groundline, it is desirable, if conditions permit, to excavate sufficient earth from around the pole to permit a more satisfactory examination of the pole. If, however, the pole is set in pavement, or for other reasons, it is impracticable to remove any earth, the prod should be applied as close to the groundline as practicable at any angle of approximately 45 degrees with the pole and completely around the pole. The presence of general sapwood decay or decay pockets will usually be evident from this test.

2.19 If the prod test indicates the presence of extensive decay, it is desirable to apply temporary supports, regardless of the original circumference of the pole, unless supports are not required (Part 1).

2.20 If there is no indication of decay or other reduction of strength in the prod and sounding tests and the pole has been subjected to a moderate pike pole test where conditions permit its use, **25-foot or shorter poles** in straight sections of rural lines carrying eight or less 104 copper or stronger wires with no downward change in grade, and measuring 13 inches or more in circumference at the groundline, may be climbed without placing temporary supports.

2.21 The prod test is not considered as satisfactory as the pike pole test and it should not be completely depended upon to furnish information as to the soundness of the pole.

2.22 The sounding test consists of applying blows with a hammer, such as a drilling hammer, or the back of a hand axe, to the pole surface completely around the pole from points close to the groundline to as high as can conveniently be reached. The presence of a hollow heart condition or advanced internal decay can usually be recognized by the characteristic hollow or dull sound resulting from the blows on the wood. A pole free from decay usually sounds clear and the hammer usually rebounds noticeably when the pole is struck sharply and squarely. Wet surfaces due to recent rains, wet interior near the groundline due to high soil moisture, wide checks, or shakes in the pole near

the surface may change the sound of a solid pole. Care must be taken not to mistake the altered sound due to these causes for the sound associated with internal decay.

2.23 The boring test consists of boring a hole in the pole at a point where internal decay is suspected by means of a 3/8 inch wood boring bit or by means of an increment borer. The condition of the wood can be determined by an examination of the chips or core brought out by the bit. The presence of a hollow heart condition is, of course, revealed by the bit breaking through the wood.

2.24 If a hole is bored in a pole and it is concluded that the pole is in sound condition and the pole is to be left in plant, the hole should be filled by means of a wooden plug. [Ordering information is as follows: Plug, Wooden (length) inches. Plugs come in 2-, 3-, 4-, or 6-inch lengths. Order the length desired.]

2.25 The hand line method consists of applying a series of pulls to a pole with the object of rocking the pole back and forth. In applying this test, use should be made of a 3/8 inch or larger rope, attached to the pole at such a height that the pull can be applied at right angles to the direction of the line and at an angle of about 45 degrees with the pole. The same use limitations and precautions applying to the pike pole test, apply also to this method of testing. In attaching the rope to the pole, the pole should not be climbed, but the rope should be thrown over a fixed attachment, such as a pole step or a crossarm, or a loop should be made at the base of the pole and moved into position by means of a convenient tool, such as a wire raising tool.

2.26 Poles found by the previously described tests to be unsafe for climbing should be marked immediately with a B or C Pole Tag. (Fig. 1). The unsafe condition should be reported promptly to your supervisor.

2.27 If the pole has been broken, resulting in an unsafe condition and requiring immediate support, temporary supports should, if practicable, be applied immediately to prevent the pole from falling. If suitable bracing means are not available, steps should be taken to warn passers-by or traffic away from the location until a safe condition can be restored and a report of the condition should be made promptly to your supervisor.

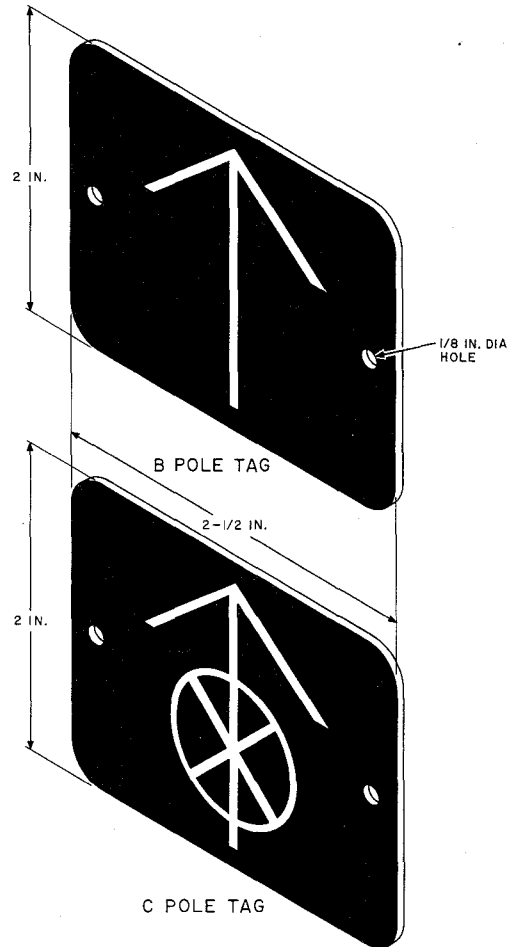

Fig. 1—B and C Pole Tags

2.28 The B Pole Tag has a white arrow on a red background. It is intended for marking defective poles which do not require immediate replacement, that is, defective poles which are not yet considered dangerous.

2.29 The C Pole Tag is similar to the B Pole Tag except that an "X" inscribed in a circle is imposed on the shaft of the arrow. This tag is intended for marking poles which are in a dangerous condition and require immediate replacement.

2.30 Place one tag on the road side of the pole just below the pole number, if the pole is numbered, or at approximately 6 feet above groundline if the pole is not numbered. Place another tag at approximately the same height on the field side of the pole. If the pole is defective in the groundline section, place the tags so that the arrow points downward. If the pole is defective in the upper portion, place the tags so that the arrow points upward. If, however, the pole is defective in both the groundline section and in the upper portion place a double set of tags, one set with the arrow pointing downward and the other set with the arrow pointing upward. Attach the tags with Pole Tag Nails.

3. STRAND-PRECAUTIONS AND TESTING

Precautions

3.01 Vehicles, tools, and equipment that might be damaged as a result of strand breakage should not be located under the strand when it is being tested. Only the individuals involved in making the test should be permitted in the work area.

3.02 On joint use lines or at power crossings, the rope used for testing shall not be thrown over the strand. Pass the rope over the strand with a tree pruner handle or place it over the strand at the pole and move the rope along the strand to the desired location.

3.03 Do not make a mechanical test in spans that cross over electric light, power, fire alarm, or trolley wires. Make a careful visual inspection of the span from the ground. Then, from a working position on the poles, examine the strand adjacent to each of the supporting poles. If any of the following defects are found, the strand must be repaired before performing any work operation that will place an additional load on the strand.

- (a) *Corrosion of the strand* to the extent that no galvanizing remains.
- (b) *Strand wire breaks* in one or more of the strand wires.
- (c) *Excessive strand wear* caused by rings, tree interference, cable guards, etc.

(d) *Any loose attachments* affecting the structure within reach of the workman.

3.04 If any defects are found and work operations must be performed on the cable prior to making repairs on the strand, use a ladder platform or aerial lift truck or place an auxiliary strand to work from.

3.05 Do not make a mechanical test of a span that crosses over a main line railroad track. If the strand has been in place less than one year or if it is known that no coal-burning locomotives have been in use under the strand since it was placed, examine the strand as prescribed in 3.03. *If the strand has been exposed to coal-burning locomotive smoke and is more than one year old, it shall not be ridden.* All work operations shall be performed from a ladder platform or aerial lift truck or from an auxiliary strand. A truck shall not be used within 10 feet of the railroad track.

3.06 Do not make a mechanical test of a span that crosses an electrified railroad. All work operations shall be performed from a ladder platform or aerial lift truck or from an auxiliary strand. A truck shall not be used within 10 feet of the railroad track.

3.07 Do not make a mechanical test of any strand that has been in contact with a power wire. Immediate replacement or repair of the strand is necessary.

3.08 Spans over non-electrified spur railroad tracks may be given a mechanical test provided signalmen are posted along the tracks in both directions and at sufficient distance from the work location to give ample warning of approaching trains.

3.09 Strand crossing streets and highways where no power crossings are involved may be given a mechanical test provided proper warning signs are posted and all traffic is stopped during the test. For those locations where the traffic cannot be stopped, do not make a mechanical test, but follow the procedures in 3.03.

3.10 Before testing suspension strand or the strand of self-supporting cable, examine the span from the ground for:

- (a) The presence of power crossings, power clearances, etc, that may prevent testing the strand.
- (b) Strand abrasion or corrosion, particularly at points of tree interference, strand splices and dead ends, strand attachments, etc, and for any other irregularities of the strand, cable, lashing wire, or rings which may require attention. Observe self-supporting cable spans closely as the covering on this strand may hide possible defects.

3.11 Before placing a ladder against suspension strand or the strand of self-supporting cable, the strength of the strand and its supports should be tested in the following manner:

- (1) Inspect and test the poles at each end of the span (Part 1 and 2).
- (2) Throw or place the handline (3.02) over the strand at the point where the ladder is to be placed.
- (3) The workman who will work from the ladder should grasp the two ends of the handline and gradually apply his full weight to the strand by lifting himself slowly off the ground (Fig. 2).

3.12 Be alert for visual or audible signs of weakness. A strand and its supports which will support the workman without showing any signs of failure or slippage have ample strength to support the ladder and the workman.

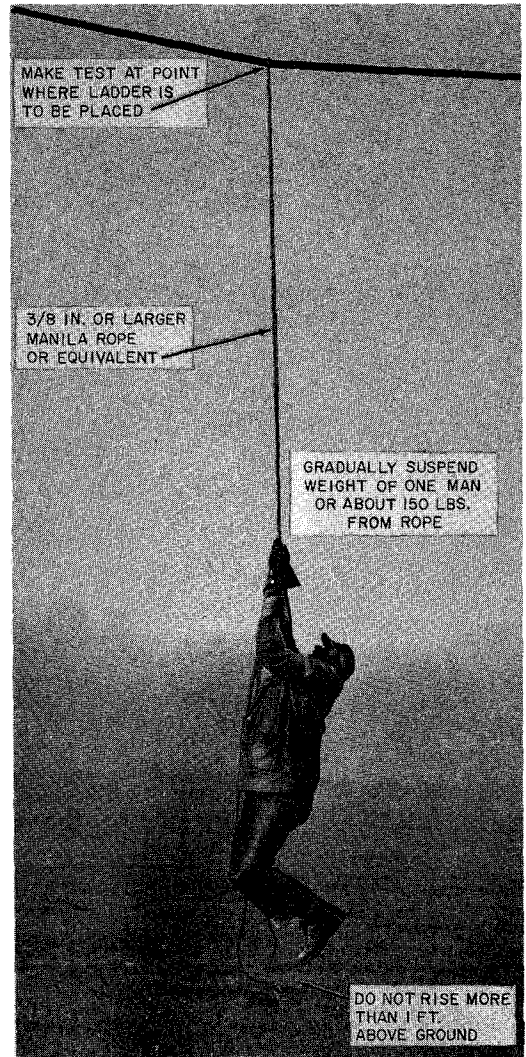

Fig. 2—Testing Strand Prior to Placing Ladder

CLIMBING PRECAUTIONS

1. GENERAL

1.001 This addendum supplements Section 460-300-110, Issue 1. Place this pink sheet ahead of Page 1 of the section.

1.002 This addendum is reissued to change the section numbers in Division 620 referred to in the section and in Issue 1 of this addendum.

1.003 Issue 1 of this addendum was issued to clarify whether or when a pole can be climbed if a B or C pole tag has been affixed to a pole.

2. CHANGES TO SECTION

ISSUE 1 CHANGES

2.001 On Page 1, revise paragraph 1.02 as follows:

1.02 Further tests required when hanging an aerial platform or riding strand in a cable

car are outlined in Sections 620-131-010 and 627-295-500. If the results of tests indicate poles must be temporarily supported, refer to Section 620-131-010.

ISSUE 2 CHANGES

2.002 On Page 5 add the following to paragraph 2.28:
It serves as a warning to craftspeople that the pole is defective and should *not* be climbed or worked on without following the recommendations of Section 620-131-010.

2.003 On Page 5 add the following to paragraph 2.29:
It serves as a warning to craftspeople that the pole is in a dangerous condition and should not be climbed or worked on before being temporarily supported as described in Section 620-131-010.

NOTICE

Not for use or disclosure outside the
Bell System except under written agreement