

STATION WIRE AND CABLE ATTACHING AND FASTENING

	CONTENTS	PAGE
1.	GENERAL	1
2.	SURFACES ENCOUNTERED	1
3.	ATTACHING AND FASTENING GROUND WIRE	5
4.	ATTACHMENTS USED IN FINISHED ROOMS AND OFFICES	6
5.	CELLARS, FACTORIES, OR WHERE APPEARANCE IS UNIMPORTANT	6
6.	ATTACHING TO STEEL STRUCTURES	7
7.	CABLE TIES	7
8.	B CORD CLIP	10

1. GENERAL

1.01 Select proper type and size attachments and fasteners for surfaces encountered. Use galvanized fasteners outdoors and enameled or nongalvanized fasteners indoors.

1.02 This section is reissued to:

- Add Table of Contents
- Provide information on the KS-20986, List 8 cable tie
- Remove information on the B beam clip and B hanger clip which are rated Manufacture Discontinued (MD).

1.03 Table A lists spacing of attachments and Table B clearance and lead holes for fasteners. It is important to use correct size clearance and lead holes for wall fasteners to prevent wall damage. To obtain secure attachments and to avoid damage

to building surfaces, follow the instructions in this section for each type of surface.

1.04 The C wire loop replaces the B (MD) wire loop and will accommodate the same number of wires or cables.

1.05 The B adhesive clip is rated MD. Any existing stock is outdated and should be disposed of according to local regulations.

2. SURFACES ENCOUNTERED

Cement or Cinder Block

2.01 Recommended fasteners are:

- B or C masonry fasteners
- B or C plastic anchors
- B, C, or D drive anchors
- D plastic anchors (used with galvanized wood screws).

If the wall is old and the fastener is not secure, use:

- Toggle bolts
- B wall screw anchors.

If these attachments pull out, install a carriage bolt. Equip bolt with two washers or boards—one under nut and other under head of bolt.

Masonry or Substantial Brick Veneer

2.02 In general, the same fasteners apply in making attachments to masonry and substantial brick veneer. Veneering is considered substantial when:

- (a) The veneer thickness is 3-3/4 inches (as observed at an outside corner).

NOTICE

Not for use or disclosure outside the
Bell System except under written agreement

♦TABLE A♦

SPACING REQUIREMENTS OF ATTACHMENTS

FASTENERS		SPACING				
		HORIZONTAL		VERTICAL RUN		FROM CORNER
		FEET	INCHES	FEET	INCHES	INCHES
Cable Clamps	more than 12-pair cable		16	4		2
	less than 12-pair cable		16		16	2
Cable Clasps	more than 12-pair cable		14	3		2
	less than 12-pair cable		14		14	2
B Station Wire Clamps			16		16	2
B Station Wire Nail			16		16	2
Staples	Station Wire		7-1/2		7-1/2	1
	25-pair D inside wiring cable		12		12	2
Bridle Rings		4				2 thru 8-1/2*
Drive Rings		4		8		2 thru 8-1/2*
Wire Loops		4		8		2 thru 8-1/2*
Toggle Bridle Rings		4		8		2 thru 8-1/2*
Insulator Supports		4		8		2 thru 8-1/2*
B Support Clip	Used on Beams	4		8		2 thru 8-1/2*
	Used on Hanger Wires	As Required				
E Adhesive Cable Tie						

*When changing direction of wire or cable runs where wire loops, bridle rings, drive rings, toggle bridle rings, insulator supports, and B beam clips are used, the fasteners should be spaced to hold the wire or cable at approximately a 45-degree angle.

(b) The bricks are joined firmly with mortar.

On masonry and substantial brick veneer, drill holes for all attachments as close to the center of bricks as practicable and exercise care to avoid damaging and loosening the bricks. In the case of face brick or ornamental types of brick, holes for intermediate and last attachments may be drilled in the seam

to avoid breakage. Wear safety glasses when drilling or hammering.

Thin Wall Brick Veneer

2.03 Thin wall brick veneer is considered as veneering having a thickness of less than 3-3/4 inches (as observed at an outside corner, some

TABLE B
CLEARANCE AND LEAD HOLES FOR FASTENERS AND SCREW-TYPE FIXTURES

FASTENER OR FIXTURE	CLEARANCE HOLE			LEAD HOLE		
	SIZE AND TYPE OF DRILL					
	INSTALLER	POINT	CARBON STEEL TWIST	INSTALLER	POINT	CARBON STEEL TWIST
	IN.					
Toggle Bolt 3/16	Clearance Hole 1/2 or 5/8					
1/4	5/8 or 3/4					
5/16	5/8 or 7/8					
Toggle Bolt Ring 5/8 and 1-1/4	3/4					
S and L Insulated Screw Eyes	3/16 by 5-1/2		No. 12 or 3/16		3/32	No. 42 or 3/32
C Bridle Rings 1-1/4-1-5/8-3					1/8	No. 30 or 1/8
7/8					3/32	No. 42 or 3/32
Drive Rings 5/8 and 7/8					3/32	No. 42 or 3/32*
1-1/4					11/64	
Angle Screw 5/16	5/16 by 7-1/2		5/16		11/64	No. 18 or 11/64
3/8	3/8 by 8		3/8	1/4 by 6-1/2		1/4
Tapping Screw † No. 7		11/64	No. 20		5/64	
No. 8		No. 13	11/64		3/32 or No. 33	
No. 10	3/16 by 5-1/2		No. 12 or 3/16		3/32	No. 42 or 3/32
No. 14	1/4 by 6-1/2		1/4		1/8	No. 30 or 1/8
B and C Masonry Fasteners B, C, and D Drive Anchors B and C Plastic Anchors D Plastic Anchor B Wall Screw Anchor	The maximum holding power of these anchoring devices in any given quality of masonry depends upon obtaining a drilled hole corresponding to the outside diameter of the unexpanded anchor and of sufficient depth to allow the nail to be driven its full length. The diameter and length are generally indicated on the anchor. The depth of hole required varies with the thickness of the fixture to be installed at the point of support. In all installations the minimum depth of hole required is equivalent to the length of the anchor plus the distance the nail or screw will extend beyond the anchor (approximately 3/16 inch).					

Notes:

1. Installer drills are bit stock twist drills and are used in the ratchet brace.
2. Carbon steel twist drills are straight shank drills and are used in the hand drill.
3. Drill points are used in the automatic drill and will drill lead holes approximately 1-1/2 inches deep. Where deeper holes are required, use twist drills in the hand drill.
4. Use L masonry drills for drilling the seam between bricks.
5. Use L masonry drills or star-faced stone drills in drilling holes for toggle bolts. Two sizes of holes are listed to cover the different types of approved toggle bolts. Drill the smaller hole if it will accommodate the toggle bolt.
6. Apply paraffin wax or soap to the threads of wood screws or screw-type fixtures to facilitate turning them into wood.

* Do not drill lead hole in poles.

† Tapping screws have an AB thread suitable for sheet metal or wood and are available with flat or pan head.

corners are mitered) or having bricks that loosen or crack easily when drilled. Make attachments to thin wall veneering as follows:

- (a) **First Attachment:** Attach to suitable woodwork with galvanized wood screws. When suitable woodwork is not available, attach to the brick veneer surface by drilling a clearance hole in the seam to permit a galvanized wood screw to be passed through the brick portion of the wall and screwed into the wood backing or studding. The screw should penetrate at least 1 inch into the wood backing or studding.
- (b) **Intermediate and Last Attachments:** Attach to brick veneer with suitable anchoring device. Drill holes in center of bricks; if bricks begin to crack or loosen, make the attachments in seams or to wood trim. On slab-type veneering (approximately 1 inch thick), secure intermediate and last attachments to the wood backing in the manner specified for first attachments.

Wood

2.04 Staples, galvanized wood screws, tapping screws, or nails are generally the standard fasteners on wood; however, B wall screw anchors, B and C plastic anchors, or toggle bolts are recommended as fasteners on plywood and masonite when a more substantial fastener is needed for heavier apparatus.

2.05 On woodwork, drill lead holes for fasteners and screw-type fixtures to avoid splitting the wood and to obtain maximum holding power. Locate fasteners in studding where practicable.

2.06 Studs in buildings of wood frame construction may usually be located by one of the following methods:

- (a) Buildings finished with clapboards:
 - By location of heads of nails used in fastening clapboards to studding, or where clapboards join.
- (b) Buildings finished with shingles or stucco:
 - By sounding
 - By locating studs in cellar or attic

- By location of heads of nails used in fastening trim to studding.

Stucco on Wood

2.07 On stucco on wood building, attach to substantial wood trim with galvanized wood screws. Where required to install fixtures on stucco finished walls, drill a clearance hole for tapping screw or screw-type fixture, preferably by means of an installer drill in a ratchet brace. If there is a wood backing, the spring of a hammered drill will knock the stucco loose. Use care to avoid cracking the stucco. Locate screws in studding where practicable.

Plaster on Lath, Rock Lath, Plaster Board

2.08 Plastic anchors, B wall screw anchors, or toggle bolts are used to make attachments. However, when a substantial fastener is required for heavier apparatus, it will be necessary to locate the studding as in 2.06 and use tapping screws. The holding power of hollow wall fasteners is such that any movement or shifting of weight tends to loosen them. This must be considered at all times so that costly maintenance and hazards are not built into plant. If wood lath is used under plaster and can be entered by a slanting lead hole, a secure attachment can usually be made. Locate the lath before drilling the attachment hole.

Rigid Composition Shingles

2.09 In general, galvanized wood screws are required in making attachments through composition shingles.

2.10 On buildings finished with rigid composition shingles, make attachments to substantial wood trim where practicable. If suitable wood trim is not available, locate the clearance holes for fasteners on the shingles as outlined in the following:

- (a) Rectangular shaped shingles installed with the long dimension horizontal: Locate the hole midway between the vertical edges of the shingle and approximately 3/4 inch above the bottom edge.
- (b) Rectangular shaped shingles installed with the long dimension vertical: Locate the hole at the midpoint of the visible shingle height

and approximately 3/4 inch from either vertical edge.

(c) Shingles installed in diamond formation: Locate the hole near a nail hole and approximately 3/4 inch from either exposed edge of the shingle.

2.11 When more than one screw is required to attach a drop wire fixture, observe the following in locating the clearance hole for the screw:

(a) House bracket: The distance between the edge of the shingle and the nearest hole should be approximately 3/4 inch.

(b) S or L corner bracket: The bracket should be located so as to bear evenly on the shingles with the hole nearer the porcelain knob located approximately 3/4 inch from the edge of the shingle.

(c) W leader bracket: The bracket should be located so as to bear evenly on the shingles with at least one of the holes located approximately 3/4 inch from the edge of the shingle.

2.12 *Precaution:* Because of the brittleness of rigid composition shingles, and where mounting of attachments cannot be avoided, the following precautions shall be observed:

- (a) Place ladder carefully against the shingles.
- (b) Use only well sharpened drills.
- (c) Never employ drills which require the use of a hammer on composition shingles.
- (d) Do not apply excessive pressure to the brace when drilling clearance holes through the shingles.
- (e) Wood screws should not be tightened excessively as the pressure on the shingle might cause it to break.

Metal (Siding, Paneling, or Desks)

2.13 Be sure protrusion of fasteners will not cause damage or injury. Fasteners for siding,

paneling, or desks can be of the following variety: tapping screw, B or C plastic anchor, toggle bolts, or B wall screw anchors.

2.14 Aluminum siding presents other problems.

The customer should be contacted to determine the type of siding and method used to install it. This will determine type of fastener or attachment to be used. Permission should be obtained at this time for proposed wire runs, etc.

2.15 When using an extension ladder against metal, vinyl, or aluminum siding, use precaution to prevent damage.

Danger: It is possible for foreign voltage to be present on buildings covered with metal siding. Test siding with B voltage tester before starting any work. Refer to Section 460-300-109 for use of a B voltage tester.

3. ATTACHING AND FASTENING GROUND WIRE

Fasteners (Fig. 1)

Note: When nails or tapping screws are used for fasteners, locate so they will enter studding if possible.

3.01 Space ground wire fasteners as follows:

- Space 24 inches apart on ordinary ground wire runs.
- Space 16 inches apart when wire is subject to displacement.
- Place on every beam when spanning beams.
- Place within 3 inches of wall when run parallel to wall on beams (to discourage articles being hung on wire).

Note: Staples are not recommended for use in plaster. The H and J staples replace the E- and F-type staples; the G staple replaces the T-75 staple.

4. ATTACHMENTS USED IN FINISHED ROOMS AND OFFICES



Choose color of attachment to match wire or cable; refer to Table A for spacing requirements.

Staples

4.01 Table C shows the staples recommended for wood surfaces with finishes available and stapler machine used. Staples, H (zinc or ivory), J or G are available.

B Station Wire Nail

4.02 This nail is used to fasten station wire to plaster or wood surfaces. It can be used with D station wire if care is taken to ensure that the smaller diameter wire is sufficiently secure by the arm of the nail.

B Station Wire Clamp

4.03 This clamp is used to support station wire. Table D lists fasteners to be used with clamps.

Cable Clamps and Cable Clasps

4.04 These attachments are used to support inside wiring cable or more than one station wire. Table E lists fasteners to be used with clamps and clasps.

5. CELLARS, FACTORIES, OR WHERE APPEARANCE IS UNIMPORTANT



In general, the same types of attachments used in finished rooms apply for cellars, factories, or where appearance is unimportant. However, they should be of an appropriate finish. In addition to these attachments, drive rings, C wire loops, and toggle bridle rings are also available for use at these locations.

Drive Rings (Fig. 1)

5.01 Drive rings are formed steel loops having a pointed shaft suitable for hammer-driven attachment to wood or masonry surfaces. On wood surfaces, attach drive rings to beams or studding (to avoid injury below the 6-foot level, use bridle rings). On masonry surfaces, use with D drive anchors. Table F shows sizes of rings and anchors.

Note: For masonry surfaces, C wire loops with B masonry fasteners are preferred.

TABLE C
SELECTION OF STAPLES

STAPLES						STAPLER
TYPE	FINISH	SIZE (INCHES)		SHAPE OF CROWN	USE	
		LENGTH	WIDTH			
H*	Zinc or Ivory	3/8	5/32	Rounded	With D station wire and small gauge ground wire in all type wood	E or Heller TMN conversion
J†	Copper Coated					
G*	Zinc Coated	5/8	1/2	Flat	Inside wire cables up to 1/2-inch in diameter	D or T-75

Note: Staples are not recommended for use in plaster.

* For indoor use.

† For outdoor use or where appearance is unimportant.

TABLE D
FASTENERS FOR B STATION WIRE CLAMP

SURFACE	FASTENER
Metal or Asbestos Siding	No. 7 x 1/2-in. PH tapping screw
	No. 6 x 5/8-in. galvanized wood screw. C Plastic Anchor, 3/16 x 1 in.
Wood, Indoors	No. 7 x 1/2-in. PH tapping screw
Wood, Outdoors	No. 6 x 5/8-in. RH galvanized wood screw
Stucco (Wire and Paper Backing)	No. 8 x 1-in. PH tapping screw or wall screw anchor (correct size)
Masonry	No. 2 B Masonry Fastener

C Wire Loop (Fig. 1)

5.02 C wire loops are formed sections of wire used with B masonry fasteners as an intermediate support for station wires and inside wiring cables attached to masonry surfaces. Table G shows sizes of C wire loops.



Wire loops with B masonry fastener are preferred over drive rings in masonry surfaces because the fasteners are driven directly into the masonry surface without a predrilled hole.

Toggle Bridle Ring (Fig. 2)

5.03 This attachment, available in two sizes, 5/8-inch and 1-1/4 inch, is used to attach station wire and cable to hollow surfaces. A predrilled 3/4-inch clearance hole is required.

Note: For best results and a secure installation, clearance holes should be restricted to 3/4-inch diameter.

6. ATTACHING TO STEEL STRUCTURES

B Insulator Support (Fig. 3)

6.01 The B insulator support, equipped with a B, K, or M bridle ring, is used to support wire runs on I beams, angle irons, etc, on beam thickness up to 3/4 inch.

B Support Clip (Fig. 4)

6.02 The B support clip provides a means of attaching drive rings or bridle rings to hanger wires and rods used in false ceiling construction. It can also be used to grip the flanges of structural steel framework. It replaces the B beam clip and B hanger clip.

6.03 This notched spring steel clip has two loops, each providing a fit for the drive rings. In addition, two holes are provided in the face of the clip which will accommodate either a No. 10-24 threaded bridle ring, machine screw, or bolt or a 1/4-20 threaded machine screw or bolt. The clip is intended for inside use only.

6.04 This clip can be used on wire and rod from No. 12 through 3/8-inch diameter and on flanges from 1/8 inch thick to 3/8 inch thick.

6.05 Early B support clips had only one hole in the face for a No. 8 tapping screw.

7. CABLE TIES

7.01 Cable ties are plastic or nylon straps or mounting devices designed for use in customer telephone and switchboard installations to group wires, cords, and inside wiring cables into orderly harnesses.

7.02 **Adhesive cable ties** are intended for use where mounting by adhesion may be desirable or the only acceptable means. The E adhesive cable tie (Fig. 5) replaces both the B adhesive cable tie (Fig. 6) and the C adhesive cable tie.

7.03 The E adhesive cable tie consists of a molded plastic, self-locking, nonreleasing strap slipped through a fitment on a molded plastic, 1-inch square base. The base has a foam adhesive backing on the mounting surface. Screw holes are provided in the base where additional attaching strength is required. The tie is shipped with KS-20986, List 4

TABLE E

FASTENERS FOR CABLE CLAMPS AND CABLE CLASPS

SURFACE	CLAMP NO.	CLASP NO.	FASTENER	REMARKS
	COLOR			
	LIGHT OLIVE GRAY, IVORY, GALVANIZED	LIGHT OLIVE GRAY, IVORY		
Woodwork	No. 3 and 5*	No. 7	No. 7 x 1/2-in. PH tapping screw	
	No. 6, 8, 10, and 12*	No. 9 and 14	No. 7 x 1/2-in. PH tapping screw	
	No. 13 and 17		No. 10 x 1-in. galvanized wood screw	
Plywood, Masonite	No. 3 and 5*	No. 7	No. 7 x 1/2-in. PH tapping screw B Wall Screw Anchor 1/8 in. x 3 in. toggle bolt	Make tapping screw attachments at stud locations. Use No. 1 B Wall Screw Anchor on wall thickness 1/16 in. to 1/4 in. Use No. 2 B Wall Screw Anchor on wall thickness 1/4 in. to 3/8 in. Use No. 3 B Wall Screw Anchor on wall thickness 3/8 in. to 3/4 in.
	No. 6, 8, 10, and 12*	No. 9 and 14	No. 7 x 1/2-in. PH tapping screw 3/16 in. x 1 in. C Plastic Anchor B Wall Screw Anchor 1/8 in. x 3 in. toggle bolt	
	No. 13 and 17		No. 10 x 1-in. galvanized wood screw 1/4 in. x 1 in. C Plastic Anchor B Wall Screw Anchor 3/16 in. x 3 in. toggle bolt	

straps which will accommodate bundles up to 5/8 inch in diameter. Where larger bundles are encountered, a KS-20986 strap of the proper length may be substituted. The E adhesive cable tie is available in ivory and light olive gray colors.

7.04 Observe the following precautions in mounting adhesive cable ties:

- The temperature of the plate and mounting surface should be above 45 degrees fahrenheit.

TABLE E (Cont)

FASTENERS FOR CABLE CLAMPS AND CABLE CLASPS

SURFACE	CLAMP NO.	CLASP NO.	FASTENER	REMARKS
	COLOR			
	LIGHT OLIVE GRAY, IVORY, GALVANIZED	LIGHT OLIVE GRAY, IVORY		
Plaster-board, Plaster on Wood Lath, and Plaster on Metal Lath	No. 3 and 5*	No. 7	No. 7 x 1/2-in. PH tapping screw B Wall Screw Anchor	Make tapping screw attachment at stud locations. Use No. 1 B Wall Screw Anchor on wall thickness 1/16 in. to 1/4 in. Use No. 2 B Wall Screw Anchor on wall thickness 1/16 in. to 3/8 in. Use No. 3 B Wall Screw Anchor on wall thickness 3/8 in. to 3/4 in.
	No. 6, 8, 10, and 12*	No. 9 and 14	No. 8 x 1-in. PH tapping screw 3/16 x 1 in. C Plastic Anchor B Wall Screw Anchor	
	No. 13 and 17		No. 10 x 1-in. RH galvanized wood screw 1/4 in. x 1 in. C Plastic Anchor B Wall Screw Anchor No. 10 x 1-in. PH tapping screw	

*Inside wiring clamp only.

- Initially, the plate must be located accurately as the adhesive backing may damage the mounting surface if removed.
- Mount only on clean, dry surfaces (remove wax or grease).
- Avoid touching foreign objects with adhesive side of plate to prevent picking up dust and lint; do not touch adhesive with hands.
- Apply plate to mounting surface and press firmly.

7.05 C (MD) cable ties and D (MD) cable ties are plastic straps having ratchet buckle and tapered point ends. Detents allow a range of adjustments and permit easy release and reuse. C

cable ties are used as straps for the B adhesive cable tie. The C and D cable ties have been replaced by the KS-20986, List 4 cable ties (Fig. 7). The KS-20986, List 4 cable ties are used as straps for the E adhesive cable ties.

7.06 KS-20986, List 1 through 8 cable ties are nylon self-locking straps which may be tightened over variable sizes of cable groups. They are available in eleven colors with natural and light olive gray (not requiring an ordering code suffix) as basic. Consult Table H for size, color availability, and ordering code suffix information. Their intended use is as follows:

- Lists 1, 2, and 3—Banding and securing switchboard cables and vertical and horizontal cables on distributing frames.

**TABLE F
DRIVE RINGS**

DIMENSIONS IN INCHES				ANCHOR SIZE (IN.)	
SIZE	D	W	L	DIA.	L
1/2	1/2	1/2	2-1/16	3/16	7/8
5/8	5/8	3/4	2-1/4	1/4	1
5/8L	5/8	3/4	2-3/4		
7/8	7/8	1-1/2	2-9/16	1/4	1
7/8L	7/8	1-1/2	3-1/16		
1-1/4	1-1/4	2-3/8	2-15/16	5/16	1-1/4
1-1/4L	1-1/4	2-3/8	3-7/16		

L sizes have extra long shafts and cannot be used with B Drive Anchors.

- Lists 4 and 5—Banding cables on power equipment. ♦Fastening cover on B, C, or D customer service closures.♦
- List 6—Reusable ties for securing switchboard cables on duct-type frames.
- List 7—Securing keyshelf cable(s) in switchboards.
- ♦List 8—Binding and securing cables in switchboards, equipment cabinets, and central offices. Equipped with a tab on the buckle end having a No. 10 screw hole for securing the tie to woodwork, backboards, etc.♦

**TABLE G
C WIRE LOOP**

C WIRE LOOP SIZE NO.	INSIDE DIAMETER	LENGTH OF LOOP (OUTSIDE)	B MASONRY FASTENER FOR		
			CONCRETE	MORTAR	BLOCK*
1/2	1/2 in.	15/16 in.	3	4	5
5/8	5/8 in.	1-1/4 in.			
7/8	7/8 in.	2-1/4 in.			
1-1/4	1-1/4 in.	2-7/8 in.			

*Cement or cinder blocks.

8. ♦B CORD CLIP

8.01 The B cord clip (size 1) provides a means of attaching D station wire to 2012-type transformers to prevent accidentally pulling the wire from the transformer screw terminals.

8.02 The B cord clips come 10 to a package and should be ordered as follows:

1 pkg. (10 clips per pkg.)—Clip, Cord, B1-61

8.03 Remove protective paper from adhesive of B cord clip and stick clip to bottom of 2012-type transformers as shown in Fig. 8. Terminate D station wire on screw terminals of 2012-type transformer and hook station wire through B cord clip as shown in Fig. 8.♦

TABLE H

KS-20986 CABLE TIES – COLOR AVAILABILITY

LIST NUMBER	MAXIMUM BUNDLE DIAMETER (IN INCHES)	BASIC COLOR†		OPTIONAL COLORS (NOTE)									
				BLACK -0	BROWN -1	RED -2	ORANGE -3	YELLOW -4	GREEN -5	BLUE -6	PURPLE -7	CARBON BLACK -X	
		NATURAL	LT. GRAY										
1	2		•	•	•	•	•	•	•	•	•	•	*
2	3		•	•	•	•	•	•	•	•	•	•	
3	4		•	•	•	•	•	•	•	•	•	•	
4	5/8		•	•	•	•	•	•	•	•	•	•	*
5	1-1/4		•	•	•	•	•	•	•	•	•	•	
6	1-3/4		•	•	•	•	•	•	•	•	•	•	
7	4	•		•	•	•	•	•	•	•	•	•	*
8	1-3/4		•	•	•	•	•	•	•	•	•	•	

Note: Add color suffix if other than basic is required, ie, if List 2 in red is wanted, order as KS-20986,L2-2.

* Weathering type (sun resistant).

† No suffix required.

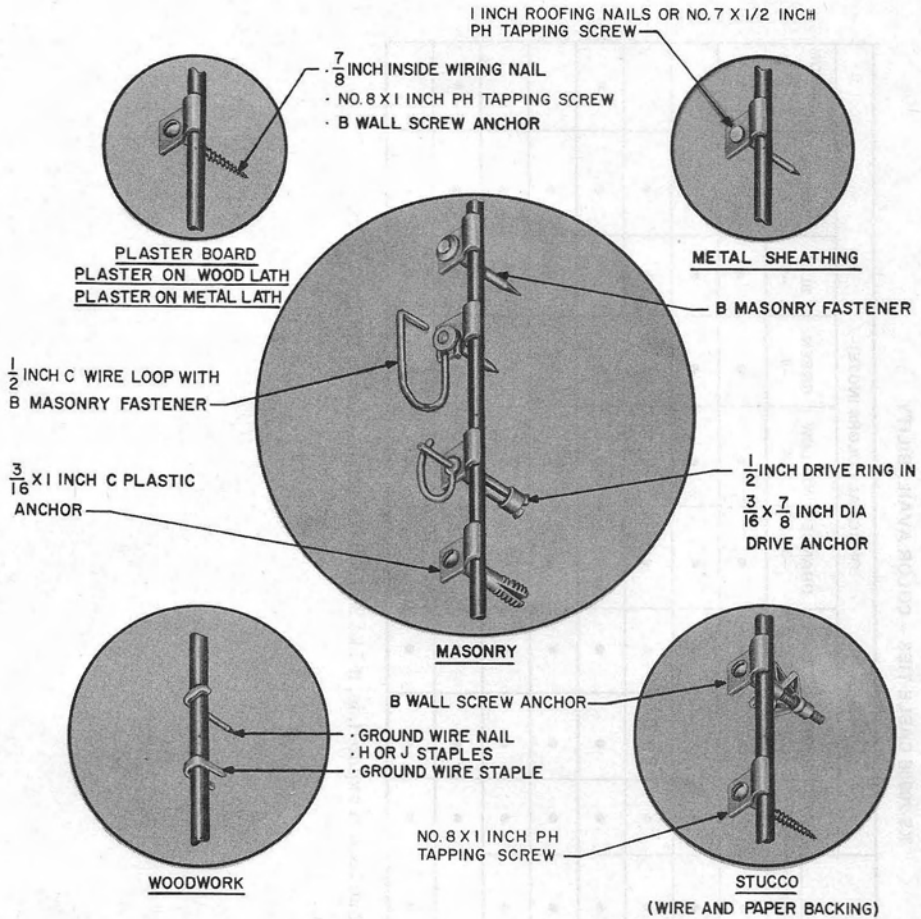

Fig. 1—Fasteners for Ground Wire

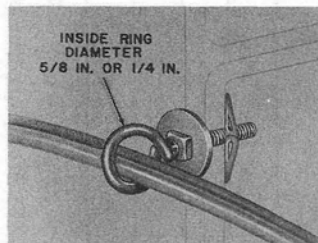

Fig. 2—Toggle Bridle Ring

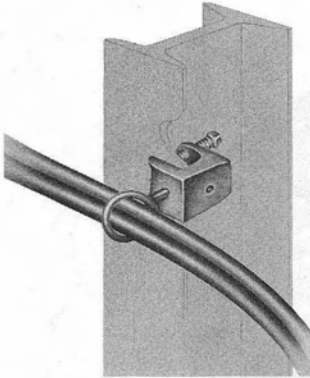

Fig. 3—B Insulator Support

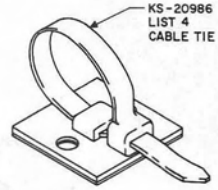

Fig. 5—E Adhesive Cable Tie

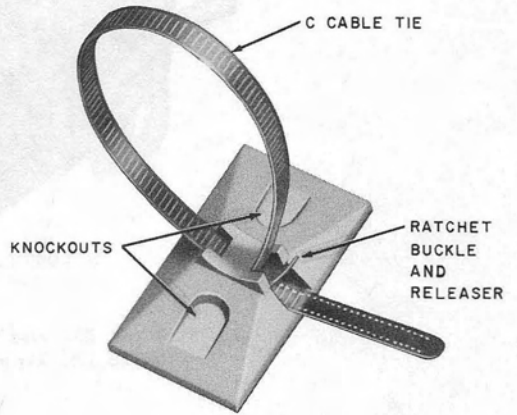

Fig. 6—B (MD) Adhesive Cable Tie

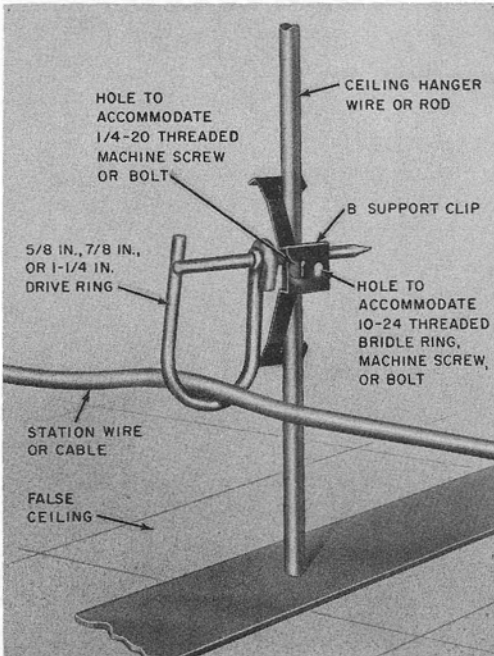

Fig. 4—B Support Clip, Installed

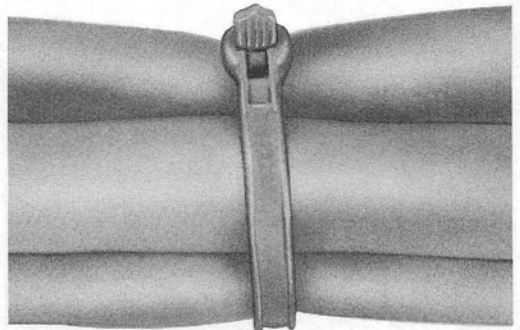

Fig. 7—KS-20986 Cable Tie

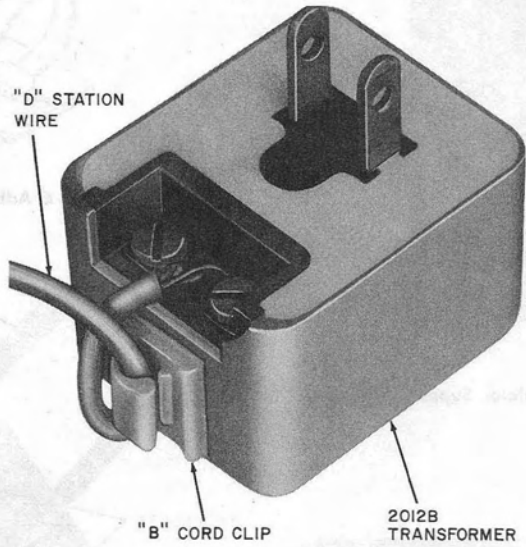

Fig. 8—Cord Clip Used to Secure Station Wire to 2012B Transformer