

SERVICE

COIN COLLECTORS

235- AND 1235-TYPE

1. GENERAL

1.01 This section provides maintenance and connection information for the 235G and 1235G coin collectors. (Fig. 1 and 2).

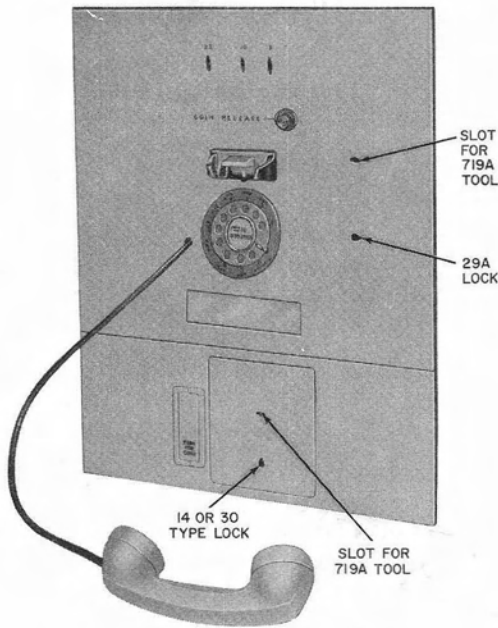

Fig. 1—235G Coin Collector

1.02 Information in this section was formerly contained in Sections 506-321-100, 506-321-400 and 506-321-420 which are hereby canceled.

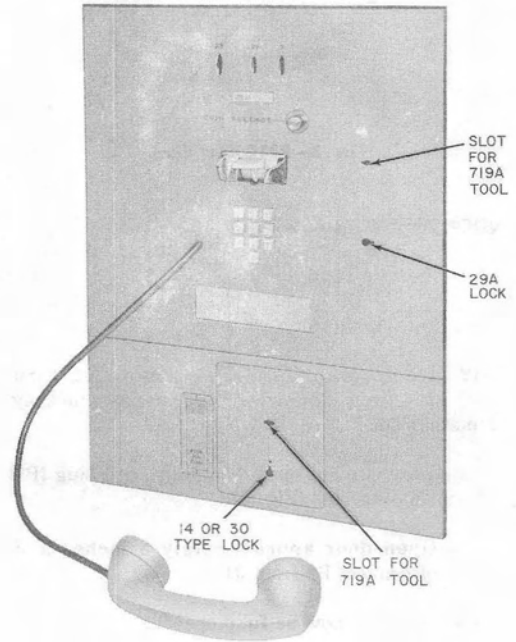

Fig. 2—1235G Coin Collector

1.03 For additional information refer to Division 506, section entitled: Reference Coin Collectors, 235-, 236-, and 1235-Type.

2. MAINTENANCE

2.01 A P11C test cord (Fig. 3) is used to connect plug (P1) to jack (J1) which allows the set to be operative while door and liner assembly is opened.

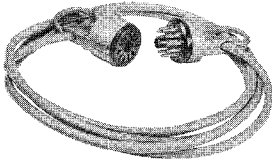

Fig. 3—P11C Test Cord

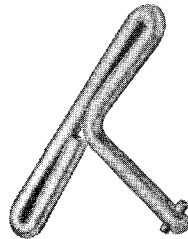

Fig. 4—719A Tool

DOOR AND LINER ASSEMBLY

2.02 To open door:

- (1) Unlock 29A lock.
- (2) Insert 719A tool (Fig. 4) into slot, turn 1/4-turn clockwise, and release locking mechanism.

Note: Do not open door fully until plug (P1) is disconnected (Fig. 5).

- (3) Open door approximately 3 inches and disconnect P1 from J1.
- (4) Door can now be fully opened.

Coin Twister Assembly

2.03 To remove coin twister assembly:

- (1) Loosen screws in middle of twister assembly (Fig. 5).
- (2) Lift P-27E847 coin twister (top section) up and out.
- (3) Remove screws and nuts holding P-44E390 coin twister frame assembly (Fig. 5).
- (4) Lift frame assembly up and off.
- (5) Install, using reverse procedure.

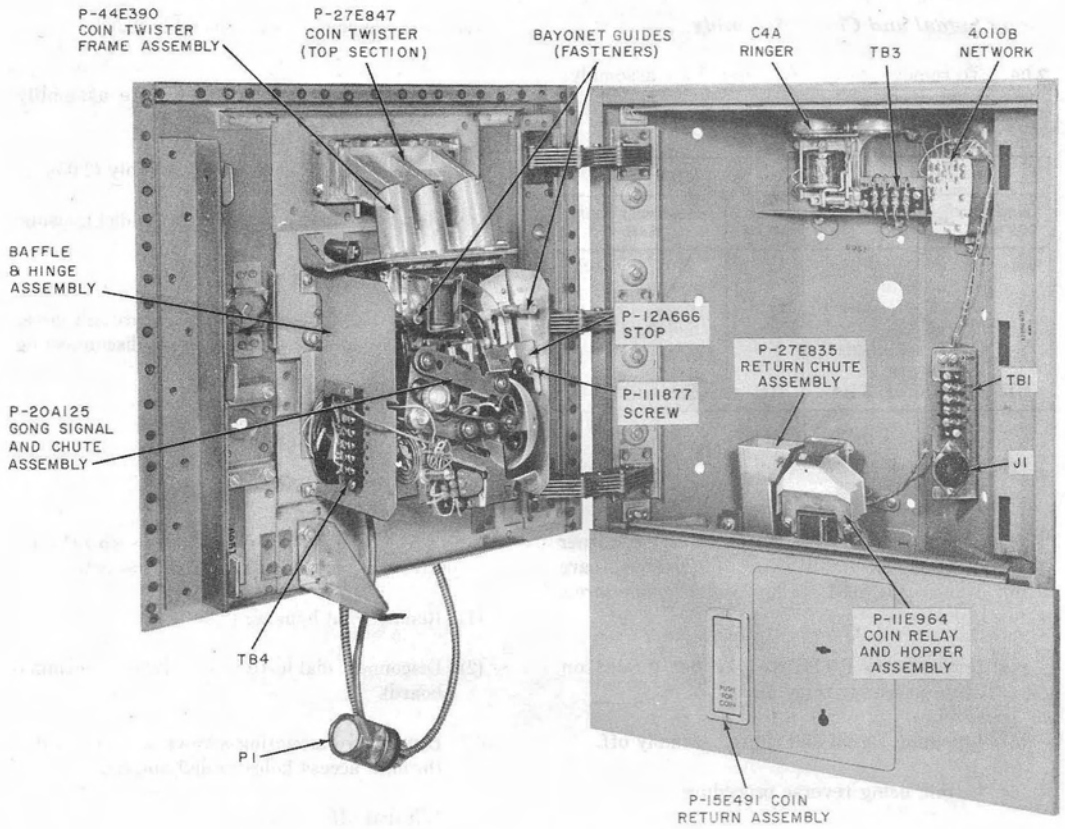

Fig. 5—235G or 1235G Coin Collector—Interior

Gong Signal and Chute Assembly

2.04 To remove gong signal and chute assembly:

(1) Disconnect wires as follows:

235G		1235G	
WIRE COLOR	DISCONNECT FROM TERM.	WIRE COLOR	DISCONNECT FROM TERM.
G	A of chute assem.	G	A of chute assem.
G	X of chute assem.	G	E of chute assem.
Y	E of chute assem.	Y	E of chute assem.
BR	BR of TB4	BR	BR of TB4

(2) Remove P-111877 screw and P-12A666 stop (Fig. 5)

(3) Loosen P-25E445 screw in lower left corner of chute assembly (Fig. 6). Exercise care not to lose P-12A681 spring located under screw head.

(4) Loosen two P-11E183 bayonet guides on chute assembly (Fig. 5).

(5) Lift gong signal and chute assembly off.

(6) Install, using reverse procedure.

Baffle and Hinge Assembly

2.05 To remove baffle and hinge assembly (Fig. 5):

(1) Disconnect all wires from TB4

(2) Remove retainer ring from rear of the coin release shaft.

(3) Remove four P-181641 screws, four P-285080 lockwashers and lift baffle and hinge assembly off.

(4) Install, using reverse procedure.

Dial and Housing Assembly

2.06 To remove dial housing:

(1) Remove coin twister assembly (2.03).

(2) Remove gong signal and chute assembly (2.04).

(3) Remove baffle and hinge assembly (2.05).

(4) Remove four mounting screws in dial housing.

(5) Lift dial housing off.

Note: Handset cord will pull through cover to enable access to dial without disconnecting cord.

(6) Install, using reverse procedure.

2.07 To remove dial:

Note: No field maintenance should be performed on the dial, replace if defective.

(1) Remove dial housing (2.06).

(2) Disconnect dial leads from TB2 (dial terminal board).

(3) Loosen two mounting screws on sides of dial through access holes in dial housing.

(4) Lift dial off.

2.08 To install dial:

(1) Use reverse procedure in 2.07 and make connections as follows:

235G		1235G	
WIRE COLOR	CONNECT TO	WIRE COLOR	CONNECT TO
Y	TB2-1	G	TB2-1
W	TB2-2	W	TB2-2
G	TB2-2	BL	TB2-3
BL	TB2-3	O-BK	TB2-4
W	TB2-9	R	TB2-5
Y	TB2-11	R-G	TB2-6
		O-R	TB2-8
		BK	TB2-11

Handset

2.09 To remove handset:

- (1) Remove gong signal and chute assembly (2.04).
- (2) Disconnect handset leads from TB4.
- (3) Loosen cord stay screw (Fig. 6).
- (4) Remove screw and cord clamp from armored cord.
- (5) Pull cord out front of cover.
- (6) Install, using reverse procedure.

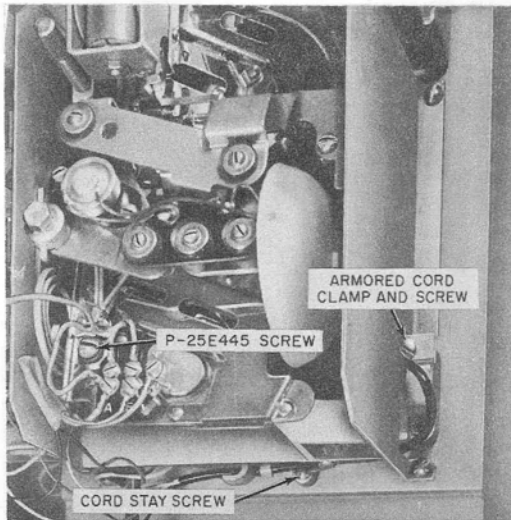

Fig. 6—Location of Cord Stay Screw and Cord Clamp

HOUSING ASSEMBLY**Ringer**

2.10 To remove ringer:

- (1) Disconnect ringer leads from TB3.
- (2) Remove two screws.

(3) Lift ringer up and off.

2.11 To install ringer:

- (1) Mount ringer in place and secure with two screws.
- (2) Connect ringer leads as follows:

<u>WIRE COLOR</u>	<u>CONNECT TO</u>
BK	TB3-R
R	TB3-T
S-R	TB3-A
S	TB3-K

Return Chute Assembly

2.12 To remove return chute assembly (Fig. 7):

- (1) Loosen mounting screw.
- (2) Lift assembly up and out.

Note: It may be necessary to remove P-28E453 clip.

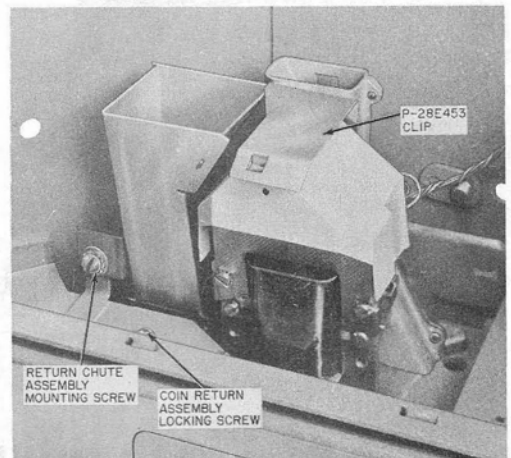

Fig. 7—Coin Relay and Return Chute Assembly

2.13 To install return chute assembly:

- (1) Slide the assembly in and down until it is properly seated.
- (2) Tighten the mounting screw.



If the return chute is not installed properly, there can be a gap between the return chute and the hopper assembly large enough to allow coins to drop into the housing. Refer to Fig. 8 for this gap. This gap may be observed by placing a light down the opening in the return chute, tripping the relay and hopper assembly to the reject position, and looking down the opening of the hopper assembly. Fig. 9 is a bird's eye view of what can be observed. If this gap exists, loosen the mounting screw and reposition

the return chute. Check again with a light (Fig. 9) and tighten screw when proper alignment is obtained.

Coin Relay

2.14 To remove coin relay (Fig. 7):

- (1) Remove return chute assembly (2.12).
- (2) Remove P-28E453 clip and dust cover.
- (3) Disconnect leads from coin relay.
- (4) Remove four screws and remove coin relay.

2.15 To install coin relay:

- (1) Place coin relay in position and secure with the four screws removed in 2.14(4).

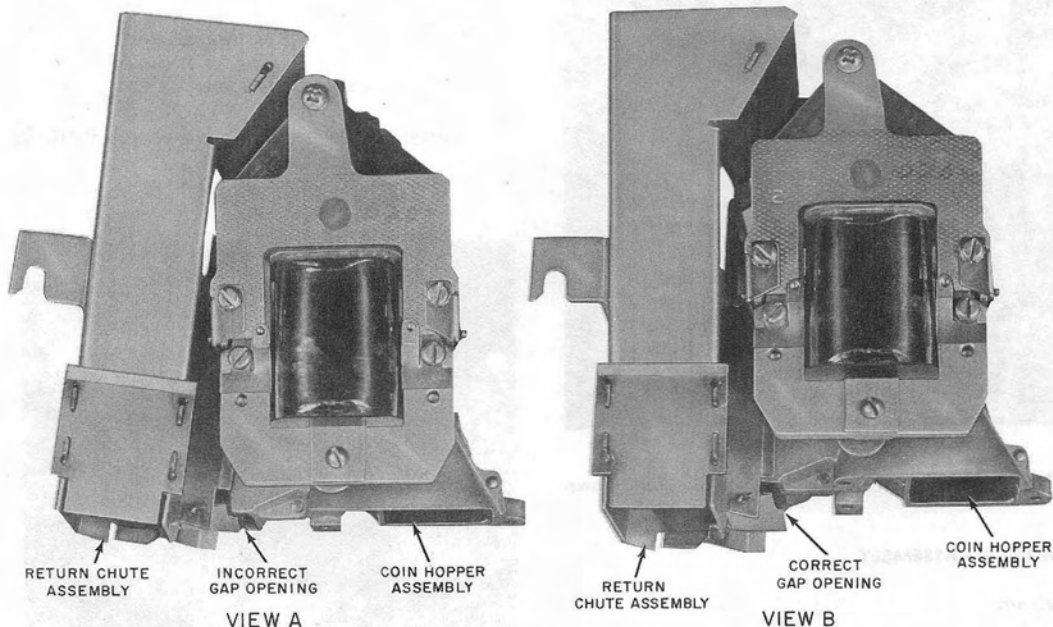

Fig. 8—Alignment of Return Chute Assembly

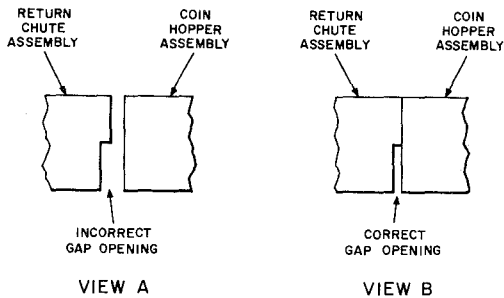

Fig. 9—Relative Position of Return Chute Assembly and Coin Hopper Assembly As Viewed Down Hopper Throat

- (2) Connect leads to coin relay as follows:

<u>WIRE COLOR</u>	<u>CONNECT TO</u>
R	1
R	2
G-Y	3
O	G

- (3) Install dust cover and P-28E453 clip (Fig. 7).
- (4) Install return chute assembly (2.12).

Coin Return Assembly

- 2.16** To remove coin return assembly:

- (1) Remove return chute assembly (2.11).

- (2) Remove coin return assembly locking screw (Fig. 7).
- (3) Insert finger in coin return and tilt top forward.
- (4) Lift coin return. Pull coin return assembly out and up.

- 2.17** To install coin return assembly:

- (1) Tilt top of coin return assembly toward set.
- (2) Push coin return assembly into set.
- (3) Push in and down on bottom of coin return assembly until flush with front of housing.
- (4) Install coin return assembly locking screw. Tighten screw only enough to hold return assembly in place. Further tightening will bend screw.
- (5) Install return chute assembly (2.12).

Coin Hopper

- 2.18** The coin hopper cannot be removed without removing 4A door and coin receptacle. If it becomes necessary to remove the coin hopper in the field, remove the 4A door and coin receptacle per local regulations.

3. CONNECTIONS

- 3.01** For connection information refer to Fig. 10 and 11.

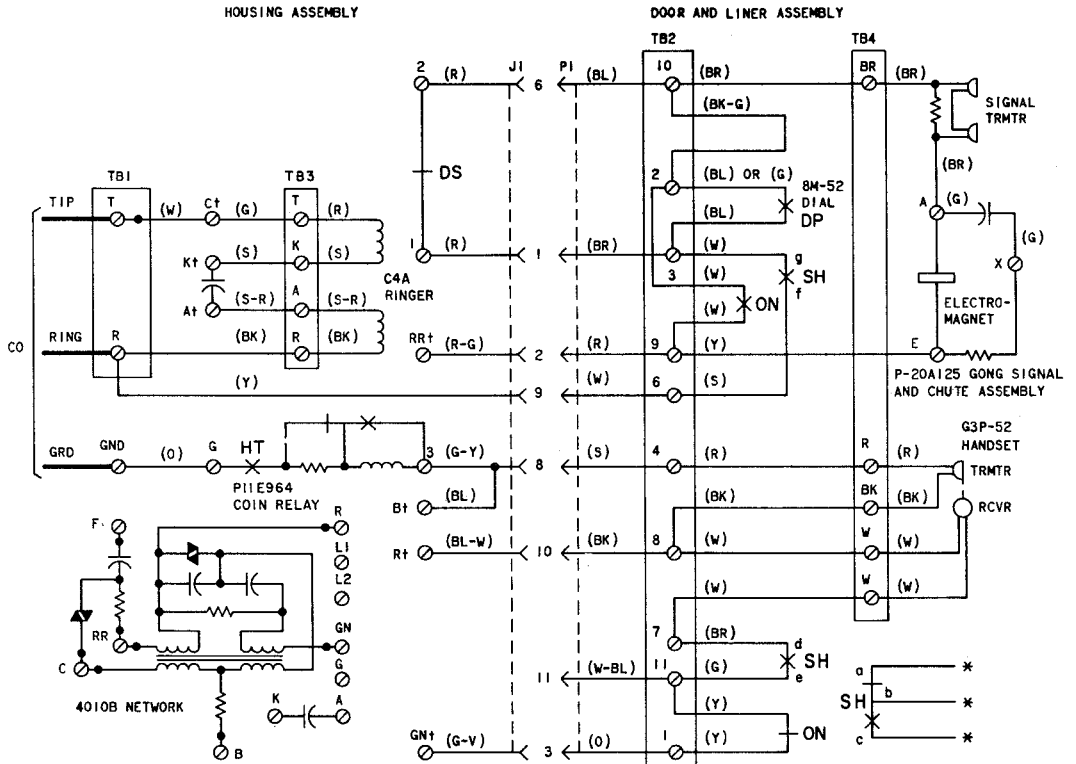

- * INSULATED AND STORED
- † NETWORK TERMINALS
- DS DIAL SHORTING CONTACTS
- DP DIAL PULSE CONTACTS
- HT HOPPER TRIGGER CONTACTS
- SH SWITCH HOOK CONTACTS
- ON OFF NORMAL CONTACTS

Fig. 10—235G Coin Collector, Connections

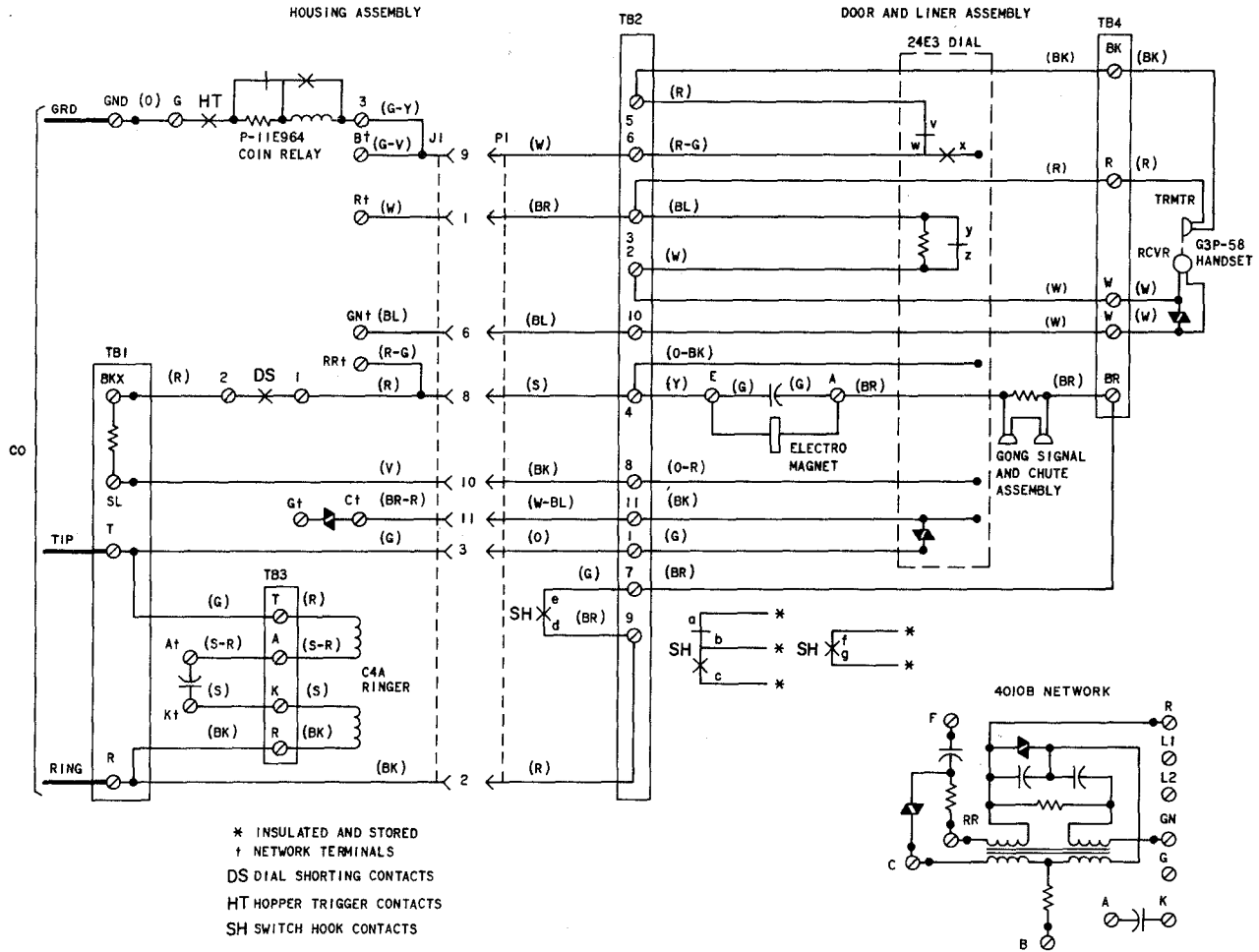

Fig. 11—1235G Coin Collector, Connections