

COIN TELEPHONE SHELF

KS-19267

ACOUSTIC ALUMINUM

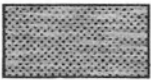

PLASTIC

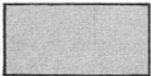

TRANSPARENT

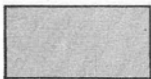

TRANSLUCENT

PORCELAIN ENAMEL

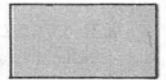

MEDIUM GRAY



DARK GRAY



LIGHT BLUE

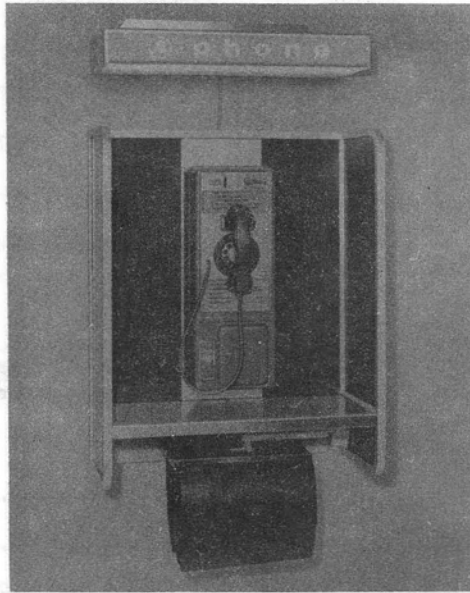

WOODGRAIN



BIRCH

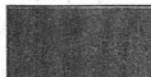

WALNUT



MAHOGANY



FRUITWOOD

Fig. 1—KS-19267 Coin Telephone Shelf and Available Finishes

1. GENERAL

1.01 Information in this section was formerly contained in Section 508-121-100 which is hereby canceled.

2. IDENTIFICATION

2.01 The KS-19267 coin telephone shelf (Fig. 1) is a wall mounted unit for indoor use only. It may be installed singly or in multiple and mounts either the 200-type coin collector or 1A/1C-type coin telephone set.

2.02 The basic shelf assembly includes:

- B-196775 mounting plate for coin collector/telephone set
- Metal frame assembly
- B-196771 writing shelf
- B-196770 backboard assembly for mounting the metal framework.

2.03 Overall dimensions of a single shelf are:

- Height—32 inches
- Width—25-1/2 inches
- Depth—12 inches.

2.04 The desired panels, directory rack, directory hanger, and other optional items are added to the basic shelf assembly as required. These are listed in Table A.

2.05 This shelf features replaceable back and side panels, which are available in a variety of colors and finishes (Fig. 1).

2.06 Illumination, if required, is furnished by a KS-19322 sign which must be ordered separately. It may be mounted directly to the wall surface above the coin telephone shelf or on the top edge of a KS-19267, List 10 auxiliary backboard if the sign and shelf are to be installed as one unit.

2.07 Telephone directories may be placed under the writing shelf in a rack (Fig. 2) or in a KS-20030 directory hanger (Fig. 1).

Ordering Information

2.08 When ordering specify the quantity, KS number, and list number of each item required including those that must be ordered separately.

2.09 The following are examples of typical orders:

Example 1

Single installation for 1A/1C-type coin telephone set with fruitwood grain panels and directory hanger.

- 1—Shelf, KS-19267, List 1
- 2—Panels, KS-19267, List 23
- 2—Panels, KS-19267, List 33
- 1—Directory Hanger, KS-20030, List 1
- 1—Mounting Bracket, KS-19267, List 14

Example 2

Single installation for 200-type coin collector with acoustic panels, directory rack, illuminated sign, and auxiliary backboard.

- 1—Shelf, KS-19267, List 1
- 1—Panel, KS-19267, List 45
- 1—Panel, KS-19267, List 46
- 2—Panels, KS-19267, List 47
- 1—Rack, KS-19267, List 11
- 1—Mounting, Subscriber Set, KS-19267, List 12
- 1—Backboard, KS-19267, List 10
- 1—Sign, KS-19322, List 1

Example 3

Three shelves in a multiple installation, for 1A/1C-type coin telephone set, with blue panels, two directory hangers each, and one illuminated sign mounted directly to wall above shelves.

- 1—Shelf, KS-19267, List 2

TABLE A
KS-19267 COIN TELEPHONE SHELF
ORDERING GUIDE

LIST NUMBER	DESCRIPTION	REMARKS	
1	Basic Shelf Assembly	For single installation	
2		For multiple installation — left end	
3		For multiple installation — right end	
4		For multiple installation — center	
10	Auxiliary Backboard	For mounting KS-19322 sign and shelf as one unit	
11	Directory Rack	Mounts under shelf (Fig. 2)	
12	Mounting, Subscriber Set	For 200-type coin collector (Fig. 3)	
13	Cover Assembly	Mounts under shelf in place of directory rack (Fig. 4)	
14	Mounting Bracket	For mounting KS-20030, List 1 or List 2 directory hanger under shelf (Fig. 5)	
15		For mounting subset under shelf when KS-20030 directory hanger is used (Fig. 6)	
20	Panel, Side	Laminated	Birch grain
21			Walnut grain
22			Mahogany grain
23			Fruitwood grain
26		Porcelainized	Light blue
27			Medium gray
28			Dark gray
30			Panel, Back
31	Walnut grain		
32	Mahogany grain		
33	Fruitwood grain		
36	Porcelainized	Light blue	
37		Medium gray	
38		Dark gray	
40		Panel, Side	
41	Translucent		
45	Panel, Acoustic	Right side	
46		Left side	
47		Back	
48		Center	

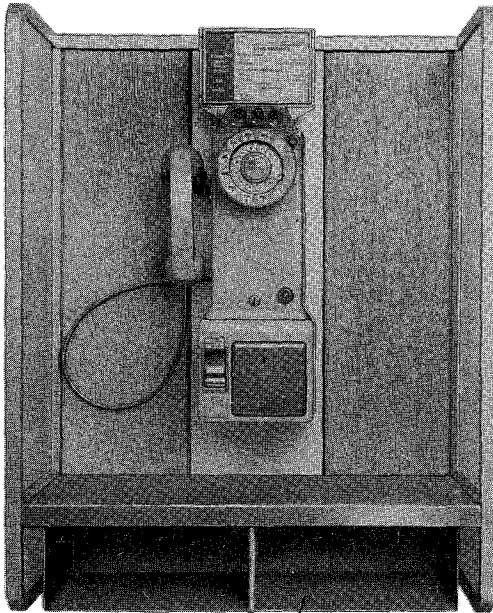

KS-19267, L11
DIRECTORY RACK

**Fig. 2—KS-19267 Coin Telephone Shelf With KS-19267,
List 11 Directory Rack**

- 1—Shelf, KS-19267, List 3
- 1—Shelf, KS-19267, List 4
- 4—Panels, KS-19267, List 26
- 6—Panels, KS-19267, List 36
- 3—Directory Hangers, KS-20030, List 2
- 3—Mounting, Bracket, KS-19267, List 14
- 1—Sign, KS-19322, List 1

3. INSTALLATION

3.01 Ensure that location specified on service order corresponds to customer's wishes. Also verify that the following conditions are met:

- Location is free of hazards

- Shelf will be easily accessible to the public
- Location will provide a secure mounting for shelf
- If lighted sign is to be installed, be sure 3-wire grounded outlet is provided
- Ground is present at receptacle.



The B-196770 backboard assembly can be installed directly on a wall if the surface permits. If a lighted sign is to be used, it is desirable to mount the shelf and light on a KS-19267, List 10 auxiliary backboard as one unit.

3.02 To install either the List 10 auxiliary backboard or the B-196770 backboard assembly on a wall, refer to Section 506-100-101 and observe the following:

Note 1: Holes are not provided in the List 10 backboard for surface mounting. The nine mounting holes in the B-196770 backboard are for securing it to the auxiliary backboard; however they may be used for surface mounting if wall permits.

Note 2: At least nine fasteners must be provided for securing the backboard to a wall. The wall studs, construction, and surface determines where additional holes are drilled; however, when installing the auxiliary backboard, fasteners should be omitted from the area between top of shelf and bottom of lighted sign.

Note 3: When providing mounting holes in the B-196770 backboard, countersink the nine holes to ensure that screw heads will be underflush when installed, otherwise there may not be sufficient clearance to slide the rear shelf panel up in place.

Note 4: Locate backboard(s) with bottom edge 35-1/4 inches from floor. In multiple installations, backboards shall be 24-3/4 inches from center to center.

3.03 Secure B-196770 backboard assembly to List 10 auxiliary backboard, if applicable, using nine 1/4-20 by 1-1/2 FHM screws (Fig. 7).

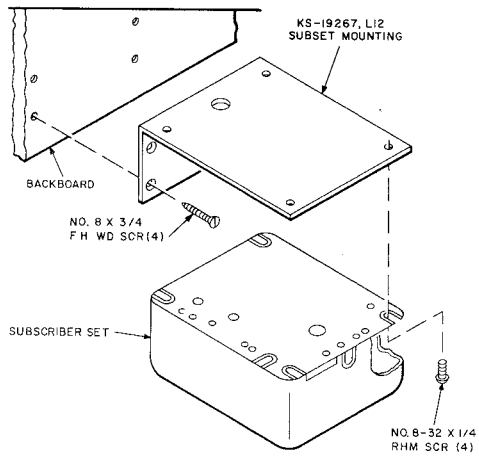

A
METHOD FOR MOUNTING
WITHOUT DIRECTORY RACK

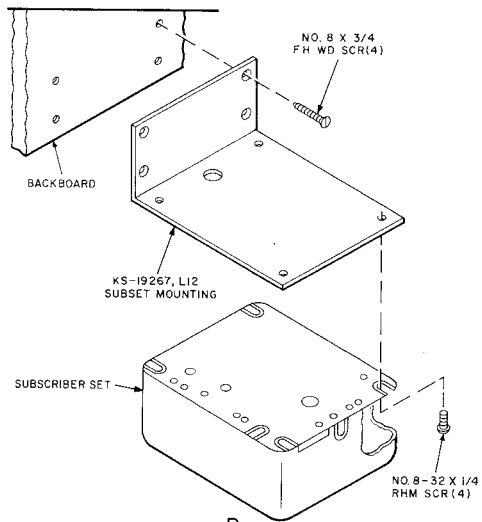

B
METHOD FOR MOUNTING
WITH DIRECTORY RACK

Fig. 3—KS-19267, List 12 Subscriber Set Mounting

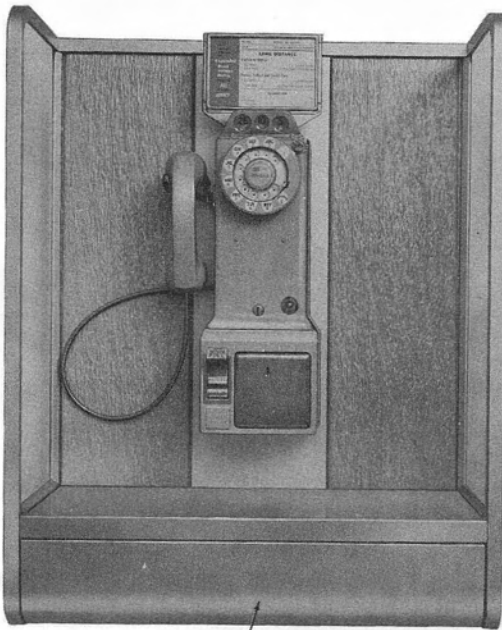

KS-19267, L13
COVER ASSEMBLY

Fig. 4—KS-19267 Coin Telephone Shelf With KS-19267, List 13 Cover Assembly

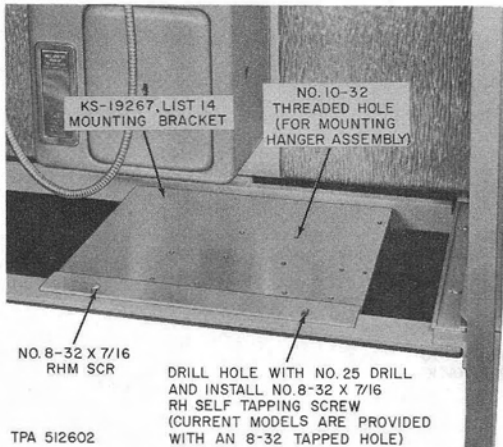

TPA 512602

Fig. 5—KS-19267, List 14 Mounting Bracket Installed

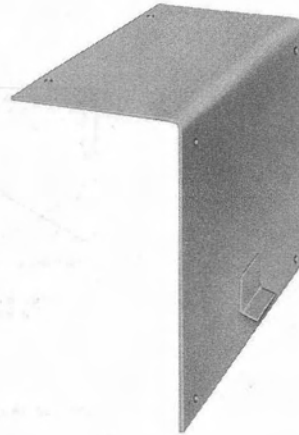

Fig. 6—KS-19267, List 15 Subset Mounting Bracket

3.04 Install KS-19322 sign if applicable and cover exposed electric power cord between sign and shelf with KS-19322, List 16 wire shield (Fig. 7).

3.05 Install telephone wiring.

3.06 Install B-196762-1 and -2 side columns on backboard using two No. 10-32 by 9/16 FHM screws in each column.



Where multiple units are installed, a B-196772 T-strip will be used to join two shelves together. This T-strip will replace the side column. T-strips are furnished as part of KS-19267, List 2 and List 4 shelf assemblies (Fig. 7).

3.07 Place frame assembly against backboard so that side rails fit into side columns or T-strips, and top cross rail rests partially on top edge of backboard.

3.08 Secure frame assembly to backboard using two 1/4-20 by 7/8 FHM screws and six 1/4-20 by 3/4 FHM screws.

3.09 Secure coin collector/telephone set mounting plate to backboard assembly using six 1/4-20 by 1-1/4 FHM screws.

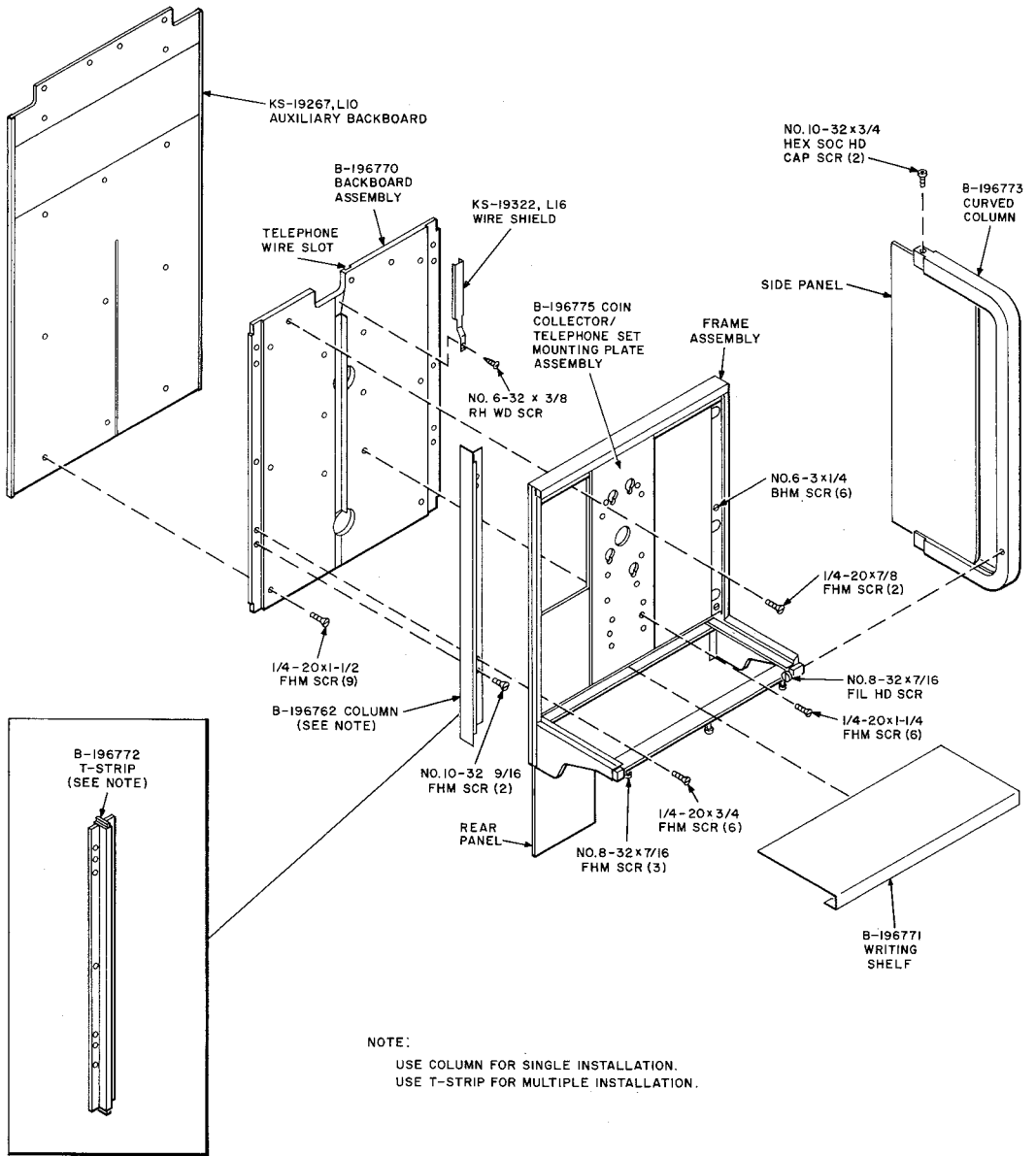

Fig. 7—Assembly of KS-19267 Shelf

SECTION 508-251-100

3.10 Insert side panels into curved columns. Place curved columns into slots on top and bottom edge of shelf assembly and secure with No. 10-32 by 3/4 hex socket head cap screws.

3.11 Further secure curved columns at front of shelf using No. 8-32 by 7/16 fillister head screws.

3.12 Loosen the No. 6-32 by 1/4 binding head screws in rails adjacent to side panels. Force rails tight against panels and tighten screws. This will prevent panels from rattling.

3.13 If a KS-20030, List 1 or List 2 directory hanger is used, install mounting bracket at this time. Refer to Section 508-710-102 and Fig. 5.

3.14 Insert B-196771 writing shelf in slots provided and slide toward backboard until almost seated.

3.15 Refer to Note 3 in 3.02. Insert back panels as shown, and slide them all the way to the top. Slide writing shelf all the way in and release back panels so that they rest on top of back edge of writing shelf.

3.16 If no KS-19267, List 11 directory rack nor KS-19267, List 13 cover assembly is used, secure writing shelf to frame assembly using three No. 8-32 by 7/16 fillister head screws.

3.17 If a subscriber set is required, mount under the writing shelf as shown in Fig. 3 using a KS-19267, List 12 subscriber set mounting, or using a KS-19267, List 15 mounting bracket if a KS-20030 directory hanger is used.

3.18 Install KS-19267, List 11 directory rack per Fig. 8.

3.19 Install KS-19267, List 13 cover assembly per Fig. 9.

3.20 To add additional shelves to existing installations:

(a) Remove List 11 directory rack or List 13 cover assembly if applicable.

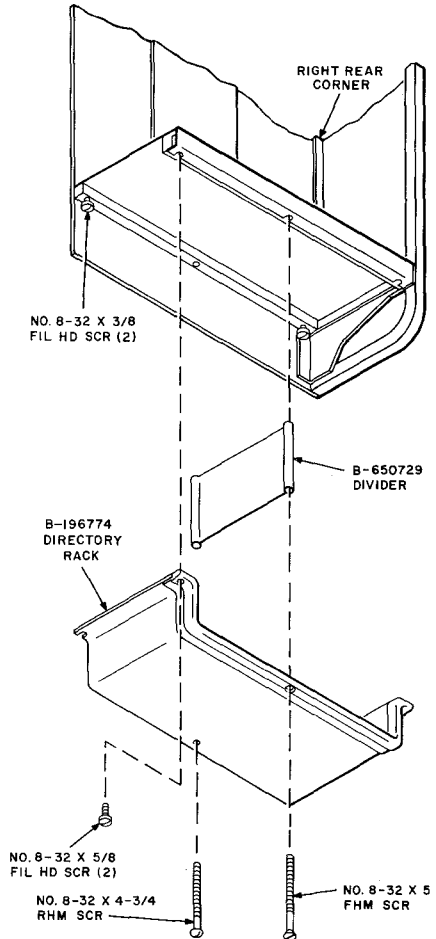

Fig. 8—Installation of KS-19267, List 11 Directory Rack

(b) Remove the following per Fig. 7:

- Writing Shelf
- Curved Column
- Side Panel
- Rear Panel.

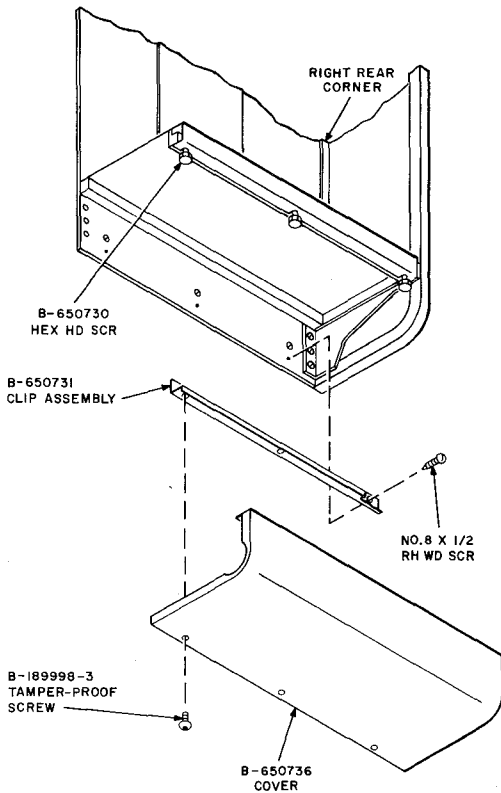

Fig. 9—Installation of KS-19267, List 13 Cover Assembly

(c) Remove the following per Fig. 10:

- B-196769 Rail
- B-196765 Strip
- B-196762 Column.

(d) Install B-196772 T-strip where B-196762 column was removed.

(e) Install B-196765 strip in its original position.

(f) Reassemble all parts in reverse order as outlined in (a) through (c) except omit the B-196762 column.

(g) Perform operations outlined in 3.02 through 3.19 for each additional shelf installed.



Ensure that the curved column, which is common between two shelves, has a hole on each side at writing shelf level.

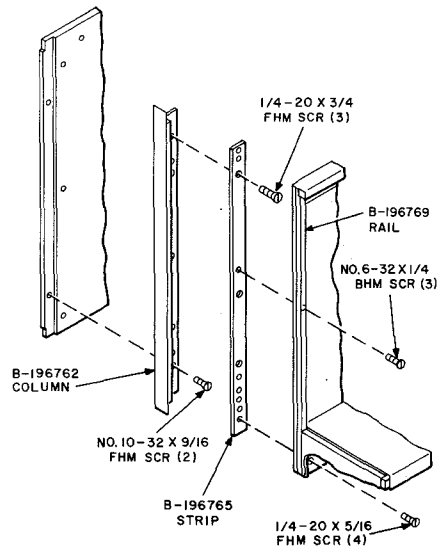

Fig. 10—Partial View of Shelf Assembly

4. MAINTENANCE

4.01 The local telephone company shall establish the appearance standards of all exposed surfaces.

4.02 The local telephone company shall establish the safety standards for all coin telephone shelves.

4.03 Inspect the approach to the shelf and ensure that it is free of all hazards.

SECTION 508-251-100

- 4.04** Ensure that all visible assembly screws are secure.
- 4.05** Refer to Section 508-100-101 for information on cleaning of shelf.
- 4.06** Refer to Fig. 7, 8, and 9 and Tables A and B for replacement parts.

TABLE B
MISCELLANEOUS REPLACEMENT PARTS

NAME	PART NUMBER	DESCRIPTION
T-Strip	B-196772	Used in place of columns to convert single installations to multiple
Curved Column	B-196763-1	Center (multiple installations)
Curved Column	B-196763-2	Right side
Curved Column	B-196763-3	Left side
Column	B-196762-1	Right side
Column	B-196762-2	Left side