

## TELEPHONE BOOTH

### KS-19580 AIRLIGHT II AND IIA

#### 1. GENERAL

1.01 This section includes identification, installation, and maintenance information.

1.02 This section is reissued to:

- Change title
- Add information on the KS-19580, List 1A modified booth
- Add information on KS-19580, List 102 multiple kit

#### 2. IDENTIFICATION

2.01 The KS-19580, List 1 booth (Fig. 1) is an outdoor aluminum and glass telephone booth designed for single or multiple side-by-side installations. It is available in polished aluminum (List 60), gold (List 61), and bronze (List 62).

2.02 ♦The KS-19580, List 1A booth (Fig. 1) is a modification of the basic booth. The doors and seat have been removed, the entrance widened, the shelf lowered, and the coin telephone set lowered to the universal coin slot height of 54 inches.♦

2.03 The overall dimension of these booths are:

- Height—83-1/8 inches (less rain bead)
- Width—33-1/2 inches
- Depth—33-1/2 inches (front sign projects 1-1/2 inches beyond this dimension)

2.04 When provided, the door consists of two vertical sections, each containing a full length safety glass panel. It is self-closing and folds along the right wall when opened.

#### PANELS

2.05 Door, side, rear, and bottom panels are available as described in Table A. Sign panels are available as described in Table B.

#### ILLUMINATION AND VENTILATION

2.06 Unless otherwise specified, the booth is illuminated by a KS-19207, List 7 light fixture which also illuminates the signs. See Section 508-820-100.

2.07 When doors exist, ventilation is provided through an opening in the front sign and also through screened louvered panels which may be installed at the sides and rear in place of a sign.

2.08 In a List 1 booth where additional ventilation is required, a KS-19207, List 3 light and blower unit can be used; this unit must be ordered separately plus the following associated items:

- B-650927 switch assembly
- B-650929 actuator switch
- B-684779 switch assembly
- B-553806-2 switch housing
- Two 8-32 by 1/4 Phillips RH self-tapping screws
- Two 8-32 by 1/2 Phillips RH self-tapping screws

**Note:** The B-684779 wall mounted switch permits the customer to turn the blower on and off as desired. This switch is used in conjunction with the B-650927 door operated switch.

#### NOTICE

Not for use or disclosure outside the  
Bell System except under written agreement

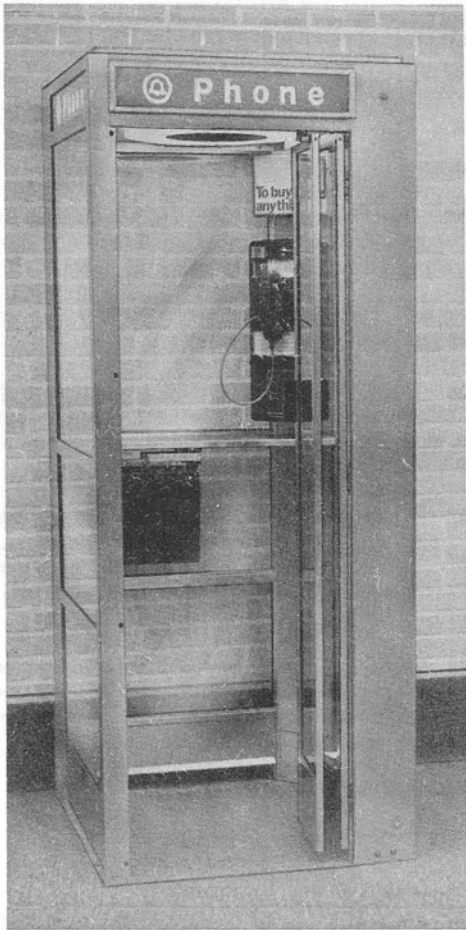

LIST I (BASIC) BOOTH

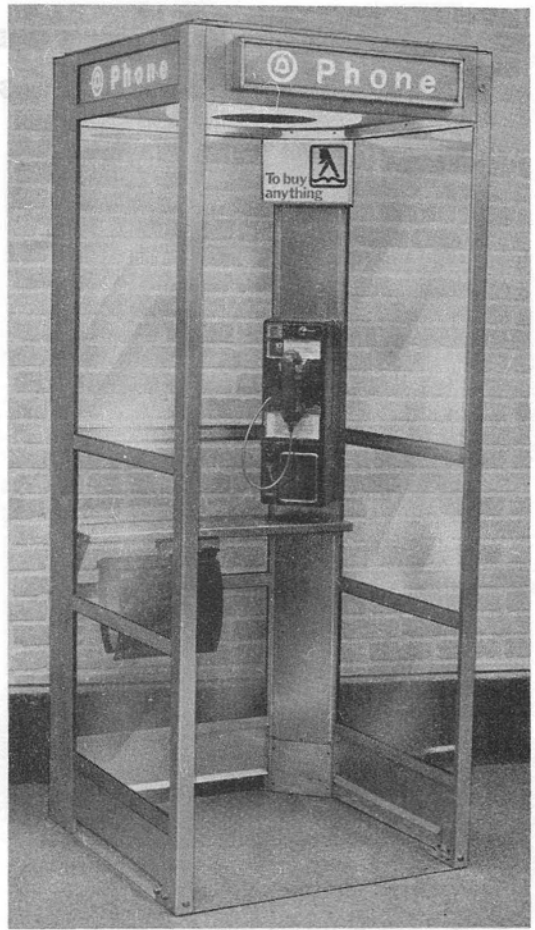

LIST IA (MODIFIED) BOOTH

Fig. 1—KS-19580 Booth

2.09 A booth may be equipped with a KS-19261, List 1 light control unit. In multiple installations, a maximum of five booths may be interconnected and controlled by one light control mounted in the end booth of the row.

2.10 Refer to Section 508-825-100 for complete information on the KS-19261 light control unit.

2.11 In multiple installations, a KS-19580, List 51 receptacle assembly (Fig. 2) must be used in conjunction with a KS-19261 light control unit as follows:

- (a) One receptacle is required for **each multiple installation** where KS-19207, List 7 light fixtures are used.

◆ TABLE A ◆

## DOOR, SIDE, REAR, AND BOTTOM PANELS

KS-19580 LIST NO. OR PART NO.	DESCRIPTION	REMARKS	
10	Side or Rear Panels, Tempered Glass	7/32-inch thick small panel	
12		7/32-inch thick large panel	
14	Door Panel, Tempered Glass	7/32-inch thick (List 1 booth only)	
32	Side or Rear Aluminum Panels*	Small side or rear panel	
33		Large side or rear panel	
B-994928	Bottom Aluminum Panels*	Short right side panel (List 1A booth only)	
B-994927		Solid right side panel (List 1A booth only)	
38		Short right side panel (List 1 booth only)	
39		Short rear panel with tie down angle	
40		Solid right side panel (List 1 booth only)	
41		Solid rear panel with tie down angle	
49		Solid left side panel	
50		Short left side panel	
90		Porcelain Enamel Panels	Large side or rear panel
91	Gray		
92	Red		
93	Small side or rear panel		Blue
94			Gray
95			Red

\* Available in Polished Aluminum (List 60), Gold (List 61), and Bronze (List 62).

TABLE B  
SIGN PANELS

KS-19580 LIST NO.	COLOR		REMARKS
	LETTERS	BACKGROUND	
16	None	Aluminum Solid Panel	Used on sides and rear in place of telephone sign
35		Aluminum Louvered Panel	Used on sides and rear to increase ventilation of booth
72*	White	Blue	Front sign
75	Blue	White	
80*	White	Blue	Rear and side signs
84	Blue	White	
86	None	Blue	Front sign
87		White	
88		Blue	Rear and side signs
89	White		

\* KS-19580, List 72 and List 80 signs are furnished unless otherwise specified.

(b) One receptacle is required for *each booth* in a multiple installation where KS-19207, List 3 light and blower units are used.

2.12 A mounting bracket (Fig. 3) is provided in ceiling area for mounting a List 51 receptacle.



Fig. 2—KS-19580, List 51 Receptacle Assembly

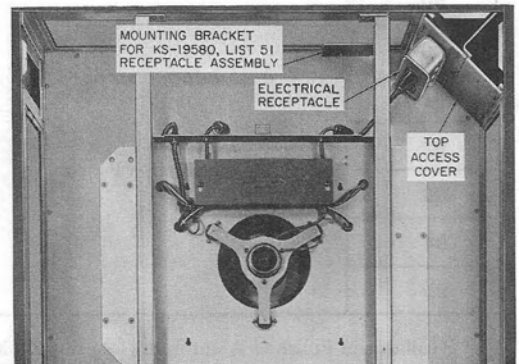

Fig. 3—KS-19580 Booth Ceiling Area

#### WIRING

#### Electric Wiring

2.13 Use one of the following:

- (a) **KS-19580, List 30 power cord assembly (Fig. 4):** Used for overhead power.
- (b) **KS-19580, List 31 power cord group (Fig. 5):** Used for ground level entrance where a circuit breaker is not required.
- (c) **KS-19425, List 24 power cable assembly (Fig. 6):** Used to bring power from the KS-19426, List 17 circuit breaker box to the electrical receptacle (Fig. 3) located above the ceiling.



**If a circuit breaker is required, order following items separately:**

- Hineman Electric Co. No. 0912 circuit breaker, catalog No. 91-106-1
- KS-19426, List 17 circuit breaker box (Fig. 7)
- Two No. 8-32 by 3/8 Phillips RHM screws
- Two No. 8-32 Hex nuts.

**Note:** Hex nuts are not required on current production booths.

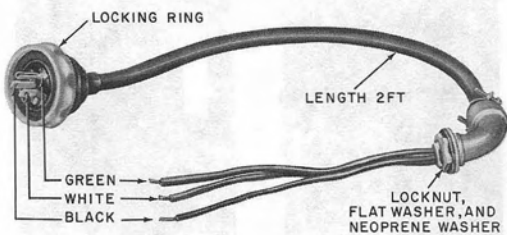

Fig. 4—KS-19580, List 30 Power Cord Assembly

### Telephone Wiring

2.14 The telephone wire will terminate above the ceiling on a 123A1A protector which is furnished with the booth and located behind the top access cover (Fig. 3).

- On older model booths, the top access cover is secured with screws.
- On current models, the top access cover is equipped with key hole slots for convenient access.
- On all models the protector can be moved down behind the bottom access cover.

2.15 The booth is wired for coin telephone set connections.

### CARD FRAME

2.16 Booth will accept a KS-19928, List 2 card frame. Refer to Section 508-811-100.

### DIRECTORY HANGER, RACK, AND SHELF ARRANGEMENTS

2.17 Unless otherwise specified, a KS-19580, List 29 shelf assembly is furnished with each booth (Fig. 8). The List 29 shelf will accept a KS-20030, List 1 or List 2 directory hanger; order separately.

2.18 Refer to Fig. 9 for optional shelf arrangements which can be used in the List 1 booth.

### SEAT ASSEMBLY (List 1 Booth Only)

2.19 This booth is designed primarily for standup service; however, a KS-19425, List 11 seat assembly can be used if desired (Fig. 10). Order seat assembly and KS-19425, List 12 mounting plate separately when required.

### FLOOR

2.20 Unless otherwise specified, an aluminum tread floor is furnished.

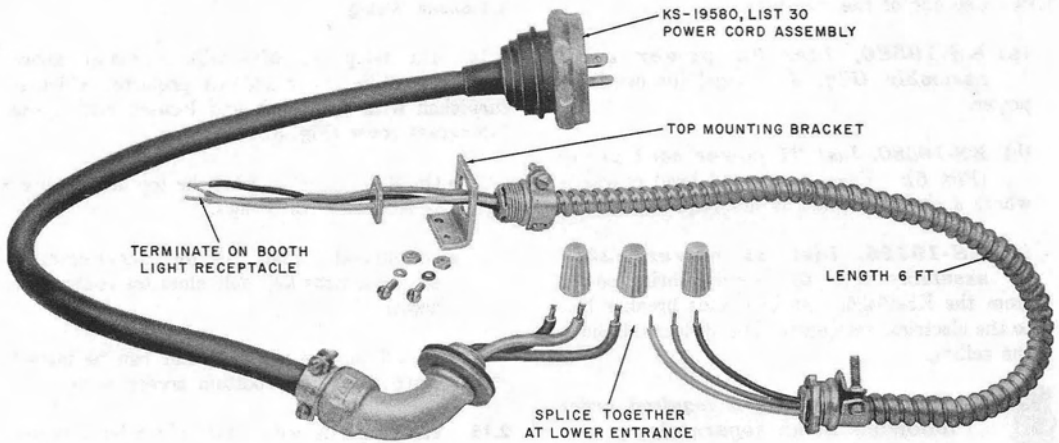

Fig. 5—KS-19580, List 31 Power Cord Group

CIRCUIT BREAKER:  
HEINEMAN ELECTRIC CO.  
NO. 0912, 120 VOLT AC,  
15 AMP, CURVE 3,  
SINGLE POLE (CAT NO. 91-106-1)

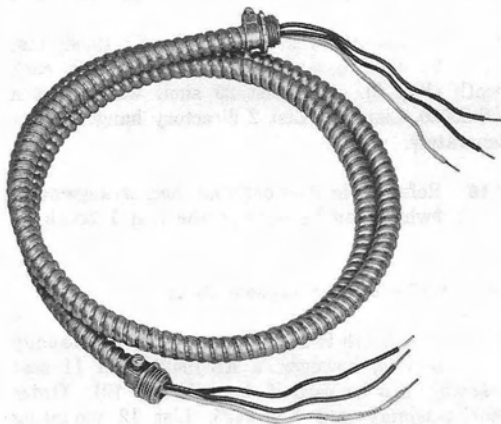

Fig. 6—KS-19425, List 24 Power Cable Assembly

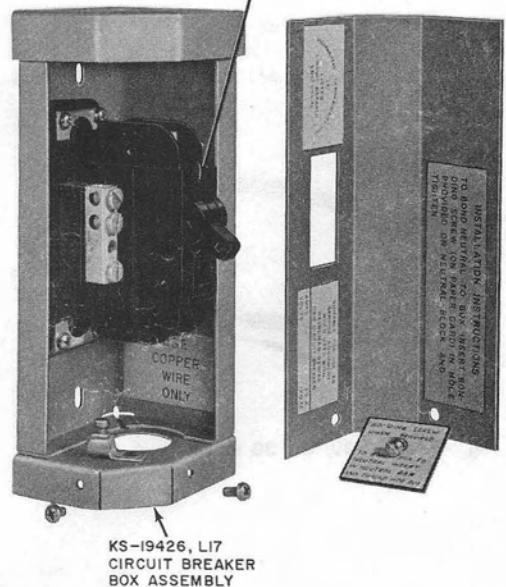

Fig. 7—Circuit Breaker and Box Assembly

**LEVELING DEVICES**

2.21 Adjustable mounting angles are provided to facilitate booth leveling up to 3 inches (Fig. 11). They are also used for bolting the booth to its mounting surface.

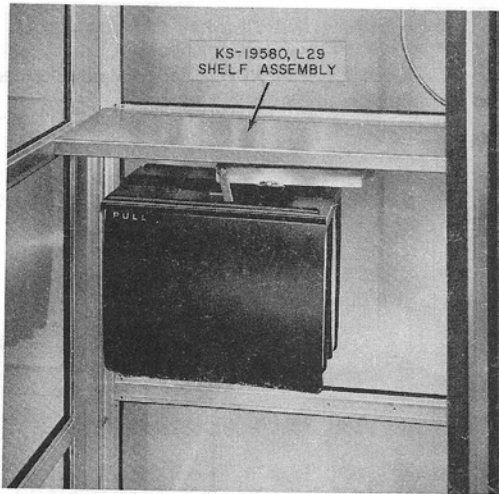

Fig. 8—KS-19580, List 29 Shelf Assembly with KS-20030, List 2 Directory Hanger (Typical)

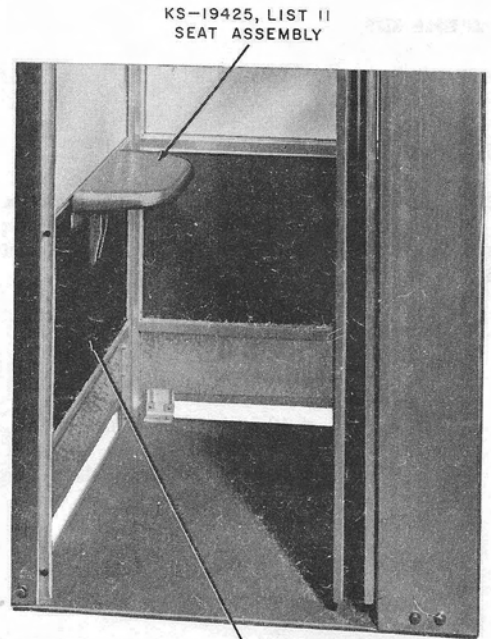

Fig. 10—KS-19425, List 11 Seat Assembly with KS-19425, List 12 Mounting Plate

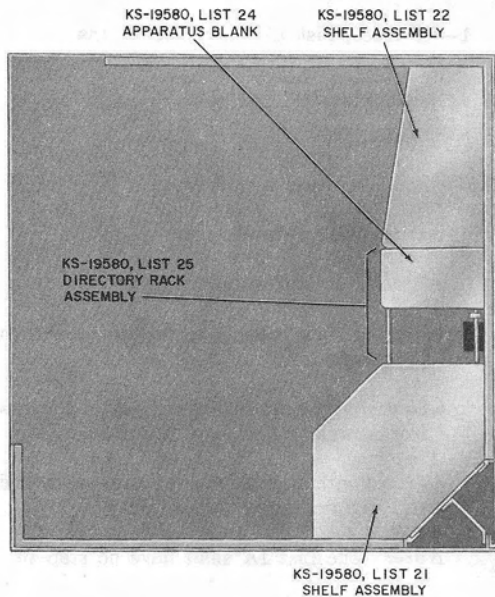

Fig. 9—Rear Wall Shelf Arrangement

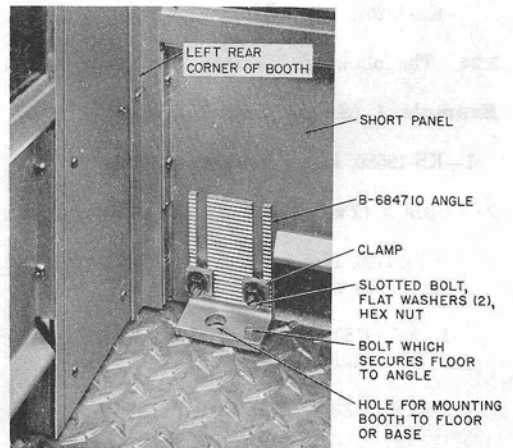

Fig. 11—Anchor Bracket and Leveling Device

**MULTIPLE KITS**

2.22 Refer to Fig. 12 and 13.

**ORDERING GUIDE**

2.23 A standard booth is available which can be ordered as a KS-19580, List 1 booth without specifying additional list numbers. It has a List 60 finish and is equipped as follows:

- 1—KS-19580, List 72 Sign Panel
- 3—KS-19580, List 80 Sign Panels
- 3—KS-19580, List 12 Large Side Panels
- 2—KS-19580, List 14 Glass Door Panels
- 6—KS-19580, List 10 Small Side Panels
- 1—KS-19580, List 38 Bottom Panel With List 60 Finish
- 1—KS-19580, List 39 Bottom Panel With List 60 Finish
- 1—KS-19580, List 50 Bottom Panel With List 60 Finish
- 1—KS-19580, List 29 Shelf Assembly
- 1—KS-19207, List 7 Light Fixture

2.24 The following are examples of typical orders.

**Example 1 (Single List 1 booth):**

- 1—KS-19580, List 1 Telephone Booth

**Example 2 (Two List 1 booths plus options):**

- 2—KS-19580, List 1 Telephone Booths with List 61 finish consisting of:
  - 1—KS-19580, List 20 Multiple Kit with KS-19580, List 61 Finish
  - 2—KS-19580, List 75 Sign Panels
  - 4—KS-19580, List 84 Sign Panels
  - 5—KS-19580, List 12 Large Side Panels

- 5—KS-19580, List 10 Small Side Panels
- 5—KS-19580, List 93 Small Porcelain Enamel Panels
- 4—KS-19580, List 14 Glass Door Panels
- 2—KS-19580, List 40 Bottom Panels with List 61 Finish
- 2—KS-19580, List 41 Bottom Panels with List 61 Finish
- 2—KS-19580, List 49 Bottom Panels with List 61 Finish
- 1—KS-19261, List 1 Light Control
- 2—KS-19580, List 51 Receptacle Assemblies
- 2—KS-19425, List 22 Cable Assemblies
- 1—KS-19580, List 30 Power Cord Assembly
- 2—KS-19580, List 28 Foundation Templates

**◆Example 3 (List 1A booth):**

- 1—KS-19580, List 1A Telephone Booth◆

**3. INSTALLATION**

3.01 Booth location should be:

- Within full view of public
- Readily accessible to customer
- Free of such hazards as broken or uneven pavements
- Spaced with a minimum clearance of 6 inches from property lines and buildings
- Placed with as little step-up as possible and still maintaining proper drainage.

**Note:** The List 1A shall have no step-up.

3.02 The KS-19580 booth requires anchoring at all installations.



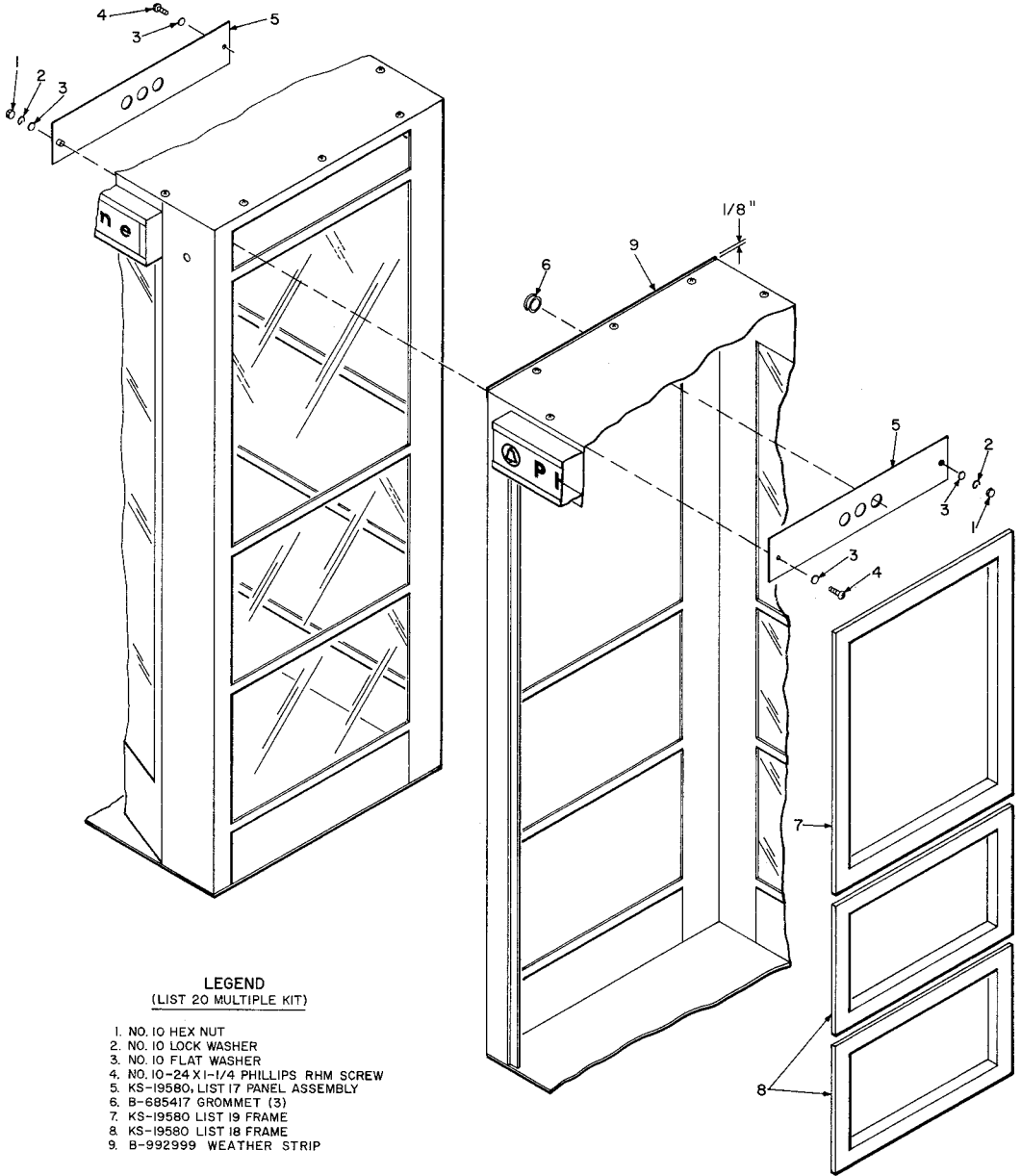

Fig. 12—KS-19580, List 20 Multiple Kit

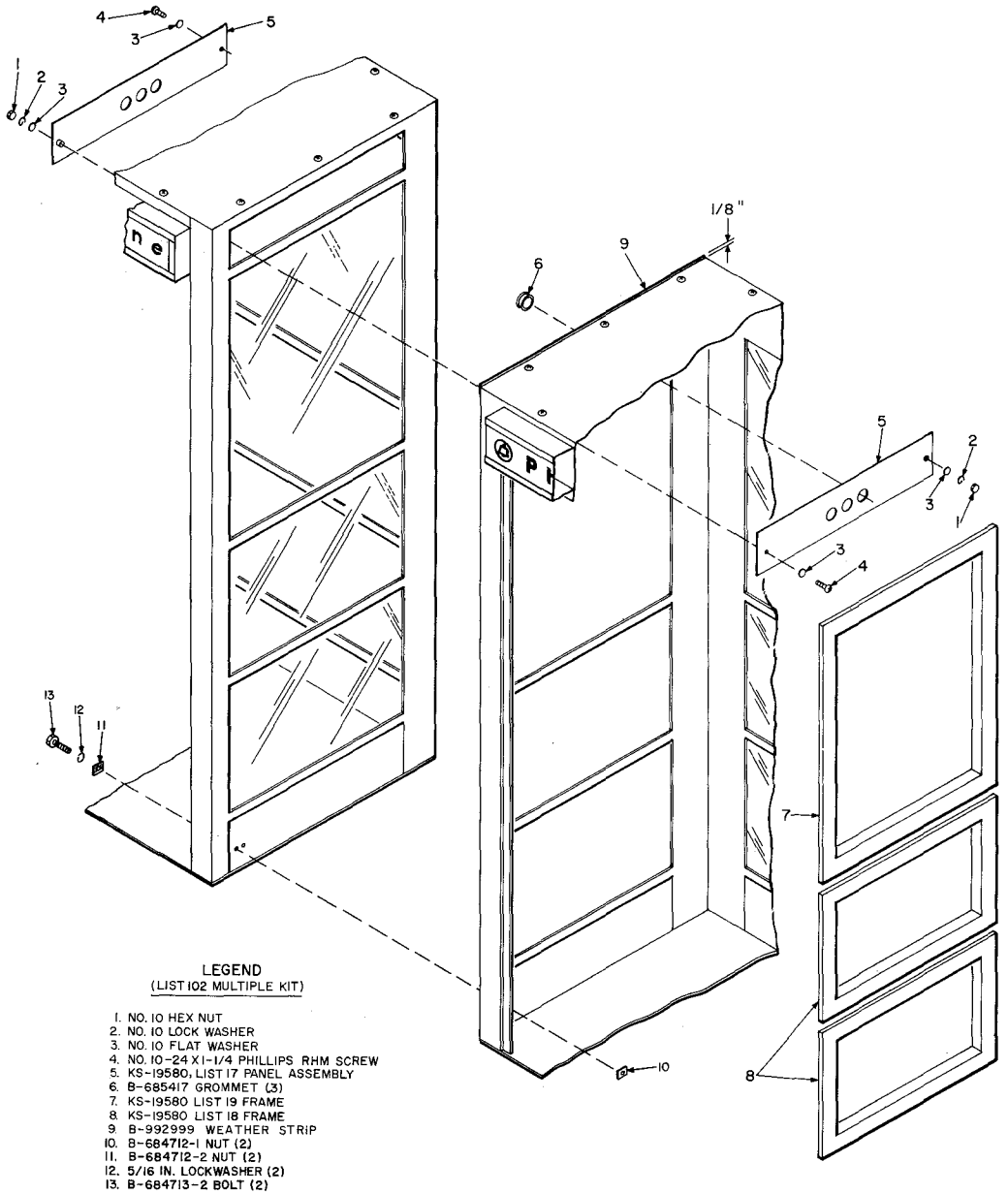

Fig. 13—KS-19580, List 102 Multiple Kit

## INSTALLATION OF FOUNDATION TEMPLATE

**3.03** When necessary to provide a concrete base, a KS-19580, List 28 foundation template (Fig. 14) is used. Install the Template as follows:

- (a) Prepare a form 40 inches square with an inside depth of 10 inches (Fig. 15).
- (b) Tamp 6 inches of cinders or gravel in the bottom of form.
- (c) Position the template in the form on wooden blocks so that the top of four mounting inserts will be flush with concrete base as shown in Fig. 14.



*Nail holes are provided in the four corners of the template for fastening the wooden blocks. Use the blocks to level and support the template at the proper height.*

- (d) If underground power and telephone wires are to be used, provide for holes in the concrete base at the positions of corresponding holes in the template.



*Do not remove screw plugs from booth mounting inserts until booth is installed. Their sole purpose is to prevent dirt from filling mounting holes.*

- (e) Pour concrete around the template to fill the form.
- (f) For multiple booth installations, where no separation between booths is required, fasten adjacent templates together with two 10-32 by 1/2 RHM screws and two No. 10 hex nuts.
- (g) For multiple booth installations, where separation of booths is required, fasten adjacent templates together with steel straps fabricated locally and No. 8 sheet metal screws.
- (h) For each additional booth, lengthen the form by approximately 33-1/2 inches.

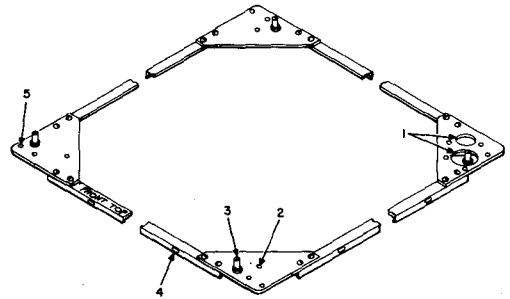

- LEGEND:
1. HOLES FOR UNDERGROUND TELEPHONE AND POWER WIRE ENTRANCE.
  2. NAIL HOLES FOR ATTACHING TEMPLATE TO LEVELING BLOCKS.
  3. BOOTH LEVELING INSERT.
  4. HOLES FOR FASTENING TWO TEMPLATES TOGETHER WHERE SEPARATION IS NOT REQUIRED.
  5. HOLES FOR FASTENING STEEL STRAPS WHERE SEPARATION OF TEMPLATES IS REQUIRED.

Fig. 14—KS-19580, List 28 Foundation Template

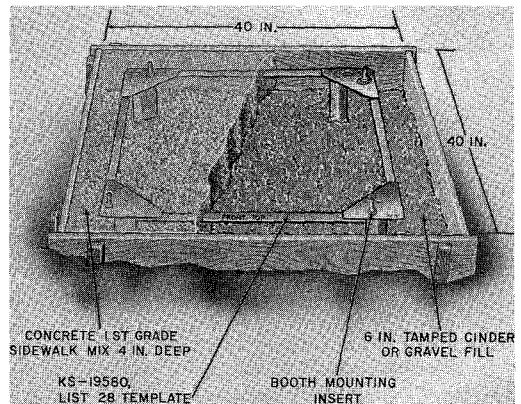

Fig. 15—Concrete Base Preparation with KS-19580, List 28 Template

## INSTALLATION OF BOOTH

**3.04** Secure booth as follows:

- (a) If a KS-19580, List 28 foundation template is used, remove insert plugs from template and secure anchor brackets (Fig. 11) of booth

to template using four 3/8-16 by 1-1/4 hex head bolts, four 3/8-inch lockwashers and four 3/8-inch flatwashers.

(b) If a KS-19580, List 28 foundation template is not used, and the booth is to be mounted on concrete, perform the following operations:

**Note:** On a List 1 booth, the right-front mounting bracket is attached to the front wall. On a List 1A booth, the right-front mounting bracket is attached to the right side bottom panel. Drill anchor holes accordingly.

- (1) Mark the locations for four mounting holes.
  - (2) Drill four 5/8-inch diameter holes to accept 3/8-inch machine bolt anchors for bolts.
  - (3) Install the fasteners.
  - (4) Secure anchor brackets of booth to bolt anchors using four 3/8-16 (length required) hex head bolts, four 3/8-inch lockwashers, and four 3/8-inch flatwashers.
- (c) If booth is to be mounted on a wooden floor, perform the following operations:
- (1) Mark the location for four mounting holes.
  - (2) Drill four lead holes to accommodate 5/16 by 2-1/2 inch lag screws.
  - (3) Secure booth to floor using the four 5/16 by 2-1/2 inch lag screws, four 5/16-inch lockwashers, and four 5/16-inch flatwashers.
- (d) Adjust the anchor brackets (Fig. 11) if necessary, and ensure that the booth is level.

#### DOOR REQUIREMENTS (List 1 Booth Only)

**3.05** After anchoring and leveling booth, check door for the following:

- (a) Door remains open 2 to 3 inches when it is at normal position.
- (b) When pushed closed from inside, the door should remain completely closed.

(c) A pull on the handle should open and restore the door to normal position.

(d) See Part 4 for door adjustment.

#### TELEPHONE WIRING

##### First Attachment

**3.06** Attach drop wire hook (Fig. 16) or corner bracket (Fig. 17) (whichever is required) on right rear column adjacent to the entrance hole as follows:

##### A. Drop Wire Hook

(1) Secure drop wire hook (Fig. 16) to clinch nut (provided with booth) using one 1/4-20 by 3/4 FHM screw, one 1/4-inch flatwasher, and one 1/4-inch lockwasher.

##### B. Corner Bracket

- (1) Secure the corner bracket (Fig. 17) to the threaded clinch nut using one 1/4-20 by 3/4 Phillips RHM screw.
- (2) Using the bracket as a template, drill a clearance hole for another 1/4-inch screw.
- (3) Further secure the bracket to the booth using one 1/4-20 by 3/4 Phillips RHM screw, one 1/4-inch flatwasher, one 1/4-inch lockwasher, and one 1/4-inch hex nut.

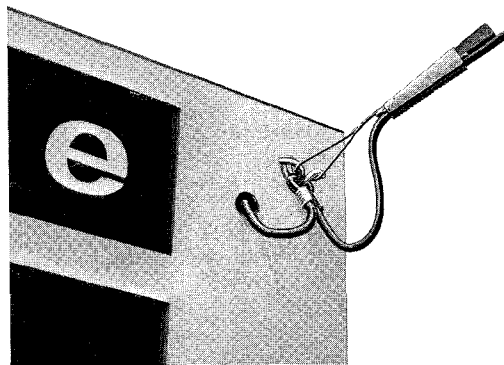

Fig. 16—Drop Wire Hook for First Attachment

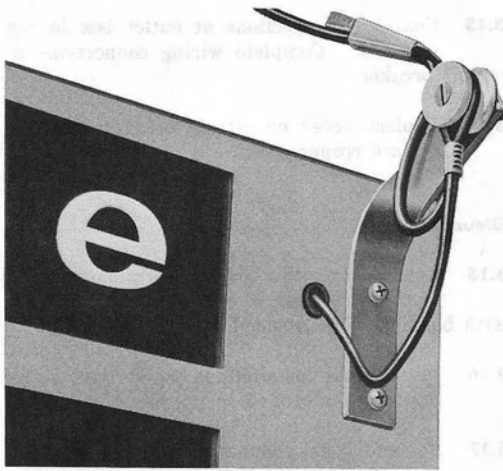

Fig. 17—Corner Bracket for First Attachment

#### Drop Wire

3.07 Telephone wire entrance holes are located in the following locations.

- Top of right-side column
- Bottom of right-side column
- Through metallic conduit to holes provided in the right-rear corner of the booth floor.

3.08 Feed drop wire through entrance hole and terminate on 123A1A station protector (see 3.15).

#### ELECTRICAL SERVICE AND GROUNDING

##### Wiring

3.09 Power wire entrance holes are located in the following locations:

- Top of right-rear column
- Bottom of right-rear column
- Through metallic conduit to holes provided in the right-rear corner of the booth floor.

3.10 Refer to 2.13 for available cords and Fig. 18 and 19 for their usage.

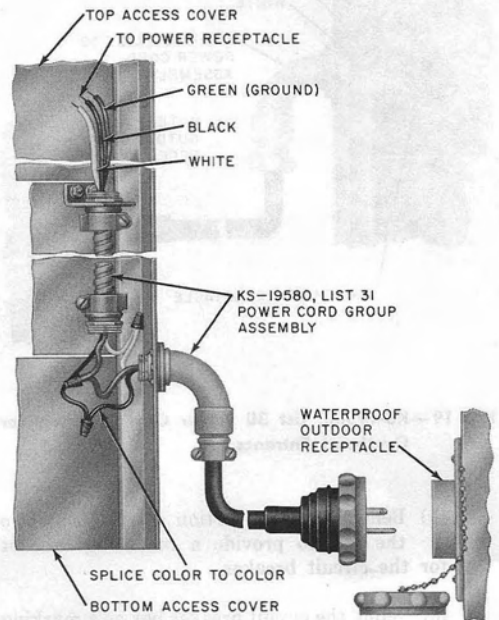

Fig. 18—KS-19580, List 31 Power Cord Group Assembly for Ground Level Entrance

#### ⚡Circuit Breaker

3.11 If a circuit breaker is required, order parts per 2.13 and install as follows:

- (1) Remove corner panel below coin telephone set to make work area accessible (Fig. 20).

**Note:** On current model booths, a mounting bracket is provided to mount the circuit breaker. On early versions, a modification is required as outlined below:

- (a) Using an appropriate saw, cut the channel divider horizontally at a distance of 15-1/2 inches from floor (Fig. 20).

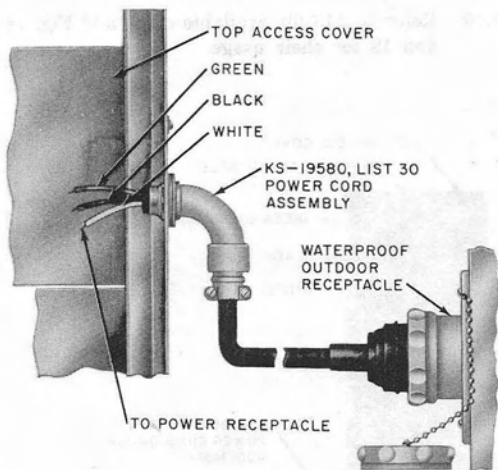

Fig. 19—KS-19580, List 30 Power Cord Assembly for Overhead Entrance

(b) Bend the lower portion of the divider to the left to provide a mounting bracket for the circuit breaker.

(c) Using the circuit breaker box as a marking template, mark the location for the mounting holes. The lower hole should be approximately 5-1/2 inches up from bottom of mounting plate.

(d) Using a 3/16-inch drill bit, drill the two holes.

(2) Install the circuit breaker box using two No. 8-32 by 3/8 Phillips RHM screws and two No. 8-32 hex nuts.

**Note:** The hex nuts are not required on current production models.

(3) Install circuit breaker using hardware furnished.

3.12 Feed BX cable down through left channel and connect BX cable with connector into top of circuit breaker box assembly. Conduit or steel tubing may or may not be connected into bottom of circuit breaker box when underground feed is used.

3.13 Complete connections at outlet box in top of booth. Complete wiring connections to circuit breaker.

3.14 Replace cover on circuit breaker box and replace corner panel.

#### Grounding

3.15 Ensure that the ground terminal of the station protector is connected to the booth with bonding wire provided.

3.16 In multiple installations, bond the booths together for grounding purposes.

3.17 For additional grounding information, refer to Section 508-100-100.

#### OPTIONAL SHELF ARRANGEMENTS AND DIRECTORY RACK (List 1 Booth Only)

3.18 Install the List 21 shelf assembly (Fig. 9) using four 10-32 by 1/2 Phillips FHM screw and four No. 10 CSK washers.

3.19 The KS-19580, List 22 shelf assembly is used along the rear wall in conjunction with a KS-19580, List 25 directory rack assembly.

3.20 Install the List 22 shelf assembly using four 10-32 by 1/2 Phillips FHM screws and four No. 10 CSK washers.

3.21 Install the List 25 directory rack assembly between the two shelves using four 10-32 by 1/2 Phillips FHM screws, two No. 10 flatwashers and two No. 10 lockwashers.

3.22 If a KS-19580, List 26 or 27 nameplate blank is desired, install it along the top edge of List 25 directory rack assembly using the two pins furnished with nameplate.

3.23 Install a KS-19580, List 24 apparatus blank, if required, using two 10-32 by 5/8 Phillips RHM screws, four No. 10 fiber washers, and two No. 10 elastic stop nuts furnished with apparatus blank.

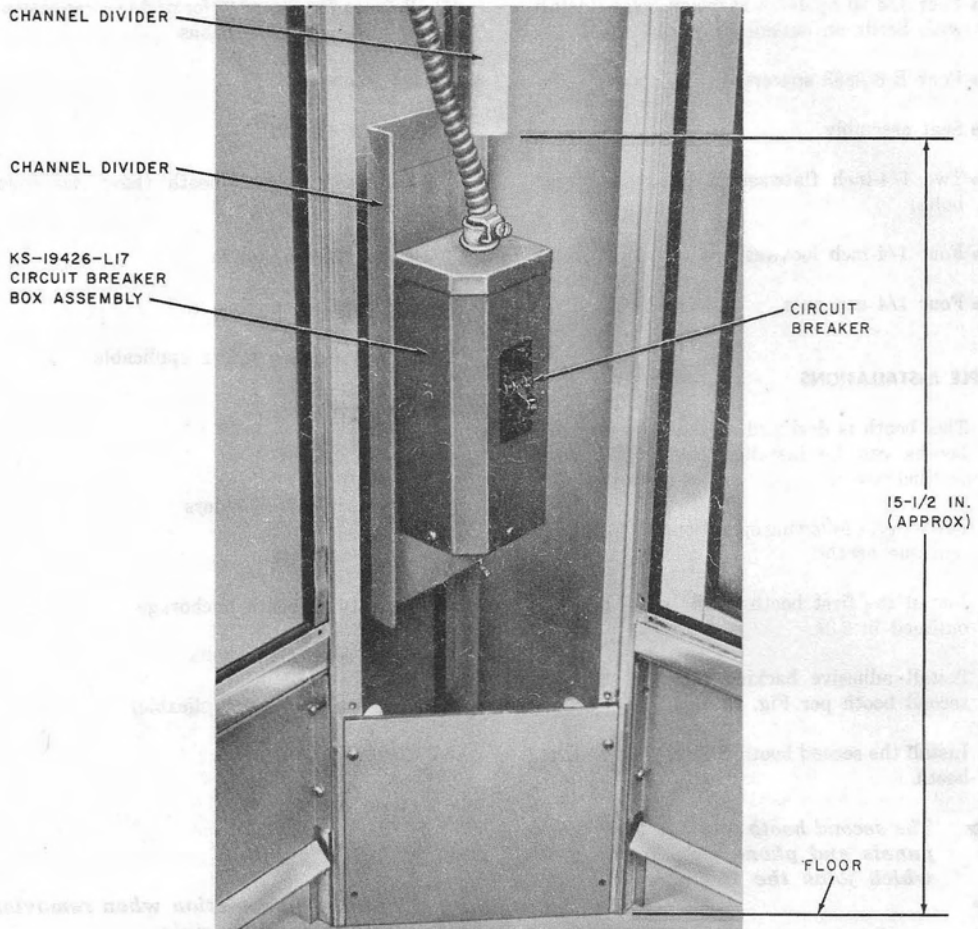

Fig. 20—KS-19426, List 17 Circuit Breaker Box Assembly, Installed

#### SEAT ASSEMBLY (List 1 Booth Only)

3.24 A KS-19425, List 12 mounting plate (Fig. 10) must be used for mounting the seat. Install as follows:

- (a) Install the mounting plate in the same manner as a standard glass panel in the bottom position on the left side of the booth.
- (b) Install a B-650894 clip (furnished with seat assembly) on each corner of the List 12

mounting plate using four 8-32 by 3/8 SEMS RHM screws.



*Install the clips on the inside of the booth. Their purpose is to prevent the removal of retaining strips.*

3.25 Install the seat assembly on the upper portion of the mounting plate using the following items (furnished with seat assembly) and install in the sequence listed.

- Four 1/4-20 by 1-1/8 carriage bolts (install with heads on outside of booth)
- Four B-650893 spacers
- Seat assembly
- Two 1/4-inch flatwashers (front and rear bolts)
- Four 1/4-inch lockwashers
- Four 1/4 cap nuts.

**MULTIPLE INSTALLATIONS**

**3.26** This booth is designed so that two or more booths can be installed side-by-side with only one thickness of panels between booths.

**3.27** Perform the following operations for installing multiple booths.

- (a) Install the first booth in the same manner outlined in 3.04.
- (b) Install adhesive backing weather strip on second booth per Fig. 12 or 13.
- (c) Install the second booth adjacent to the first booth.



*The second booth will not have glass panels and phone sign in the side which joins the first booth.*

- (d) Join two List 1 booths together using a KS-19580, List 20 multiple kit (Fig. 12).
- (e) Join two List 1A booths together using a KS-19580, List 102 multiple kit (Fig. 13).

**Note 1:** The four bolts in the two List 1A booths, that support the leveling brackets, must be removed to allow the two bottom panels to be joined together with the two B-684713-2 bolts.

**Note 2:** A List 1 booth can be joined to a List 1A booth using a List 102 multiple kit provided the List 1 is on the right as viewed from the front.

- (f) Refer to Fig. 21 and 22 for wiring arrangements of multiple installations.

**4. MAINTENANCE**

**BOOTH CHECK POINTS**

- Safe approach to booth (have dangerous conditions corrected)
- Appearance of booth
- Electrical grounding
- Door operation where applicable
- Panels and signs
- Booth lighting
- Directories and binders
- Dome and lights
- Security of booth anchorage
- Loose screws and bolts
- Seat assembly (if applicable)
- Shelf assemblies
- Power cords.

**DOMES ASSEMBLY**



*Use eye protection when removing the dome assembly.*

- 4.01** The B-551952 dome assembly must be removed to make the light assembly accessible. Do this in accordance with Fig. 23.
- 4.02** Replace dome assemblies which do not meet company standards.

**LIGHT FIXTURE AND LIGHT AND BLOWER UNIT**



*Use eye protection when handling fluorescent lamps. Before making any repairs or replacements in electrical equipment, disconnect plug or turn the service switch off and verify that circuit is dead*



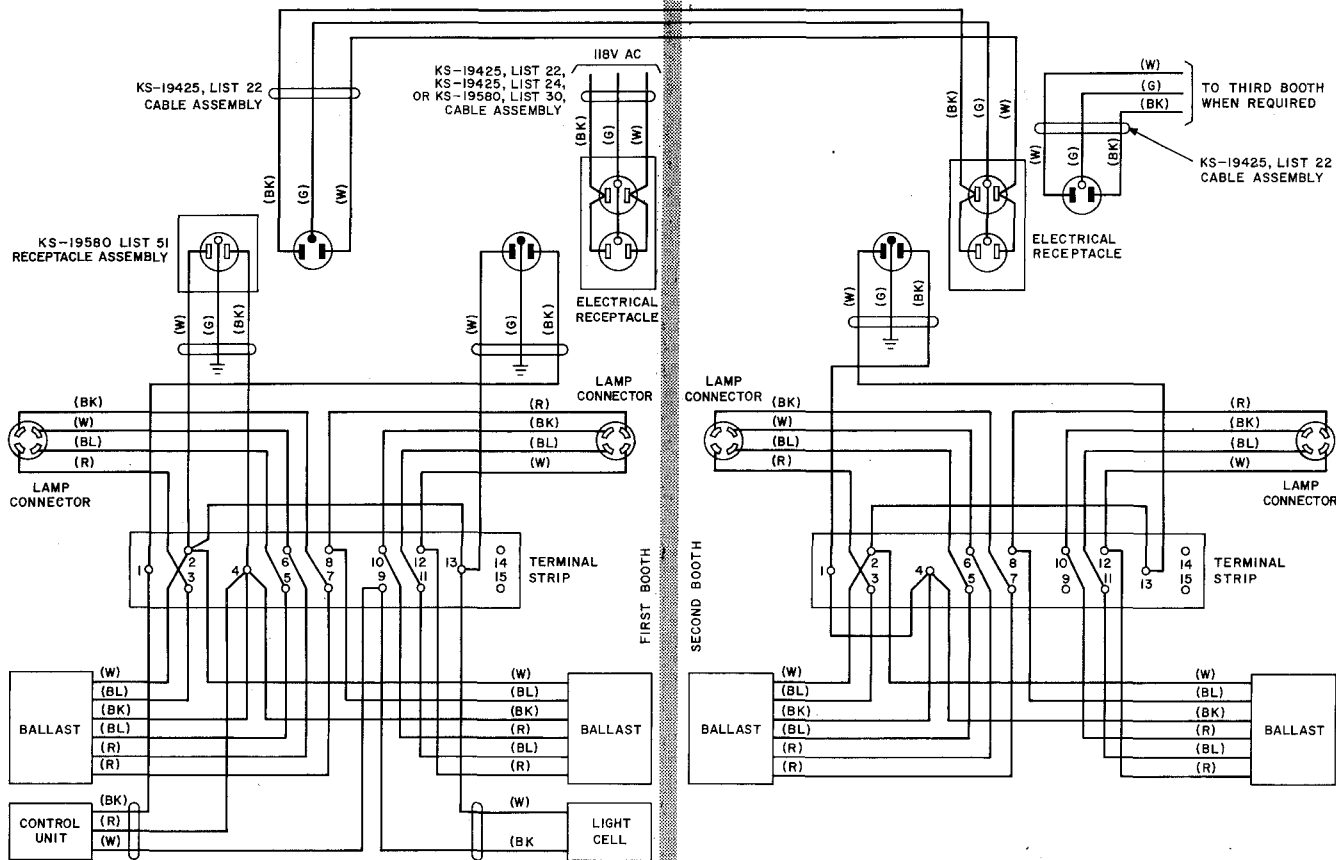

NOTE:

FOR MULTIPLE INSTALLATIONS USING KS-19207, LIST 7 UNITS, AND USING A KS-19261 LIGHT CONTROL UNIT (MAXIMUM OF FIVE BOOTHS FOR EACH CONTROL UNIT), REMOVE THE STRAP WIRE FROM TERMINAL STRIP TERMINALS 1 AND 4 IN FIRST BOOTH. INSTALL A KS-19580, LIST 51 RECEPTACLE ASSEMBLY IN THE FIRST BOOTH. CONNECT ELECTRICAL RECEPTACLE OF SECOND BOOTH TO LIST 51 RECEPTACLE OF FIRST BOOTH USING KS-19425, LIST 22 CABLE ASSEMBLY. CONNECT ELECTRICAL RECEPTACLE OF THIRD, FOURTH, AND FIFTH BOOTHS TO ELECTRICAL RECEPTACLE OF PREVIOUS BOOTH USING KS-19425, LIST 22 CABLE ASSEMBLY.

Fig. 21—Wiring Diagram of Multiple Installation Using KS-19207, List 7 Light Fixture

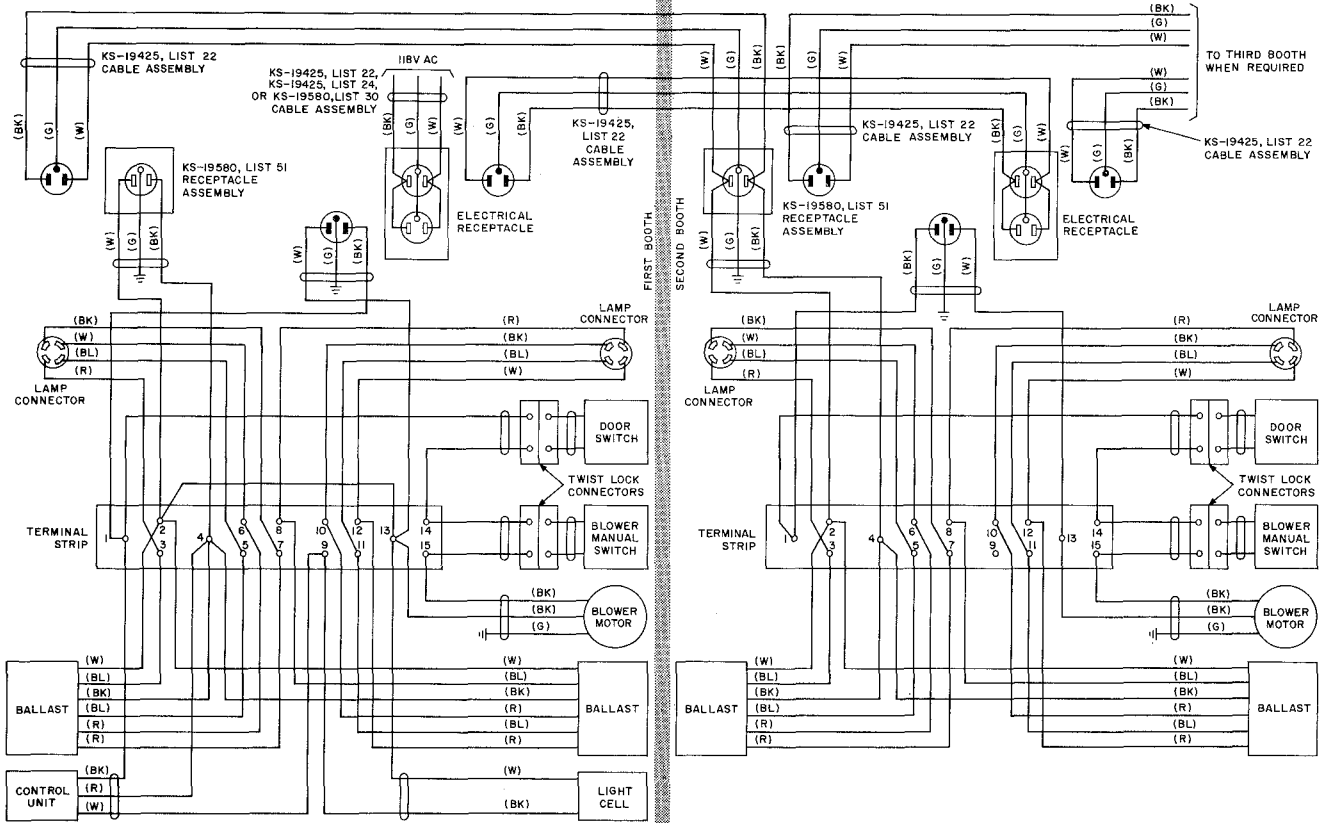

NOTE:  
 FOR MULTIPLE INSTALLATIONS USING KS-19207, LIST 3 LIGHT AND BLOWER UNITS, AND USING A KS-19261 LIGHT CONTROL UNIT (MAXIMUM OF FIVE BOOTHS FOR EACH CONTROL UNIT), REMOVE THE STRAP WIRE FROM TERMINAL STRIP TERMINALS 1 AND 4 IN ALL BOOTHS. REMOVE THE STRAP WIRE FROM TERMINALS 2 AND 13 IN ALL BOOTHS EXCEPT FIRST BOOTH. INSTALL A KS-19580, LIST 51 RECEPTACLE ASSEMBLY IN EACH BOOTH. CONNECT LIST 51 RECEPTACLE OF SECOND, THIRD, FOURTH AND FIFTH BOOTHS TO LIST 51 RECEPTACLE OF PREVIOUS BOOTH USING KS-19425, LIST 22 CABLE ASSEMBLY. CONNECT ELECTRICAL RECEPTACLES IN SAME MANNER.

Fig. 22—Wiring Diagram of Multiple Installation Using KS-19207, List 3 Light and Blower Unit

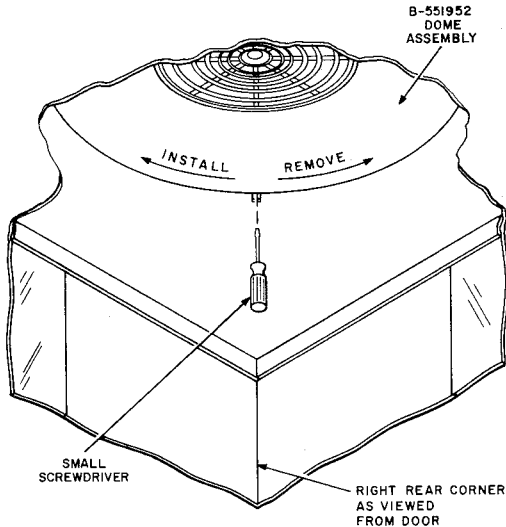

## NOTES:

1. FOR REMOVAL, INSERT SMALL SCREWDRIVER THROUGH SLOT IN CEILING, DEPRESS DETENT SPRING, AND TURN DOME ASSEMBLY COUNTERCLOCKWISE.
2. FOR INSTALLATION, PLACE DOME ASSEMBLY IN CEILING AND TURN IT CLOCKWISE UNTIL DETENT SPRING ENGAGES AND LOCKS DOME.

**Fig. 23—Method of Removing Dome Assembly**

*by checking with an approved voltmeter.*

- 4.03** Each unit is equipped with two fluorescent Circline 40-watt cool white lamps.
- 4.04** On a List 1 booth if the KS-19207, List 3 light and blower unit is present, ensure that the door operated B-650927 switch assembly actuates properly when the door is closed. Also ensure that the manually operated blower switch assembly (B-684779), located in the right front corner of the booth turns the blower on and off.
- 4.05** Ensure that all electrical leads are securely clamped away from the air inlet hole and from the rotating impeller if a blower is present.
- 4.06** When ballast shows signs of leaking compound, replace the complete KS-19207 unit per Section 508-820-100.

## PANEL REPLACEMENT

### Side and Rear Panels

**Warning:** Wear gloves and eye protection when handling glass panels to prevent personal injury. Use care when handling tempered glass. Nicks or scratches will damage the glass and may cause it to shatter. Do not allow metal tools to come in contact with edge of tempered glass. Before installation, examine glass for nicks or chips along edges. If such defects are apparent, do not use this glass.

- 4.07** Replace those panels which are broken or which will not meet local telephone company standards. Refer to Table A for available panels.
- 4.08** Booth panels and signs are held in place by four interlocking retaining strips. They are inserted in sequence as shown in Fig. 24. The No. 4 strip is rippled and is held in place by interface friction.

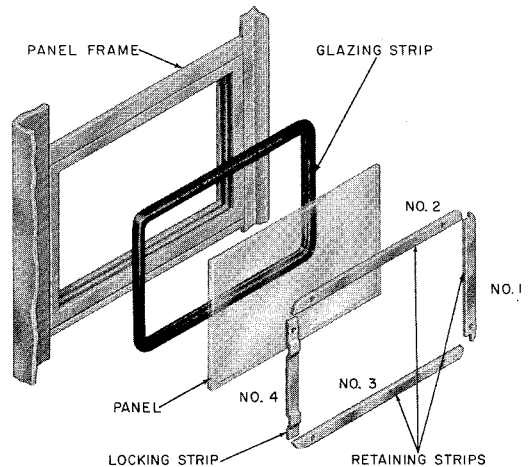

**Fig. 24—Assembly of Side or Rear Panels**

- 4.09** Replace panels as follows:
- (1) Remove No. 4 locking strip.

- (2) Remove retaining strips No. 2 and 3.
- (3) Remove retaining strip No. 1.
- (4) Remove panel and rubber glazing strip.
- (5) Apply rubber glazing strip to replacement panel.
- (6) Insert panel into frame with the beaded edge of glazing strip on the outside.
- (7) Replace retaining strips in sequence as shown in Fig. 24.

**Bottom Panels**

- 4.10** Replace those panels which are broken or which will not meet local telephone company standards. Refer to Table A for available panels.
- 4.11** To remove panels, remove Phillips RH screws (eight for short panel and ten for solid panel).



*The rear bottom panels are equipped with a mounting bracket and leveling device. When ordering replacement panels for the rear, and a mounting bracket angle (B-684710) is not needed, the following numbers may be used.*

- KS-19580, List 49—Solid Panel
- KS-19580, List 50—Short Panel.

**PHONE SIGNS**

- 4.12** The front sign may be removed as follows:
- (a) Remove four self-tapping screws and the top metal retainer which secures the sign.
  - (b) Slide the sign up and out of the enclosure assembly.
  - (c) Use reverse procedure for installing.



*Roof must be removed before side and rear sign panels can be removed. See 4.23 and 4.24.*

**4.13** After roof is removed, the side and rear signs are removed in the same manner as the side panels (see 4.09 and Fig. 24).

**4.14** Replace signs which are broken or which will not meet local company standards. Refer to Table B for available signs.

**DIRECTORIES AND BINDERS**

**4.15** Directory binder rods or hinge fasteners shall not be broken or distorted to the extent that directories are not capable of being held securely in the binder. Hinges shall not be so bent, burred, or distorted as to obstruct the free passage of hinge fasteners or prevent smooth operation of covers.

**4.16** Binder locking devices shall operate freely and lock securely. Adjustable backplates shall be in good condition.

**4.17** Ensure that a rubber bumper is in place on the directory rack hanger to cushion the binder as it drops into the rack.

- B-685401 for KS-19425, List 16 directory rack
- B-697467 for KS-20030, List 3 directory hanger.

**4.18** Install a new bumper, if required as follows:

- (a) Soften old adhesive with trichloroethane and remove.
- (b) Install new bumper using 3M Company EC-1711 adhesive or equivalent.

**PROTECTOR**

**4.19** The booth is equipped with a bonding wire at each of the access covers. Ensure that this wire is secured to the booth and protector.

**4.20** If the bonding wire becomes broken, replace with copper or aluminum wire no smaller than No. 14 gauge.

**4.21** To replace old stationary access cover with new detachable access cover (Fig. 25), perform following operations.

- (a) Remove dome assembly.
- (b) Remove three 8-32 by 5/8 Phillips RH self tapping screws which secure access cover to booth frame.
- (c) Pull access cover forward and disconnect telephone wiring from protector.
- (d) Remove two 8-32 by 3/4 Phillips RHM screws, two No. 8 plain washers, and two No. 8-32 hex nuts which secure protector to access cover.
- (e) Install protector on new access cover per Fig. 25 using hardware retained in (d).
- (f) Install a 10-32 by 1 Phillips RH CRES self tapping screw per Fig. 25. This screw serves as a handle.
- (g) Install two of the three 8-32 by 5/8 Phillips RH self tapping screws in booth framework to accept key holes in new access cover.
- (h) Connect telephone wiring to protector.
- (i) Mount access cover on screws installed in (g).

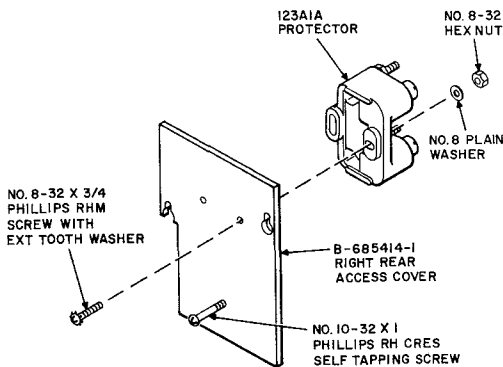

Fig. 25—Assembly of 123A1A Protector on Right Rear Access Cover

## FLOOR

**4.22** If a booth is equipped with an abrasive-clad floor, the finish can be restored with the use of Goodyear Griptred flooring and protective coating, dark gray 592-7005 or equivalent. This can be applied with an ordinary paint brush.

## ROOF

**4.23** If it becomes necessary to remove the roof, remove twelve 8-32 by 5/8 Phillips RH screws and lift off.

**4.24** There are four B-650854 adhesive backed rubber strips along the booth edge under the roof. Check strips for damage each time roof is removed. Replace strips as necessary.

## DOOR REQUIREMENTS (List 1 Booth Only) (See Fig. 26 For Replacement Parts)

**4.25** The door shall operate freely and smoothly without squeaking or chattering. The nylon rollers and door track shall be clean of foreign material and the track shall not be gouged, burred, or scored causing rough operation of the door.

**4.26** With the booth level, when the door is fully closed, it shall remain closed until opened manually, and when in the fully closed position the top of the door shall be in alignment with the door frame.

**4.27** The door shall be held open 2 to 3 inches when in the normal position. Ensure that maximum tension is obtained on spring in center of door (Fig. 26).

**4.28** The door actuated switch shall operate as follows when the manual blower switch is on:

- (a) With the door fully closed, the blower motor shall run.
- (b) With the door held by the door guide spring in the open position specified in 4.27, the blower motor shall be off.



*The door switch shall have no effect on the operation of the booth lamps if the lamps are wired for continuous illumination or automatic light control.*

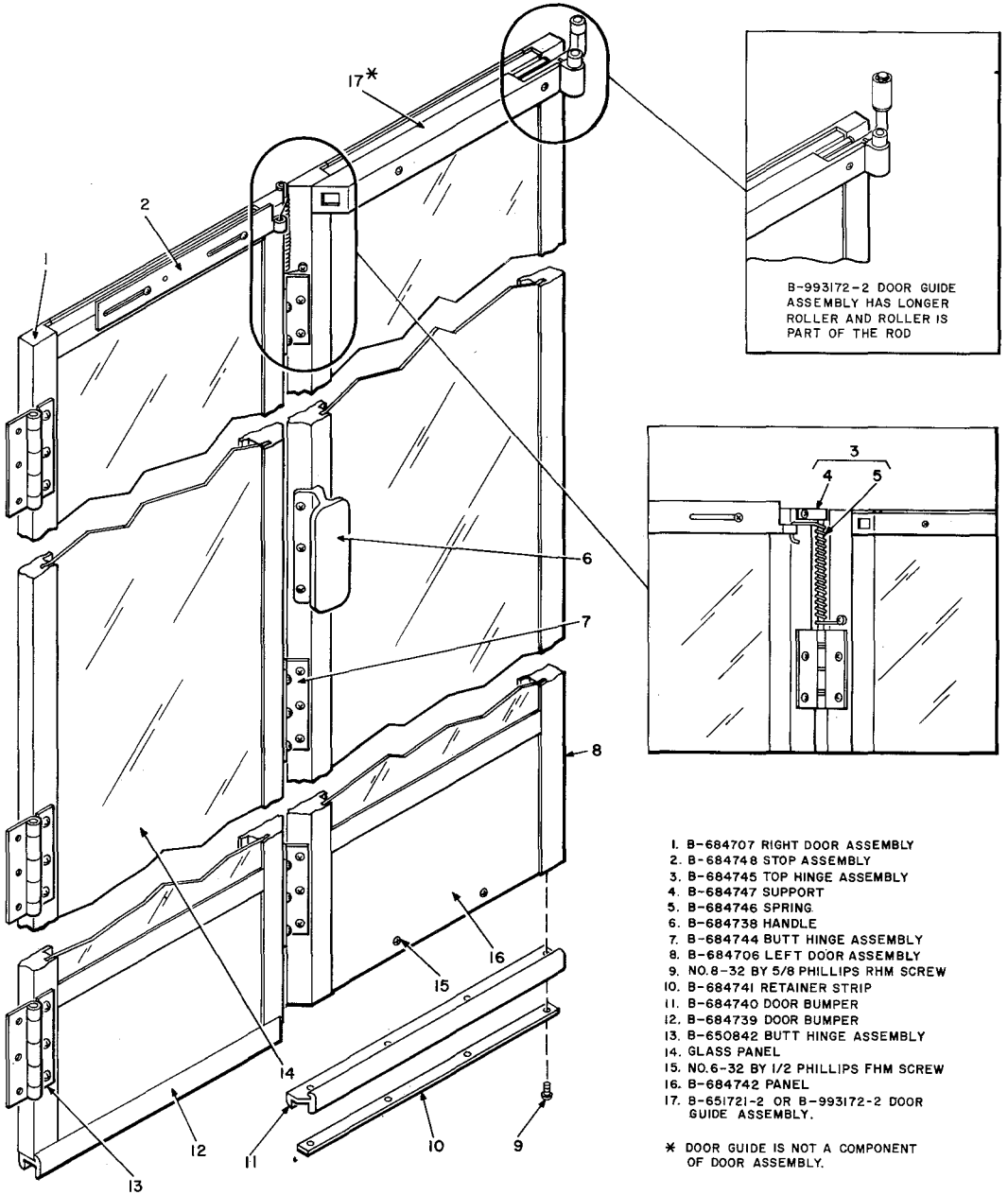

- 1. B-684707 RIGHT DOOR ASSEMBLY
- 2. B-684748 STOP ASSEMBLY
- 3. B-684745 TOP HINGE ASSEMBLY
- 4. B-684747 SUPPORT
- 5. B-684746 SPRING
- 6. B-684738 HANDLE
- 7. B-684744 BUTT HINGE ASSEMBLY
- 8. B-684706 LEFT DOOR ASSEMBLY
- 9. NO. 8-32 BY 5/8 PHILLIPS RHM SCREW
- 10. B-684741 RETAINER STRIP
- 11. B-684740 DOOR BUMPER
- 12. B-684739 DOOR BUMPER
- 13. B-650842 BUTT HINGE ASSEMBLY
- 14. GLASS PANEL
- 15. NO. 6-32 BY 1/2 PHILLIPS FHM SCREW
- 16. B-684742 PANEL
- 17. B-651721-2 OR B-993172-2 DOOR GUIDE ASSEMBLY.

\* DOOR GUIDE IS NOT A COMPONENT OF DOOR ASSEMBLY.

Fig. 26—B-684705 Door Assembly

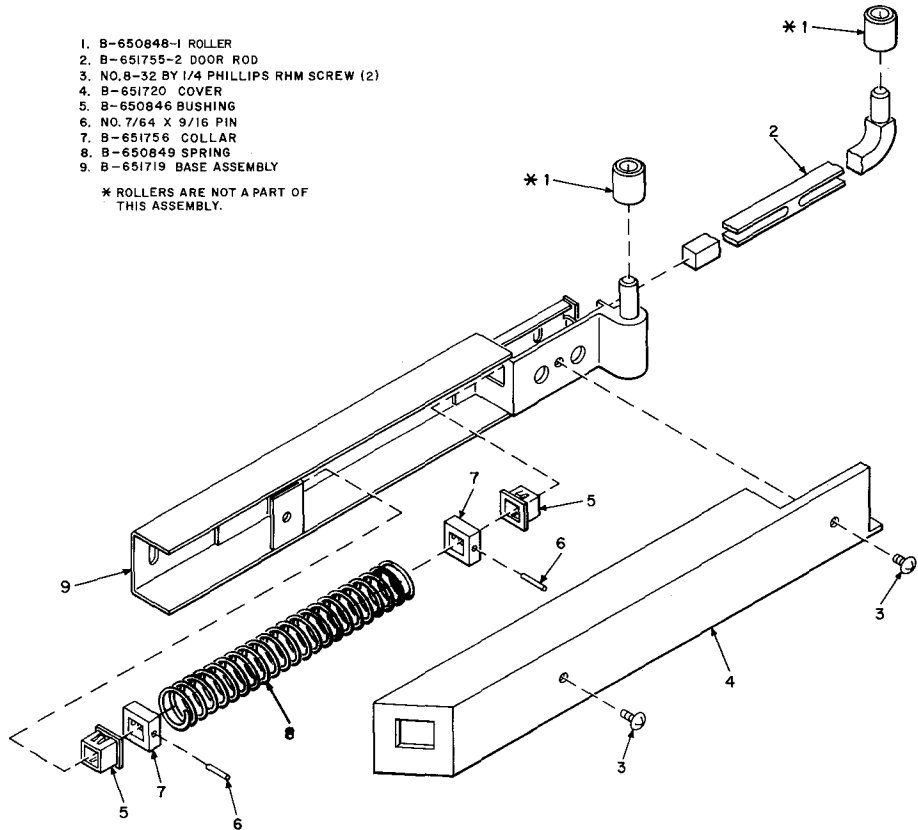

Fig. 27—B-651721-2 Door Guide Assembly

- 4.29 The clear door opening shall be a minimum of 21 inches.
- 4.30 Rubber bumpers at the bottom of the doors shall not be frayed or torn to expose underlying metal. Screws and retainer strips shall hold bumpers securely.
- 4.31 Ensure that angle bracket associated with felt bumper in door track is tight.

**DOOR GUIDE ASSEMBLY (List 1 Booth Only)**

- 4.32 The KS-19580 booth will have either a B-651721-2 short-roller door guide assembly (Fig. 27) or a B-993172-2 long-roller door guide assembly (Fig. 28).
- 4.33 The B-993172-2 door guide assembly requires a different ceiling, baffle, and a deeper track to accommodate the longer roller. If a problem exists with door guide rollers jumping out of the track, and this cannot be corrected by

1. B-650848-1 ROLLER
2. B-993177 DOOR ROD ASSEMBLY
3. NO. 8-32 BY 1/4 PHILLIPS RHM SCREW (2)
4. B-651720 COVER
5. B-650846 BUSHING
6. NO. 7/64 X 9/16 PIN
7. B-651756 COLLAR
8. B-650849 SPRING
9. B-651719 BASE ASSEMBLY
10. L-764807 ROLLER

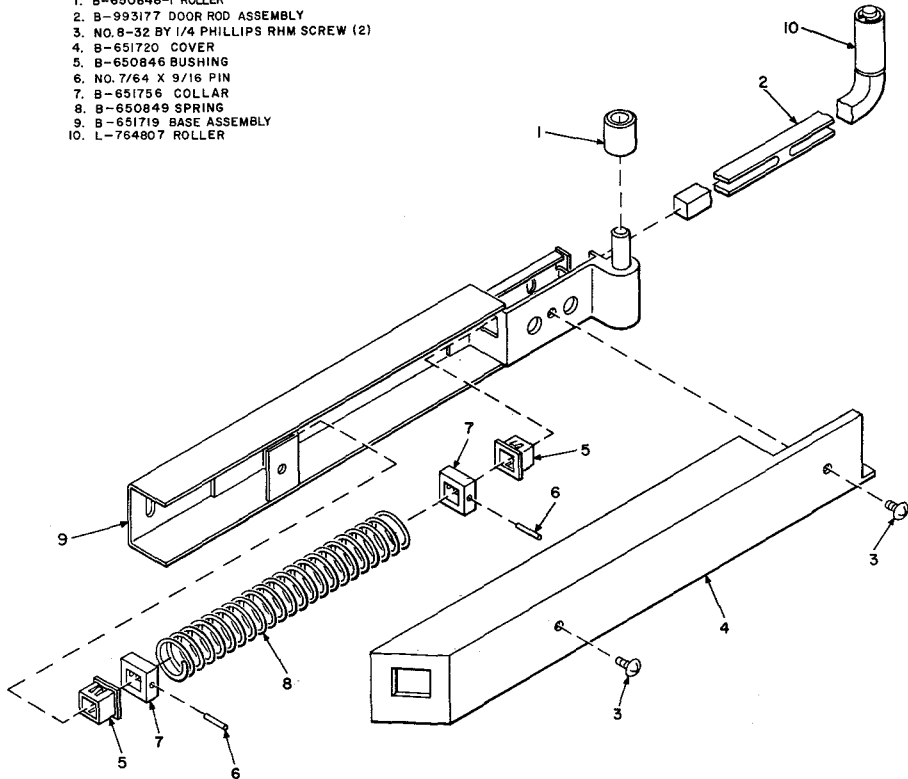

Fig. 28—B-993172-2 Door Guide Assembly

adjustment as directed in paragraph 4.37, booths can be modified to accept the long-roller door guide. Parts and instructions are included in PPE-423 Track and Door Guide Modification Kit.



***This modification is extensive and should be investigated before field application.***

- 4.34 If door hinges squeak, lubricate them at each joint between the barrels with KS-14774, L2G lubricating grease or equivalent; a KS-14796 oiler may be used.
- 4.35 Replace glass panels in similar manner as side panels (Fig. 24).
- 4.36 Replace damaged bumpers along bottom of door (Fig. 26).
- 4.37 To change door closing spring tension, adjust B-684748 stop assembly as follows:
  - (a) Loosen the two stop assembly mounting screws.
  - (b) Move the assembly left or right to obtain the spring tension required.



(c) Tighten screws and recheck tension.

**4.38** When door rollers do not have proper vertical engagement in the track, adjust B-651721-2 or B-993172-2 door guide assembly as follows:

- (a) Remove two screws and B-651720 cover (Fig. 27 and 28).
- (b) Loosen the three door guide assembly mounting screws (No. 8 by 1/2 Phillips RH self-tapping).
- (c) Move the door guide assembly up or down to obtain proper roller position.

**Note:** In most cases, the maximum upward position will be required.

- (d) Tighten screws and recheck rollers.
- (e) Install B-651720 cover.

#### REPLACEMENT PARTS

**4.39** The parts listed in Table C are not shown in Fig. 26, 27, or 28 but may be ordered as necessary. Refer to Tables A and B for panels and signs.



*The B-651921 bumper (Fig. 29), listed in Table C, is a replacement part; however, all booths have not been equipped with these bumpers. A No. 10-32 tapped hole is provided on the right side rail for installation. Ensure that this bumper, if required, is either present or installed on each maintenance check. Use screw described in Fig. 29.*

#### CLEANING

**4.40** Clean booth as directed in Section 508-100-101.

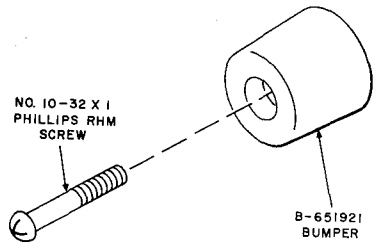

**Fig. 29—B-651921 Bumper With Mounting Screw**

◆ TABLE C ◆

## REPLACEMENT PARTS

NAME	PART NO. LIST NO., OR DESCRIPTION	REMARKS
Actuator Assembly	B-650929	Actuates B-650927 switch assembly
Angle	B-684710	Adjustable mounting bracket in rear and right front corner (Right front corner for List 1 booth only)
	B-994924	Adjustable mounting bracket in right front corner of List 1A booth
	B-684711	Adjustable mounting bracket in left front corner
	B-650824	Support for B-650825 bumper
	L-764805	Support for L-764806 bumper
Bracket	B-994165	Holds dome in ceiling assembly
Bumper, Felt	B-650825	Located in right end of a shallow door track as viewed from outside front of booth
	L-764806	Located in right end of a deep door track as viewed from outside front of booth
Bumper, Aluminum	B-650826	Located in left end of a shallow door track as viewed from outside front of booth
Bumper, Rubber	B-684714	Used in left door frame
	B-651921	Used on right rail as door stop
Cover Assembly	B-685414-1	123A1A protector access cover
Dome Assembly	B-551952	Circular lens and ventilator under light fixture
Enclosure Assembly	B-685376	Encloses front sign
Floor	B-684719-1	Tread plate
Grommet	B-684716	Used at telephone wire entrance holes
Header Assembly	B-684727	
Lamp	40 Watt-Circline cool white	Used in KS-19207 light unit

## ◆ TABLE C (Cont) ◆

## REPLACEMENT PARTS

NAME	PART NO. LIST NO., OR DESCRIPTION	REMARKS
Nut	B-684712	Used in conjunction with mounting bracket angles
Plug	Fastex No. 207-560401- 00-3102	Plug button for plugging power wire entrance holes
	Fastex No. 207-440401- 00-0667	Plug button for plugging light-control entrance hole
Retainer	B-562371	Use with B-562370 locking spring
Roof Assembly	B-651303	
Spring	B-562370	Locks dome in place
Strip, Glazing	B-685410-1	Side or rear sign
	B-685410-2	Side and rear glass panels (large)
	B-685410-3	Side and rear glass panels (small)
	B-685410-4	Door panels
	B-685411-1	Multiple installation sign panel assembly
	B-685411-2	Aluminum or porcelain type panels (large)
	B-685411-3	Aluminum or porcelain type panels (small)
	B-685410-5	Front sign
Strip, Retaining	B-685372-1	Top of door panels
	B-685372-2	Either side of door panels
	B-685372-3	Bottom of door panels
	B-685372-4	Either side of large side panels
	B-685372-5	Locking strip for large side panels
	B-685372-6	Either side of small side panels
	B-685372-7	Top of small side panels, large side panels, or side and rear phone signs

◆ TABLE C (Cont) ◆

REPLACEMENT PARTS

NAME	PART NO. LIST NO., OR DESCRIPTION	REMARKS
Strip, Retaining (Cont)	B-685372-8	Locking strip for small side panels
	B-685372-9	Bottom of small side panels, large side panels, or side and rear phone signs
	B-685372-10	Either side of phone signs (front and rear)
	B-685372-11	Locking strip for phone signs
Strip, Rubber	3M Company Pressure sensitive tape No. 4508, 1/8-inch thick, 3/4-inch wide, black vinyl foam	Adhesive backed roof gaskets*
Switch Assembly	B-650927	Energizes light and blower when door is closed
	B-684779	Turns blower motor on and off

\*Roof gaskets should be checked for damage each time roof is removed.