

## BLOCK AND BUILDING CABLE PLACING

CONTENTS	PAGE
1. GENERAL . . . . .	1
<b>PRECAUTIONS</b> . . . . .	1
<b>LOCATING CABLE RUNS</b> . . . . .	2
<b>SEPARATIONS</b> . . . . .	3
2. <b>POLE-TO-BUILDING ATTACHMENTS</b> . . . . .	3
3. <b>INTERMEDIATE AND DEAD-END ATTACHMENTS ON OUTSIDE WALLS</b> . . . . .	3
<b>STRAND SUPPORTED CABLE</b> . . . . .	8
<b>CABLE CLAMPED DIRECTLY TO WALLS</b> . . . . .	11
<b>BUILDING-TO-BUILDING SPANS</b> . . . . .	13
4. <b>INTERMEDIATE AND DEAD-END ATTACHMENTS ON INSIDE WALL</b> . . . . .	15
<b>STRAND SUPPORTED CABLE</b> . . . . .	17
<b>CABLE CLAMPED DIRECTLY TO WALLS AND CEILINGS</b> . . . . .	23
<b>ATTACHMENTS TO STRUCTURAL STEEL FRAMEWORK</b> . . . . .	25
<b>DEAD ENDING</b> . . . . .	25
<b>INTERMEDIATE SUPPORTS</b> . . . . .	26

### 1. GENERAL

1.01 This section covers the methods of placing and supporting cable on the surfaces and framework of buildings.

1.02 This section is reissued to include new methods and materials used in block and building cable construction and to incorporate into one practice Sections 627-375-200, 627-610-211, 627-610-215, 627-610-220, 627-610-221, 627-630-200, and 627-630-201 which are now canceled. Since this is a general revision, arrows ordinarily used to indicate changes have been omitted.

1.03 For specific description on types of hardware and anchoring devices and their application to the various types of building surfaces, refer to Section 627-610-200.



*Throughout this practice several different types of dead-ending hardware, ie, strand grip, Strandvise, and guy clamps are shown in the illustrations. Any of these methods may be used. To determine which is most suitable consider the compatibility of the strand size and availability of materials.*

### PRECAUTIONS

1.04 Take all necessary precautions to avoid injury from electric light and power circuits, moving machinery, belts, elevators, counter weights, steam pipes, etc.

1.05 Work on 2.2M strand should always be performed from a ladder as this size of strand is not intended to support the weight of a platform or cable car. When using a ladder on pole-to-building spans, the ladder should always be placed so that it pushes the strand and building attachment toward the building; otherwise, it may cause the building attachment to pull out of the wall.

**Caution:** *In no case shall platform or cable cars be suspended from strand of any size that is attached to a building.*

1.06 When lashing cable in pole-to-building spans, avoid any excessive down pull on the line used to pull the lasher.

1.07 Where self-supporting cable is used in a pole-to-building span, it may be considered as unexposed in this section. The requirements for use of fuse cable as described in Section 638-205-015 should be followed. **The support strand must be bonded to the main suspension strand at the pole.** The strand should not be brought into the building unless special conditions make it necessary. Should the strand be brought into the building, it must be bonded and grounded or insulated in the same manner as the cable shield. If the strand is dead ended on the outside of the building, it need not be grounded at the building end.

1.08 Use care in handling cable to prevent sheath damage, ie, kinks, cuts, and abrasion.

1.09 When pulling cable through conduit, use cable lubricant and pull with a slow steady pull.

1.10 When it is necessary to enter private property, notify the owner or his representative before beginning work. Avoid damage to lawns and shrubs. After completing work, leave property in a clean and orderly condition.

1.11 Arrangements for the use of electric power necessary for the work shall be made by the supervisor with the property owner, building electrician, or other authorized persons.

#### LOCATING CABLE RUNS

1.12 The plant engineer's detailed plans should indicate the proposed locations of all cable, splices, and terminals. They should also include precautions for protecting exposed cables and the type of construction to be used, ie, cable on strand or cable attached directly to walls. Special right-of-way requirements such as **keep off**, property owner inspection, etc, should be indicated.

1.13 Before starting work, a preliminary survey should be made of the proposed cable run to determine if any conflicts exist. If a revision of the plans or additional rights-of-way are found to be needed, consult the supervisor. The property owner or his representative should be contacted

and advised as to the manner in which the work is to be done.

1.14 In the selection of a suitable location on building walls for placing cable, the following items should be considered:

- Locate runs that will afford work to be performed safely.
- Locate runs where appearance is least objectionable.
- Locate runs to minimize the amount of cable required, avoiding diagonal runs.
- Choose the path that will require a minimum number of bends.
- Locate cable where it will not be exposed to mechanical damage.
- Do not attach cable to walls that appear to be temporary; masonry walls rather than wood are preferred.
- Do not locate vertical runs less than 24 inches from projecting corners and whenever practical in the inside angle formed by intersecting walls.
- On blank walls locate cables a minimum of 8 feet from ground. In alleyways where truck traffic occurs a higher attachment should be obtained.
- Avoid down spouts, pipes, fire escapes, ladder counterweights, etc.
- On masonry walls attachments to smooth surfaces rather than rough stone or concrete are preferable.
- In basements, avoid coal bins, ash pits, coal freight chutes, and grating. Avoid boilers, fire boxes, uncovered steam pipes, and gasoline engines.
- When it is necessary to place cable exposed to view within the finished portions of buildings where appearance is a factor, locate cable at ceiling or baseboard level. Locate vertical runs in corners to take advantage of moldings, beams, columns, etc, as aids in concealment.

**1.15** When selecting splice location, consider the following recommendations:

- Do not locate splices over doorways.
- Use vertical splices only when horizontal splices cannot be made.
- Avoid locations where appearance of a splice would be objectionable.
- Locate splice so that terminal stubs or branch cables will parallel the main cable for at least 6 inches before entering the splice.

**1.16** Locate terminals in accordance with the plant engineer's detail plans. If the specified location appears unsatisfactory from an installation viewpoint or creates potential right-of-way or maintenance difficulties, notify the supervisor.

**1.17** When conduit, raceway, or under floor duct systems have been provided for cable, the engineer shall furnish with the detail plans a schematic drawing indicating the system layout. The schematic will designate specific conduits, raceways or ducts which are to contain specific cables.

**1.18** Do not place cables in locations where it will overhang swimming pools.

#### **SEPARATIONS**

**1.19** In general, separations are required for electrical reasons. However, uncovered steam and hot water pipes, stationary metal gratings, etc, also must be considered because of excessive heat and abrasions.

**1.20** Table A and B specify the minimum separations that are required on or inside buildings between telephone cable plant and foreign conductors or metallic objects.

## **2. POLE-TO-BUILDING ATTACHMENTS**

**2.01** Generally, the maximum span from the pole to the building should be restricted to 100 feet.

**2.02** The minimum bending radius for block and house cable is computed by multiplying the cable diameter by 6. For example, a cable with a one-inch diameter would have a minimum bending radius of 6 inches.

**2.03** The dead-end pole in pole-to-building spans should be guyed in accordance with the standard guying procedures covered in the 621 Division of the Bell System Practices.

**2.04** Some pole-to-building spans will cause pull on the dead-end pole. If this pull is 3 feet or more, the pole should be side guyed accordingly. Where it is not possible to guy the pole for this unbalanced condition, the pole should be treated as a slack span pole as described in Section 627-240-225.

**2.05** Place cable in pole-to-building spans at the stringing tensions shown in Table C.

**2.06** Typical methods of pole-to-building attachments are shown in Fig. 1 and 2. Fig. 1 shows the typical methods for attaching to the face of a wall. Fig. 2 shows the typical methods for attaching to the side wall of a building.

## **3. INTERMEDIATE AND DEAD-END ATTACHMENTS ON OUTSIDE WALLS**

**3.01** The use of suspension strand is preferred to cable clamps when supporting longer runs of cable on outside walls. Fewer holes are required to be drilled and clearing obstructions such as drain pipes, wall projections, etc, is simplified with the use of suspension strand and wall brackets.

TABLE A

SEPARATION AND PHYSICAL PROTECTION FOR CABLE LOCATED BETWEEN BUILDING ATTACHMENT AND TELEPHONE PROTECTOR<sup>1</sup>

	TYPE OF PLANT INVOLVED	MINIMUM SEPARATIONS
Electric Supply	Bare light or power wire of any voltage	5 feet See Note 2
	Service drops or open wiring not over 750 volts	4 inches
	Wires in conduit, or in armored or nonmetallic sheath cable, or power ground wires	2 inches
Radio And Television	Antenna lead-in and ground wires	4 inches
Signal Wire	Open wiring or wires in conduit or cable	2 inches
Communication Wires	Foreign open wiring and wires in conduit or cable	2 inches
	Between exposed and nonexposed telephone company wires	
	Community television systems coaxial cables with shields at ground potential	None
Metallic Objects	Downspouts and gutters	2 inches
	Stationary gratings, etc.	See Note 3
Telephone Ground Wire		None
Sign	Neon signs and associated wiring from transformer	6 inches See Note 4
Lightning System	Lightning rods and wires	6 Feet See Note 5
Telephone Ground Rods to Other Ground Rods		6 Feet

**Note 1:** This table applies only to cable attached to buildings and feeding a fuseless or fused protector. Separations apply to crossings and to parallel runs. Minimum separations between cable outside or inside buildings, and the type of plant involved are as shown.

**Note 2:** Power is to be turned off when working above bare wire. Ladders should be placed so as to maintain a 5-foot minimum clearance.

**Note 3:** Use B Cable Guard or 2 layers of vinyl tape extending at least 2 inches beyond each side of object being crossed.

**Note 4:** Avoid neon sign location if alternate run is possible.

**Note 5:** Separations of less than 6 feet between drop, block, and station wiring, or telephone ground wires and lightning wires or rods are permissible under the following conditions:

- (a) Where telephone, power, and lightning rod ground connections are made to a common grounding medium as specified in Section 460-100-201.
- (b) Where separate driven ground rods are used for telephone, power, and lightning rod installations, and the ground rods are bonded together as specified in Section 460-100-201.

**Caution:** In no case shall the separation be less than 4 inches.

TABLE B

**SEPARATION AND PHYSICAL PROTECTION FOR CABLE LOCATED  
BETWEEN PROTECTOR AND TELEPHONE EQUIPMENT OR STATION<sup>1</sup>**

	TYPE OF PLANT INVOLVED	MINIMUM SEPARATIONS
Electric Supply	Bare light or power wire of any voltage	5 feet See Note 2
	Open wiring not over 300 Volts	2 inches See Note 3
	Wires in conduit, or in armored or nonmetallic sheath cable, or power ground wires	None
Radio And Television	Antenna lead-in and ground wires	4 inches See Note 3
Signal Or Control Wires	Open wiring or wires in conduit or cable	None
Communication Wires	Community television systems coaxial cables with shields at ground potential	None
Telephone Drop Or Block Wire	Using fused protectors	2 inches See Note 3
	Using fuseless protector or where no protector required	None
Telephone Ground Wire		None
Sign	Neon signs and associated wiring from transformer	6 inches See Note 4
Lightning System	Lightning rods and wires	6 feet See Note 5
Pipe	Steam or hot water or heating ducts	See Note 6
Stationary Grating, Metal Shutter Grillwork, Etc.		See Note 3

**Note 1:** This table applies only to cable from fuseless or fused protector to telephone equipment and telephone wiring requiring no protector. Separations apply to crossings and to parallel runs. Minimum separations between cable, outside or inside buildings, and type of plant involved are as shown.

**Note 2:** Power is to be turned off when working above bare wire. Ladders shall be placed to maintain a 5-foot minimum clearance.

**Note 3:** Use B Cable Guard or 2 layers of vinyl tape extending at least 2 inches beyond each side of object being crossed.

**Note 4:** Avoid neon sign location if alternate run is possible.

**Note 5:** Separations of less than 6 feet between drop, block, and station wiring, or telephone ground wires and lightning wires or rods are permissible under the following conditions:

- (a) Where telephone, power and lightning rod ground connections are made to a common grounding medium as specified in Section 460-100-201.
- (b) Where separate driven ground rods are used for telephone, power, and lightning rod installations, and the ground rods are bonded together as specified in Section 460-100-201.

**Note:** In no case shall the separation be less than 4 inches.

**Note 6:** Excessive heat may damage plastic insulation; therefore, avoid heating ducts and other heat sources.

**TABLE C**  
**STRINGING TENSIONS FOR STRAND**  
**IN POLE-TO-BUILDING SPANS**

SIZE OF STRAND	APPROXIMATE STRINGING TENSION (POUNDS)
2.2M	300
6M	600
6.6M <sup>1</sup>	600

*Note 1:* 6.6M is suspension strand for self-supporting cable

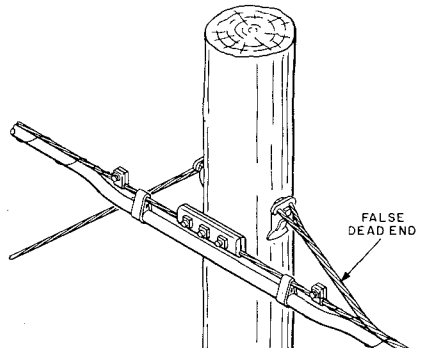
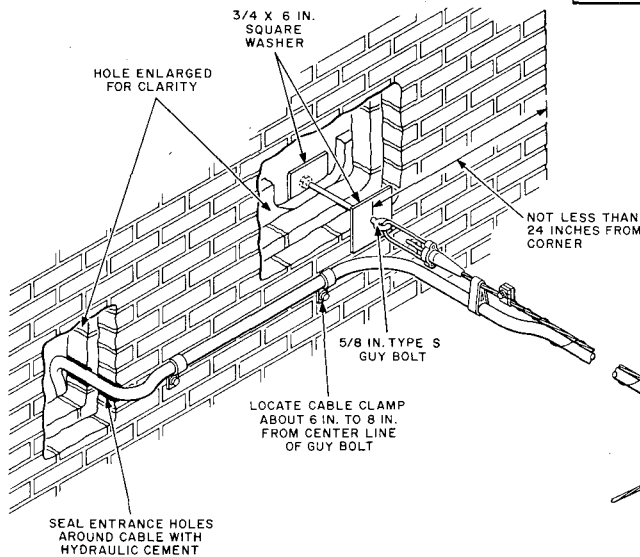
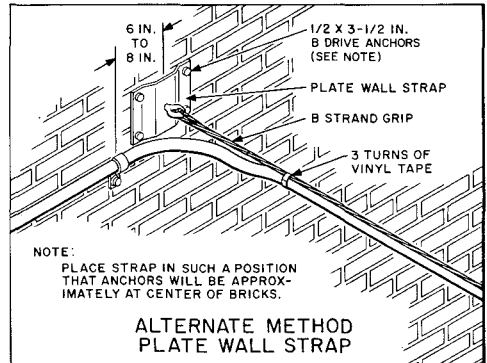
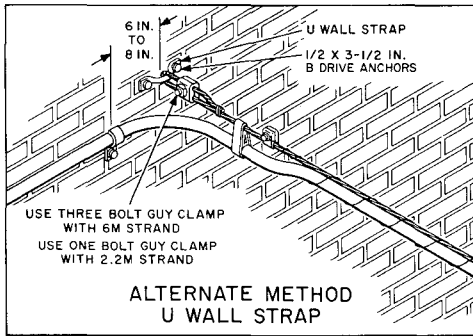

**PREFERRED METHOD**

**Fig. 1—Pole-To-Building Attachments To Face of Wall**

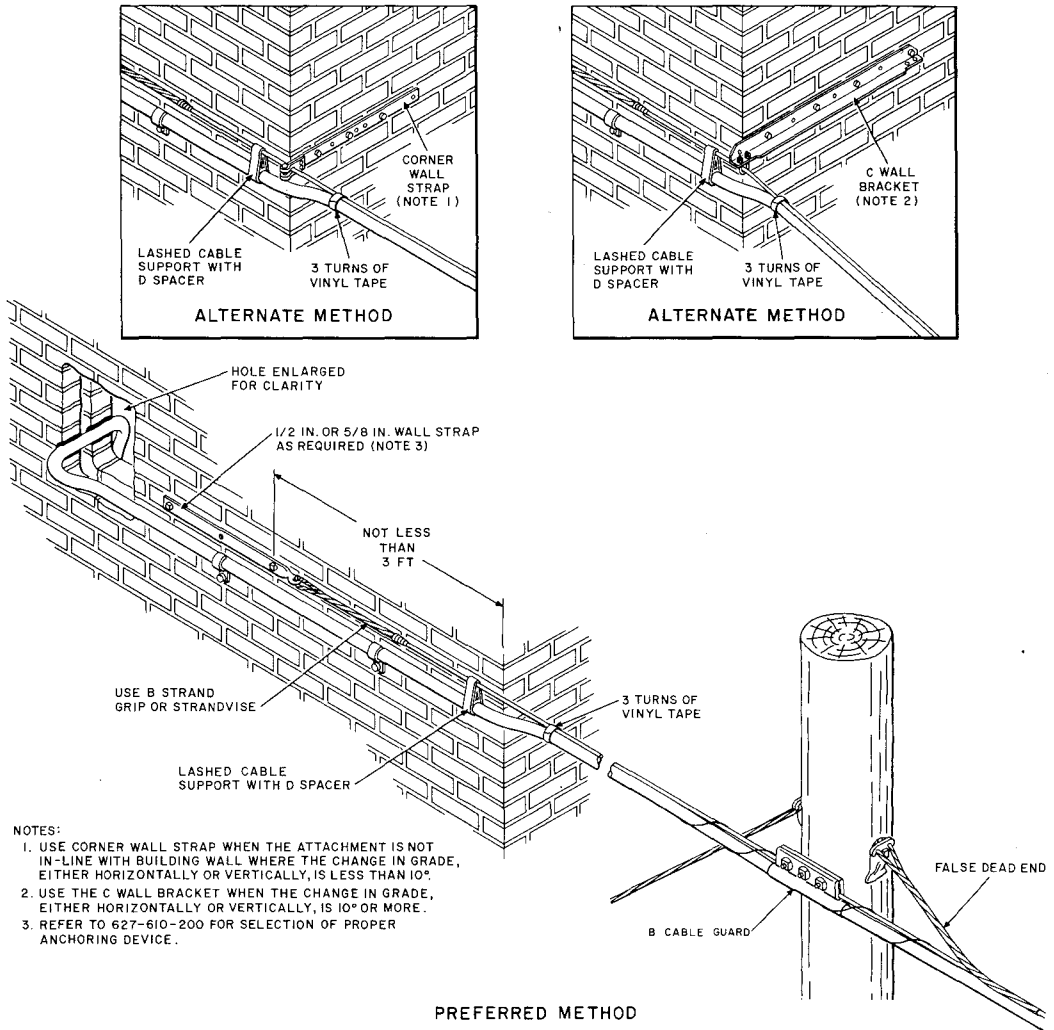

Fig. 2—Pole-To-Building Attachments to Side of Wall

**3.02** In extreme cases where it is impractical to lash a cable, cable rings may be substituted. Use 1-1/2 inch No. 22 Cable Rings with 2.2M strand and 1-1/2 inch No. 6 Cable Rings with 6M strand. The maximum diameter cable that these rings will accommodate is 1-3/16 inches.

**3.03** The stringing tensions or equivalent sag specified in Table D should be used for

strand placed on building walls. However, due to the considerable variation in strength of building structures the table should be used only as a guide. To obtain spans long enough to obtain the sags shown in Table C, it may be necessary to temporarily drop the strand from one or more intermediate supports during the tensioning operation.

STRAND SUPPORTED CABLE

3.04 A typical installation for dead-end and intermediate attachments for strand supported cable is shown in Fig. 3. Brackets should be spaced about 40 feet apart. Use the D Wall Bracket except where additional clearance is required to clear obstructions, in which case an E Wall Bracket is used.

TABLE D  
TENSIONING STRAND FOR CABLE ALONG BUILDING WALLS

SPAN IN FEET	2.2M STRAND		6M STRAND		6.6M STRAND	
	SAG (IN)	TENSION (LB)	SAG (IN)	TENSION (LB)	SAG (IN)	TENSION (LB)
40	1	185	2	266	4	520
80	2	375	4	540	12	695
100	3	390	6	560	17	760
120	4	420	8	610	23	855
140	6	385	11	600	30	875

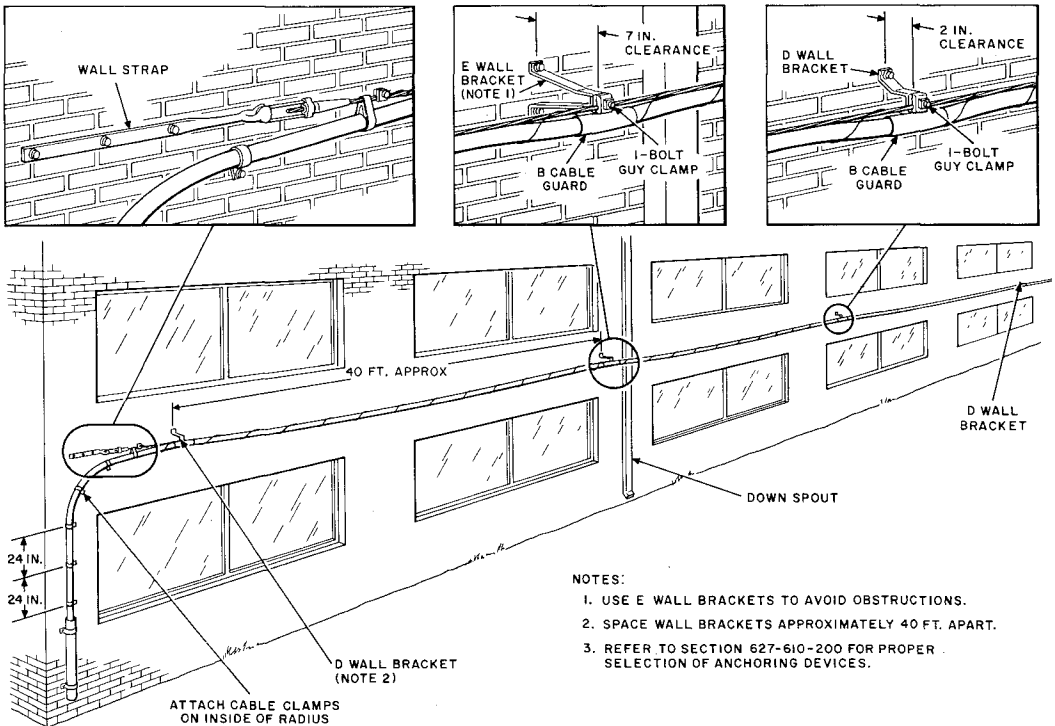

- NOTES:
1. USE E WALL BRACKETS TO AVOID OBSTRUCTIONS.
  2. SPACE WALL BRACKETS APPROXIMATELY 40 FT. APART.
  3. REFER TO SECTION 627-610-200 FOR PROPER SELECTION OF ANCHORING DEVICES.

Fig. 3—Intermediate and Dead-End Attachments to Outside Walls



**3.05** When attaching strand to outside corners of masonry or brick surfaces, use a B Wall Bracket as shown in Fig. 4. When attaching at inside corners, use U Wall Straps as shown in Fig. 5.

**3.06** When attaching to inside or outside corners of frame buildings the strand should be dead ended in both directions using wall straps as shown in Fig. 6.

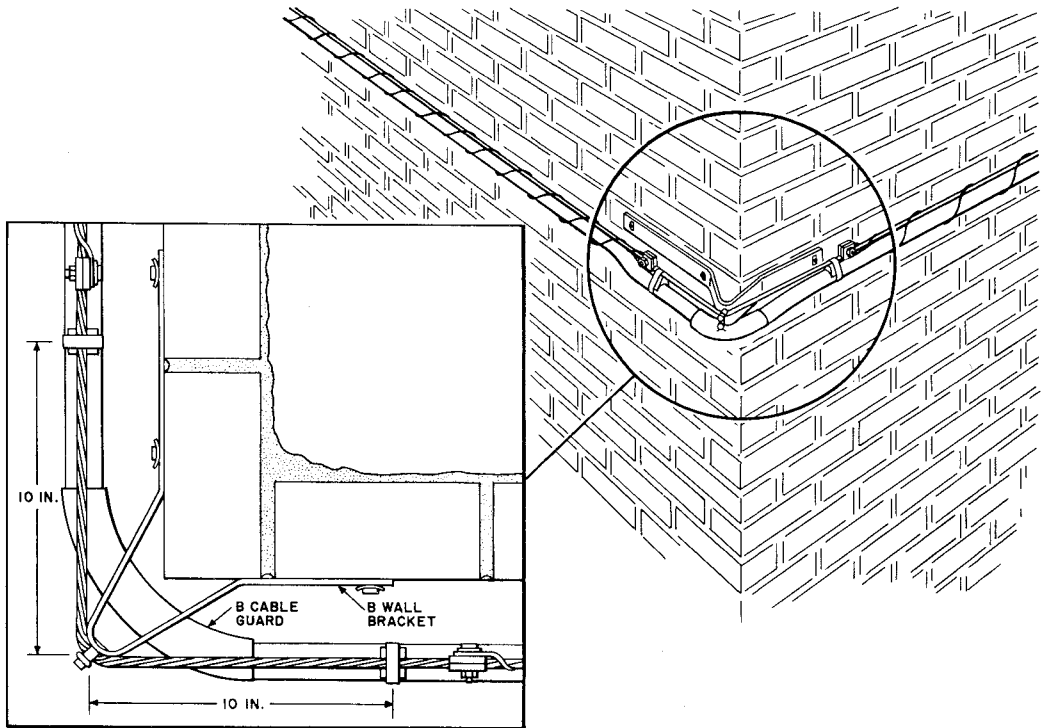

**Fig. 4—Outside Corners (Masonry Surfaces)**

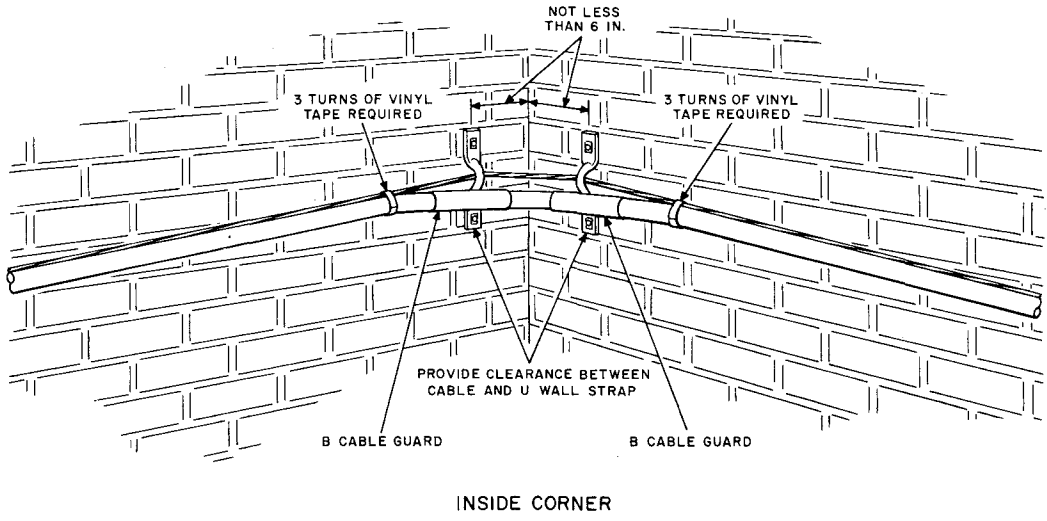

Fig. 5—Inside Corners (Masonry Structures)

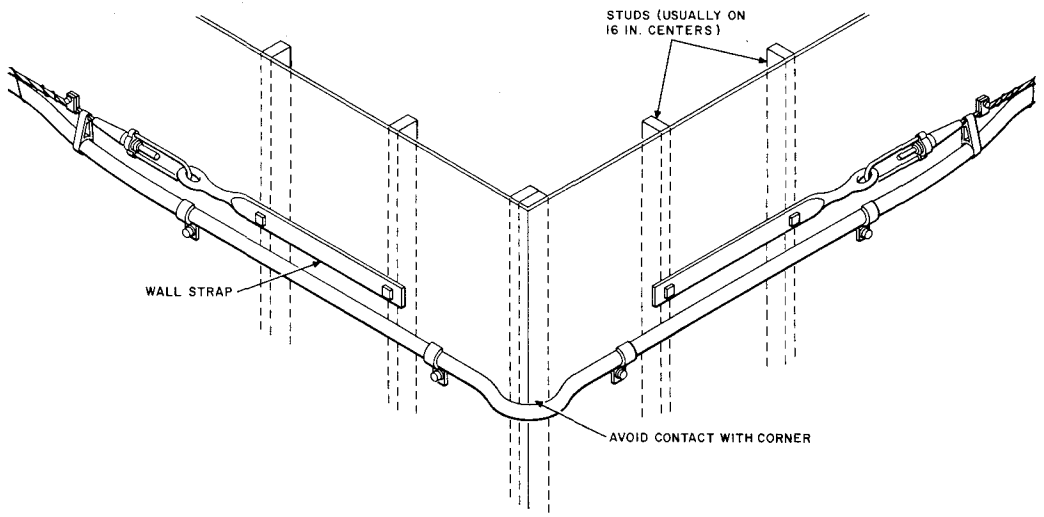

Fig. 6—Outside Corners (Frame Structures)

**CABLE CLAMPED DIRECTLY TO WALLS**

**3.07** When clamping cable directly to walls it is desirable to complete all drilling operations in a cable section before starting to place cable. On straight runs, either horizontal or vertical, stretch a chalk line and mark the wall to show

where cable is to be placed. Select points close enough and be sure line is tight to avoid any appreciable sag in the cable run.

**3.08** A typical installation for clamping a cable directly to an exterior wall surface is shown in Fig. 7. Space cable clamps approximately 24 inches apart.

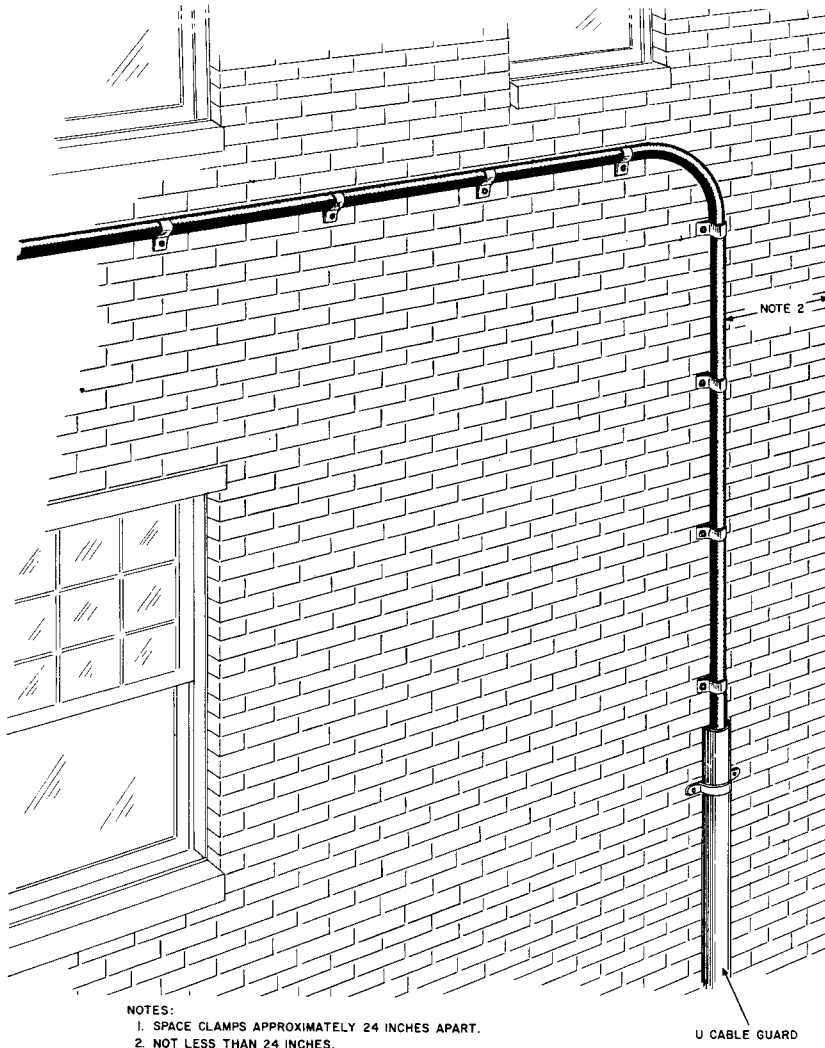

**Fig. 7—Cable Clamped to Exterior Wall**

3.09 When cable clamps are used to support cable on outside corners, provide sufficient clearance to avoid contact with corner as shown in Fig. 8.

3.10 When supporting cable on inside corners using cable clamps, use method shown in Fig. 9.

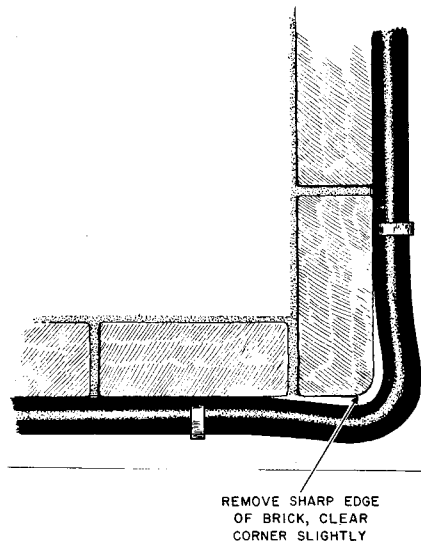
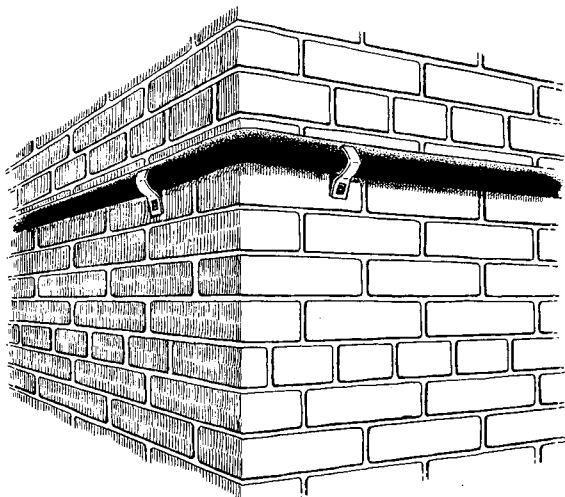
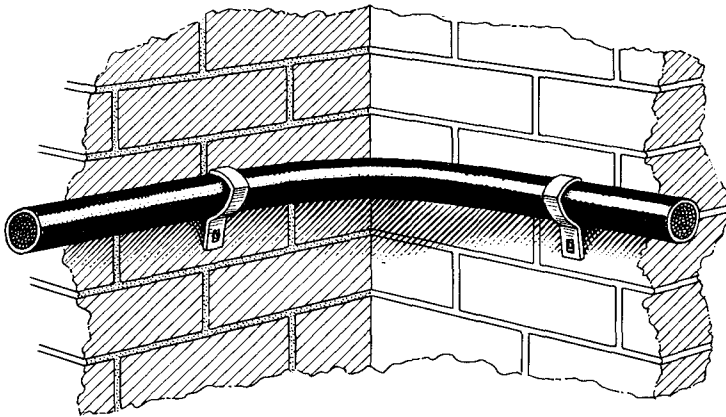
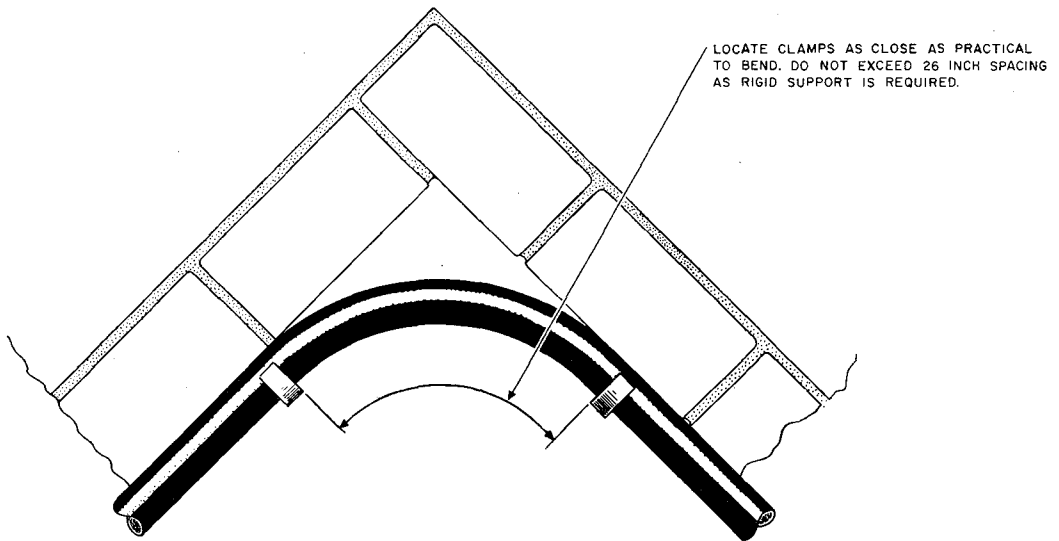

Fig. 8—Making Outside Corners with Cable Clamps



CABLES LARGER THAN 1 INCH OD—  
INSIDE CORNER

Fig. 9—Making Inside Corners with Cable Clamps

#### BUILDING-TO-BUILDING SPANS

3.11 Limit cable spans between buildings to a maximum of 100 feet in length. Care should be exercised in selecting a structure substantial enough to withstand the strain of a tensioned cable.

3.12 In erecting the span, remove the curvature in the strand that results from uncoiling it. Attach the strand to the wall strap or bracket and tension with a chain hoist. As tension is applied observe the walls or structure carefully for cracks or other failures indicating that the strain is too great.

3.13 The final tension in the strand should be approximately 300 pounds for 2.2M strand and 600 pounds for 6M and 6.6M strand. These tensions may be approximated by stringing the strand with the sags shown in Table E.

3.14 For determining the sags with cable in place, refer to Table F.

3.15 Where spans between buildings are 40 feet or less, no special hardware is required (Fig. 10).

**TABLE E**  
**TENSIONING CABLE IN BUILDING-TO-BUILDING SPANS**

SPAN IN FEET	2.2M STRAND		6M STRAND		6.6M STRAND	
	SAG (IN)	TENSION (LB)	SAG (IN)	TENSION (LB)	SAG (IN)	TENSION (LB)
40	1/2	375	1	540	4	520
60	1	420	2	610	8	590
80	2	375	4	540	12	695
100	3	390	6	560	17	760

**TABLE F**  
**APPROXIMATE SAGS WITH CABLE IN PLACE<sup>1</sup>**

SIZE OF STRAND	WEIGHT OF CABLE PER FOOT (POUNDS)	SAG IN INCHES WITH SPANS OF:			
		40 FEET	60 FEET	80 FEET	100 FEET
2.2M	Up to .5	3	7	12	17
	.5 to .75	4	8	14	19
	.75 to 1.0	5	9	16	21
	1.0 to 1.25	6	11	18	24
	1.25 to 1.5	7	12	19	26
6M	Up to .5	3	5	9	13
	.5 to .75	3	6	10	15
	.75 to 1.0	4	8	12	17
	1.0 to 1.25	4	9	13	18
	1.25 to 1.5	5	10	14	19
	1.5 to 1.75	5	10	15	20
	1.75 to 2.0	5	10	16	21
	2.0 to 2.25	6	11	16	22
	2.25 to 2.5	6	11	17	23
	2.5 to 2.75	7	12	17	24
2.75 to 3.0	7	12	18	25	

**Note 1:** For cables tensioned in accordance with Table E

## NOTES:

1. NOT LESS THAN 24 IN.
2. WHERE THE ATTACHMENTS ARE OUT OF LINE HORIZONTALLY, THE STRAND IN THE BRACKETS SHALL BE IN SUCH A POSITION THAT CABLE WHEN IN PLACE SHALL CLEAR THE BUILDING WALL.

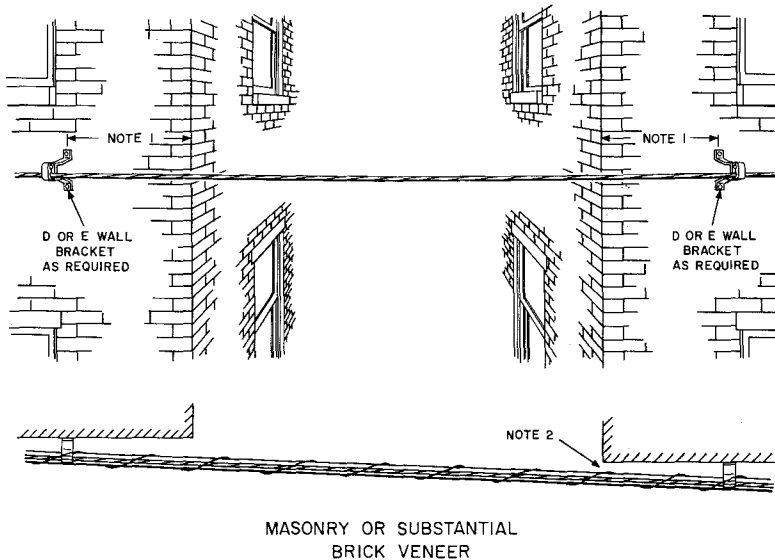

**Fig. 10—Building-To-Building Span (40 feet or less)**

**3.16** Where the span between buildings is greater than 40 feet a C Wall Bracket shall be used for support as shown in Fig. 11.

**3.17** It is preferable to run cables between buildings on a horizontal line. This sometimes necessitates a change in grade. Fig. 12 shows the recommended method where a cable spans between two buildings of different heights.

#### **4. INTERMEDIATE AND DEAD-END ATTACHMENTS ON INSIDE WALLS**

**4.01** The procedures for attaching cable to inside walls is basically the same as that used for outside walls as described in Part 3.

**4.02** On longer runs it is usually advantageous to use suspension strand rather than attaching directly to walls for the following reasons:

- Reduced number of attachments and drilling required.
- Clearing obstructions such as pipes and conduit
- Plaster or similar wall projections materially lengthen the amount of cable required when attached directly to walls.

**4.03** When passing cable through walls, drill hole only large enough to accommodate the cable. Seal space around cable with hydraulic cement.

**4.04** The minimum bending radius for cable is computed by multiplying the cable diameter by 6, eg, a cable with a one-inch diameter would have a minimum bending radius of 6 inches.

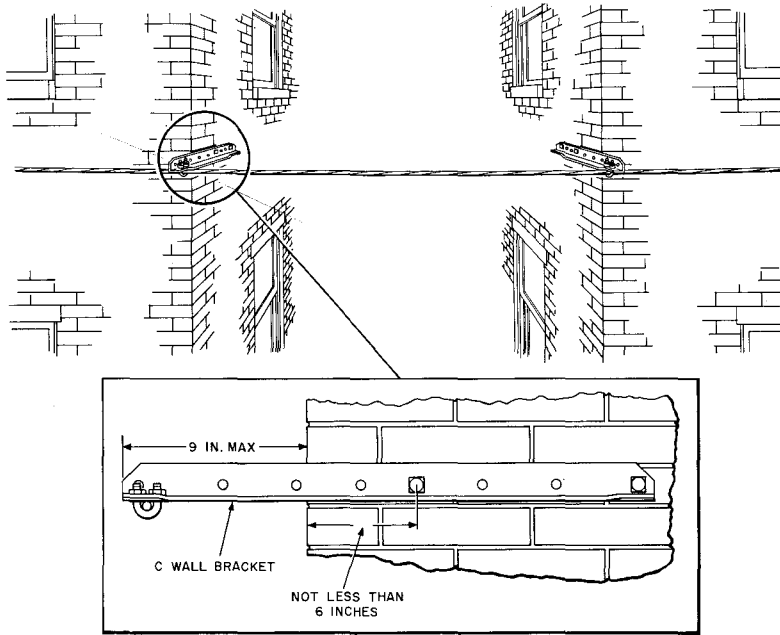

Fig. 11—Building-To-Building Span (greater than 40 feet)

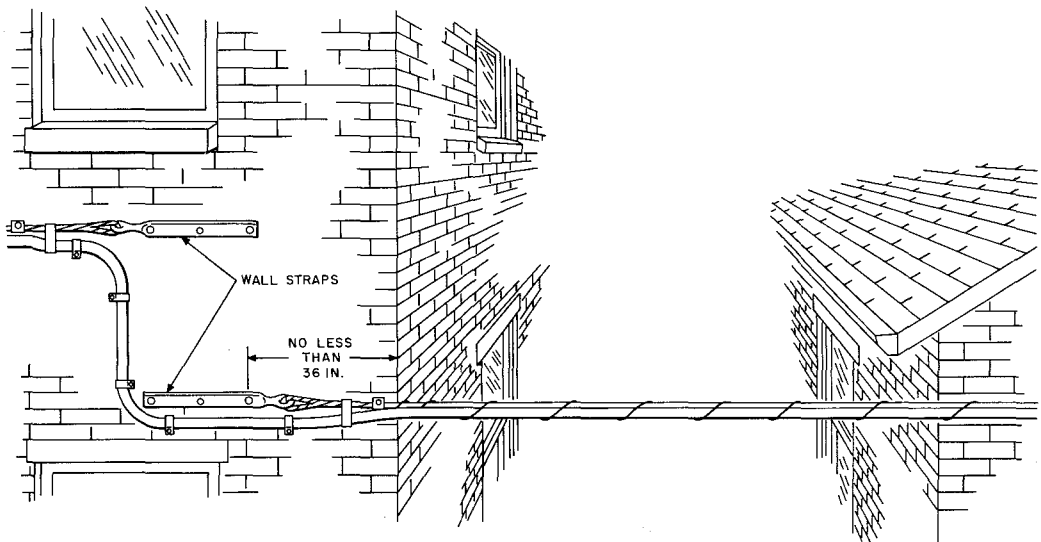

Fig. 12—Building-To-Building Span (change in grade)



**STRAND SUPPORTED CABLE**

**4.05** Use 2.2M strand for cables weighing 1-1/2 pounds per foot or less and 6M strand for cables weighing more than 1-1/2 pounds per foot.

**4.06** Cables rings may be used in lieu of lashing wire where it is impractical to use the ZB Cable Lasher because of obstructions.

**4.07** Dead end strand on walls as shown in Fig. 13.

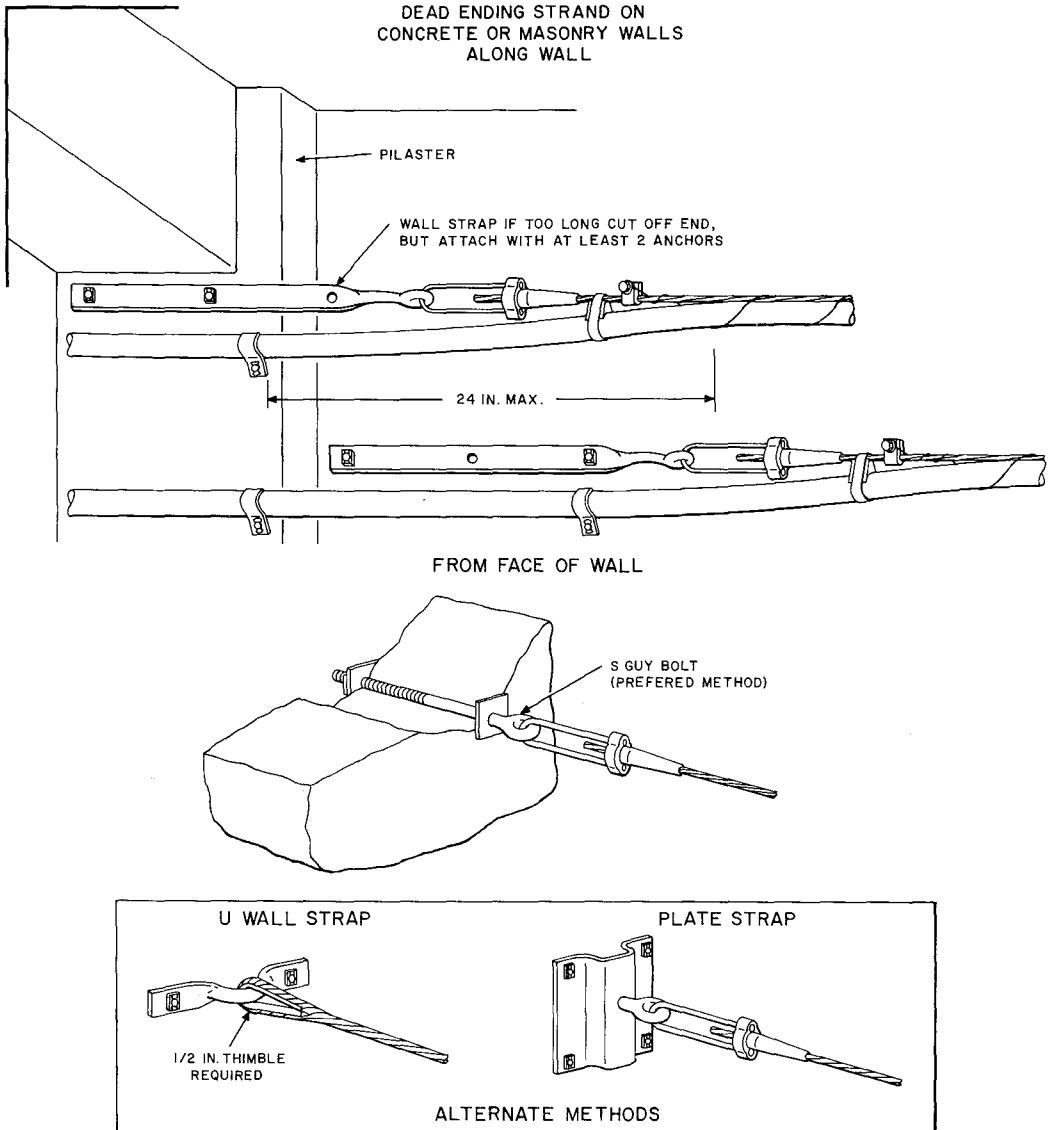

4.08 Dead end strand on ceilings or overhead beams as shown in Fig. 14.

4.09 The recommended method for intermediate attachments to interior walls is shown in Fig. 15. Space the S and L Wall Brackets approximately 40 feet apart.

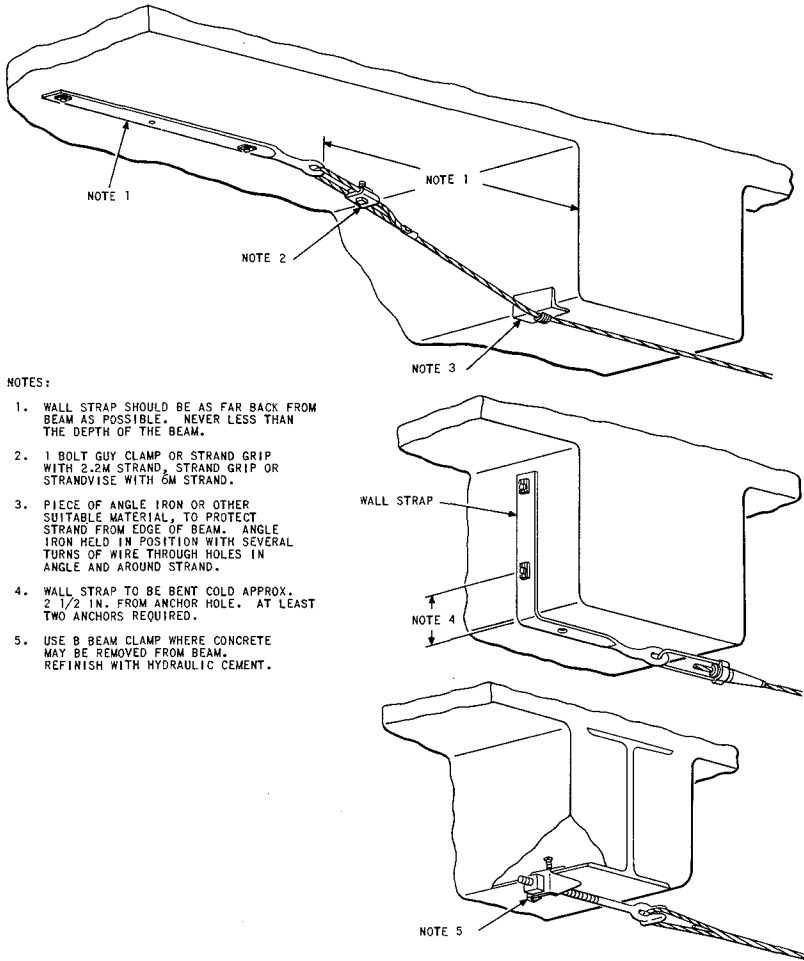

Fig. 14—Dead Ending Strand on Ceilings and Overhead Beams

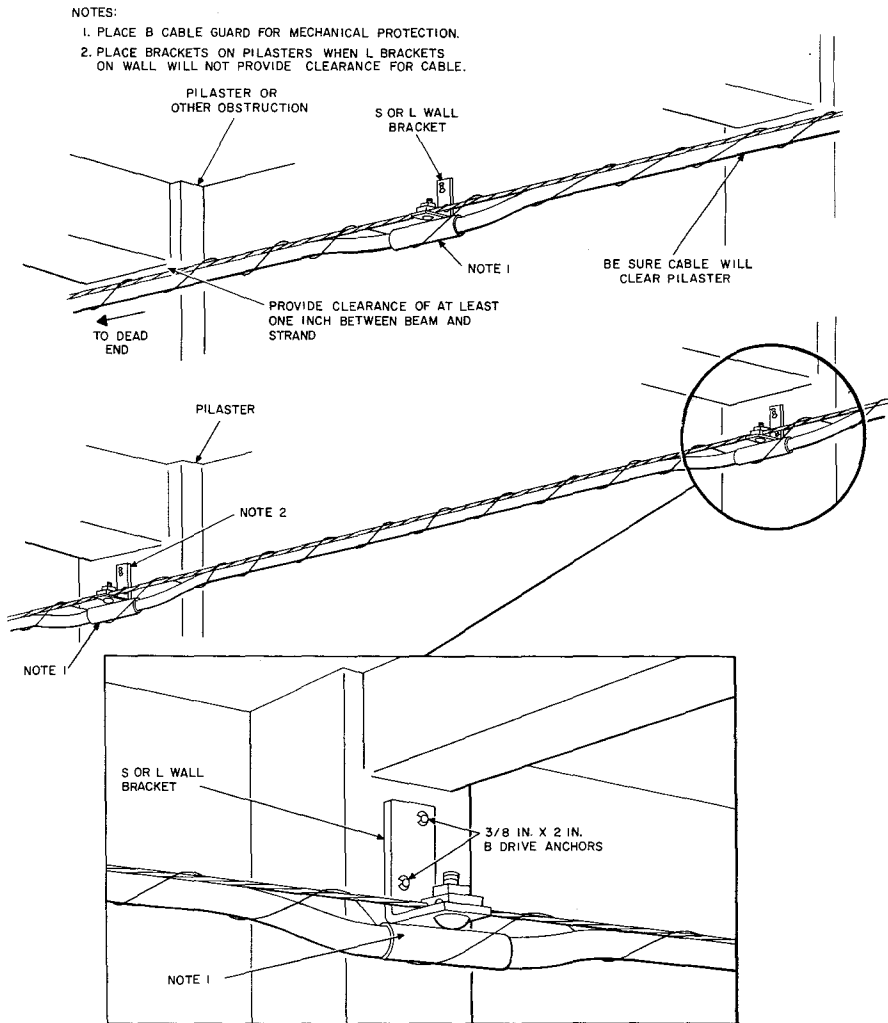
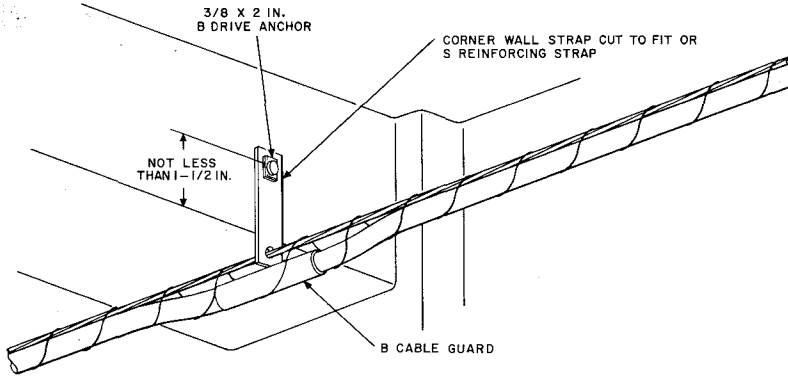

Fig. 15—Intermediate Attachments To Masonry Walls

4.10 Typical intermediate attachments to overhead beams and ceilings are shown in Fig. 16.

4.11 The recommended methods for making inside and outside corners with strand supported cable are shown in Fig. 17 and 18.



NOTE:  
INSTALL STRAP TO PROVIDE AT LEAST 1 INCH CLEARANCE FROM UNDERSIDE OF BEAM. DISTANCE BETWEEN SUPPORTS SHALL BE APPROXIMATELY 40 FT.

ATTACHMENTS ON BEAMS

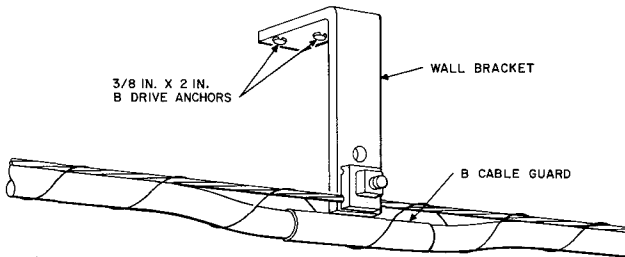

NOTE:  
IN CASES WHERE AN L WALL BRACKET IS NOT LONG ENOUGH TO RESULT IN A LEVEL CABLE RUN, THE STRAND MAY BE LASHED TO THE STRAP AS SHOWN BELOW.

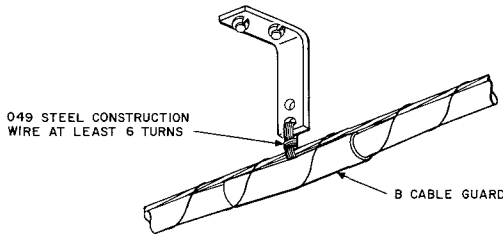

ATTACHMENTS TO CEILINGS

Fig. 16—Intermediate Attachments To Ceilings

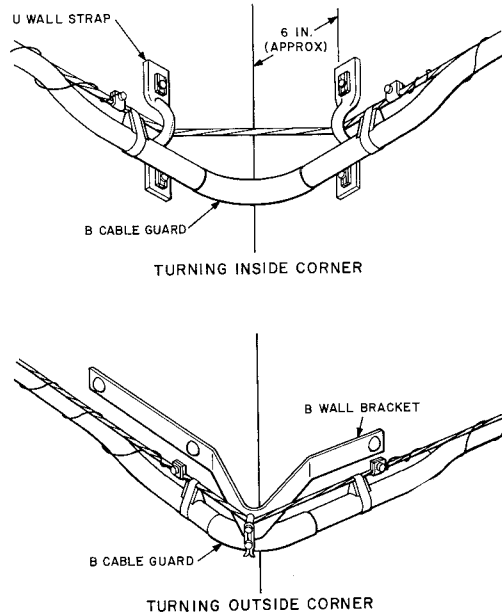

**Fig. 17—Inside and Outside Corners**

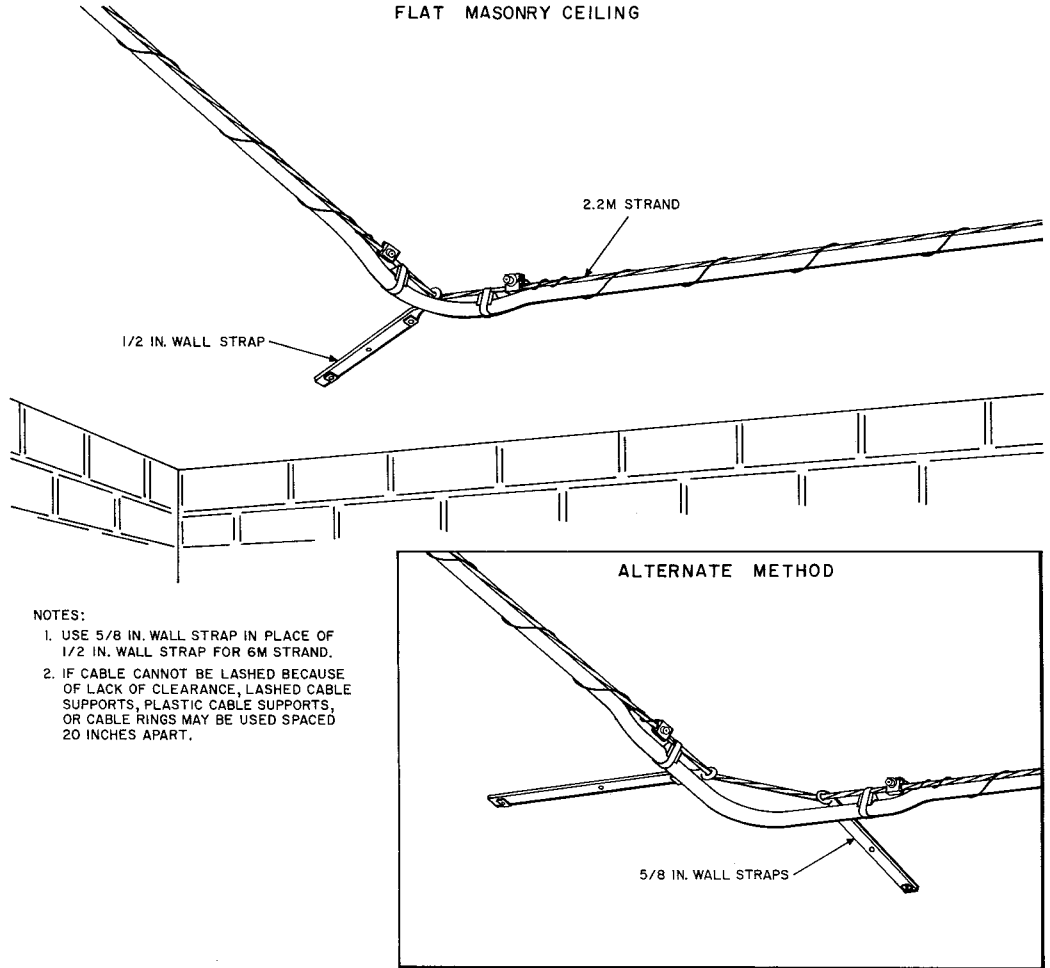

Fig. 18—Flat Masonry Ceilings

**CABLE CLAMPED DIRECTLY TO WALLS AND CEILINGS**

4.12 The procedures for clamping cables to inside walls is basically the same as for outside walls (see 3.08).

4.13 For determining the proper type of anchoring device to be used with cable clamps, refer to 627-610-200.

4.14 Where wood frame structures are involved attach a cable clamp to each wall stud or ceiling beam. Fig. 19 shows the various methods of attachment used on the most common types of building structures.

4.15 In areas where appearance will not be objectionable, plastic sheath cable may be

attached to electric conduit or *cold* water pipes with the use of Plastic Cable Supports as shown in Fig. 20. Do not use hot water pipes. Space plastic cable supports approximately 24 inches apart.

4.16 When it is necessary to parallel the main cable with a branch cable or terminal stub, they may be attached with cable clamps or plastic cable supports as shown in Fig. 21.

4.17 When two cables are run parallel, it is desirable to place the smaller cable above the larger cable. If terminals are involved, place the terminal stub either below the main cable or above it depending on the location of the terminal in order to eliminate crossing the cable.

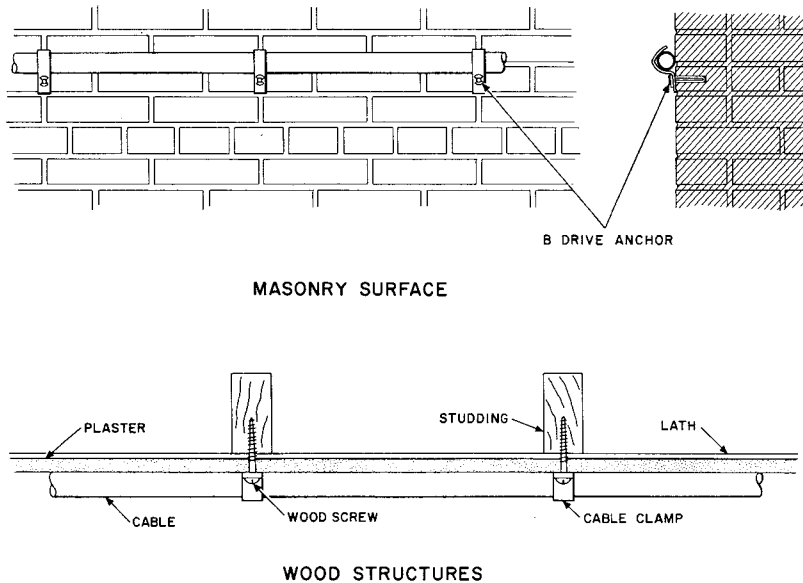

Fig. 19—Direct Attachment To Interior Walls (detail)

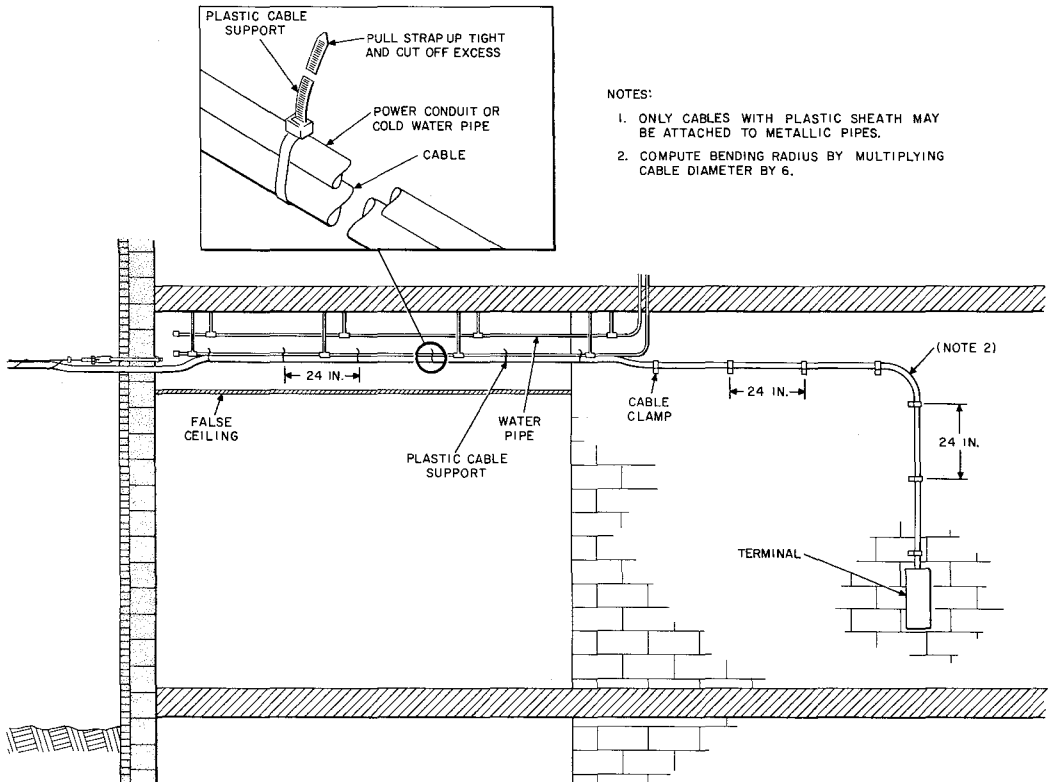

Fig. 20—Direct Attachment To Interior Walls (general)

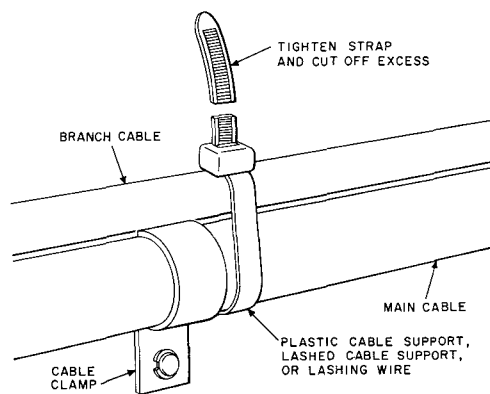
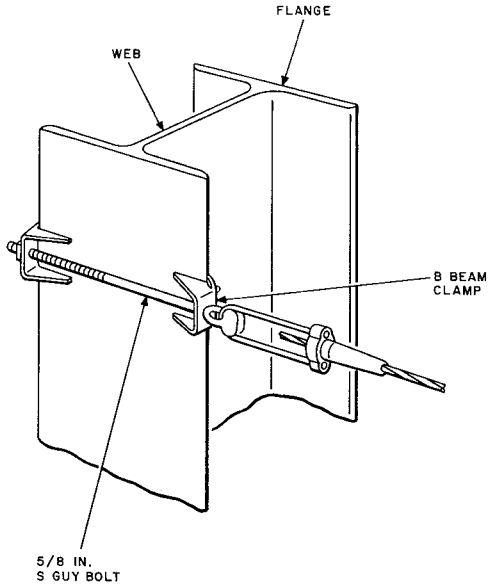

Fig. 21—Attaching Parallel Cable Runs



**ATTACHMENTS TO STRUCTURAL STEEL FRAMEWORK**

**4.18** Due to the variety of steel construction encountered in the field the methods suggested in this section should be used as a guide which may require modifications to fit specific conditions.



**Fig. 22—Dead Ending Strand on Steel Columns**

**DEAD ENDING**

**4.19** The methods for dead ending strand to steel columns and beams are shown in Fig. 22 through 24.

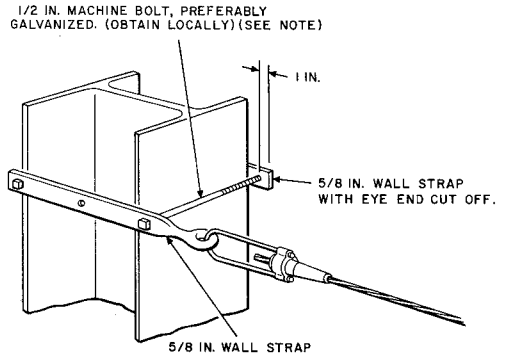

**NOTE:**  
BOLT SHOULD PROJECT MORE THAN ONE INCH FROM SURFACE OF COLUMN. IF EXISTING HOLES IN WALL STRAP DO NOT PERMIT THE BOLTS TO FIT SNUGLY AGAINST COLUMN DRILL NEW 11/16 IN. HOLES.

**Fig. 23—Dead Ending Strand on Steel Columns (straps)**

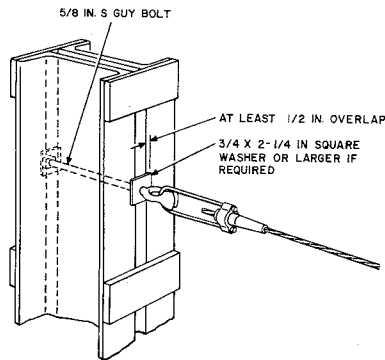
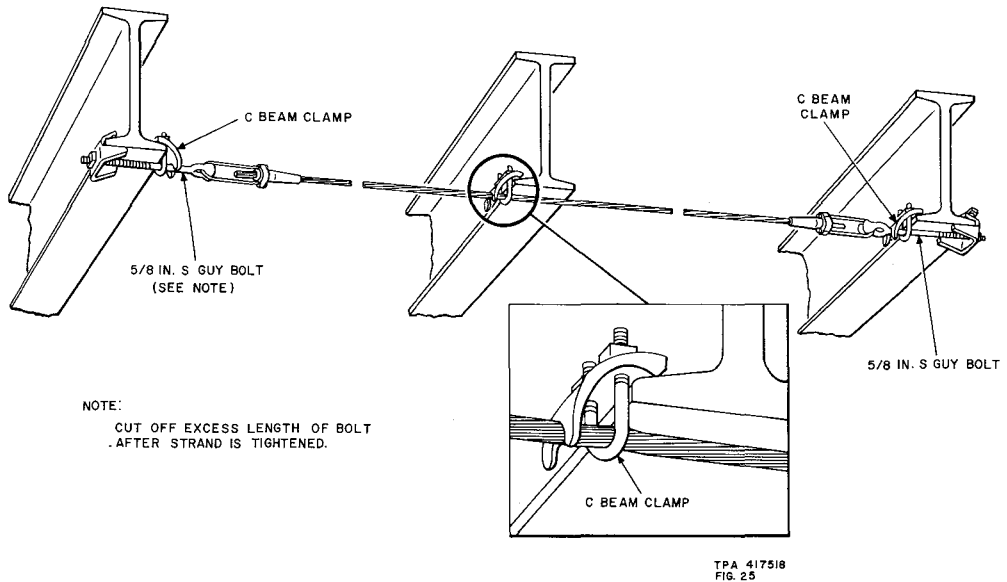

**Fig. 24—Dead Ending Strand on Built-up Columns**

4.20 Fig. 25 illustrates the method of attaching to overhead steel I Beams. Locate dead-ending attachments as close to vertical ceiling support as practical.

**INTERMEDIATE SUPPORTS**

4.21 Intermediate attachments to the flanges of columns and beams are illustrated in Fig. 26 through 28. Locate intermediate supports approximately 40 feet apart.



**Fig. 25—Placing Strand on Overhead Beams**

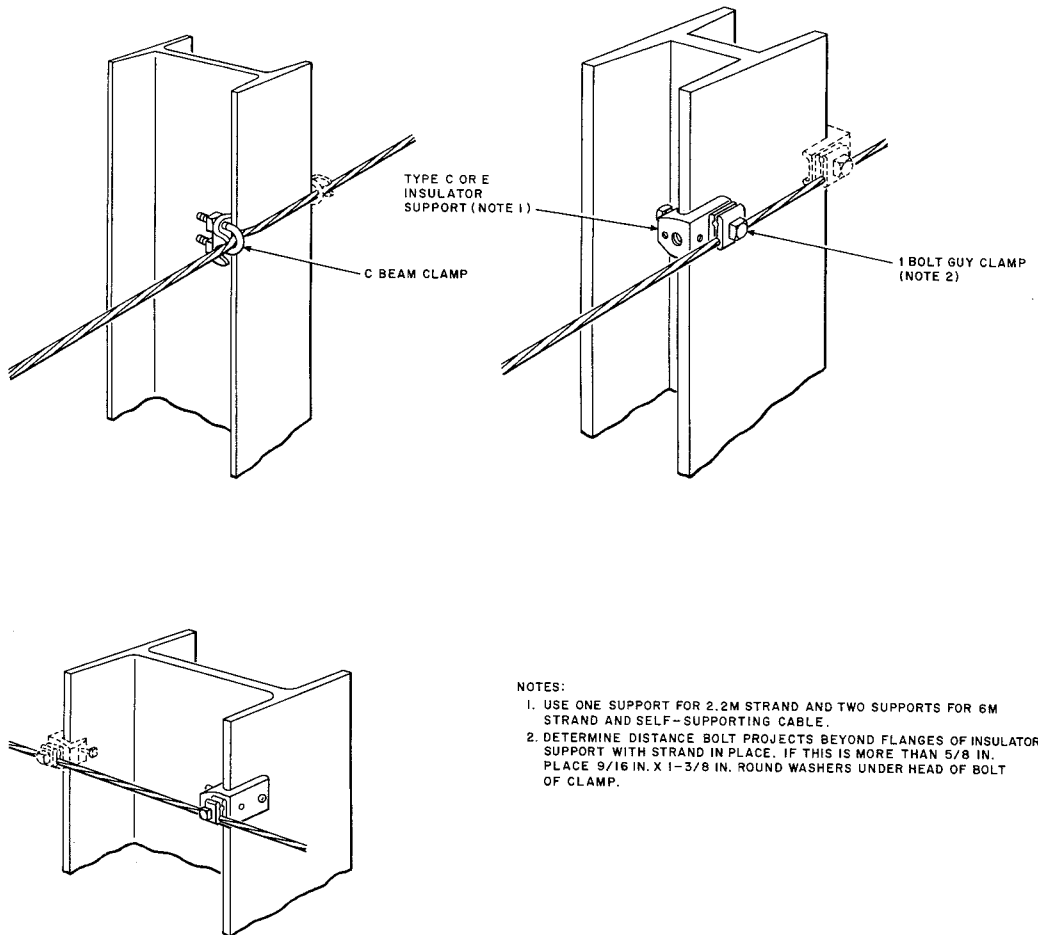

**Fig. 26—Intermediate Attachments To Steel Columns**

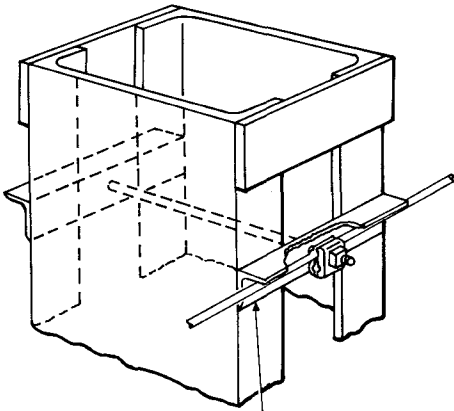

NOT LESS THAN 2 IN. X  
2 IN. X 3/16 IN. ANGLE IRON OR  
2 1/2 IN. X 1/4 IN. FLAT STEEL  
STRAP (OBTAIN LOCALLY)

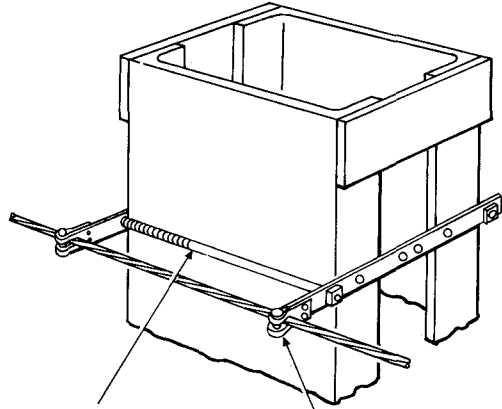

1/2 IN. MACHINE BOLT  
PREFERABLY GALVANIZED  
(OBTAIN LOCALLY)

CORNER  
WALL STRAP

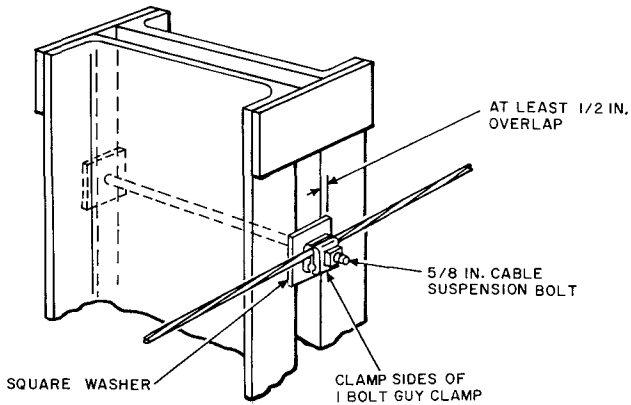

AT LEAST 1/2 IN.  
OVERLAP

5/8 IN. CABLE  
SUSPENSION BOLT

SQUARE WASHER

CLAMP SIDES OF  
1 BOLT GUY CLAMP

Fig. 27—Intermediate Attachments To Built-up Columns

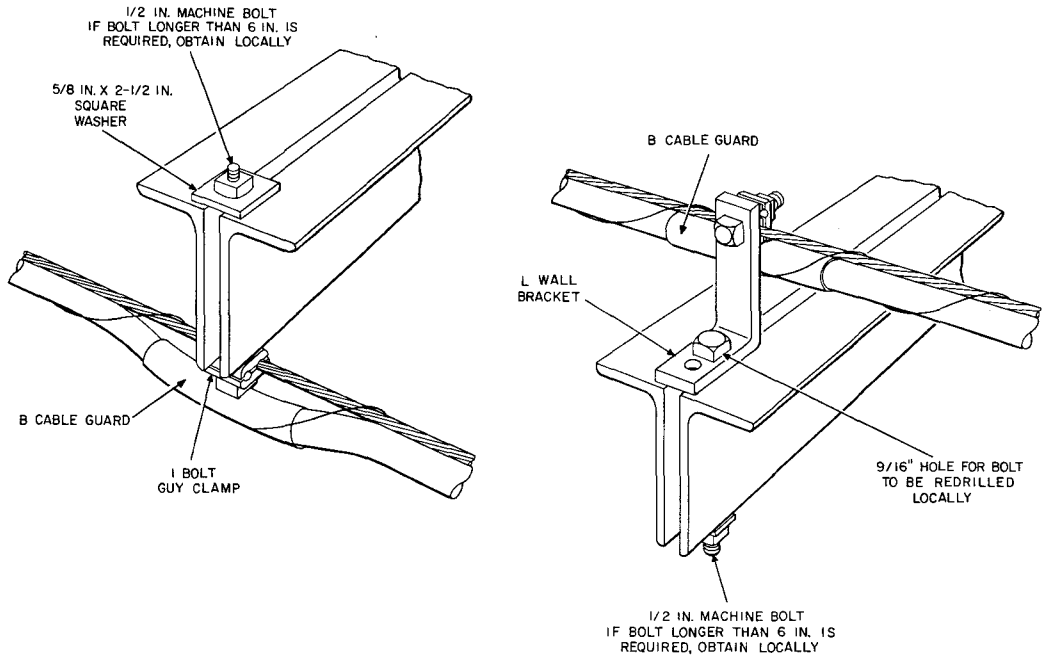
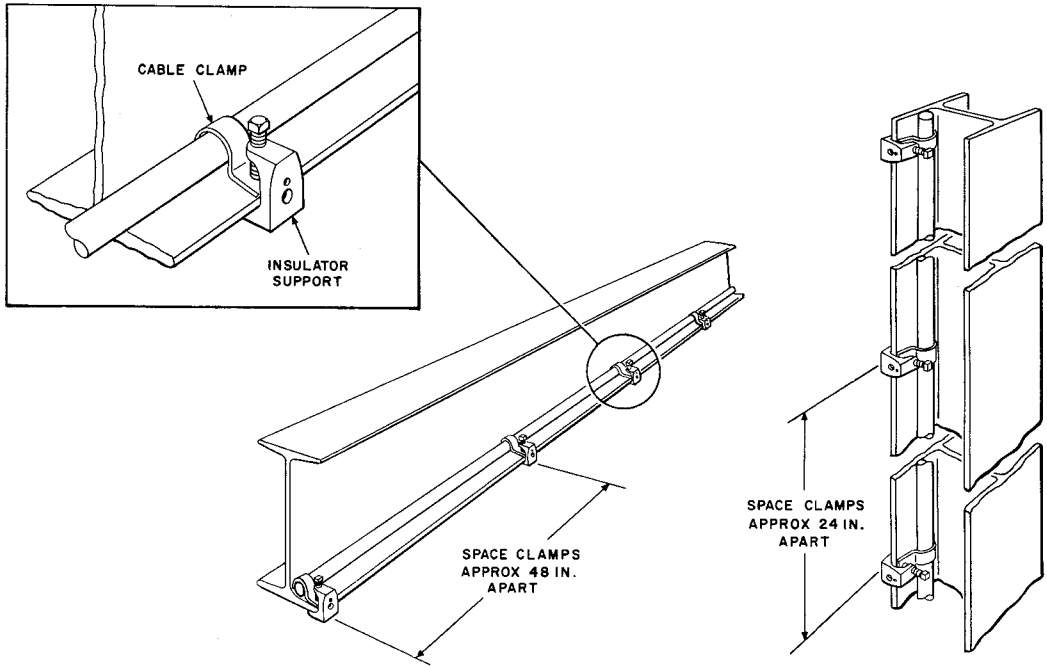

**Fig. 28—Intermediate Attachments To Overhead Beams**

**4.22** A cable may be run horizontally or vertically along steel columns and beams as shown in Fig. 29.

**4.23** The B Support Clip (Fig. 30) is used for mounting wood backboards on steel columns

with flanges up through 3/8 inch thick. When the flanges of the columns are greater than 3/8 inch in thickness, use an insulator support for mounting the backboards employing one of the methods shown in Fig. 31.



**Fig. 29—Cable Runs Along Steel Beams and Columns**

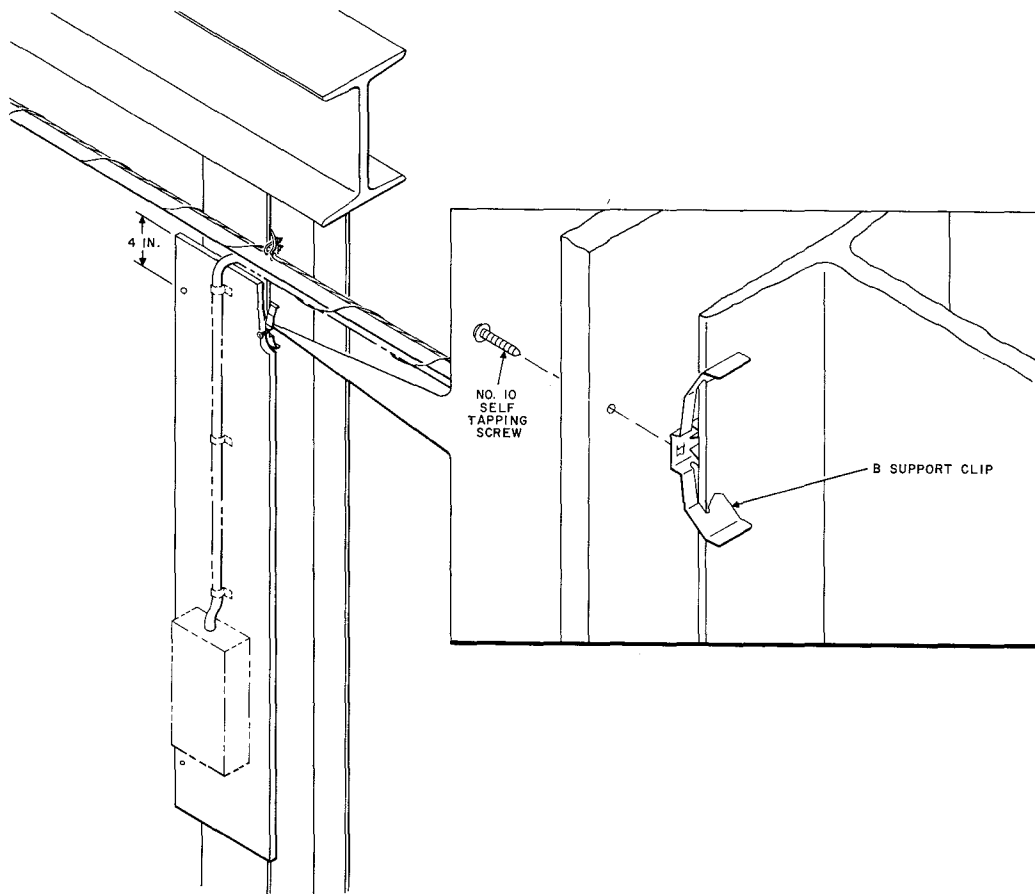

Fig. 30—Backboard Attached to Steel Columns Using B Support Clip

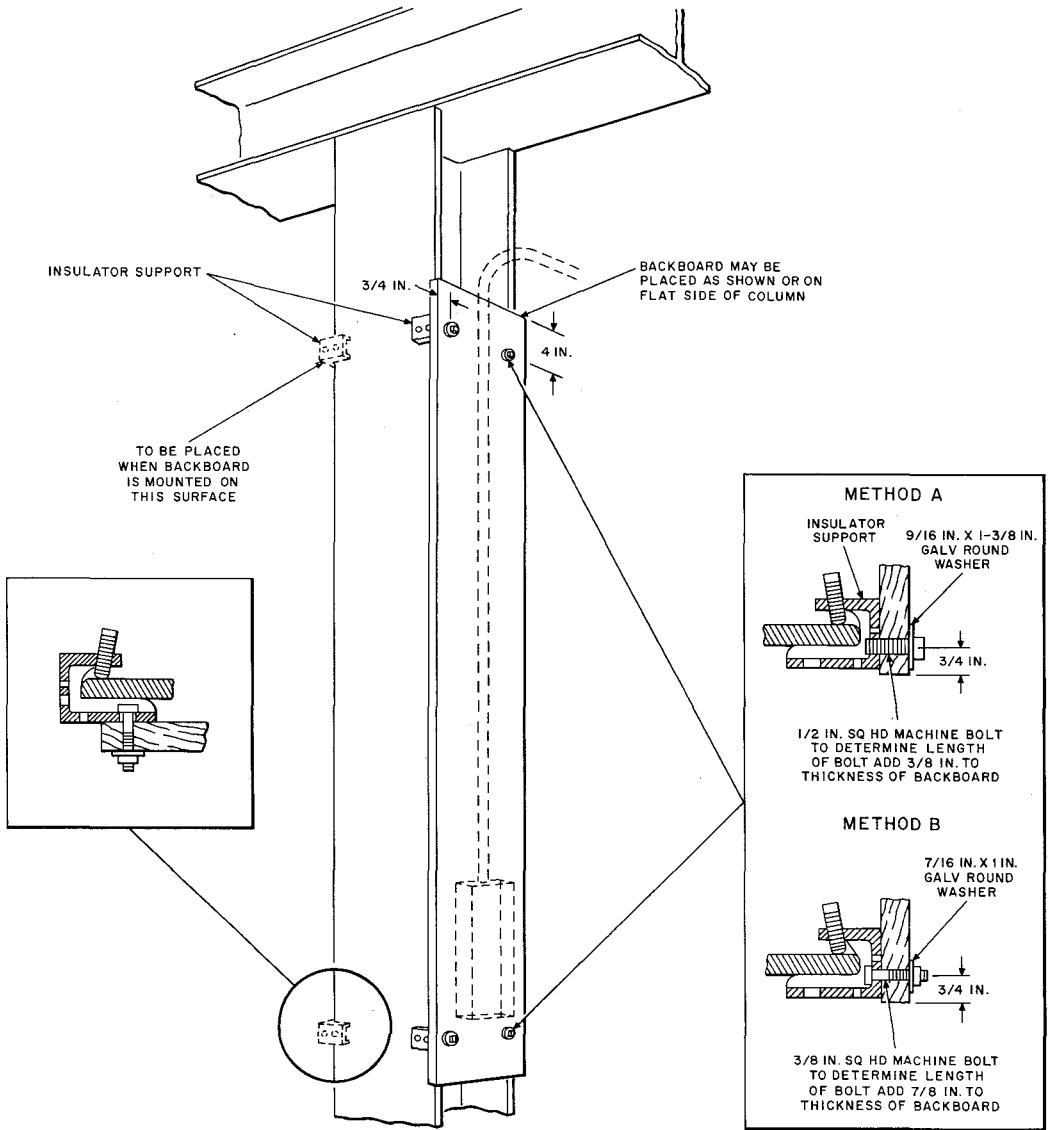

Fig. 31—Backboard Attached To Steel Columns Using Insulator Supports