

RUBBER CONDUIT PLUGS

CONTENTS	PAGE
1. GENERAL	1
2. DESCRIPTION AND USE—SOLID PLUGS	1
SQUARE SOLID RUBBER PLUGS	2
ROUND SOLID RUBBER PLUGS	2
3. DESCRIPTION AND USE—SPLIT PLUGS	3
SQUARE SPLIT RUBBER PLUGS	4
ROUND SPLIT RUBBER PLUGS	4
4. INSTALLATION—SOLID PLUGS	5
5. INSTALLATION—SPLIT PLUGS	6
6. REMOVAL	7
SOLID RUBBER PLUGS	7
SPLIT RUBBER PLUGS	7

1. GENERAL

1.01 This section covers the description and use of rubber conduit plugs used to seal the ends of conduit. These plugs will prevent the

entrance of fluids or gas from the conduit into manholes, cable vaults, or buildings.

1.02 This section is reissued to include descriptive information on the improved solid rubber plugs (square and round) which replace the solid rubber plugs currently in use. Since the changes to the solid rubber conduit plugs were made primarily for manufacturing considerations—a hollow, webbed body is used instead of a solid body—the ability of the current plugs to produce a water and gas tight seal in vacant ducts is equal to the new plugs.

1.03 Other methods for sealing occupied ducts are described in related sections. Refer to Section 628-800-305 for a description of split rubber conduit plugs used in conjunction with B sealing compound to prevent the creepage of cable in conduit sections.

2. DESCRIPTION AND USE—SOLID PLUGS

2.01 Solid rubber conduit plugs are used for sealing unoccupied ducts in manholes and cable vaults and to provide reinforcement for multiple unit conduit where cable creepage treatment is used as described in Section 628-800-305. Solid rubber plugs are available for use in square or round bore ducts in sizes to accommodate all types of standard conduit. Plug sizes are designated by duct dimension and duct type (round or square).

NOTICE

This document is either
AT&T - Proprietary, or WESTERN
ELECTRIC - Proprietary
Pursuant to Judge Greene's Order of August 5, 1963,
beginning on January 1, 1964, AT&T will cease to use
"Bell" and the Bell symbol, with the exceptions set out
forth in that Order. Pursuant thereto, any reference to
"BELL" and/or the BELL symbol in this document is here-
by deleted and "expunged".

SQUARE SOLID RUBBER PLUGS

2.02 The square solid rubber conduit plug (Fig. 1) consists of a soft, expandable, rubber center section between two zinc coated steel compression plates assembled with a 3/8-inch carriage bolt and square nut. A square hole in the center of the steel plate conforms to the square shoulder of the carriage bolt to prevent the bolt from turning when the nut is tightened.

2.03 Refer to Table A for the size of square plug required for the size and type of conduit involved.

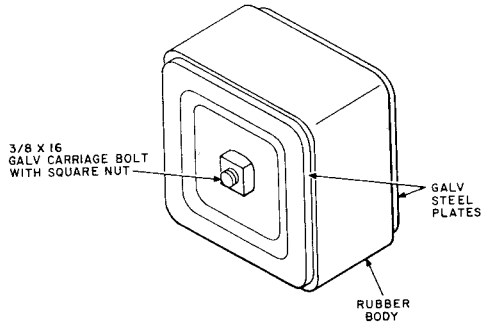

ROUND SOLID RUBBER PLUGS

2.04 The round solid rubber plug is identical in construction to the square solid rubber plug except for the circular design of the steel plates and rubber center section (Fig. 1).

2.05 Refer to Table A for the size of round plug required for the size and type of conduit involved.

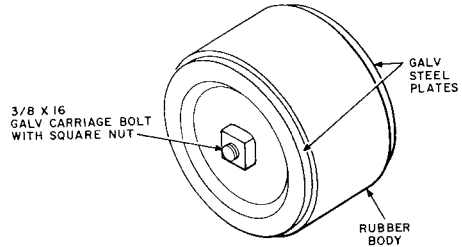

Fig. 1—Solid Rubber Conduit Plugs

TABLE A

SOLID RUBBER CONDUIT PLUGS							
TYPE OF CONDUIT	CONDUIT AND PLUG SIZES (INCHES)						TYPE OF PLUG
	3	3½	3¾	4	4¼	4½	
Plastic Pipe				X			Round
Steel Pipe	X		X	X		X	Round
Sewer Pipe	X			X			Round
B or C Fiber	X		X	X			Round
B or Cement-Fiber	X		X	X			Round
B or C Concrete			X	X			Round
D or E Concrete			X	X			Round
F or G Concrete			X	X			Round
Multiple Clay		X		X	X		Square

Note: See 2.06.

2.06 To seal the auxiliary holes in 4-inch concrete conduit, 1-1/4 and 1-5/16 inch solid round rubber conduit plugs are available from:

- F. H. Maloney Co., Houston, Texas
- Kohler and Besser Electronics, Inc., Rolling Meadows, Illinois

3. DESCRIPTION AND USE—SPLIT PLUGS

3.01 The split rubber plugs are used for sealing the ends of ducts occupied by cables. In the split rubber plug the rubber portion is molded to fit cables of varying diameters. The plug has a diagonal cut in one wall to allow it to be placed over the cable and is furnished with sectional galvanized steel plates shaped to conform to the plug. Compression of the rubber is accomplished

by means of 1/4-inch carriage bolts which extend through the plates and the rubber portion of the plug.

3.02 Plug sizes are designated by duct dimension and type (round or square) and by the nominal diameter of the largest cable for which the plug is designed. Each plug is adaptable to a range of cable sizes, as indicated in Tables B and C. The plugs possess sufficient flexibility to permit some overlap of ranges so that a plug designed for a certain range of cable diameters frequently can be used on the larger cables of the next lower range and on the smaller cables of the next higher range. As an example of the way in which this flexibility can be used to advantage, if difficulty is encountered in obtaining a seal with the plug of indicated size, try the next smaller size to make use of the increased expansion provided by the heavier wall thickness.

TABLE B

SQUARE SPLIT RUBBER CONDUIT PLUGS					
DUCT SIZE* (INCHES)	CABLE DIAMETER (INCHES)*		SQUARE SPLIT PLUG DATA		TYPE FIG. 2 DESIG.
	MIN	MAX	OUTSIDE	INSIDE	
3-1/4	0.50	1.06	3-1/4	1-1/16	A
3-1/4	1.13	1.63	3-1/4	1-5/8	A
3-1/4	1.69	2.06	3-1/4	2-1/16	A
3-1/4	2.13	2.41	3-1/4	2-13/32	A
3-1/4	2.44	2.63	3-1/4	2-5/8	A
3-1/4	2.69	2.81	3-1/4	2-13/16	B
4	0.50	1.06	4	1-1/16	A
4	1.13	1.63	4	1-5/8	A
4	1.69	2.06	4	2-1/16	A
4	2.13	2.41	4	2-13/32	A
4	2.44	2.63	4	2-5/8	A
4	2.69	2.81	4	2-13/16	B
4	2.85	3.13	4	3-1/8	B
4-1/4	0.50	1.00	4-1/4	1	A
4-1/4	2.44	2.63	4-1/4	2-5/8	A
4-1/4	2.69	3.13	4-1/4	3-1/8	B

* Plug size is designated by duct dimension and the maximum cable diameter for which the plug is designed. For example: specify a 4 by 2-5/8 inch square split conduit plug for 4-inch square bore conduit where the cable diameter is in the range of 2.44 to 2.63 inches. Use B Measuring Tape to determine cable diameter.

TABLE C

ROUND SPLIT RUBBER CONDUIT PLUGS					
DUCT SIZE* (INCHES)	CABLE DIAMETER* (INCHES)		ROUND SPLIT PLUG DATA		TYPE FIG. 3 DESIG.
	MIN	MAX	DIMENSION (INCHES) OUTSIDE	INSIDE	
3	0.50	1.06	3	1-1/16	C
3	1.13	1.63	3	1-5/8	C
3	1.69	2.00	3	2	D
3-1/2	0.50	1.06	3-1/2	1-1/16	C
3-1/2	1.13	1.63	3-1/2	1-5/8	C
3-1/2	1.69	2.06	3-1/2	2-1/16	C
3-1/2	2.13	2.44	3-1/2	2-7/16	D
4	0.50	1.06	4	1-1/16	A
4	1.13	1.63	4	1-5/8	A
4	1.69	2.06	4	2-1/16	A
4	2.44	2.63	4	2-5/8	A
4	2.69	2.81	4	2-13/16	B
4	2.88	2.94	4	2-15/16	B
4	2.85	3.06	4	3-1/16	B
4-1/2	0.50	1.06	4-1/2	1-1/16	A
4-1/2	2.13	2.81	4-1/2	2-13/16	A
4-1/2	2.69	3.13	4-1/2	3-1/8	A

* Plug size is designated by duct dimension and the maximum cable diameter for which the plug is designed. For example: specify a 4 by 2-15/16 inch round split conduit plug for 4-inch round bore conduit where the cable diameter is in the range of 2.88 to 2.94. Use B Measuring Tape to determine cable diameter.

SQUARE SPLIT RUBBER PLUGS

3.03 The square split rubber plug shown in Fig. 2(A) is used for sealing all sizes of cables up to and including those of 2-5/8 inch diameter in 3-1/4 inch square bore conduit.

3.04 For sealing a duct containing a cable larger than 2-5/8 inches in diameter, the type of plug shown in Fig. 2(B) is required. The restricted space between such a cable and the duct walls requires the use of elongated bolts with pipe spacers to make the nuts accessible to the split conduit plug wrench.

3.05 Refer to Table B for the size of square plug required for the size and type of conduit involved.

ROUND SPLIT RUBBER PLUGS

3.06 The round split rubber plugs shown in Fig. 3 are used for sealing cables in single or multiple round bore conduit.

3.07 In sealing a duct containing a relatively large size cable, the type of plug shown in Fig. 3(B or D) is required. The restricted space limitations between cable and duct walls requires the use of elongated bolts. See 3.04.

3.08 Refer to Table C for the size of round split rubber plug required for the size of conduit and cable involved.

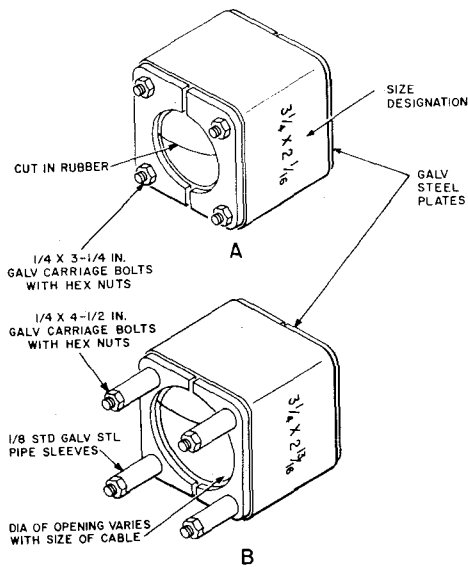

Fig. 2—Square Split Rubber Conduit Plugs

4. INSTALLATION—SOLID PLUGS

4.01 Select the proper size square or round solid rubber plug from Table A. Remove any dirt, grease, or loosely adhering material from the duct end and from the surfaces of the plug. With the bolt and washers in place, insert the plug into the duct with the nut outward and to a depth such as to afford the best bearing surfaces and permit effective use of the wrench in tightening the nut. The plug should be inserted far enough into the duct to clear the bevel and beyond any large cracks or chipped areas that may exist in the walls or webs of conduit.

4.02 Using a wrench suitable for use with a 3/8-inch nut, turn the nut until the rubber is expanded firmly against the duct walls. Avoid tightening to a point that the rubber bulges out around the edges of the compression plates; such pressure can crack the duct wall.

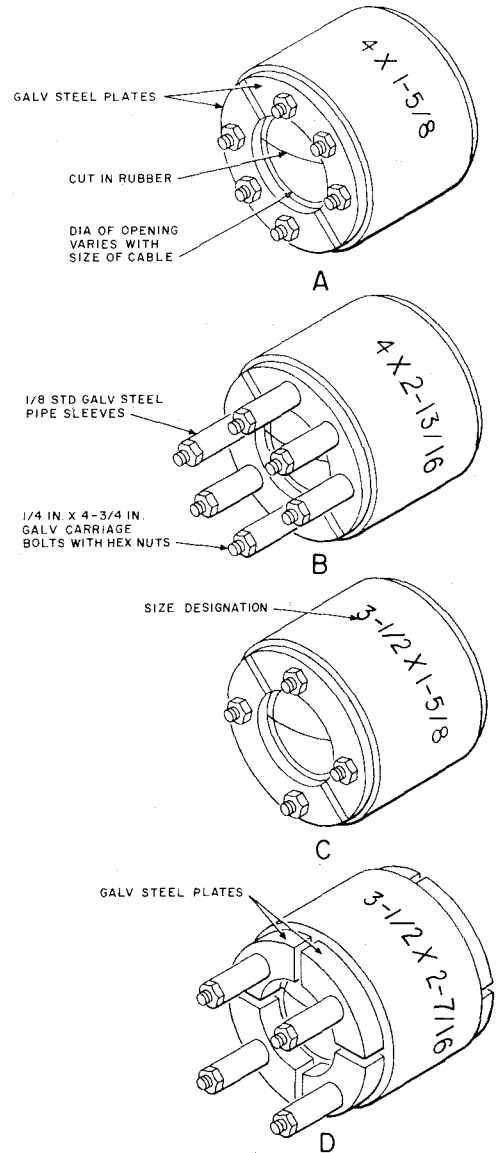

Fig. 3—Round Split Rubber Conduit Plugs

5. INSTALLATION—SPLIT PLUGS

5.01 Select the proper size and type of split rubber plug from Tables B or C. Before installing split rubber conduit plugs, examine the duct and remove any rough spots or accumulations of grease or silt. Inspect the cable for kinks just inside the duct, as the existence of such kinks will determine to some extent the depth to which the plug is to be placed in the duct. Minor indentations of the sheath will be sealed by the plug, but when deep kinks are found, it may be necessary to place the plug beyond the kink or to use an alternative method of sealing to obtain water-tightness.

5.02 Inspect the split rubber plug to see that the parts are properly assembled, with the nuts all in the same end and with the split in the rubber covered by a section of metal plate at each end. Examine the nuts to see that they are free and not compressing the rubber.

5.03 To place a square split plug on a cable, remove one of the bolts holding the plates covering the split in the rubber. To place the round split plugs shown in Fig. 3A and B, two bolts must be removed to uncover the split in the rubber. Swing these plates on the remaining bolt to uncover the split in the rubber. Spread the rubber as illustrated in Fig. 4 and slip the plug over the cable with the nuts facing outward.

Note: In the case of a round split plug having four steel plates at each end [Fig. 3(D)] the bolt to be removed temporarily is the one that passes through the slit in the rubber.

5.04 Restore the plates to position and replace the bolt and nut. When the cable is out of round, place the plug so the openings between the end plates are in line with the short diameter of the cable. This same procedure should be followed when the bend in the cable extends into the duct.

5.05 Slide the plug along the cable and into the duct. If difficulty is experienced in sliding the plug into the duct, apply E pressure testing solution as a lubricant to the cable and the inside of the plug. After the plug has been started in the duct, it will usually be found possible to insert it completely by the application of steady pressure. If it is necessary to apply additional force, proceed carefully to avoid damage to the sheath by the

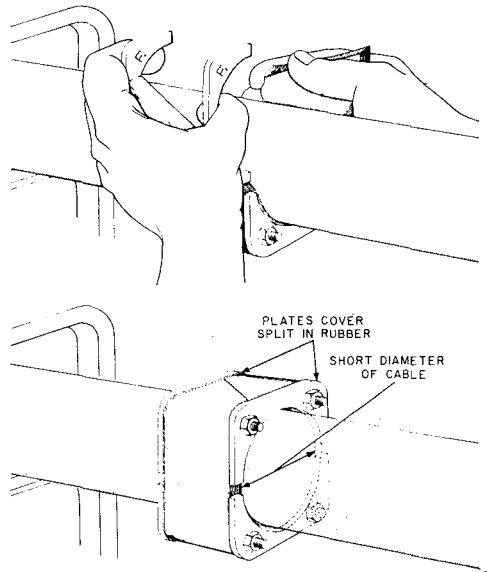

Fig. 4—Placing Split Rubber Conduit Plug on Cable

metal washers. The plug should be placed far enough into the duct to be flush with the inner edge of the bevel of the conduit or to clear any breaks extending into the bore.

Note: Plugs equipped with elongated bolts should be inserted into the duct only far enough to make the seal and yet leave the nuts outside the face of the duct when the plug is fully compressed.

5.06 Tighten the nuts with the split conduit plug wrench (Fig. 5), turning down each nut a little at a time so as to keep the pressure as uniform as possible on all sides. Too much tightening of one nut may displace the cable to one side and make access to the remaining nuts difficult. When all the nuts are equally firm, make the final tightening using the maximum effort of **one hand only** on the wrench. This produces approximately 4 foot/pounds torque which is usually adequate for making an effective seal.

5.07 When all nuts are tight and the rubber evenly compressed, there will be only a slight

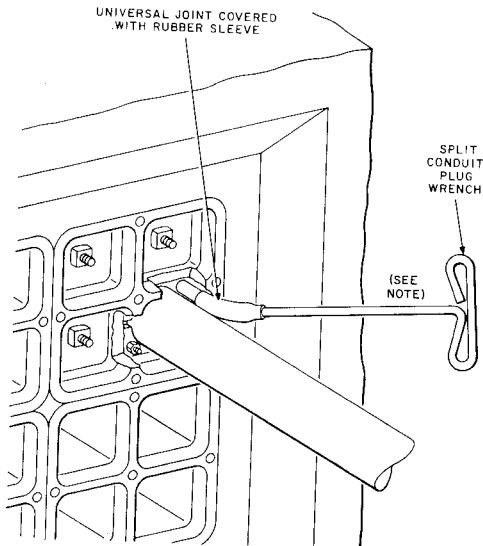

NOTE:
USE ONLY ONE HAND ON WRENCH FOR FINAL TIGHTENING.

Fig. 5—Tightening Plug With Plug Wrench

bulging of the rubber around the edges of the compression plates. If the plug is found leaking after it has been in place a few days, the condition can usually be corrected by drawing up slightly on the bolts. If this does not stop the leak, remove the plug and examine the cable and duct for irregularities that may be overcome by changing the position of the plug. Failing in this, seal around the cable with Waterplug, or B duct sealer as described in Section 628-220-204.

6. REMOVAL

SOLID RUBBER PLUGS

6.01 To extract the solid plug, first back off the nut a few threads to relieve the compression

in the rubber. The plug can then usually be withdrawn. If relieving the pressure does not restore the rubber to its original size or if it adheres to the walls of the duct, it will be necessary to apply force to the plug to work it loose. This can be done either by unscrewing the nut until about half the threads in the nut are exposed and screwing another bolt into the exposed threads to act as a handle or by twisting a piece of steel construction wire under the nut to which a prying lever can be attached.

SPLIT RUBBER PLUGS

6.02 To remove split rubber conduit plugs, first remove the nuts and outside plates from the plug, then push the bolts all the way back through the holes in the rubber to free the back plates from the rubber.

6.03 Plugs which have been in place for only a short time can sometimes be removed by using long-nose pliers to grip the rubber through one of the holes near the cut. Grip the plug at the hole in the free end of the rubber and attempt to pull out the rubber by "peeling" it from around the cable. If this is not successful, it will be necessary to use the split conduit plug remover.

6.04 The split conduit plug remover consists of three parts—sleeve, extractor, and wrench, as illustrated in Fig. 6.

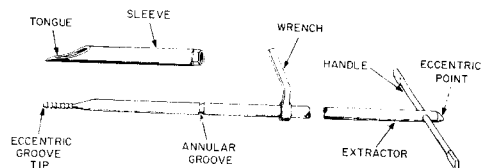

Fig. 6—Split Conduit Plug Remover

6.05 The following explains the use of the extractor in removing square split plugs. With minor variations, round split plugs are removed in the same manner.

- (1) Insert the tongue of the sleeve between the rubber and the duct wall at the hole in the free end of the rubber near the cut as it appears in the face of the plug. See Fig. 7.

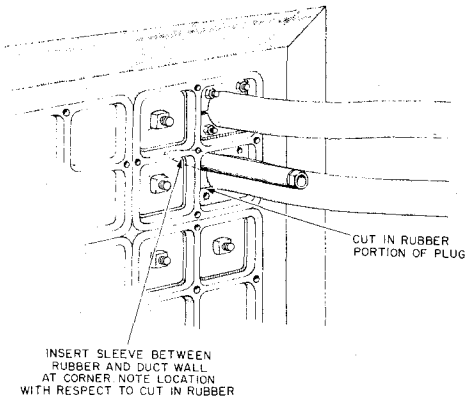

Fig. 7—Inserting Remover Sleeve

- (2) Push the tongue of the sleeve to its full depth between the rubber and the duct wall. It may be found convenient to insert the handle end of the extractor into the sleeve to provide an extension which permits a firmer grip.
- (3) Assemble the wrench on the extractor and pass the extractor through the sleeve, as illustrated. There is an eccentric point on the handle end of the extractor which is in line with the grooved tip. Turn this point toward the center of the duct and away from the wall of the conduit. This will place the tip approximately in line with the bolt hole in the rubber.
- (4) Press the extractor forward until the tip is completely embedded in the rubber. This position is reached when the annular groove in the extractor shaft is even with the end of the sleeve (Fig. 8).

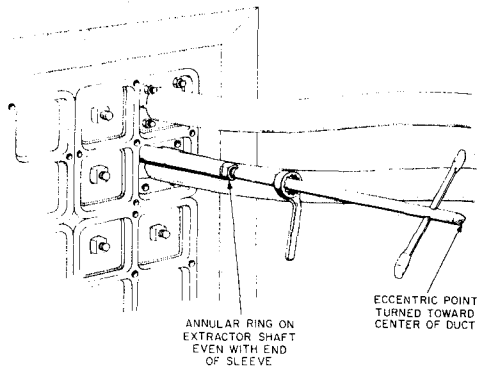

Fig. 8—Inserting Extractor

- (5) Engage the wrench with the hexagonal end of the sleeve. By means of the wrench, hold the sleeve to prevent it from turning while rotating the extractor just one-half turn. This causes the tip of the extractor to grip the rubber between it and the tongue of the sleeve. The eccentric point on the handle end will be toward the corner of the duct when the grip is fully tightened. Figure 9 shows the extractor being tightened in the rubber prior to removal.

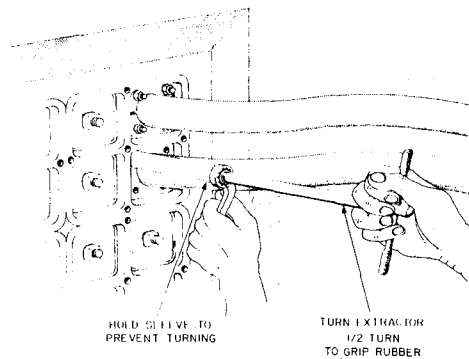

Fig. 9—Engaging Rubber with Extractor

(6) Slide the wrench back against the handle of the extractor. Gripping both the wrench and the extractor, pull gently on the extractor while shaking the cable slightly until the plug separates at the cut and starts to come out. As pulling is continued, the rubber will stretch and unwrap from the cable (Fig. 10).

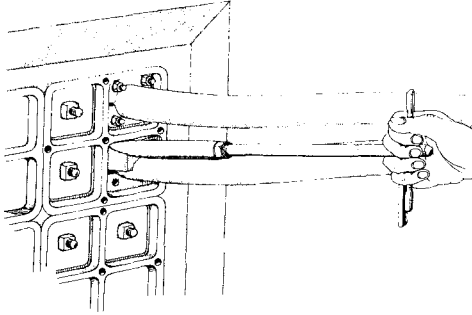

Fig. 10—Removing Split Rubber Plug

(7) If the rubber adheres to the duct or cable and makes removal difficult, release the grip on the rubber, disassemble the tool and reinsert the tongue of the sleeve by itself in a number of places around the duct to break whatever bond exists. Then reassemble the tool in the plug and resume pulling.

(8) As the rubber emerges from the duct, move the tool around the cable while pulling on the rubber so the tool will be slightly ahead of the point where the rubber is emerging.

(9) After the rubber is out, remove from the duct all of the bolts and the two back plates of the plug and reassemble the plug.

6.06 Plugs in use over long periods, in dry locations, may adhere so firmly to the conduit that they cannot be removed in a condition suitable for reuse. In removing such plugs, care should be exercised not to damage the cable sheath. Any plug considered for reuse should be examined for damage and signs of aging. If the rubber is checked, cracked, or split, do not reuse the plug.