

10-TYPE AND 12B1 CABLE STUBS

DESCRIPTION AND INSTALLATION

	CONTENTS	PAGE
1.	GENERAL	1
2.	PRECAUTIONS	1
3.	DESCRIPTION	1
4.	INSTALLATION	3

1. GENERAL

1.01 This practice covers the description and installation of 10-type and 12B1 cable stubs. The stubs can be joined to paper, pulp, or plastic insulated conductor cables. They are used between two pressurized cables or between a pressurized and nonpressurized cable to keep the cables separated pneumatically.

1.02 This practice is reissued to add the 10D, 10E1, and 12E1 cable stubs and delete reference to the 10C1 cable stub that has been rated Mfr Disc. Revision arrows are used to emphasize these changes.

2. PRECAUTIONS

2.01 Do not bend the stub within 6 inches of the plug.

2.02 Do not place the cable stub under tension.

2.03 When anchoring the cable stub to a pole with cable clamps, place the clamps at least 12 inches from the plug.

3. DESCRIPTION

3.01 *The 10A1 cable stub* contains an air plug and is fully color-coded 24-gauge PIC cable with an ALPETH sheath.

3.02 *The 10B1 cable stub* contains an air plug and is fully color-coded 24- and 26-gauge PIC cable with a PASP sheath. The 10B1 cable stub is intended for use in areas where protection against gophers or lightning is required.

3.03 *The 10D cable stub* has PASP sheath with the short stub being air core and the long stub filled with D encapsulant. Stubs 900 pair and below have 24-gauge conductors while stubs above 900 pair have 26-gauge conductors. The 10D cable stub is intended as an interface between filled cable and air-core cable.

3.04 *The 12B1 cable stub* contains an air plug and is a noncolor-coded PIC cable with a PASP sheath. The 12B1 cable stub is intended for use with the RICS (Reenterable in Cable Splice) Systems.

3.05 A 10A1 cable stub is illustrated in Fig. 1. The 10B1, 10D, 10E1, 12B1, and 12E1 cable stubs are similar in outward appearance to the 10A1 cable stub. Stub cable combinations are shown in Table A.

3.06 For the 10A1, 10B1, 10D, and 10E1, a factory-installed air plug is located 10 feet from one end of the cable stub. The plug is made with plugging compound and a polyethylene tube. It varies in diameter from 1.13 inches od for the 50-pair stub to 4.25 inches od for the 900-pair stub. The lengths of the plugs vary from 9 inches for the 50-pair stub to 18 inches for the 900-pair 10B1 cable stub. The code and size designation is stamped on the air plug.

3.07 The 12B1 and the 12E1 cable stubs have a factory-installed air plug 10 feet from one end. The plug is made with plugging compound and a polyethylene tube. The plug varies in diameter from 2.12 inches od for the 600-pair stub to 2.74 inches od for the 1800-pair stub. The plug length is 18 inches for all sizes of the cable stub. The code and size designation is stamped on the air plug.

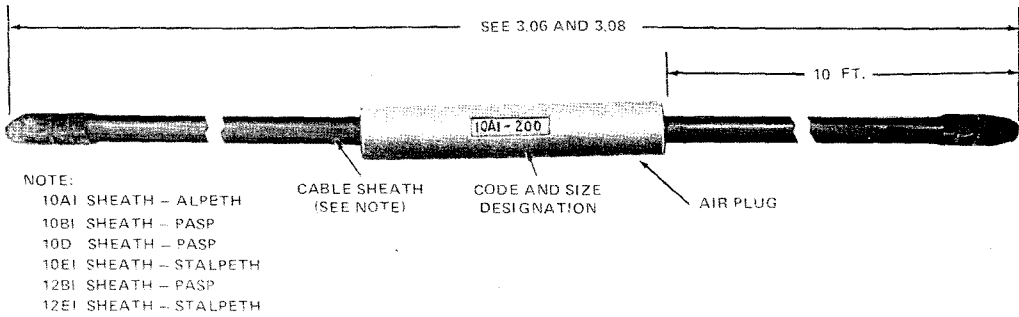

Fig. 1—101A Cable Stub

→TABLE A←

STUB CABLE COMBINATIONS

STUB CABLE	PAIR SIZES	STANDARD LENGTHS (FEET)	OPTIONAL LENGTHS (FEET)
10A1	50, 100, 200, 300, 400 600, 900, (24 gauge)	20, 30, 40, 50 30	60 to 100 in increments of 10 ft 20 to 50 in increments of 10 ft
10B1	50, 100, 200, 300, 400 600, 900 (24 gauge) 1200, 1500, 1800 (26 gauge)	20, 30, 40, 50 30 30	60 to 100 in increments of 10 ft 20 to 50 in increments of 10 ft 20 to 50 in increments of 10 ft
10D	50, 100, 200, 300, 400, 600, 900 (24 gauge) 1200, 1500, 1800 (26 gauge)	20, 30 20, 30	Longer lengths on special order Longer lengths on special order
10E1	50, 100, 200, 300, 400 600, 900 (24 gauge) 1200, 1500, 1800 (26 gauge)	20, 30, 40, 50 30 30	60 to 100 in increments of 10 ft 20 to 50 in increments of 10 ft 20 to 50 in increments of 10 ft
12B1	600, 900 (24 gauge) 1200, 1500, 1800 (26 gauge)	30 30	20 to 50 in increments of 10 ft 20 to 50 in increments of 10 ft
12E1	600, 900 (24 gauge) 1200, 1500, 1800 (26 gauge)	30 30	20 to 50 in increments of 10 ft 20 to 50 in increments of 10 ft

3.08 The 12B1 and 12E1 cable stubs use the same basic cable core construction as standard air-core PIC cable except that half of the conductors are white. There are only five unique pairs: blue-white, orange-white, green-white, brown-white, and slate-white. The 600- and 900-pair sizes are made up of 50-pair multiunits containing 12 and 13 primary units. The 1200, 1500, and 1800 pairs are made up of 100-pair multiunits containing 25-pair primary units. The core diagrams are shown in Fig. 2.

3.09 Electrical continuity is provided across the air plug by a grounding harness connected between the metallic sheaths. Two to eight grounding harnesses are used for various sizes of stub cable to match the conductivity of the cable shield. ***These grounding harnesses are not intended to restore mechanical strength to the cable.***

4. INSTALLATION

4.01 The cable stub is placed the same as any other cable. The pressure plug is airtight at both ends; either end may be connected to the pressurized cable.

4.02 The 12-type stub is equipped with a factory-installed pressure plug. If an air source is not available, an air pipe bypass should be provided from the main splice to the RICS closure to provide air pressure to the RICS. This pipe must have a valve so that the pressure can be removed from the RICS for reentry, thus eliminating buffering. The 12-type stub may be used without a pressure plug, thus eliminating the air pipe; however, buffering is now required during reentry of the RICS. A 10-type stub is required to provide interface between RICS and water-proof distribution cable.

