

CABLE PRESSURE SYSTEMS REINFORCING LEAD SLEEVES

1. GENERAL

1.01 This section covers the method of reinforcing lead or lead-antimony sleeves with lashed cable supports to prevent swelling due to internal pressure. The lead, lead-antimony, and extra strength lead sleeves are replaced by B lead-calcium sleeves.

1.02 This section is revised to update the text and to conform to present standards. Since this is a general revision, arrows ordinarily used to indicate changes have been omitted.

1.03 Reinforcement *is not necessary* on the superseded extra strength lead sleeves (one identifying ridge), or on either split or nonsplit B lead-calcium sleeves. Reinforcement also is not required on cables maintained at 6 psi or less.

1.04 Reinforcement *is required* on sleeves maintained at greater than 6 psi under the following conditions:

- (a) On thin-wall sleeves, 4-1/2 inches and larger in diameter, made of lead (no ridge) or lead-antimony (three ridges)
- (b) Any other sleeve which shows evidence of swelling under continuous pressure.

2. MATERIAL

2.01 The lengths of lashed cable supports required on the sleeves which are likely to need reinforcement are listed in Table A.

TABLE A

LENGTH OF CABLE SUPPORTS USED TO
REINFORCE LEAD SLEEVES (INCHES)

SLEEVE DIAMETER	UNDERGROUND SLEEVES	AERIAL SLEEVES	
	ALL SUPPORTS— 2 TURNS	END SUPPORTS— 3 TURNS	INTERMEDIATE SUPPORTS— 2 TURNS
4½	45	66	45
5	45	66	45
5½	45	66	45
6	45	66	45
6½	66	78	66
7	66	78	66

NOTICE

Not for use or disclosure outside the
Bell System except under written agreement

2.02 The standard listing for lashed cable supports is as follows:

Support, Cable, Lashed, B (Length) Corrosion-resistant steel bands, 3/4-inch wide. From 10 to 14 are required for each sleeve.

3. METHOD OF PLACING SUPPORTS

3.01 The method of reinforcing lead sleeves is illustrated in Fig. 1.

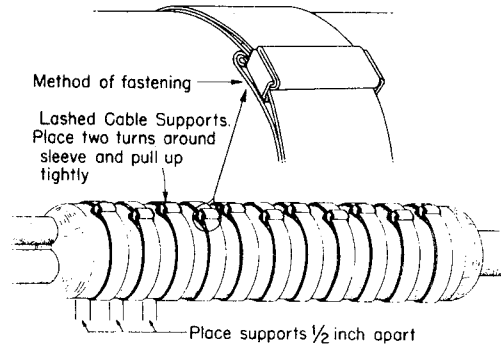

On aerial cable, place cable spacers and support sleeve from strand by applying the end supports in the usual manner. (see section 627-340-101)

Fig. 1—Placing B Lashed Cable Supports