

AERIAL LIFT TRUCKS PREPARATION FOR USE

CONTENTS	PAGE
1. GENERAL	1
2. PREPARING TO PLACE STRAND	2
3. PREPARING TO PLACE CABLE	5
4. PREPARING TO PLACE SELF-SUPPORTING CABLE	6
5. PREPARING TO USE WINCH OR TOW LINE	7

1. GENERAL

1.01 This section describes, in general, the preparation necessary prior to placing strand or cable using an aerial lift truck. The description and operation of aerial lift trucks are covered in the 649 Division of the Bell System Practices. The placing of strand and self-supporting cable using an aerial lift truck is covered in the 627 Division of the Bell System Practices.

1.02 This section does not replace information contained in the operation and maintenance manual furnished by the manufacturer with each aerial lift but supplements that information by describing the use of the major components of aerial lift equipment when preparing for placing operations.

1.03 Different makes of aerial lift trucks may utilize different methods for positioning the work basket, have different types of controls, or vary as to the location of controls, guides, sheaves, etc, which are a part of the equipment, but the loading and transporting of reels and the use of the equipment when placing strand or cable is basically the same for all makes.

1.04 As a part of aerial lift truck equipment, the spindles for use in strand or cable placing operations are equipped with cable reel brakes. The cable reel brakes may be manually, hydraulically,

or electrically controlled. The manually controlled brakes are shown in Fig. 1. The electrically controlled brakes and the controls in the truck cab are shown in Fig. 2 and Fig. 3.

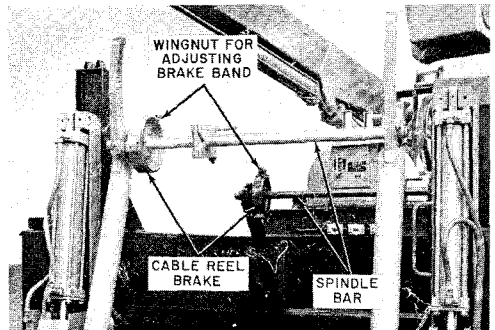

Fig. 1—Manually Controlled Cable Reel Brakes

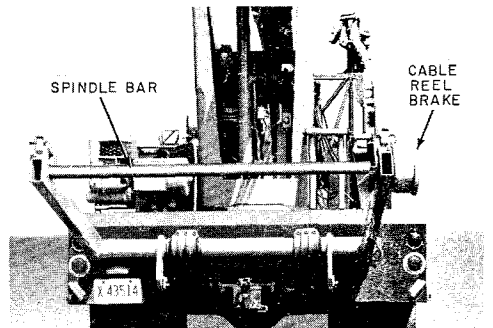

Fig. 2—Electrically Controlled Cable Reel Brake

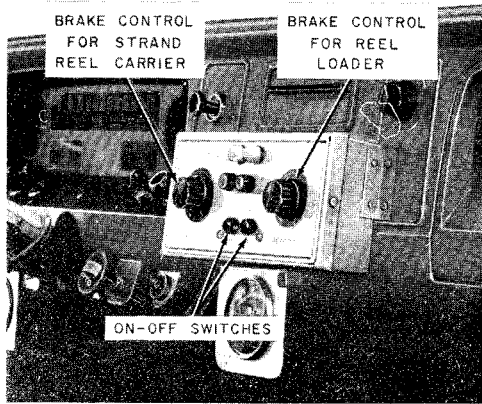

Fig. 3—Controls for Electric Cable Reel Brake

1.05 Before using an aerial lift truck for the operations covered in this section, review the appropriate section in the 649 Division of the Bell System Practices covering the operation of the aerial lift. All safety precautions given in the applicable section are to be observed as well as those in the 620 Division that pertain to guarding work areas and to placing cable or strand. Pay particular attention to the boom strength limitations outlined in Section 627-700-201.

2. PREPARING TO PLACE STRAND

2.01 *Using the reel carrier on the SERVI-LIFT:*

Strand may be placed with the strand reel mounted in the reel carrier. When preparing to use the reel carrier:

- (1) Position the strand reel at the rear of the truck so the strand will pay out forward off the top of the reel when the reel is in the reel carrier.
- (2) With the reel clamp positioned on the shaft, fit the 2-inch spindle (with brake) into the center hole of the reel so the brake will be on the left side of the reel when the reel is in position on the reel loader. An extra hole may have to be drilled in the reel to accept the pin on the reel clamp.

- (3) Place a centering cone on the shaft to hold the reel firmly against the reel clamp and tighten the setscrew to hold reel in place.

- (4) Lower the reel loader and position the reel so the ends of the spindle are above and in line with the supports on the ends of the loader arms.

- (5) Raise the loader slowly until the spindle is cradled in the supports. Lock the spindle in place.

- (6) Raise the loader until the reel rests on the truck bed. Align the reel carrier with the spindle, release the spindle from the reel loader, and transfer the reel to the reel carrier. Lock the spindle in place on the reel carrier and raise the carrier to place the reel in the pay-out position.

- (7) On the SERVI-LIFT Model T-29-MC, thread the strand forward from the reel, through the roller guide at the base of the turret, upward through the two guide sheaves on the mast, and then through the roller guide on the basket. (See Fig. 4.) On the SERVI-LIFT Model S-31-MT, thread the strand forward from the reel, through the roller guides on the turret, through the roller guide at the bottom of the bull wheel, around the bull wheel, through the roller guide at the top of the bull wheel, and through the roller guide on the basket. (See Fig. 5.)

2.02 *Using the reel carrier on the TELSTA:*

Strand may be placed with the strand reel mounted in the strand reel carrier. When preparing to use the strand reel carrier:

- (1) Place the strand reel on the curb side of the truck close to the rear wheel. Place the reel so the strand will feed forward off the bottom of the reel when the reel is in place on the strand reel carrier.
- (2) Raise the boom and rotate it to position the boom yoke directly over the strand reel.
- (3) Remove the spindle assembly from the strand reel carrier and fit the spindle into the center hole of the strand reel making sure the brake is on the proper side. Push the spindle through until the drive pin on the drive plate seats in the offset hole in the strand reel.

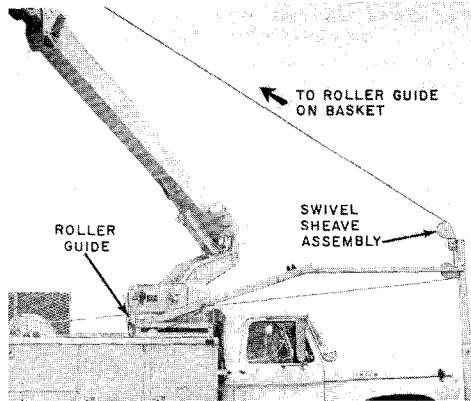

Fig. 4—Using Strand Reel Carrier on SERVI-LIFT Mode T-29-MC for Strand Placing Operations

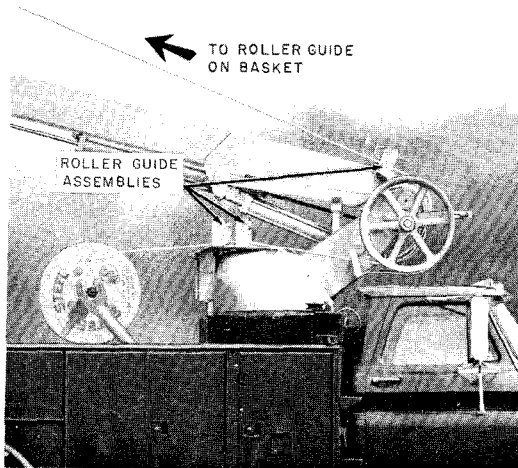

Fig. 5—Using Strand Reel Carrier on SERVI-LIFT Model S-31-MT for Strand Placing Operations

- (4) Place the reel adapter collar on the end of the spindle with the tapered end in contact with the reel. Tighten the setscrew.
- (5) Attach the TELSTA lifting chain as shown in Fig. 6 (or other chain of suitable length

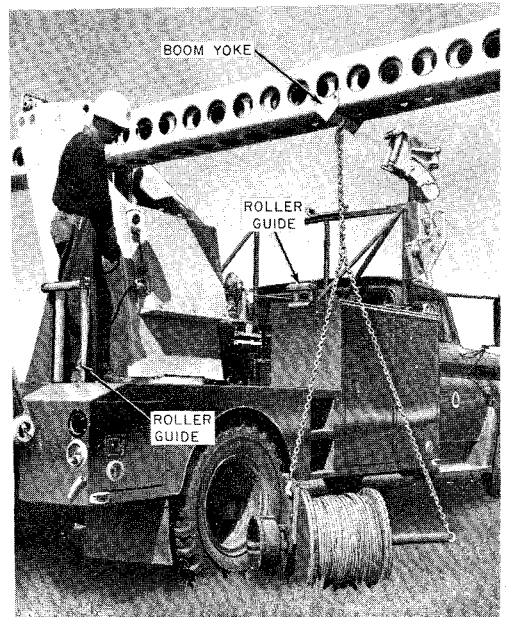

Fig. 6—Method of Attaching Lifting Chain on TELSTA

to allow reel, when lifted, to clear truck body) to the hook on the boom lifting yoke. Attach the chain to the reel so the reel will not tilt when lifted.

- (6) Elevate the boom until the reel is clear of the truck body and rotate the boom to position the reel over the strand reel well.
- (7) Lower the boom to lower the reel into the strand reel well. While the reel is being lowered, it must be guided so the spindle will seat properly on the spindle support frames. Close the latches on the support frame and detach the lifting chain. Fig. 7 shows the reel in place.
- (8) Remove the pin from the top section of the swivel bull wheel, swing the section forward, and lock in place by replacing the pin.

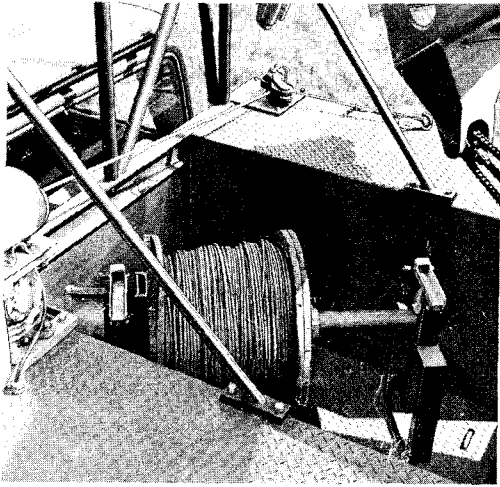

Fig. 7—Reel in Place in TELSTA Strand Reel Carrier

(9) Thread the strand up through the strand sheave located to the left of the swivel bull wheel (Fig. 8) and through the roller guide (fairlead) at the basket.

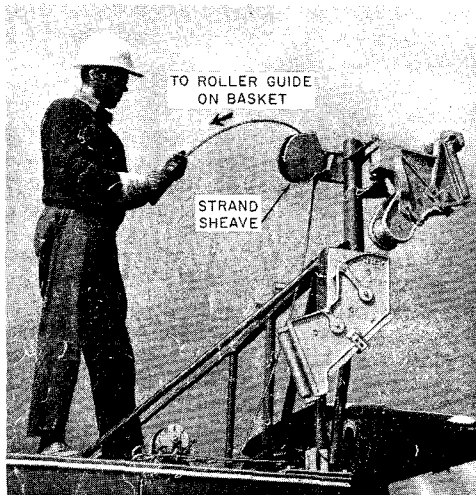

Fig. 8—Strand Threaded Through Strand Sleeve on TELSTA

2.03 Using the rear-mounted reel carrier on the SKYWORKER (Models not equipped with hydraulically operated reel loader): Strand may be placed with the reel mounted on the reel carrier. When preparing to place strand:

- (1) Position the reel at the rear of the truck so the strand will feed forward off the top of the reel when the reel is in place on the reel carrier.
- (2) Raise the upper boom enough to allow the basket to clear the truck body and position the lifting yoke on the lower boom over the reel.
- (3) Remove the spindle assembly from the reel carrier and fit the spindle into the center hole of the strand reel. Secure the reel on the spindle with a centering collar and a drive plate.
- (4) Attach the lifting chain to the boom lifting yoke. Attach the chain to the reel so the reel will not tilt when lifted.
- (5) Elevate the boom to lift the reel. The reel must be guided (Fig. 9) so the spindle bar will seat properly on the spindle support arms. Secure the spindle on the arms and detach the lifting chain from the reel and boom.
- (6) Thread the strand through the guides and around the bull wheel (Fig. 10) and to the roller guide at the basket.

USING THE HYDRAULICALLY OPERATED REEL LOADER WHEN PLACING STRAND

2.04 To use the reel loader when placing strand, mount the strand reel using the following procedure:

- (1) Position the reel at the rear of the truck so the strand will feed forward off the top of the reel on the SERVI-LIFT or SKYWORKER and off the bottom of the reel on the TELSTA.
- (2) Lower the loader and remove the spindle. Fit the spindle into the center hole of the reel so the reel is approximately centered on the spindle. Place the centering collar on the spindle.
- (3) Move the reel forward to position the spindle and brake above and in line with the supports on the loader arms. Raise the loader until the

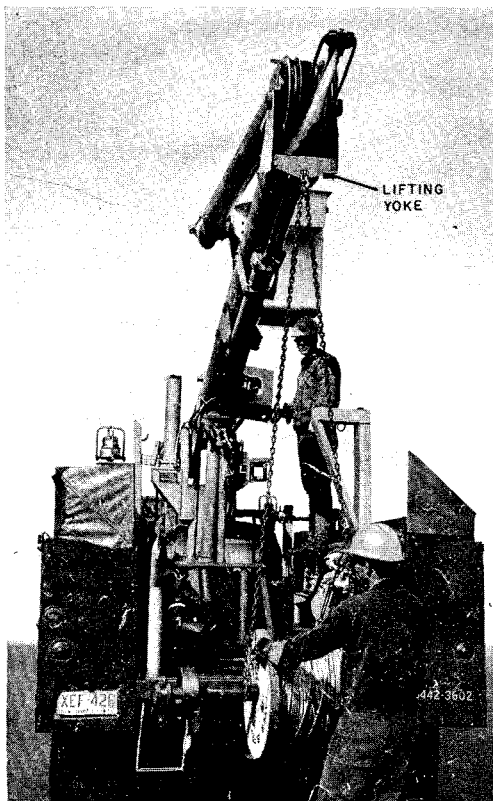

Fig. 9—Method of Attaching Lifting Chain on SKYWORKER

spindle is supported by the loader arms. Lock the spindle bar in place.

(4) Raise the loader just enough to allow the reel to clear the ground. Engage the drive plate or reel clamp, and slide the centering collar against the reel and tighten the setscrew.

(5) Raise the loader to place the reel in the pay-out position.

2.05 With the strand reel raised to the pay-out position, thread the strand forward through the guides on the SERVI-LIFT in the manner shown in Fig. 4 and 5. For the TELSTA, thread

the strand through the guides mounted at the right rear and at the right center of the truck body (Fig. 6) and then through the strand sheave shown in Fig. 8. For the SKYWORKER, pass the strand from the reel, through the guides and around the main guide sheave as shown in Fig. 10.

3. PREPARING TO PLACE CABLE

3.01 Cable reels may be transported to the work location on the reel loader or reel carrier, or by some other suitable means, such as on a cable reel trailer. If possible the reel should be properly mounted on the reel loader prior to the placing operation. However, since the capacity of reel loaders is limited with respect to reel weight and size, it may be necessary to use the cable reel trailer if the reel is too large or too heavy for the loader. The threading of cable from the cable reel trailer is the same as from the reel loader.

3.02 To mount the reel:

(1) Position the reel at the rear of the truck so the cable will feed forward off the bottom of the reel on the TELSTA or forward off the top of the reel on the SERVI-LIFT or SKYWORKER.

(2) Lower the loader and remove the spindle. Fit the spindle into the center holes of the reel spokes (Fig. 11), making sure the brake is on the proper side, and approximately center the spindle in the reel. Place a centering cone on the spindle shaft but do not tighten at this time.

(3) Move the reel forward to position the spindle and brake above and in line with the supports on the loader arms. Raise the loader until the spindle is supported by the loader arms and lock the spindle in place.

(4) Raise the loader just enough to allow the reel to clear the ground and slide the reel toward the spindle brake to engage the driveplate or reel clamp. Slide the centering collar against the reel and tighten the setscrew.

(5) Raise the loader to place the reel in its pay-out position.

(6) On the TELSTA, thread the cable through the guides to the main guide sheave or swivel

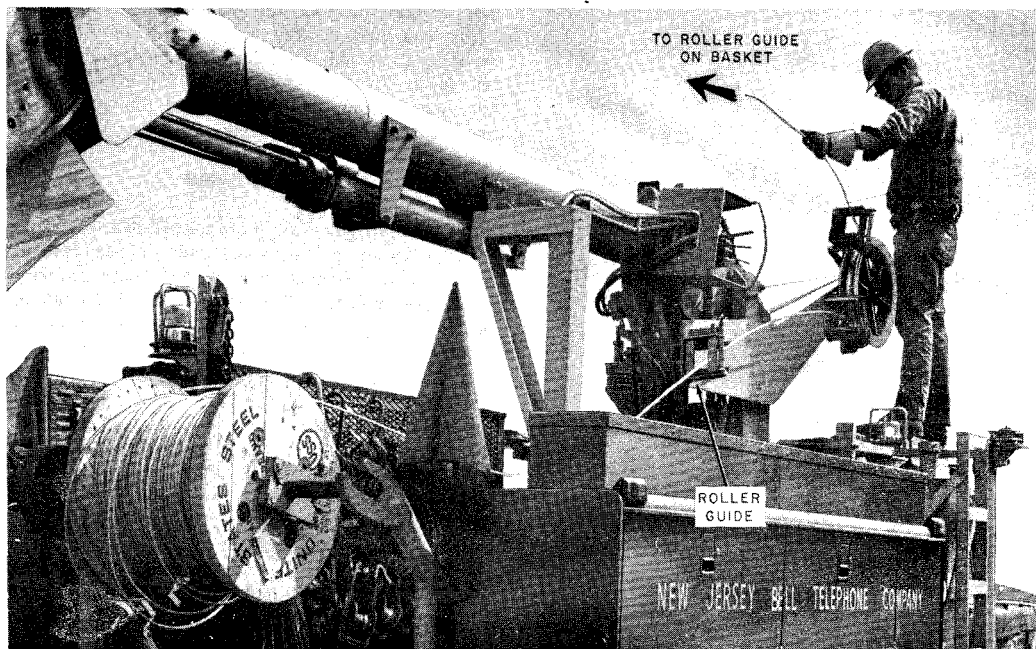

Fig. 10—Strand Threaded Through Guides on SKYWORKER

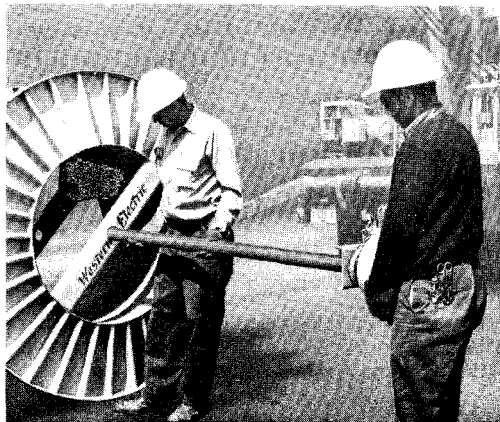

Fig. 11—Fitting the Spindle Into the Cable Reel Spokes

bull wheel as shown in Fig. 12 and 13. Be sure to remove the locking pin to permit the sheave to swivel freely. Pass the cable from the main guide sheave directly to the point of attachment aloft. **Do not pass cable through the roller guide at the work basket.** The SERVI-LIFT model with folding booms and the SKYWORKER have a roller guide mounted above the main guide sheave. Pass the cable through this guide in the same manner used for strand (see Fig. 5 and 10), but do not use the guide at the work basket. The SERVI-LIFT with the telescoping boom is equipped with a forward mounted guide chute assembly (Fig. 14). The cable passes through the assembly and directly to the point of attachment.

4. PREPARING TO PLACE SELF-SUPPORTING CABLE

4.01 Mount the reel of self-supporting cable on the reel loader using the method covered in 3.01 for regular cable. Self-supporting cable is

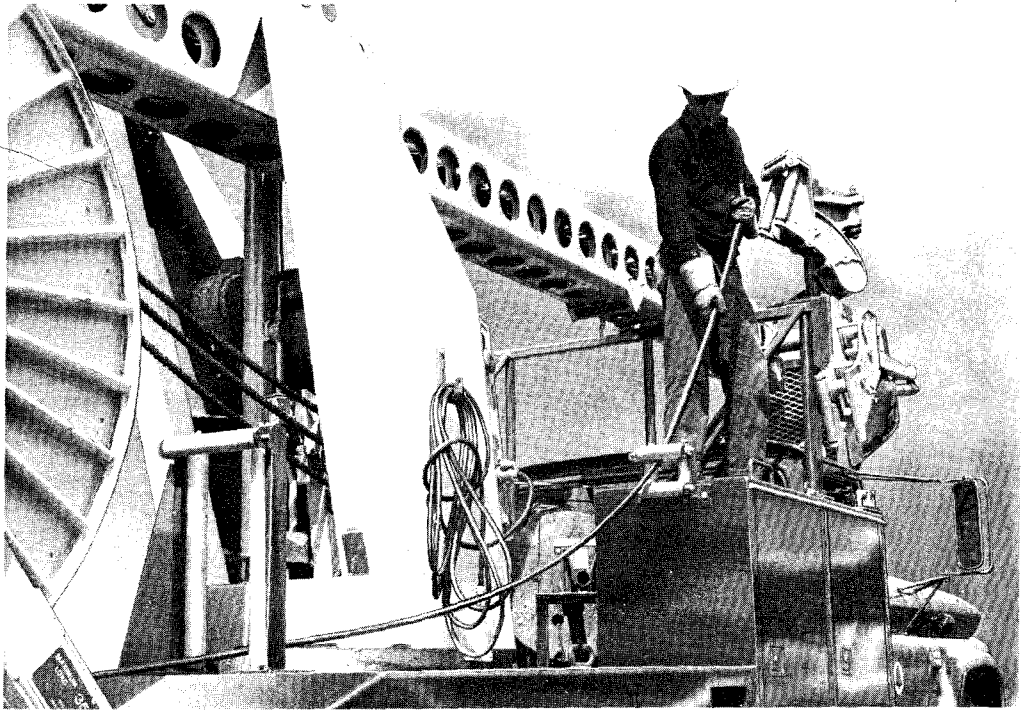

Fig. 12—Threading Cable Through Guides on TELSTA

threaded through the guides the same as other cable except that the self-supporting cable is threaded through the roller guide at the work basket where regular cable is not.

4.02 Since it is necessary to use the roller guide at the work basket when placing self-supporting cable, special consideration must be given to additional stresses that will be imposed on the boom during this type of work operation. Refer to Section 627-700-201 for load limits and precautions that apply to placing self-supporting cable with an aerial lift truck when using the moving reel method.

5. PREPARING TO USE WINCH OR TOWLINE

5.01 The towlines or winch lines on each of the aerial lift trucks, in general, have different physical locations on the truck, have different

capabilities, and utilize one or more guide sheaves for guiding the line to the work location aloft.

5.02 The TELSTA aerial lift is equipped with an electric towline which is mounted on the left forward part of the truck body. The nonmetallic line passes through one guide sheave from the towline drum to the work location. The guide sheave is mounted with a removable retaining pin that allows the sheave to be transferred from one side of the truck to the other allowing the line to be used off either side of the truck.

5.03 The SERVI-LIFT model aerial lift with the *folding boom* is equipped with a winch mounted forward in the truck bed. The 3/8-inch wire rope can be threaded through guide sheaves mounted forward on either side of the truck body.

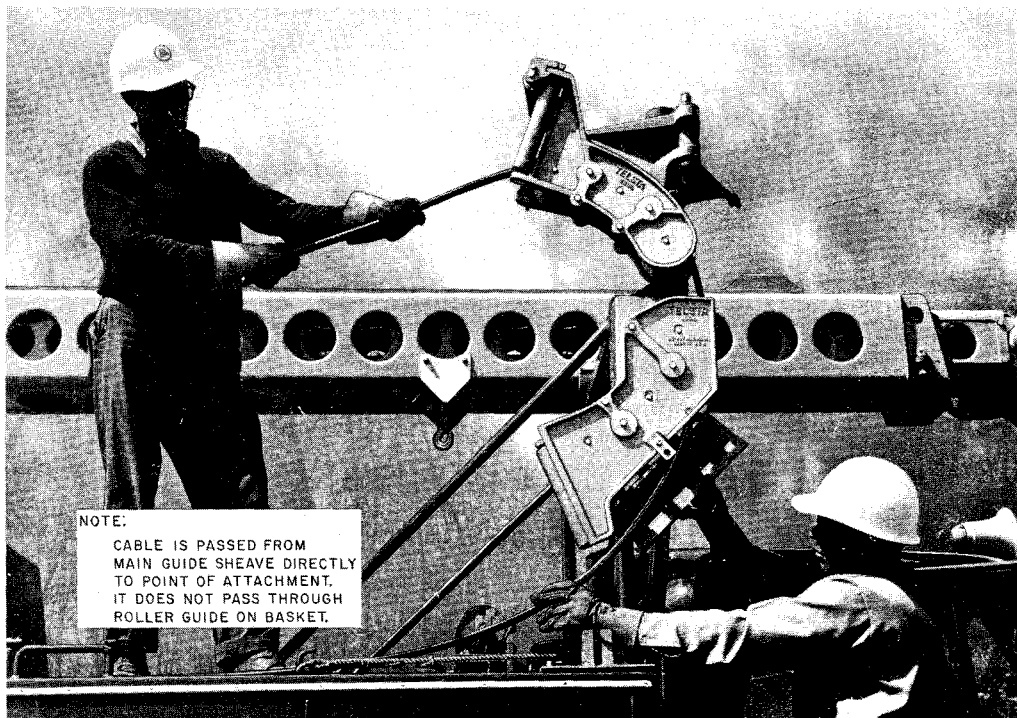

NOTE:

CABLE IS PASSED FROM MAIN GUIDE SHEAVE DIRECTLY TO POINT OF ATTACHMENT. IT DOES NOT PASS THROUGH ROLLER GUIDE ON BASKET.

Fig. 13—Threading Cable Through Main Guide Sheave on TELSTA

The winch may also be used for conventional pull off the rear of the truck.

5.04 The SERVI-LIFT model with the *telescopic boom* is equipped with a powered towline. The towline drum is located inside the right-hand front compartment of the truck body. The nonmetallic line passes through the top of the compartment over a roller guide, forward to a block mounted at the main guide sheave, and then up to the work location aloft.

5.05 The SKYWORKER aerial lift is equipped with a winch mounted in the truck bed. The 3/8-inch wire rope is led down through the body deck, forward through a series of blocks and flexible steel tubing fixed to the underside of the truck chassis, and up a telescopic boom mounted

at the front of the truck on a chassis frame extension. The boom may be locked in either a right or left pedestal to allow the line to be used off either side of the truck.

5.06 To assist in threading heavy cable, the winch line or towline may be used. With the cable reel mounted on the reel loader, move the truck to the work location and, using the work basket, attach a snatch block to the pole or strand. Thread the towline or winch line through its snatch block on the truck and then up through the snatch block on the pole or strand. From this point, thread the line through roller guide at the basket and down through the main guide sheave and roller guides to the end of the cable at the reel. Attach the line to the cable and take up on the winch line or towline to pull the cable through the guides

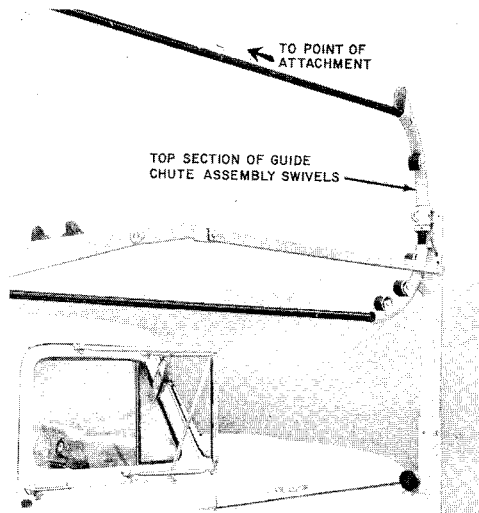

Fig. 14—Cable Threaded Through Guide Chute Assembly on SERVI-LIFT

and to the pole. Fig. 15 illustrates the use of the TELSTA towline for threading heavy cable. The method used with other aerial lifts is similar in that the towline or winch line is threaded from the point of attachment on the pole or strand, through the various guides, and to the end of the cable at the reel. Remove the cable from the roller guide at the basket before starting the cable placing operation.

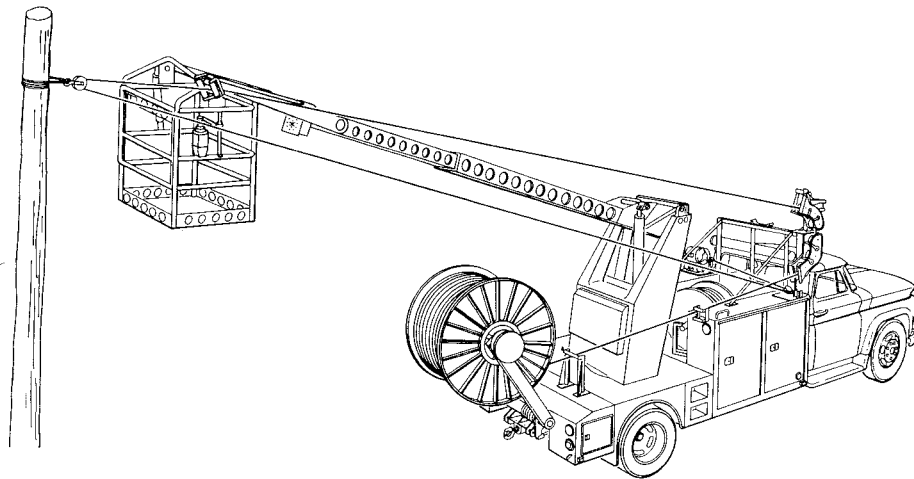

Fig. 15—Using The Tow Line for Threading Heavy Cable