



NORTEL

Nortel Secure Router 4134

Quick Start

Release: 10.1

Document Revision: 02.01

www.nortel.com

NN47263-100

323245-B

Nortel Secure Router 4134
Release: 10.1
Publication: NN47263-100
Document status: Standard
Document release date: 18 February 2008

Copyright © 2007, 2008 Nortel Networks
All Rights Reserved.

The information in this document is subject to change without notice. The statements, configurations, technical data, and recommendations in this document are believed to be accurate and reliable, but are presented without express or implied warranty. Users must take full responsibility for their applications of any products specified in this document.

This document is protected by copyright laws and international treaties. All information, copyrights and any other intellectual property rights contained in this document are the property of Nortel Networks. Except as expressly authorized in writing by Nortel Networks, the holder is granted no rights to use the information contained herein and this document shall not be published, copied, produced or reproduced, modified, translated, compiled, distributed, displayed or transmitted, in whole or part, in any form or media.

Sourced in Canada, the United States of America, and India.

*Nortel, the Nortel logo, and the Globemark are trademarks of Nortel Networks.

All other trademarks are the property of their respective owners.

ATTENTION: Before unpacking, installing, or using the Secure Router 4134, ensure you read the section about regulatory information and general safety precautions in the first chapter of this guide.

Contents

Secure Router 4134 regulatory information and safety precautions	7
International Regulatory Statements of Conformity	7
National Electromagnetic Compliance (EMC) Statements of Compliance	7
FCC statement (USA only)	7
TIA-968-A	8
ICES statement (Canada only)	8
CE marking statement (Europe only)	8
European Union and European Free Trade Association (EFTA) notice	9
VCCI statement (Japan/Nippon only)	10
BSMI statement (Taiwan only)	10
MIC notice (Republic of Korea only)	10
National Safety Statements of Compliance	11
EN 60950 statement	11
NOM statement (Mexico only)	11
Información NOM (unicamente para México)	11
Denan statement (Japan/Nippon only)	12
National Environmental Statements of Compliance	12
RoHS Directive Compliance Statement	12
WEEE Directive Compliance Statement	13
Safety messages	13
Notices	13
Cautions and warnings for the Secure Router 4134	15
Foreign Exchange Station (FXS) Interface Modules	17
Foreign Exchange Office (FXO) Interface Modules	18
Personal safety and equipment protection	18
Module protection	18
Cables and connectors protection	19
Electrostatic discharge	19
Antistatic material	20
New in this release	21
Features	21
Interface modules	21

Introduction	23
Navigation	23
Secure Router 4134 installation and initial configuration	25
Secure Router 4134 installation and initial configuration tasks	25
Secure Router 4134 installation and initial configuration navigation	27
Installing the Secure Router 4134 chassis and hardware components	29
Unpacking and inspecting the Secure Router 4134 chassis	29
Installing a power supply module	30
Prerequisites	31
Installing the mounting brackets on the chassis	31
Prerequisites	33
Installing the chassis	34
Prerequisites	35
Grounding the chassis	36
Prerequisites	37
Installing the interface modules	39
Prerequisites	41
Installing a Small Module	41
Installing a Medium Module	42
Installing a Large Module	42
Installing a Small Module in the Voice Carrier Medium Module	43
Connecting power cables	46
Connecting AC power cables	46
Connecting DC power	47
Powering up the router	52
Prerequisites	52
Verifying a successful installation	52
Configuring the Secure Router 4134 for remote access	55
Connecting a terminal for local access	55
Prerequisites	56
Establishing remote access	56
Using SSH for remote access	57
Changing the default administrator password	58
Environmental requirements	61
Translations of safety messages	63
Class A device caution statement	63
Qualified service personnel warning statement	64
Overcurrent warning statement	65
Cover plate warning statement	66

Power cord warning statement 67

Secure Router 4134 regulatory information and safety precautions

International Regulatory Statements of Conformity

This is to certify that the Nortel Secure Router 4134 equipment was evaluated to the international regulatory standards for electromagnetic compliance (EMC) and safety and were found to have met the requirements for the following international standards:

- EMC – Electromagnetic Emissions – CISPR 22, Class A
- EMC – Electromagnetic Immunity – CISPR 24
- Electrical Safety – IEC 60950, with CB member national deviations

Further, the equipment has been certified as compliant with the national standards as detailed below.

National Electromagnetic Compliance (EMC) Statements of Compliance

FCC statement (USA only)

This equipment has been tested and found to comply with the limits for a Class A digital device, pursuant to Part 15 of the Federal Communications Commission (FCC) rules. These limits are designed to provide reasonable protection against harmful interference when the equipment is operated in a commercial environment. This equipment generates, uses, and can radiate radio frequency energy. If it is not installed and used in accordance with the instruction manual, it may cause harmful interference to radio communications. Operation of this equipment in a residential area is likely to cause harmful interference, in which case users will be required to take whatever measures may be necessary to correct the interference at their own expense. Changes or modifications not expressly approved by Nortel could void the user's authority to operate the equipment.

TIA-968-A

This equipment complies with Part 68 of the FCC rules. The FCC Part 68 label is located on the bottom chassis panel. This label contains the FCC Registration Number and Ringer Equivalence Number (REN) for this equipment. If requested, this information must be provided to your telephone company.

Connection to the telephone network should be made by using standard modular telephone jacks, type RJ-48C. The RJ-48C plug and/or jacks used must comply with the FCC Part 68 rules.

MFRs Port Identifier	Facilities Interface Code	Service Order Code	Network Connectors
T1: lines 1–16	04DU9-1SN 04DU9-1ZN	6.0N	RJ-48C

ICES statement (Canada only)

Canadian Department of Communications Radio Interference Regulations

This digital apparatus (Nortel Secure Router 4134) does not exceed the Class A limits for radio-noise emissions from digital apparatus as set out in the Radio Interference Regulations of the Canadian Department of Communications.

Règlement sur le brouillage radioélectrique du ministère des Communications

Cet appareil numérique (le commutateur Nortel Secure Router 4134) respecte les limites de bruits radioélectriques visant les appareils numériques de classe A prescrites dans le Règlement sur le brouillage radioélectrique du ministère des Communications du Canada.

CE marking statement (Europe only)

EN 55022 statements

This is to certify that the Nortel Secure Router 4134 equipment is shielded against the generation of radio interference in accordance with the application of Council Directive 2004/108/EC. Conformity is declared by the application of EN 55022 Class A (CISPR 22).

**CAUTION**

This device is a Class A product. In a domestic environment, this device can cause radio interference, in which case the user may be required to take appropriate measures. For translations of this message, see [“Translations of safety messages” \(page 63\)](#).

**CAUTION
ACHTUNG**

Dies ist ein Gerät der Klasse A. Bei Einsatz des Geräts in Wohngebieten kann es Störungen des Radio- und Fernsehempfangs verursachen. In diesem Fall muss der Benutzer alle notwendigen Maßnahmen ergreifen, die möglicherweise nötig sind, um die Störungen auf eigene Rechnung zu beheben.

EN 55024 statement

This is to certify that the Nortel Secure Router 4134 is shielded against the susceptibility to radio interference in accordance with the application of Council Directive 2004/108/EC. Conformity is declared by the application of EN 55024 (CISPR 24).

EN 300386 statement

The Nortel Secure Router 4134 complies with the requirements of EN 300386 V1.3.3 for emissions and for immunity for a Class A device intended for use in either Telecommunications centre or locations other than telecommunications centres given the performance criteria as specified by the manufacturer.

European Union and European Free Trade Association (EFTA) notice

All products labeled with the CE marking comply with R & TTE Directive (1999/5/EEC) which includes the Electromagnetic Compliance (EMC) Directive (2004/108/EC) and the Low Voltage Directive (2006/95/EC) issued by the Commission of the European Community.

Compliance with these directives implies conformity to the following European Norms (ENs). The equivalent international standards are listed in parenthesis.

- EN 55022 (CISPR 22)–Electromagnetic Interference
- EN 55024 (IEC 61000-4-2, -3, -4, -5, -6, -8, -11)–Electromagnetic Immunity

- EN 61000-3-2 (IEC 610000-3-2)–Power Line Harmonics
- EN 61000-3-3 (IEC 610000-3-3)–Power Line Flicker

VCCI statement (Japan/Nippon only)

This is a Class A product based on the standard of the Voluntary Control Council for Interference (VCCI) for information technology equipment. If this equipment is used in a domestic environment, radio disturbance may arise. When such trouble occurs, the user may be required to take corrective actions.

この装置は、情報処理装置等電波障害自主規制協議会（VCCI）の基準に基づくクラスA情報技術装置です。この装置を家庭環境で使用すると電波妨害を引き起こすことがあります。この場合には使用者が適切な対策を講ずるよう要求されることがあります。

BSMI statement (Taiwan only)

This is a Class A product based on the standard of the Bureau of Standards, Metrology and Inspection (BSMI) CNS 13438 and CNS14336 , Class A.

警告使用者：
這是甲類的資訊產品，在居住的環境中使用時，可能會造成射頻干擾，在這種情況下，使用者會被要求採取某些適當的對策。

MIC notice (Republic of Korea only)

This device has been approved for use in Business applications only per the Class A requirements of the Republic of Korea Ministry of Information and Communications (MIC). This device may not be sold for use in a non-business application.

Observe the Regulatory Marking label on the back or bottom of each switch for specific certification information pertaining to this model. Each Nortel Secure Router 4134 model is approved for shipment to/usage in Korea and is labeled as such, with all appropriate text and the appropriate MIC reference number.

National Safety Statements of Compliance

EN 60950 statement

This is to certify that the Nortel Secure Router 4134 equipment is in compliance with the requirements of EN 60950 in accordance with the Low Voltage Directive. Additional national differences for all European Union countries have been evaluated for compliance.

NOM statement (Mexico only)

The following information is provided on the devices described in this document in compliance with the safety requirements of the Norma Oficial Mexicana (NOM):

Exporter:	Nortel Networks, 5400 Hellyer Ave, San Jose, CA 95138 USA.
Importer:	Nortel Networks de México, S.A. de C.V. Avenida Insurgentes Sur #1605 Piso 30, Oficina Col. San Jose Insurgentes Deleg-Benito Juarez México D.F. 03900
Tel: Fax:	52 5 480 2100 52 5 480 2199
Input:	Nortel Secure Router 4134: <ul style="list-style-type: none"> • PS-SR4K-660W-AC-POE 100-240V ~ 10A/5A 50/60 Hz • PS-SR4K-250W-AC 100-240V ~ 5A/3A 50/60 Hz • PS-SR4K-250W-DC 43-72V 9.5A MAX

Información NOM (unicamente para México)

La información siguiente se proporciona en el dispositivo o en los dispositivos descritos en este documento, en cumplimiento con los requisitos de la Norma Oficial Mexicana (NOM):

Exportador:	Nortel Networks, 5400 Hellyer Ave, San Jose, CA 95138 USA.
Importador:	Nortel Networks de México, S.A. de C.V. Avenida Insurgentes Sur #1605 Piso 30, Oficina Col. San Jose Insurgentes Deleg-Benito Juarez México D.F. 03900
Tel: Fax:	52 5 480 2100 52 5 480 2199
Embarcar a:	Nortel Secure Router 4134: <ul style="list-style-type: none">• PS-SR4K-660W-AC-POE 100-240V ~ 10A/5A 50/60 Hz• PS-SR4K-250W-AC 100-240V ~ 5A/3A 50/60 Hz• PS-SR4K-250W-DC 43-72V 9.5A MAX

Denan statement (Japan/Nippon only)

本製品を安全にご使用頂くため、以下のことにご注意ください。

- 接続ケーブル、電源コード、ACアダプタなどの部品は、必ず製品に同梱されております添付品または指定品をご使用ください。添付品・指定品以外の部品をご使用になると故障や動作不良、火災の原因となることがあります。
- 同梱されております付属の電源コードを他の機器には使用しないでください。上記注意事項を守らないと、死亡や大怪我など人身事故の原因となることがあります。

National Environmental Statements of Compliance

The WEEE Directive 2002/96/EC and RoHS (Restriction of Hazardous Substances) Directive 2002/95/EC sets collection, recycling and recovery targets for various categories of electrical products and their waste.

RoHS Directive Compliance Statement

The Restriction on Hazardous Substances Directive (RoHS) (2002/95/EC), which accompanies the WEEE Directive, bans the use of heavy metals and brominated flame-retardants in the manufacture of electrical and electronic equipment. Specifically, restricted materials under the RoHS Directive are Lead (including solder used in PCB's), Cadmium, Mercury, Hexavalent Chromium, and Bromine.

Nortel declares compliance with the European Union (EU) RoHS Directive (2002/95/EC).

WEEE Directive Compliance Statement

	<p>This product at end of life is subject to separate collection and treatment in the EU Member States, Norway, and Switzerland and therefore is marked with the symbol shown at the left. Treatment applied at end of life of these products in these countries shall comply with the applicable national laws implementing Directive 2002/96/EC on Waste of Electrical and Electronic Equipment (WEEE).</p> <p>Nortel declares compliance with the European Union (EU) WEEE Directive (2002/96/EC).</p>
---	---

Safety messages

This section describes the precautionary notices you find in this document. This section also contains precautionary notices that you must read for safe operation of the Nortel Secure Router 4134.

Notices

Notice paragraphs alert you about issues that require your attention. The following paragraphs describe the types of notices used in this guide. For translations of safety messages, see [“Translations of safety messages” \(page 63\)](#).

ATTENTION

An attention notice provides important information regarding the installation and operation of Nortel products.



CAUTION ESD

ESD notices provide information about how to avoid discharge of static electricity and subsequent damage to Nortel products.



CAUTION ACHTUNG ESD

ESD-Hinweise bieten Information dazu, wie man die Entladung von statischer Elektrizität und Folgeschäden an Nortel-Produkten verhindert.



CAUTION

Caution notices provide information about how to avoid possible service disruption or damage to Nortel products.



**CAUTION
ACHTUNG**

Achtungshinweise bieten Informationen dazu, wie man mögliche Dienstunterbrechungen oder Schäden an Nortel-Produkten verhindert.



WARNING

Warning notices provide information about how to avoid personal injury when working with Nortel products.



**WARNING
WARNUNG**

Warnhinweise bieten Informationen dazu, wie man Personenschäden bei der Arbeit mit Nortel-Produkten verhindert.



DANGER

Danger—High Voltage notices provide information about how to avoid a situation or condition that can cause serious personal injury or death from high voltage or electric shock.



**DANGER
GEFAHR**

Hinweise mit Vorsicht – Hochspannung“ bieten Informationen dazu, wie man Situationen oder Umstände verhindert, die zu schweren Personenschäden oder Tod durch Hochspannung oder Stromschlag führen können.



DANGER

Danger notices provide information about how to avoid a situation or condition that can cause serious personal injury or death.



**DANGER
GEFAHR**

Gefahrenhinweise stellen Informationen darüber bereit, wie man Situationen oder Umständen verhindert, die zu schweren Personenschäden oder Tod führen können.

Cautions and warnings for the Secure Router 4134

The following precautionary messages apply to the Secure Router 4134. For your safety, read these precautions carefully before proceeding with installation of the product.



WARNING

Only qualified service personnel must perform installation. Read and follow all warning notices and instructions marked on the product or included in the documentation. For translations of this statement, see [“Translations of safety messages” \(page 63\)](#).



WARNING WARNUNG

Nur qualifiziertes Wartungspersonal darf die Installation vornehmen. Lesen und befolgen Sie die Warnungshinweise und Anweisungen, die auf dem Produkt gekennzeichnet oder in der Dokumentation enthalten sind.



WARNING

This product relies on the building's installation for overcurrent protection. Ensure that a fuse or circuit breaker no larger than 120 V AC, 15 A U.S. (240 V AC, 10 A international) is used on the phase conductors. For translations of this statement, see [“Translations of safety messages” \(page 63\)](#).



WARNING WARNUNG

Die Nutzung dieses Produkts setzt einen Überstromschutz am Gebäude voraus. Stellen Sie sicher, dass eine Sicherung oder ein Trennschalter mit höchstens 120 V Wechselstrom, 15 A USA (240 V Wechselstrom, 10 A international) bei den Außenleitern verwendet wird.



CAUTION

To reduce the risk of fire, use only number 26 AWG or larger UL Listed or CSA Certified Telecommunication Line Cord for all network connections.



CAUTION ACHTUNG

Um die Feuergefahr zu verringern, verwenden Sie für alle Netzwerkverbindungen nur Nummer 26 der amerikanischen Norm für Drahtquerschnitte oder höher UL-gelistete oder CSA-zertifizierte Netzkabel für Telekommunikation.



CAUTION

Risk of explosion if battery is replaced by an incorrect type. Dispose of used batteries according to the instructions.



**CAUTION
ACHTUNG**

Explosionsgefahr bei Ersetzen der Batterie durch falschen Typ. Entsorgung von gebrauchten Batterien gemäß Anleitung.

Hardware Notice

The Lithium battery in this product is part of a non-volatile memory device and will retain data for 10 years in the absence of power. Nortel does not consider the lithium battery in this unit a field replaceable or serviceable part and should not be accessed by the customer.



DANGER

Risk of injury by electric shock

Before working on this equipment, be aware of proper safety practices and the hazards involved with electrical circuits. Use only power cords that have a grounding path. Ensure the switch is properly grounded before powering on the unit.



DANGER

GEFAHR

Verletzungsrisiko durch Stromschlag

Informieren Sie sich über entsprechende Sicherheitsmaßnahmen und die mit Stromkreisen verbundenen Gefahren, bevor Sie mit diesem Gerät arbeiten. Verwenden Sie nur Netzkabel mit Erdungspfad. Stellen Sie sicher, dass der Schalter ordnungsgemäß geerdet ist, bevor Sie das Gerät einschalten.



WARNING

Risk of eye injury by laser

Fiber optic equipment can emit laser or infrared light that can injure your eyes. Never look into an optical fiber or connector port. Always assume that fiber optic cables are connected to a light source.



WARNING
WARNUNG
Risiko einer Augenverletzung durch Laser

Glasfasergeräte können Laserstrahlen oder ultraviolettes Licht aussenden, das Ihre Augen verletzen kann. Schauen Sie nie direkt in einen Glasfaserleiter oder Verbindungsanschluss. Gehen Sie immer davon aus, dass Glasfaserkabel mit einer Lichtquelle verbunden sind.



CAUTION

If you do not install interface modules in slots, be sure to keep the metal cover plates in place over the slots. Removing the cover plates impedes airflow and proper cooling of the unit. For translations of this statement, see [“Translations of safety messages”](#) (page 63).



CAUTION
ACHTUNG

Wenn Sie in kein Modul in diesem Steckplatz installieren, stellen Sie sicher, dass sich die Abdeckplatte aus Metall weiterhin über dem Steckplatz befindet. Wenn die Metallplatte entfernt wird, behindert dies den Luftstrom und eine angemessene Kühlung der Einheit.



Foreign Exchange Station (FXS) Interface Modules

ATTENTION

Ensure you use standard straight-through RJ11 modular telephone cables with FXS interface modules. TIP must connect to TIP and RING must connect to RING. FXS ground start does not work if polarity is reversed.

ATTENTION

Nortel does not support FXS port connections leaving the building. Use FXS connections for intra-building purposes only.



WARNING

The 2- and 4-port FXS interface modules have a ring signal generator that is a source of hazardous voltage. Do not touch the RJ11 port conductors, the conductors of a cable (that is, the exposed metal ends of a cable connector) connected to the RJ11 port, or the circuit board when the ringer is active (an incoming call activates the ringer).

Foreign Exchange Office (FXO) Interface Modules

ATTENTION

Ensure you use standard straight-through RJ11 modular telephone cables with FXO interface modules. TIP must connect to TIP and RING must connect to RING.

ATTENTION

For connections that pass outside the building in which the Secure Router 4134 resides, you must connect FXO ports through an approved network termination unit that has integrated circuit protection.



WARNING

The 2- and 4-port FXO interface modules have a ring signal generator that is a source of hazardous voltage. Do not touch the RJ11 port conductors, the conductors of a cable (that is, the exposed metal ends of a cable connector) connected to the RJ11 port, or the circuit board when the ringer is active (an incoming call activates the ringer).

Personal safety and equipment protection

Read this section to prevent injury and equipment damage.

Module protection

The following practices prevent equipment damage when you work on the Nortel Secure Router 4134:

- Always wear a grounded antistatic wrist strap when you handle modules.
- Always set modules on appropriate antistatic material.
- Handle modules by the faceplate and handles. Do not touch pins or electrical connections.
- Do not leave interface module or power supply module slots empty. You must fill all slots with modules or slot covers to maintain safety compliance, proper cooling, and electromagnetic interference (EMI) containment in the shelf.

- Ensure that your environment meets the requirements for temperature, humidity, and cleanliness. See “[Environmental requirements](#)” (page 61).
- Do not overtighten thumb screws or lug nuts. Tighten screws and nuts until they are snug, plus a quarter turn. If you use a power tool to tighten screws, use a low torque setting of 2 to 3 in-lb (0.226 to 0.339 N-m).

Cables and connectors protection

The following practices prevent damage to cables and connectors:

- Use caution when connecting cables. Take care to ensure you insert each cable connector in the correct port for the purpose you intend. For example, ensure you connect LAN cables and connectors to LAN ports on the Secure Router 4134.
- Support cables to prevent any stress on the connectors. If you have a high-density cable configuration, use an appropriate cable management system to relieve stress on the cables. Also ensure that cables are threaded neatly and that you employ cable ties as required.
- Do not exceed the bend radius recommended for the type of cable installed.
- Fiber-optic cables and connectors require special care:
 - Cover connectors with rubber safety plugs when they are not connected.
 - Before you install or replace fiber-optic cables, clean the connectors.
 - Do not exceed the bend radius that is recommended for fiber-optic cable. The acceptable bend radius for fiber-optic cable is ten times its diameter, or 2.5 to 5 cm (1 to 2 in.). If you use a radius of less than the recommended bend radius, a loss of signal integrity can result. Loss of signal integrity caused by incorrect bend radius is difficult to diagnose.

Electrostatic discharge

Electrostatic discharge (ESD) is the transfer of charge between objects at different electrical potentials. ESD can change the electrical characteristics of a semiconductor device, and degrade or destroy it. ESD can cause equipment to malfunction or fail.

To dissipate or neutralize electrostatic charges, use proper grounding and use conductive or dissipative materials.

Use a grounded ESD wrist strap. When you use a wrist strap, any charge in your body can go to ground rather than damage a hardware module.

If you must ship the product, ensure you use proper antistatic packaging to shield the product from charge caused by movement of the product within the shipping container.

Antistatic material

Antistatic material prevents electrical damage to equipment, and therefore prevents the interruption of normal operations in an electronic system.

Place modules on an appropriate antistatic material when you replace hardware.

Use an ESD pad or antistatic packaging.

ATTENTION

Some antistatic packaging is effective only on the inside of the package.

New in this release

The following section details what's new in the *Nortel Secure Router 4134 — Quick Start* (NN47263-100) for Release 10.1.

Features

See the following sections for information about feature changes:

- [“Interface modules”](#) (page 21)

Interface modules

Secure Router 4134, Release 10.1, introduces six new external interface modules:

- 2-port FXS Small Module
- 4-port FXS Small Module
- 2-port FXO Small Module
- 4-port FXO Small Module
- Voice Carrier Medium Module
- Mediation Server Module for OCS

Release 10.1 also introduces a new internal module, the Packetized Voice Module (PVM), which provides support for voice functionality.

For detailed information about the modules available in Release 10.1, or for information about the installation of the PVM, see *Nortel Secure Router 4134 Installation — Hardware Components* (NN47263-301).

For information about installing any external interface module, see [“Installing the interface modules”](#) (page 39)

Introduction

Nortel Secure Router 4134 — Quick Start (NN47263-100) provides basic instruction on how to install the hardware and perform initial configuration of the Nortel Secure Router 4134. The Quick Start is intended for experienced installers.

Navigation

- [“Installing the Secure Router 4134 chassis and hardware components” \(page 29\)](#)
- [“Configuring the Secure Router 4134 for remote access” \(page 55\)](#)
- [“Translations of safety messages” \(page 63\)](#)

Secure Router 4134 installation and initial configuration

Install the Secure Router 4134 and log on to prepare the unit for configuration and deployment in your network.

Secure Router 4134 installation and initial configuration tasks

This work flow shows you the sequence of tasks you perform to install the Secure Router 4134 and prepare the unit for system configuration. To link to any task, go to [“Secure Router 4134 installation and initial configuration navigation”](#) (page 27).

Figure 1
Secure Router 4134 installation and initial configuration tasks

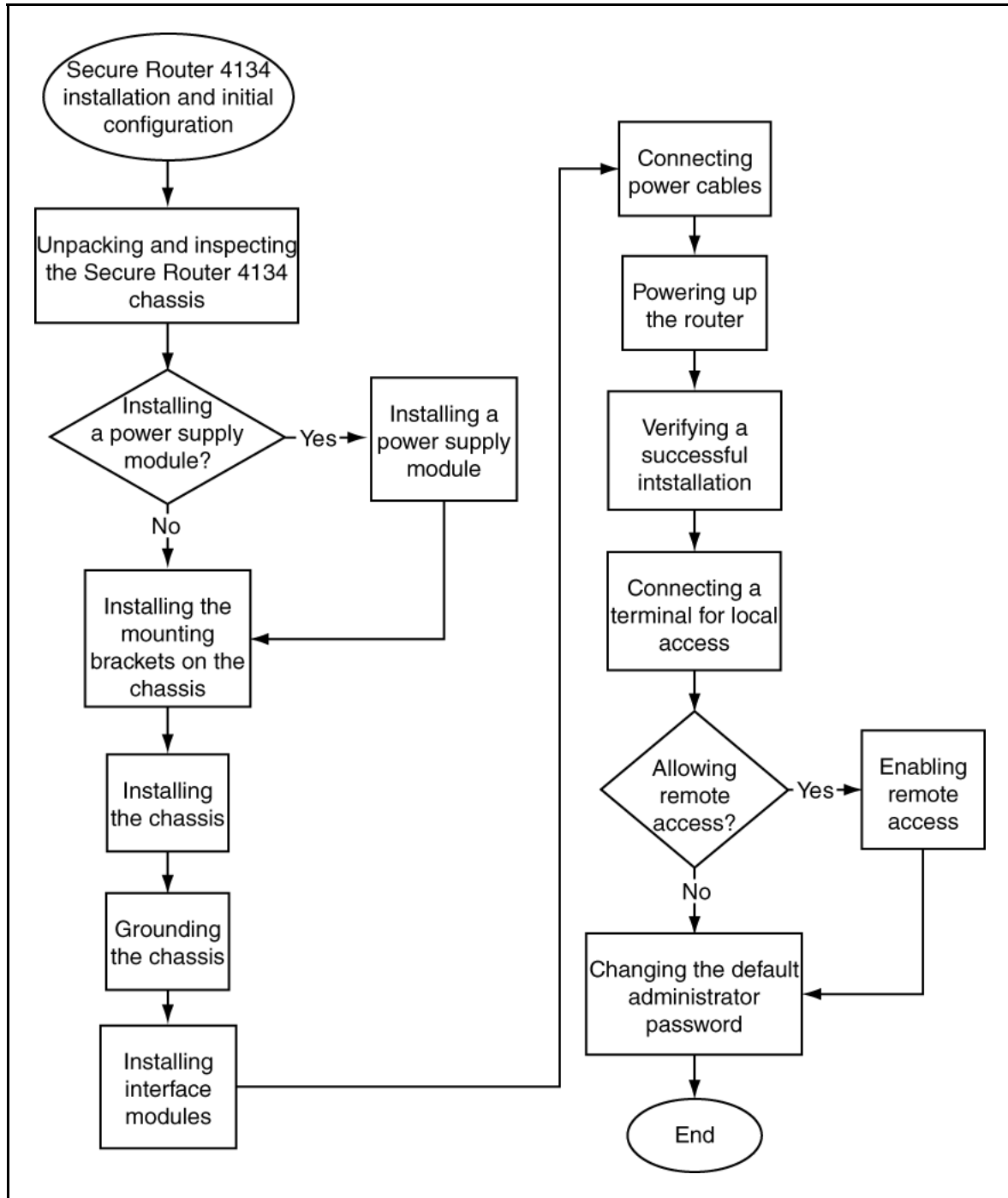

Secure Router 4134 installation and initial configuration navigation

- [“Unpacking and inspecting the Secure Router 4134 chassis” \(page 29\)](#)
- [“Installing a power supply module” \(page 30\)](#)
- [“Installing the mounting brackets on the chassis” \(page 31\)](#)
- [“Installing the chassis” \(page 34\)](#)
- [“Grounding the chassis” \(page 36\)](#)
- [“Installing the interface modules” \(page 39\)](#)
- [“Connecting power cables” \(page 46\)](#)
- [“Powering up the router” \(page 52\)](#)
- [“Verifying a successful installation” \(page 52\)](#)
- [“Connecting a terminal for local access” \(page 55\)](#)
- [“Establishing remote access” \(page 56\)](#)
- [“Changing the default administrator password” \(page 58\)](#)

Installing the Secure Router 4134 chassis and hardware components

For detailed instructions about how to install the Secure Router 4134 and its hardware components, see *Nortel Secure Router 4134 Installation — Chassis* (NN47263-300) and *Nortel Secure Router 4134 Installation — Hardware Components* (NN47263-301).

The Secure Router 4134 ships with the fan tray installed, as well as the power supply unit or units that you ordered. If you must replace a fan tray or power supply unit, or if you choose to install a second power supply unit, see *Nortel Secure Router 4134 Installation — Hardware Components* (NN47263-301).

Unpacking and inspecting the Secure Router 4134 chassis

Use the information in this section to verify you have received all accessories that ship with the Secure Router 4134.

Procedure steps

Step	Action
1	Remove the shipping container.
2	Place the chassis on antistatic material.
3	Check all items for damage.

--End--

ATTENTION

If you detect any damage, do not install the chassis. Call the Nortel Technical Solutions Center in your area.

The following table lists the accessories you can find in the shipping container with the Secure Router 4134. Place a mark in the third column of the table to verify that you have received each accessory.

Table 1
Secure Router 4134 accessories

Accessory	Function	Verified
Rack mounting bracket kit that contains two rack mounting brackets and 20 Phillips-head screws.	Supports the chassis in an equipment rack. The screws for the mounting brackets are 8-32 x 1/4 in. (12). There are two types of screws for the rack mount: For telecom racks—12-24 x 5/8 in. Phillips (4) For cabinets—10-32 x 1/2 in. Phillips (4)	
Console cable	Connects a management console to the chassis.	
Female DB-9 to RJ-45 connector	Use, if necessary, to connect the console cable to a terminal or PC.	
Power cord	Country-specific power cord provided for AC input. One power cord is provided for each power supply module you ordered. The power cord is a no-charge item that is supplied with the chassis, however it must appear as a separate item on your order.	
Terminal (ground) lug and two screws	Connects the ground wire to the front panel of the chassis. Screws: 8-32 x .187-in. pan head screws with external tooth washer (2)	
Software and documentation CD	Contains the Secure Router 4134 software image file, as well as the installation and configuration manuals.	

Installing a power supply module

The Secure Router 4134 operates with one or two AC power supplies, one or two DC power supplies, or one AC and one DC power supply. You install the power supplies at the rear of the unit.

Average time to install one power supply module: 1 minute.



CAUTION

Risk of equipment damage

Watch the power supply status LED for alerts if you hot swap a power supply module.



CAUTION

ACHTUNG

Risiko eines Geräteschadens

Achten Sie auf Warnungen auf der Status-LED des Netzteils, wenn Sie das Netzteilmodul ohne Stromabschaltung austauschen.



**CAUTION
ESD**

To prevent damage from electrostatic discharge, always wear an antistatic wrist strap connected to an electrostatic discharge (ESD) jack when performing maintenance on this product. Ensure that the wrist strap makes contact with your skin.



**CAUTION
ACHTUNG
ESD**

Um Schäden durch elektrostatische Entladung zu verhindern, tragen Sie bei der Instandhaltung dieses Produkts immer ein antistatisches Band am Handgelenk, das mit einer ESD-Buchse verbunden ist. Stellen Sie sicher, dass das Band am Handgelenk Kontakt zur Haut hat.

Prerequisites

- Ensure you have the power supply module for the Secure Router 4134.
- Ensure you have a Phillips #2 screwdriver.

Procedure steps

Step	Action
1	Using a Phillips screwdriver, loosen the two screws that secure the metal plate that covers the slot in which you want to install the power supply unit.
2	Remove the cover plate.
3	Insert the power supply module in the power supply slot.
4	Push the power supply module gently, but firmly, to insert it fully into the internal connection port. When the power supply is fully inserted, the front of the power supply module is flush with the rear panel of the router.
5	Secure the power supply in the chassis by tightening the two retaining screws.

--End--

Installing the mounting brackets on the chassis

You must install the mounting brackets on the Secure Router 4134 before installing the chassis in an equipment rack. You can mount the Secure Router 4134 with either the front panel or the back panel facing the operator. The following table shows the six possible mounting positions.

Average time to install mounting brackets: 2 minutes.

Table 2
Mounting bracket installation options

Position	Description
Position 1 with front panel facing operator	
Position 2 with front panel facing operator	
Position 3 with front panel facing operator	

Table 2
Mounting bracket installation options (cont'd.)

Position	Description
Position 1 with rear panel facing operator	
Position 2 with rear panel facing operator	
Position 3 with rear panel facing operator	

Prerequisites

- Ensure you have the rack mounting brackets and screws that shipped with the Secure Router 4134.
- Ensure you have a Phillips #2 screwdriver.

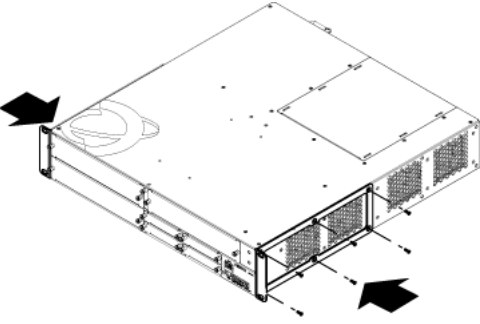
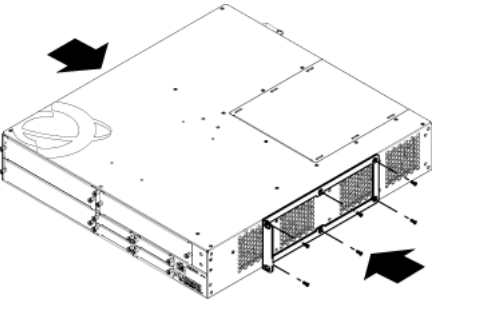
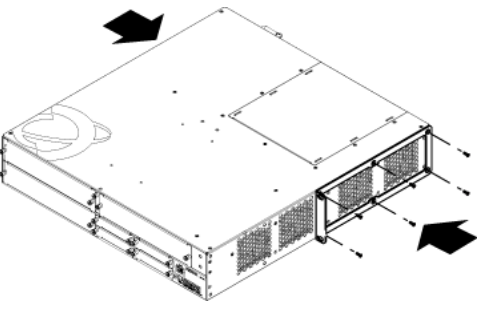
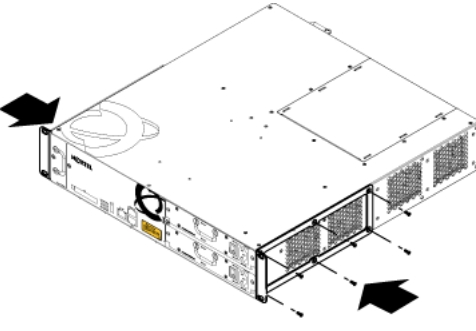
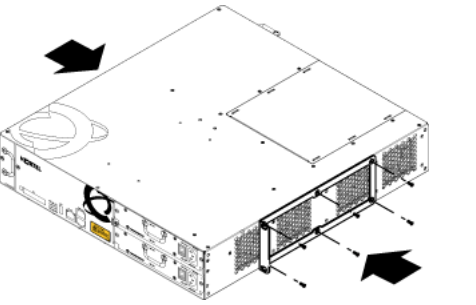
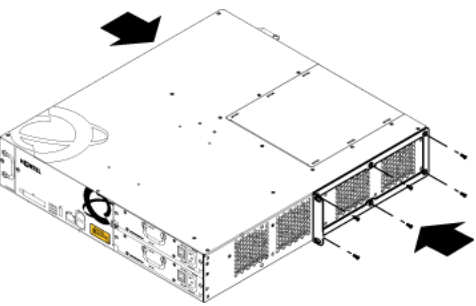
Procedure steps

Step	Action
1	Select one of the six possible rack-mounting positions on the sides of the Secure Router 4134.
2	Use a #2 Phillips screwdriver to attach a bracket to the desired mounting position on one side of the Secure Router 4134.
3	Torque the mounting bracket screws to 3 to 6 in-lb (0.339 to 0.6779 N-m).
4	Attach the second bracket to the corresponding position on the opposite side of the Secure Router 4134.

--End--

Installing the chassis

Install the Secure Router 4134 in a standard equipment rack (19 in; 48.26 cm).

Average time to install the Secure Router 4134 chassis in an equipment rack: 2 minutes.

ATTENTION

You must install the Secure Router 4134 in a restricted-access location. You must limit access to the Secure Router 4134 to authorized service personnel only.

ATTENTION

Nortel recommends that you install the chassis (including the power supplies and fan tray) in the equipment rack before you install the ground lug and the optional external interface modules.



WARNING

Do not install the Secure Router 4134 near a standing or running water source or in a high-humidity environment.



**WARNING
WARNUNG**

Installieren Sie den Secure Router 4134 nicht in der Nähe von stehenden oder fließenden Gewässern oder in einem Gebiet mit sehr hoher Feuchtigkeit.

**WARNING****Risk of injury**

The Secure Router 4134 weighs approximately 25 lb (11.34 kg) with one power supply and the fan tray installed. To prevent injury, keep your back straight and lift with your legs, not your back.

**WARNING****WARNUNG****Verletzungsrisiko**

Der Secure Router 4134 wiegt mit einem Netzteil und dem Lüftereinsatz ungefähr 11,34 kg (25 lb). Um Verletzungen zu verhindern, halten Sie den Rücken gerade und heben Sie nicht mit dem Rücken, sondern den Beinen.

**CAUTION****Risk of equipment damage**

Only trained personnel can install this product.

**CAUTION****ACHTUNG****Risiko eines Geräteschadens**

Nur geschultes Personal kann dieses Produkt installieren.

**CAUTION****Risk of equipment damage**

To prevent damage from electrostatic discharge, always wear an antistatic wrist strap connected to an ESD jack.

**CAUTION****ACHTUNG****Risiko eines Geräteschadens**

Um Schäden durch elektrostatische Entladung zu verhindern, tragen Sie bei der Instandhaltung dieses Produkts immer ein antistatisches Band am Handgelenk, welches mit einer ESD-Buchse verbunden ist.

Prerequisites

- Confirm that your shipment is complete and undamaged.
- Ensure you have allotted adequate space in and around the equipment rack for installation of the Secure Router 4134.
- Ensure you have the screws that shipped with the chassis.

- Ensure you have a Phillips screwdriver #2.
- Ensure the mounting brackets are firmly installed on the chassis.
- Ensure you have appropriate antistatic materials.
- Nortel recommends you have two people to help lift the chassis into the equipment rack and securing it.
- Ensure your installation site meets the physical, electrical, and environmental requirements described in [“Environmental requirements” \(page 61\)](#). Site location is important for the proper operation of the Secure Router 4134. Place the unit in a clean, dry environment with adequate air circulation. Allow 2 to 3 feet (0.61 to 0.91 m) of additional clearance around the Secure Router 4134 for access to the cable connectors on the front and rear panels.

Procedure steps

Step	Action
1	With two people, lift the chassis into available rack space.
2	Ensure that the chassis is level, and align the screw holes on the chassis brackets with those on the equipment rack.
3	Insert the mounting screws. Space the screws evenly to hold the chassis in the frame.

--End--

Grounding the chassis

You must properly ground the Secure Router 4134 before you place it in service. You can connect your ground wire to the grounding strip of the equipment rack, but you must also ensure that the equipment rack is properly grounded.

For all installations, you must provide proper grounding through a UL listed terminal attached to the grounding location on the front panel of the router. The grounding lug, as well as the screws and washers necessary to attach it to the Secure Router 4134, ship in the container with the Secure Router.

Average time to install the grounding terminal: 1 minute.

ATTENTION

You must install the Secure Router 4134 in a restricted-access location. You must limit access to the Secure Router 4134 to authorized service personnel only.

Prerequisites

- Ensure you have the terminal lug and the associated screws and washers that shipped with the Secure Router 4134 chassis (two 8-32 x .187" pan head screws with external tooth washer).
- Ensure you have a Phillips #2 screwdriver.
- An external DC power source that provides overcurrent protection of 12 amps (125 percent of the maximum Secure Router 4134 rating).
- Ensure you have a sufficient length of 8 AWG copper wire for the ground lead.
- Attach a UL listed terminal, suitable for your equipment rack, to the end of the ground wire.
- You must have a crimping tool to attach the grounding wire to the supplied terminal (lug).

**WARNING**

Disconnect the Secure Router 4134 from all power sources (AC and DC) before servicing.

**WARNING**

La prudence: Protéger contre le risque de choc électrique, débrancher les cordes d'alimentation et DC télégraphiant avant d'entretenir.

**WARNING
WARNUNG**

Trennen Sie den Secure Router 4134 vor der Instandhaltung von allen Stromquellen (Gleichstrom und Wechselstrom).

ATTENTION

You must connect grounding wires to the ground terminal when DC power is supplied from external power supplies.

ATTENTION**ACHTUNG**

Sie müssen Schutzleitungen mit dem Erdanschluss verbinden, wenn der Wechselstrom von externen Netzteilen stammt.

**CAUTION**

As a general safety precaution, ensure you provide DC power through a circuit breaker on the equipment rack.



CAUTION
ACHTUNG

Stellen Sie als allgemeine Sicherheitsmaßnahme sicher, dass der Wechselstrom durch einen Trennschalter auf dem Geräteträger fließt.

For more information, see the guidelines presented in Articles 110-16, 110-17, and 110-18 of the National Electric Code, ANSI/NFPA 70.

Procedure steps

Step	Action
1	Insert available ground wire in the ground lug (provided).
2	Crimp the barrel of the terminal lug to secure the ground wire.
3	Remove the sticker label affixed on the front panel of the unit (in the upper right corner).
4	Secure the ground lug with two 8-32 screws and washers (provided), ensuring the barrel faces down, as shown in the following figure.

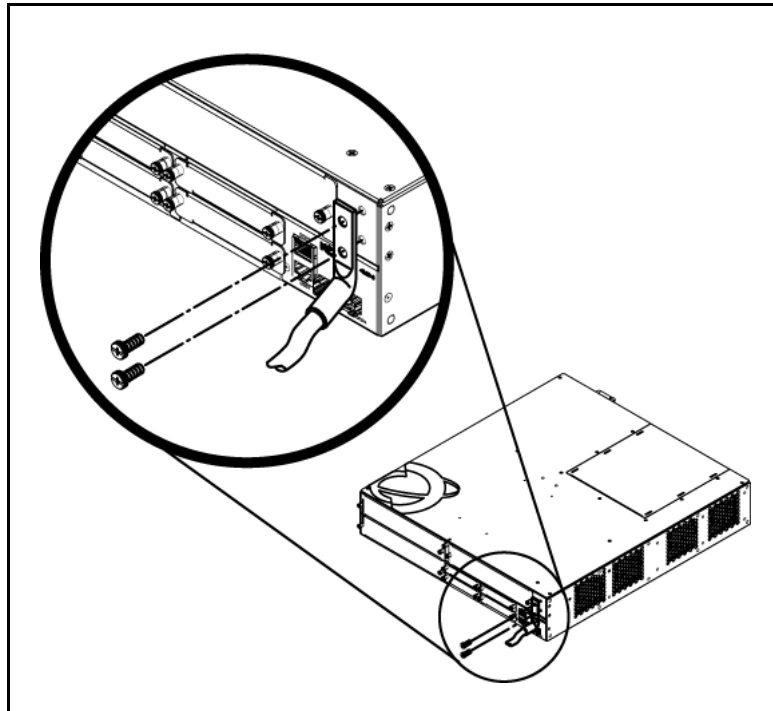

--End--

Installing the interface modules

Install the optional interface modules in the front panel of the Secure Router 4134 chassis.

Nortel strongly recommends that you power down the Secure Router 4134 if you are installing an interface module in a slot in which you have not previously installed that module type. If you do not power down the router to install a module, you must reboot the router to use the card. After a module is installed and initialized, you can hot swap that module.

The chassis has horizontal slots for small, medium, and large interface modules. The chassis ships with four small slots, and three medium slots. You can adapt two of the medium slots to accommodate a large module (which spans two medium slots). You must separately order the modules.

The following figure shows the default slot configuration and indicates how slots are numbered on the Secure Router 4134.

Figure 2
Slot numbering on the Secure Router 4134

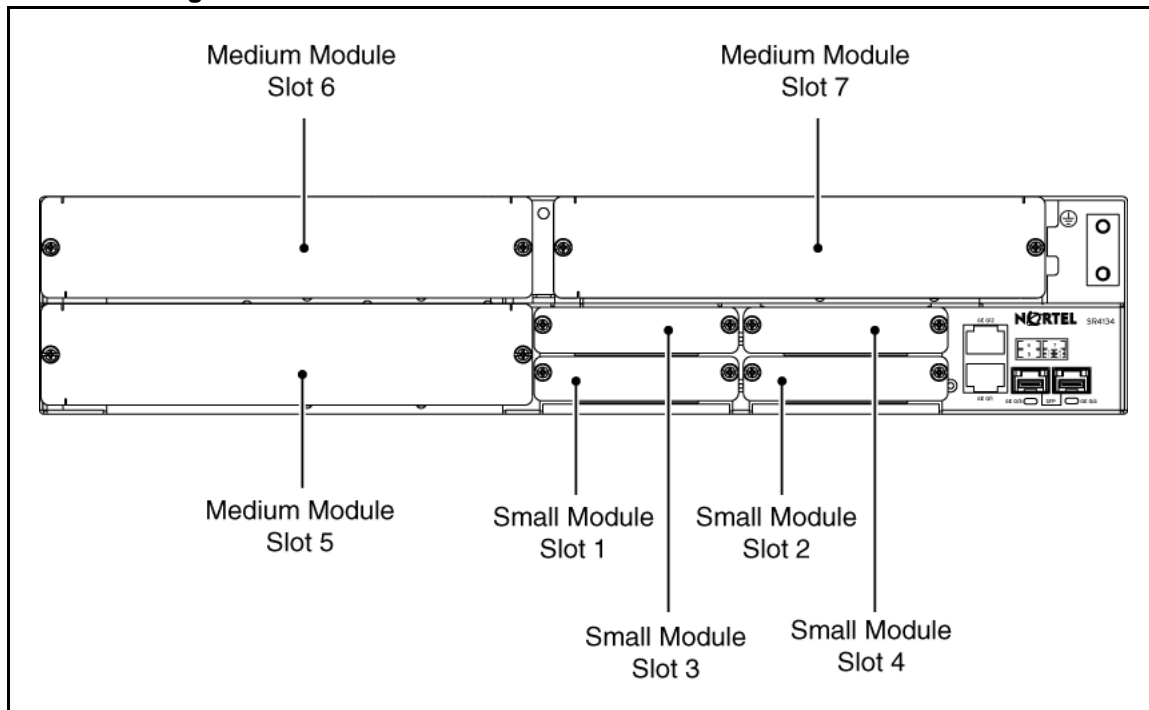

A slot numbering legend is printed directly above the chassis SFP Ethernet ports (ports 0/3 and 0/4) on the front panel of the Secure Router 4134. The legend shows how slots are numbered on the Secure Router 4134. The following figure shows the slot numbering legend.

Figure 3
Slot numbering legend printed on the Secure Router 4134

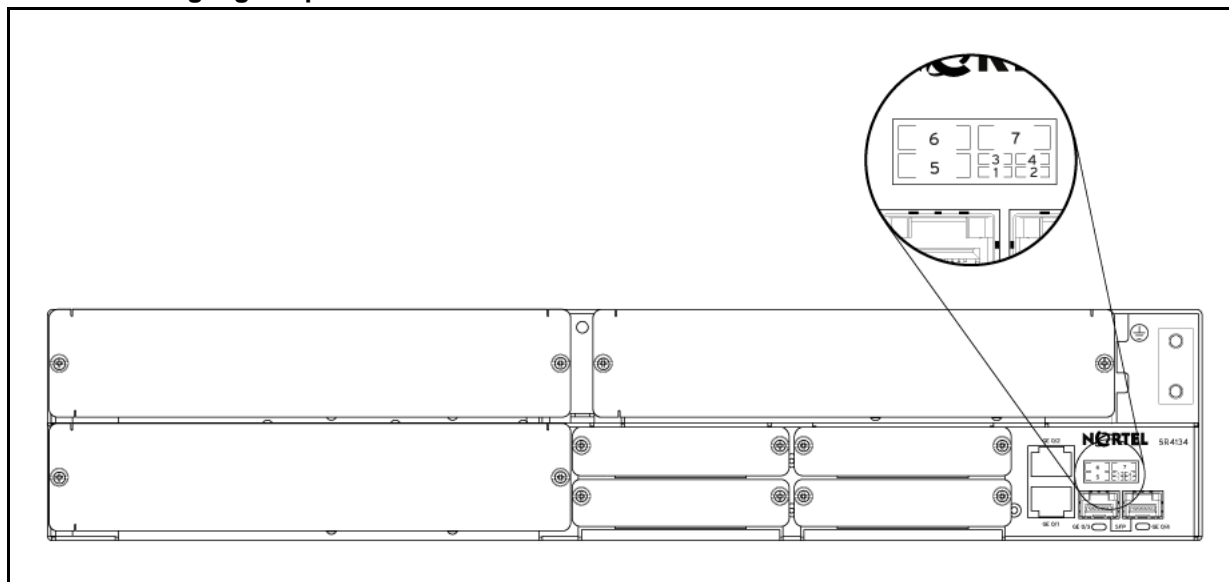

Slots 1 to 4 are Small Module slots. Slots 5 to 7 are Medium Module slots. If you insert a Large Module, it spans slots 6 and 7. If you install a Large Module, slots 6 and 7 become slot 6.

For detailed information about the Secure Router 4134 modules, see *Nortel Secure Router 4134 Installation — Hardware Components* (NN47263-301).

Average time to install an interface module: 1 minute.



CAUTION
ESD

To prevent damage from electrostatic discharge, always wear an antistatic wrist strap connected to an ESD jack when you work with interface modules. The router does not have an ESD jack—connect the antistatic wrist strap to an ESD jack at your site.



CAUTION
ACHTUNG
ESD

Um Schäden durch elektrostatische Entladung zu verhindern, tragen Sie bei der Arbeit mit Interfacemodulen immer ein antistatisches Band am Handgelenk, das mit einer ESD-Buchse verbunden ist. Der Verteiler hat keine ESD-Buchse – verbinden Sie das antistatische Band am Handgelenk mit der ESD-Buchse an Ihrem Platz.

**CAUTION****Risk of equipment damage**

Always handle interface modules by the edges, or use the levers, where applicable.

**CAUTION****ACHTUNG****Risiko eines Geräteschadens**

Berühren Sie Interfacemodule immer an den Rändern, oder verwenden Sie die Hebel, sofern vorhanden.

Prerequisites

- Ensure you have a Phillips #2 screwdriver.

Installing a Small Module

Use the procedure in this section to install a Small Module in the Secure Router 4134. You can install Small Modules in slots 1, 2, 3, and 4.

ATTENTION

Slot 2 of the Secure Router 4134 supports only one port of any WAN data Small Module. If you install a 2-port Small Module in Slot 2, and use the Small Module for data connections, one port only is functional (port 1).

This limitation also applies to the 2-port T1/E1 and ISDN BRI Small Modules if they are configured for voice traffic: only port 2/1 is functional. This limitation does not apply to FXS or FXO voice modules.

If you are working with 2- or 4-port FXS or FXO Small Modules, ensure you read the safety messages related to the FXS and FXO interface modules. See [“Foreign Exchange Station \(FXS\) Interface Modules”](#) (page 17) and [“Foreign Exchange Office \(FXO\) Interface Modules”](#) (page 18).

For instructions to install a Small Module in the Voice Carrier Medium Module, see [“Installing a Small Module in the Voice Carrier Medium Module”](#) (page 43).

Procedure steps

Step	Action
1	Use a Phillips screwdriver to remove the slot cover plate from the slot in which you will install the module.
2	Align the module with the slot and the slot module guides.
3	Slide the module into the chassis until its connector panel touches the chassis back panel.

- 4 Push gently, but firmly, to seat the connector on the interface module in the chassis back panel.
- 5 Use a Phillips screwdriver to tighten the two captive screws to secure the module to the chassis.

--End--

Installing a Medium Module

Use the procedure in this section to install a Medium Module in the Secure Router 4134. You can install Medium Modules in slots 5, 6, and 7.

ATTENTION

If you use a Voice Carrier Medium Module with the Secure Router 4134, Nortel recommends you install the Voice Carrier Medium Module in the chassis before installing Small Modules in the Voice Carrier Medium Module.

Procedure steps

Step	Action
1	Use a Phillips screwdriver to remove the slot cover plate from the slot in which you will install the module.
2	Align the module with the slot and the slot module guides.
3	Slide the module into the chassis until its connector panel touches the chassis back panel.
4	Push gently, but firmly, to seat the connector on the interface module in the chassis back panel.
5	Ensure the lever on the module is flush with the front panel of the Secure Router 4134.
6	Use a Phillips screwdriver to tighten the two captive screws to secure the module to the chassis.

--End--

Installing a Large Module

Use the procedure in this section to install a Large Module in the Secure Router 4134. You can install a Large Module to span slots 6 and 7 only.

Procedure steps

Step	Action
1	Use a Phillips screwdriver to remove the slot cover plates from slots 6 and 7.

- 2 Loosen the captive screw at the top of the center slot module guide.
- 3 Remove the center slot module guide. The following figure shows the removal of the center slot module guide.

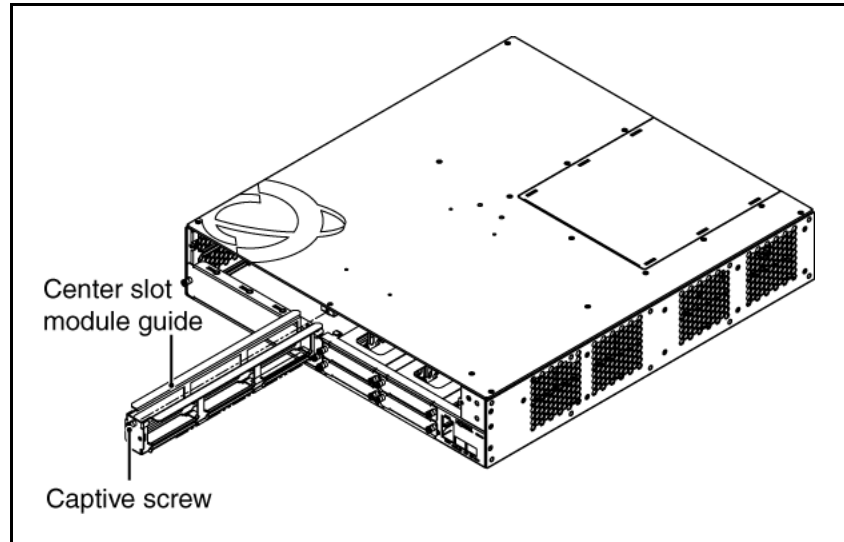

- 4 Align the Large Module with the slot and the slot module guides on the outside edges of the slot.
- 5 Slide the module into the chassis until its connector panel touches the chassis back panel.
- 6 Push gently, but firmly, to seat the connector on the interface module in the chassis back panel.
- 7 Ensure the levers on the module are flush with the front panel of the Secure Router 4134.
- 8 Use a Phillips screwdriver to tighten the two captive screws to secure the module to the chassis.

--End--

Installing a Small Module in the Voice Carrier Medium Module

Ensure you securely install the Voice Carrier Medium Module in the Secure Router 4134 chassis before you install Small Modules in the Voice Carrier Medium Module. For instructions to install the Voice Carrier Medium Module in the chassis, see [“Installing a Medium Module”](#) (page 42).

If you are working with 2- or 4-port FXS or FXO Small Modules, ensure you read the safety messages related to the FXS and FXO interface modules. See [“Foreign Exchange Station \(FXS\) Interface Modules”](#) (page 17) and [“Foreign Exchange Office \(FXO\) Interface Modules”](#) (page 18).

The following figure shows the slot numbering on the Voice Carrier Medium Module—slot numbers are printed on the module, as well.

Figure 4
Voice Carrier Medium Module slot numbering

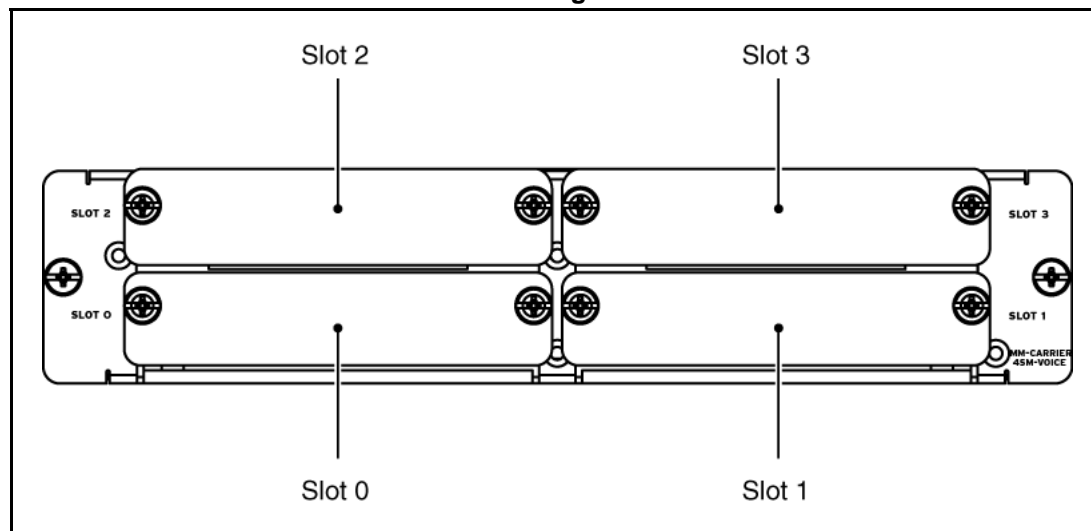

For detailed information about the Voice Carrier Medium Module, see *Nortel Secure Router 4134 Installation — Hardware Components* (NN47263-301).

Average time to install a Small Module in the Voice Carrier Medium Module: 1 minute



CAUTION
ESD

To prevent damage from electrostatic discharge, always wear an antistatic wrist strap connected to an ESD jack when you work with interface modules. The router does not have an ESD jack—connect the antistatic wrist strap to an ESD jack at your site.



CAUTION
ACHTUNG
ESD

Um Schäden durch elektrostatische Entladung zu verhindern, tragen Sie bei der Arbeit mit Interfacemodulen immer ein antistatisches Band am Handgelenk, das mit einer ESD-Buchse verbunden ist. Der Verteiler hat keine ESD-Buchse – verbinden Sie das antistatische Band am Handgelenk mit der ESD-Buchse an Ihrem Platz.

**CAUTION****Risk of equipment damage**

Always handle interface modules by the edges, or use the levers, where applicable.

**CAUTION****ACHTUNG****Risiko eines Geräteschadens**

Berühren Sie Interfacemodule immer an den Rändern, oder verwenden Sie die Hebel, sofern vorhanden.

**CAUTION**

If you do not install a module in the slot, be sure to keep the metal cover plate in place over the slot. Removing the cover plate impedes airflow and proper cooling of the unit.

**CAUTION****ACHTUNG**

Wenn Sie in kein Modul in diesem Steckplatz installieren, stellen Sie sicher, dass sich die Abdeckplatte aus Metall weiterhin über dem Steckplatz befindet. Wenn die Metallplatte entfernt wird, behindert dies den Luftstrom und eine angemessene Kühlung der Einheit.

Prerequisites

- Ensure you have a Phillips #2 screwdriver.
- Ensure you have securely installed the Voice Carrier Medium Module in the Secure Router 4134 chassis.

Procedure steps

Step	Action
1	Use a Phillips screwdriver to remove the slot cover plate from the slot in which you will install the Small Module.
2	Align the Small Module with the slot and the slot module guides.
3	Slide the Small Module into the Voice Carrier Medium Module until the Small Module connector touches the back panel of the Voice Carrier Medium Module.
4	Push gently, but firmly, to seat the Small Module connector in the Voice Carrier Medium Module.

- 5 Use a Phillips screwdriver to tighten the two captive screws that secure the Small Module to the Voice Carrier Medium Module.

--End--

Connecting power cables

The following two types of power supply modules are available for the Secure Router 4134:

- AC power supply module (standard or PoE) requiring an external AC power source
- DC power supply module requiring an external DC power source

Use the procedures in this section to connect AC and DC power cables to a Secure Router 4134.

Connecting AC power cables

Average time to install one AC power cable: 1 minute.



CAUTION ESD

Always wear an ESD-preventative wrist strap when you connect cables or perform maintenance on a Secure Router 4134. Ensure that the wrist strap makes contact with your skin.



CAUTION ACHTUNG ESD

Um Schäden durch elektrostatische Entladung zu verhindern, tragen Sie bei der Instandhaltung dieses Produkts immer ein antistatisches Band am Handgelenk, das mit einer ESD-Buchse verbunden ist. Stellen Sie sicher, dass das Band am Handgelenk Kontakt zur Haut hat.

Prerequisites

- Ensure you have one or two appropriately rated AC power cords, depending on your configuration. Power cords ship with the Secure Router 4134 chassis.
- Ensure the power cord or cords are long enough to plug the male end into a standard 110/220 V AC power outlet.

Procedure steps

Step	Action
1	Insert the female end of an appropriately rated AC power cord in the AC receptacle on the rear panel of the Secure Router 4134, as shown in the following figure.

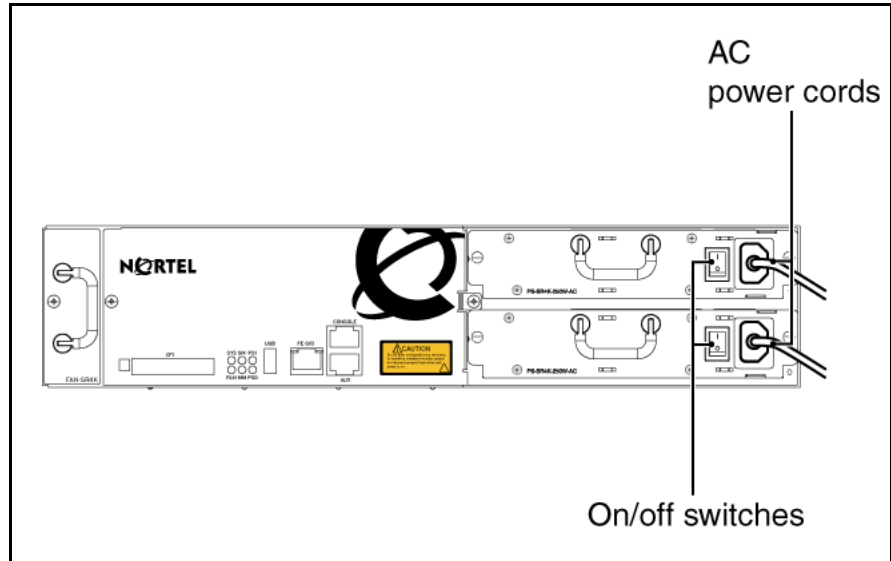

2	Insert the male end of the power cord in a standard 110/220 V AC power outlet.
---	--

**CAUTION**

Ensure you use an appropriately rated AC power cord only. Do not use an extension cord.

**CAUTION
ACHTUNG**

Stellen Sie sicher, dass Sie nur ein angemessen bewertetes Netzkabel für Gleichstrom verwenden. Verwenden Sie kein Verlängerungskabel.

--End--

Connecting DC power

The following figure shows the location of the terminal block on the DC power supply module.

Figure 5
Secure Router 4134 DC power supply terminal block

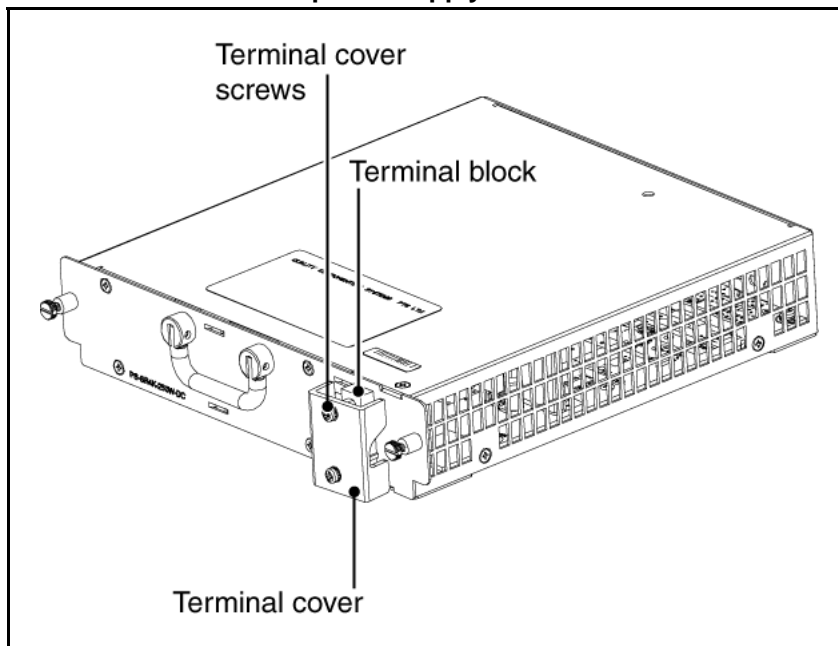

Average time to install one DC power cable: 3 minutes.



CAUTION
ESD

Always wear an ESD-preventative wrist strap when you connect cables or perform maintenance on a Secure Router 4134. Ensure that the wrist strap makes contact with your skin.



CAUTION
ACHTUNG
ESD

Um Schäden durch elektrostatische Entladung zu verhindern, tragen Sie bei der Instandhaltung dieses Produkts immer ein antistatisches Band am Handgelenk, das mit einer ESD-Buchse verbunden ist. Stellen Sie sicher, dass das Band am Handgelenk Kontakt zur Haut hat.



CAUTION

As a general safety precaution, ensure you provide DC power through either a fuse or DC circuit breaker with a maximum rating of 12 amps.



CAUTION
ACHTUNG

Stellen Sie als allgemeine Sicherheitsmaßnahme sicher, dass der Wechselstrom entweder durch eine Sicherung oder einen Wechselstromsicherung mit maximal 12 A fließt.

Prerequisites

- Ensure you have 18 AWG copper wire with appropriate terminal (lug). You require two wires for single source power, and four wires for redundant power supplies (that is, two wires for each input).
- Ensure you have a Phillips #2 screwdriver.
- Ensure you have a flathead screwdriver to tighten terminals.



DANGER

Ensure that you remove the proper amount of insulation from copper wires when you install the terminals (lugs). Ensure that no wires are exposed.



DANGER
GEFAHR

Stellen Sie sicher, dass Sie das richtige Maß an Isolierung von den Kupferkabeln entfernen, wenn Sie die Anschlüsse (Klemmen) installieren. Stellen Sie sicher, dass keine Kabel freiliegen.

Procedure steps

Step	Action
------	--------

- | | |
|---|---------------------------------|
| 1 | Switch off the DC power source. |
|---|---------------------------------|



DANGER

Before you continue with this procedure, ensure that the DC power source is switched off.



DANGER
GEFAHR

Bevor Sie dieses Verfahren fortsetzen, stellen Sie sicher, dass die Stromquelle für Wechselstrom ausgeschaltet ist.

- | | |
|---|---|
| 2 | Loosen both terminal cover screws on the DC power supply, as shown in the following figure. |
|---|---|

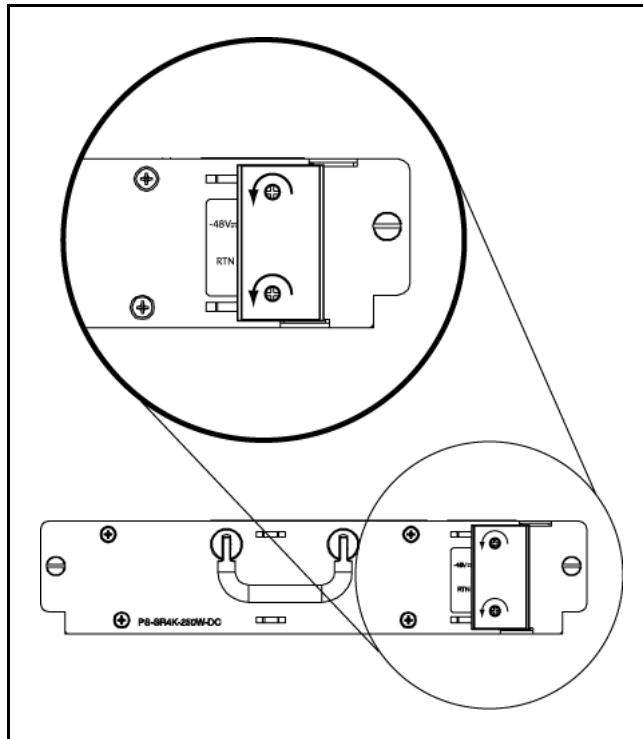

- 3 Remove the terminal cover to expose the terminal block.
- 4 Insert the -48 V lead behind the -48 V terminal, as shown in the following figure.

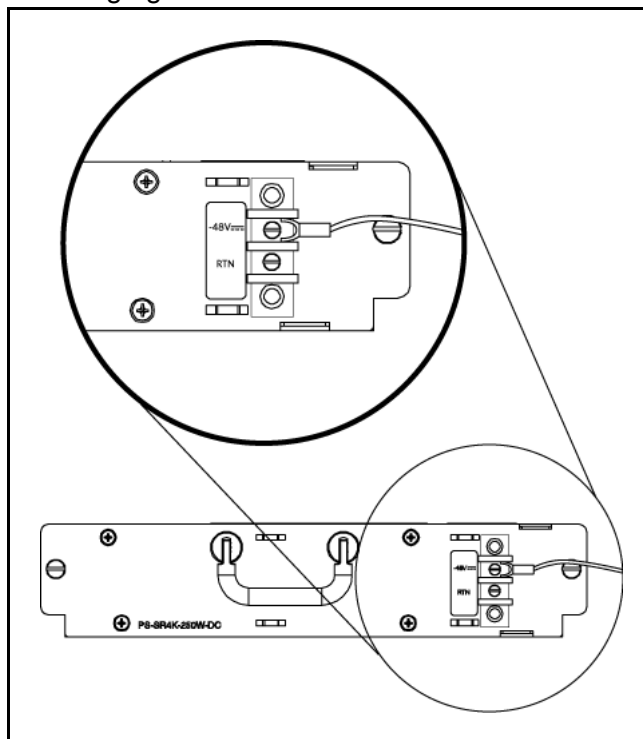

- 5 Tighten the -48 V terminal to hold the lug and wire in place. The maximum tightening torque for terminal screws is 9 in-lb (1.02 N-m).
- 6 Insert the $+48\text{ V}$ return lead behind the RTN terminal, as shown in the following figure.

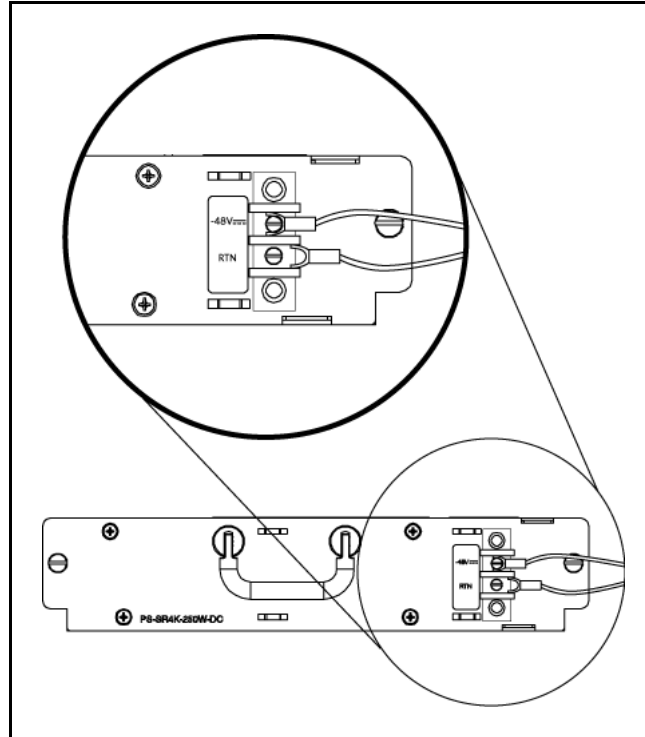

- 7 Tighten the RTN terminal to hold the lug and wire in place. The maximum torque for tightening terminal screws is 9 in-lb (1.02 N-m).
- 8 Place the terminal cover over the terminal block.
- 9 Replace the terminal cover screws. The maximum torque for tightening terminal cover screws is 4 in-lb (0.45 N-m).
- 10 Use a cable tie to bind the wires. Use at least four cable ties spaced at four-inch intervals. Place the first tie within six inches of the terminal block. Position the bound wires to prevent accidental contact when passing by the Secure Router 4134.
- 11 Attach the other ends of the leads to a -48 V DC power source.

--End--

Powering up the router

Use the procedure in this section to power up your Secure Router 4134.

Prerequisites

- Ensure all installation procedures are complete.
- Ensure an operator console is connected to the Secure Router 4134.
- Ensure the Secure Router 4134 is connected to a power source.

Procedure steps

Step	Action
1	For an AC power supply, press the rocker switch located on the power supply to the on position ().
2	On a DC power supply, ensure the DC power source is on.
3	Verify that the power supply status LED for each power supply is green.
4	Verify that the fan status LED is green.
5	Verify that the air flows from the cooling fans through the vents of the chassis. The fan tray red (fail) LED can illuminate briefly while the fans power to operational speed.

--End--

If status LEDs do not illuminate green, see *Nortel Secure Router 4134 — Troubleshooting* (NN47263-700).

Verifying a successful installation

Use the information in this section to verify that you have successfully installed the Secure Router 4134 and its components.

If any LED behavior indicates failure or is suspect, see *Nortel Secure Router 4134 — Troubleshooting* (NN47263-700).

In a normal power-up sequence, the following events occur:

1. When you power up the router, the fans start and the Secure Router 4134 performs a self-test.
2. At the successful conclusion of the self-test sequence, LED activity begins. The following table describes LED behavior at power-up.

Table 3
Secure Router 4134 LED behavior at power-up

Front panel LEDs	Rear panel LEDs	Description
	SYS	Illuminate red, and then green
	FAN	Illuminate red, and then green
	PS0 and PS1	Illuminate green for each power supply module that is installed.
	SM and MM	Illuminate green if Small and Medium Modules are installed. The MM LED also monitors a Large Module, if installed.
Module status and link status LEDs		Illuminate in various states until you configure the Secure Router 4134 for specific network line conditions. Generally, the status LEDs on interface modules illuminate yellow initially, and then green. The link status LEDs illuminate green, but turn off if there is no link
Ports GE 0/1, GE 0/2, GE 0/3, and GE 0/4		LEDs illuminate if a link is present and established.
As a general rule, an LED illuminates green for items that you installed. If the SM and MM LEDs on the rear panel of the Secure Router 4134 do not illuminate green, refer to the LEDs on the modules to identify issues.		

3. The logon prompt appears on the console screen.

Configuring the Secure Router 4134 for remote access

You must connect a local terminal and log on to the Secure Router 4134 to initially configure the system.

Connecting a terminal for local access

You use the console port to initially configure the system. The following figure shows the location of the console port on the rear panel of the Secure Router 4134.

Figure 6
Connecting a terminal to the Secure Router 4134 console port

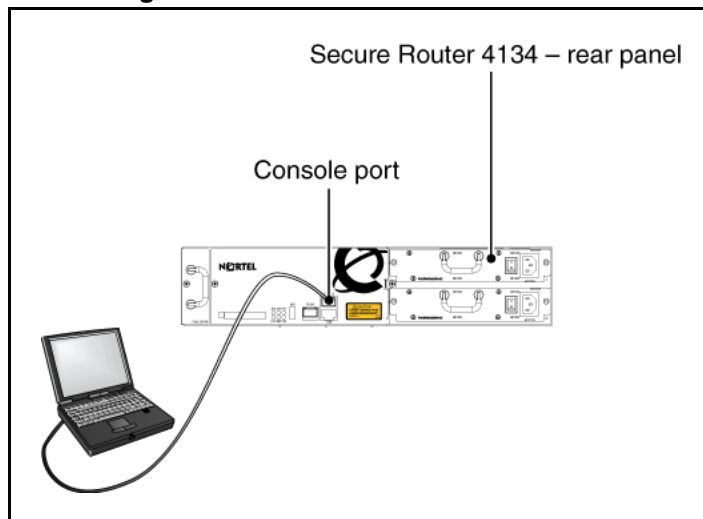

To access the command line interface (CLI) using the rear panel console port, connect a terminal or a workstation that runs terminal emulation software to the Secure Router 4134 using the console cable that ships with the unit.

Prerequisites

- Ensure you have the supplied console cable.
- Ensure you have the supplied female DB-9 to RJ-45 adapter if you require it for connection to your terminal or PC.
- Ensure you have the Secure Router 4134 securely installed in the equipment rack.
- Ensure you have powered up the terminal or PC.

Procedure steps

Step	Action
1	Set the terminal protocol as follows: <ul style="list-style-type: none">a 9600 baudb 8 data bitsc 1 stop bitd no paritye flow control: None
2	Insert the male RJ-45 connector in the console port on the rear panel of the Secure Router 4134.
3	Connect the female DB-9 to RJ-45 adapter to the opposite end of the console cable, if necessary.
4	Insert the RJ-45 or female DB-9 connector (dependent on your equipment) in a terminal or PC.
5	Power up the Secure Router 4134.

--End--

Establishing remote access

The first time you log on to the Secure Router 4134 CLI, you perform initial configuration such as the following:

1. Configure the IP address for the management port.
2. Configure the next hop (gateway IP address).
3. Verify a successful connection.
4. Enable remote access.
You can enable SSH or Telnet for remote connections.

The following procedure uses Ethernet port 0/0 (on the rear of the Secure Router 4134) for the management port. You can also use port 0/1 or port 0/2 on the front panel of the Secure Router 4134 for management purposes. Ethernet port 0/0 is a 10/100 Base-T port. Ethernet ports 0/1 and 0/2 are 10/100/1000 Base-T ports.

ATTENTION

You cannot enable the management port on the rear of the Secure Router 4134 (Ethernet 0/0) if you have a Packetized Voice Module (PVM) installed (this is related to hardware design). Ensure you use Ethernet 0/1, 0/2, 0/3, or 0/4 for management if you use a PVM in the router.

Procedure steps

Step	Action
1	To log on to the Secure Router 4134 CLI for the first time, enter the default user name and password: <code>login: admin</code> <code>password: setup</code>
2	To access configuration mode, enter: <code>configure terminal</code>
3	To select the management port for remote access, enter: <code>interface ethernet 0/0</code>
4	To configure the management port for remote access, enter: <code>ip address <ipaddr> <netmask></code>
5	To configure the speed and mode of the port, enter: <code>speed <10 100 1000 auto> mode <full_duplex half_duplex></code>
6	To exit interface configuration mode, enter: <code>exit</code>
7	To configure the gateway IP address, enter: <code>ip route <ipaddr/netmask> <gateway ipaddr></code>
8	To verify the next hop connection, enter: <code>ping <next-hop ipaddr></code> Ensure the Secure Router 4134 returns a message that indicates the next hop IP address is active.
9	To enable the Telnet server services, enter: <code>telnet_server</code>

--End--

Using SSH for remote access

You can enable an SSH connection for remote access.

Procedure steps

Step	Action
1	To access configuration mode, enter: <code>configure terminal</code>
2	To access the SSH key generation subtree, enter: <code>ssh_keygen</code>
3	To generate the DSA key, enter: <code>generate dsa</code>
4	To generate the RSA key, enter: <code>generate rsa</code>
5	To exit the SSH key generation subtree, enter: <code>exit</code>
6	To enable the SSH connection, enter: <code>ssh_server</code> <code>enable</code>
7	To save the configuration, enter: <code>save local</code>

--End--

You can now access and configure the Secure Router 4134 remotely.

For additional system configuration, see *Nortel Secure Router 4134 — Commissioning* (NN47263-302). To configure features on your Secure Router 4134, see *Nortel Secure Router 4134 — Documentation Roadmap* (NN47263-103) for a list of Nortel Secure Router 4134 documents and information about the Release 10.1 features.

Changing the default administrator password

Nortel recommends that you change the default administrator password for security reasons.

Procedure steps

Step	Action
1	To access password configuration mode, enter: <code>password</code> The Secure Router 4134 prompts you for the current user name.
2	Enter the default user name: <code>admin</code> The Secure Router 4134 prompts you for the old password.

- 3 Enter the default password:
`setup`
The Secure Router 4134 prompts you for the new password.
- 4 Enter your new password.
The Secure Router 4134 prompts you to verify the new password.
- 5 Re-enter your new password.
A message appears that confirms that the password is changed.

--End--

Appendix

Environmental requirements

The Secure Router 4134 must operate within the specified tolerance limits shown in [Table 4 "Environmental requirements for the Secure Router 4134"](#) (page 61).

ATTENTION

Install the Secure Router 4134 in a restricted-access location. Limit access to the Nortel Secure Router 4134 to authorized service personnel only. Ensure you allow 2 to 3 feet (0.61 to 0.91 m) of additional clearance around the Secure Router 4134 for access to the cable connectors on the front and rear panels. For more information on hardware specifications, installation, and clearance requirements for the Secure Router 4134, see *Nortel Secure Router 4134 Installation — Chassis* (NN47263-300).



WARNING

Do not install the Secure Router 4134 near a standing or running water source or in a high-humidity environment.



WARNING

Warnung

Installieren Sie den Secure Router 4134 nicht in der Nähe von stehenden oder fließenden Gewässern oder in einem Gebiet mit sehr hoher Feuchtigkeit.

Table 4
Environmental requirements for the Secure Router 4134

Parameter	Range
Operating temperature	0 to 40 C
Short-term temperature	–40 C to 70 C
Operating altitude	0–11 800 ft (0–3600 m)
Storage altitude	0–35 000 ft (0–11 000 m)
Operating humidity	0 to 90% R.H. (noncondensing)

Table 4
Environmental requirements for the Secure Router 4134 (cont'd.)

Parameter	Range
Storage humidity	0 to 95% R.H. (noncondensing)
Vibration	Packaging and shipping – ISTA 2A Office Vibration – GR-63-CORE Issue 3, Section 4.4.2 and 5.4.2
Acoustic noise	GR-63-CORE Issue 3, section 4.6 and 5.6

Appendix

Translations of safety messages

Class A device caution statement

**CAUTION**

This device is a Class A product. Operation of this equipment in a residential area is likely to cause harmful interference, in which case users will be required to take whatever measures may be necessary to correct the interference at their own expense.

**CAUTION
ACHTUNG**

Dies ist ein Gerät der Klasse A. Bei Einsatz des Geräts in Wohngebieten kann es Störungen des Radio- und Fernsehempfangs verursachen. In diesem Fall muss der Benutzer alle notwendigen Maßnahmen ergreifen, die möglicherweise nötig sind, um die Störungen auf eigene Rechnung zu beheben.

**CAUTION
PRECAUCIÓN**

Este es un producto clase A. El uso de este equipo en áreas residenciales puede causar interferencias nocivas, en cuyo caso, se requerirá que los usuarios tomen cualquier medida necesaria para corregir la interferencia por cuenta propia.

**CAUTION
ATTENTION**

Le périphérique est un produit de Classe A. Le fonctionnement de cet équipement dans une zone résidentielle risque de causer des interférences nuisibles, auquel cas l'utilisateur devra y remédier à ses propres frais.



**CAUTION
CUIDADO**

Este dispositivo é um produto Classe A. Operar este equipamento em uma área residencial provavelmente causará interferência prejudicial; neste caso, espera-se que os usuários tomem as medidas necessárias para corrigir a interferência por sua própria conta.



**CAUTION
ATTENZIONE**

Questo dispositivo è un prodotto di Classe A. Il funzionamento di questo apparecchio in aree residenziali potrebbe causare interferenze dannose, nel cui caso agli utenti verrà richiesto di adottare tutte le misure necessarie per porre rimedio alle interferenze a proprie spese.

注意：この機器は、クラスAの製品です。国内の環境で、この機器は電波障害を引き起こす恐れがあります。この場合、ユーザは適切な対策を講じる必要があります。

注意：本设备属于A类设备。在居住环境中，本设备可能会造成无线电干扰。在这种情况下，用户可能需要采取适当的措施。

警告：该设备是A类产品。在住宅区内使用该设备可能会产生射频干扰，此时用户应采取相应的措施。

Qualified service personnel warning statement



WARNING

Only qualified service personnel must perform installation. Read and follow all warning notices and instructions marked on the product or included in the documentation.



**WARNING
WARNUNG**

Nur qualifiziertes Wartungspersonal darf die Installation vornehmen. Lesen und befolgen Sie die Warnungshinweise und Anweisungen, die auf dem Produkt gekennzeichnet oder in der Dokumentation enthalten sind.

**WARNING
AVISO**

Apenas profissionais de atendimento técnico qualificados devem realizar a instalação. Leia e siga todos os avisos e instruções destacados no produto ou que façam parte da documentação.

**WARNING
AVERTISSEMENT**

L'installation doit être effectuée exclusivement par un personnel qualifié. Lisez et conformez-vous à tous les avis et instructions d'avertissement indiqués sur le produit ou dans la documentation.

**WARNING
ADVERTENCIA**

Sólo el personal de servicio calificado podrá realizar la instalación. Lea y siga todas las instrucciones y advertencias marcadas en el producto o incluidas en la documentación.

**WARNING
AVISO**

Apenas profissionais de atendimento técnico qualificados devem realizar a instalação. Leia e siga todos os avisos e instruções destacados no produto ou que façam parte da documentação.

**WARNING
AVVISO**

L'installazione deve essere eseguita esclusivamente da personale qualificato. Leggere e seguire tutti gli avvisi e le istruzioni presenti sul prodotto o inclusi nella documentazione.

Overcurrent warning statement**WARNING**

The Secure Router 4134 relies on the building's installation for overcurrent protection. Ensure that a fuse or circuit breaker no larger than 120 V AC, 15 A U.S. (240 V AC, 10 A international) is used on the phase conductors.



**WARNING
WARNUNG**

Die Nutzung dieses Produkts setzt einen Überstromschutz am Gebäude voraus. Stellen Sie sicher, dass eine Sicherung oder ein Trennschalter mit höchstens 120 V Wechselstrom, 15 A USA (240 V Wechselstrom, 10 A international) bei den Außenleitern verwendet wird.



**WARNING
ADVERTENCIA**

Este producto depende de la instalación del edificio en cuanto a la protección de sobrecorriente. Asegúrese de utilizar un fusible o disyuntor no mayor a 120 V AC, 15 A EE.UU. (240 V AC, 10 A internacional) en los conductores de fase.



**WARNING
AVERTISSEMENT**

Ce produit repose sur les installations de protection contre la surtension du bâtiment. Assurez-vous de ne pas utiliser un fusible ou un disjoncteur de plus de 120 Vca, 15 A U.S. (240 Vca, 10 A internationaux) sur les conducteurs de phase.



**WARNING
AVISO**

Este produto depende de o prédio possuir em sua instalação elétrica a proteção contra corrente excessiva. Certifique-se de que sejam usados um fusível ou interruptor que não ultrapassem os 120 V AC, 15 A EUA (240 V AC, 10 A em outros países) nos condutores de fase.



**WARNING
AVVISO**

Questo prodotto fa affidamento sull'installazione all'interno dell'edificio di un sistema di protezione per gli eccessi di corrente. Accertarsi che un fusibile o un interruttore di circuito non superiore a 120 V CA, 15 A U.S.A. (240 V CA, 10 A internazionale) sia utilizzato sui conduttori di fase.

Cover plate warning statement



CAUTION

If you do not install a module in the slot, be sure to keep the metal cover plate in place over the slot. Removing the cover plate impedes airflow and proper cooling of the unit.



**CAUTION
ACHTUNG**

Wenn Sie in kein Modul in diesem Steckplatz installieren, stellen Sie sicher, dass sich die Abdeckplatte aus Metall weiterhin über dem Steckplatz befindet. Wenn die Metallplatte entfernt wird, behindert dies den Luftstrom und eine angemessene Kühlung der Einheit.



**CAUTION
ATTENTION**

Si vous n'installez pas de module dans le connecteur, veillez à laisser le panneau de protection métallique en place sur le connecteur. Le retrait du panneau de protection entrave la circulation de l'air et empêche un refroidissement correct de l'unité.



**CAUTION
PRECAUCIÓN**

Si no instala un módulo en la ranura, asegúrese de mantener la placa de cubierta de metal en su lugar sobre la ranura. Quitar la placa de cubierta impide la circulación de aire y el enfriamiento adecuado de la unidad.



**CAUTION
CUIDADO**

Caso você não vá instalar um módulo no slot, mantenha a tampa de metal no lugar. A remoção da tampa impede correntes de ar e o resfriamento adequado à unidade.



**CAUTION
ATTENZIONE**

Se nello slot non viene installato un modulo, accertarsi di mantenere la copertura in metallo posizionata sullo slot. La rimozione della copertura in metallo ostruisce il flusso d'aria e il raffreddamento appropriato dell'unità.

Power cord warning statement



DANGER

Use only power cords that have a grounding path. Without a proper ground, a person who touches the switch is in danger of receiving an electrical shock. Lack of a grounding path to the switch may result in excessive emissions.



DANGER
GEFAHR

Verwenden Sie nur Netzkabel mit Erdungspfad. Ohne einen angemessenen Untergrund besteht für die Person, die den Schalter berührt, die Gefahr eines Stromschlags. Das Fehlen eines Erdungspfads beim Schalter führt möglicherweise zu überhöhten Emissionen.



DANGER
DANGER

Utilisez uniquement des cordons d'alimentation possédant un conducteur de terre. En l'absence d'un conducteur de terre, une personne touchant le commutateur pourrait recevoir un choc électrique. L'absence de conducteur de terre au commutateur peut provoquer des émissions excessives.



DANGER
PELIGRO

Utilice sólo cables de corriente que tengan puesta a tierra. Sin una puesta a tierra adecuada, una persona que tocara el interruptor estaría en peligro de recibir una descarga eléctrica. La falta de una puesta a tierra en el interruptor podría causar emisiones excesivas.



DANGER
PERIGO

Use apenas cabos de alimentação que tenham ligação à terra. Sem um aterramento adequado, uma pessoa que toque no switch corre o risco de receber um choque elétrico. A ausência de aterramento para o switch pode resultar em excesso de emissões.



DANGER
PERICOLO

Utilizzare esclusivamente cavi di alimentazione dotati di un percorso per il collegamento a terra. Senza un appropriato sistema di messa a terra, le persone che vengono a contatto con l'interruttore corrono il rischio di ricevere scosse elettriche. L'assenza di un percorso per il collegamento a terra dell'interruttore può causare un eccesso di emissioni.

Nortel Secure Router 4134

Quick Start

Copyright © 2007, 2008 Nortel Networks
All Rights Reserved.

Release: 10.1
Publication: NN47263-100
Document status: Standard
Document revision: 02.01
Document release date: 18 February 2008

To provide feedback or to report a problem in this document, go to www.nortel.com/documentfeedback.

www.nortel.com

The information in this document is subject to change without notice. The statements, configurations, technical data, and recommendations in this document are believed to be accurate and reliable, but are presented without express or implied warranty. Users must take full responsibility for their applications of any products specified in this document.

This document is protected by copyright laws and international treaties. All information, copyrights and any other intellectual property rights contained in this document are the property of Nortel Networks. Except as expressly authorized in writing by Nortel Networks, the holder is granted no rights to use the information contained herein and this document shall not be published, copied, produced or reproduced, modified, translated, compiled, distributed, displayed or transmitted, in whole or part, in any form or media.

Sourced in Canada, the United States of America, and India.

*Nortel, the Nortel logo, and the Globemark are trademarks of Nortel Networks.

All other trademarks are the property of their respective owners.

ATTENTION: Before unpacking, installing, or using the Secure Router 4134, ensure you read the section about regulatory information and general safety precautions in the first chapter of this guide.

