

FEATURES

- Requires no external components
- Measures temperatures from -55°C to $+125^{\circ}\text{C}$ in 0.5°C increments. Fahrenheit equivalent is -67°F to 257°F in 0.9°F increments
- Temperature is read as a 9-bit value
- Converts temperature to digital word in 200 ms, typical
- Thermostatic settings are user-definable and non-volatile
- Internal 50 ohm resistor provides self heating
- Data is read from/written via a 3-wire serial interface (CLK, DQ, RST)
- Applications include thermostatic controls, industrial systems, consumer products, thermometers, or any thermally sensitive system
- 16-pin SOIC package

DESCRIPTION

The DS1620R self-heating temperature sensor provides 9-bit temperature readings which indicate the temperature of the device. The internal 50 ohm resistor acts as the self-heating element. Predictable self-heating characteristics allow users to model temperature rise of active components in their system, allowing monitoring of airflow and other thermal management parameters. With three thermal alarm outputs, the DS1620R can also act as a thermostat. T_{HIGH} is driven high if the DS1620R's temperature exceeds a user defined temperature TH. T_{LOW} is driven high if the

PIN ASSIGNMENT

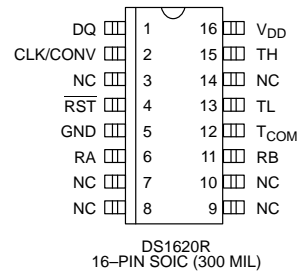

PIN DESCRIPTION

DQ	– 3-Wire Input/Output
CLK/CONV	– 3-Wire Clock Input and Standalone Convert Input
RST	– 3-Wire Reset Input
GND	– Ground
RA	– Connection to internal 50Ω resistor
RB	– Connection to internal 50Ω resistor
T_{HIGH}	– High Temperature Trigger
T_{LOW}	– Low Temperature Trigger
T_{COM}	– High/Low Combination Trigger
VDD	– Power Supply Voltage (+5V)

DS1620R's temperature falls below a user defined temperature TL. T_{COM} is driven high when the temperature exceeds TH, and stays high until the temperature falls below that of TL.

User defined temperature settings are stored in non-volatile memory, so parts may be programmed prior to insertion in a system, as well as used in stand-alone applications without a CPU. Temperature settings, and temperature readings are all communicated to/from the DS1620R over a simple 3-wire interface.

OPERATION – READING TEMPERATURE

The DS1620R measures temperatures through the use of an on-board proprietary temperature measurement technique. The temperature reading is provided in a 9-bit, two's complement reading. Table 1 describes the exact relationship of output data to measured temperature. The data is transmitted serially through the 3-wire serial interface, LSB first. The DS1620R can measure temperature over the range of -55°C to +125°C in 0.5°C increments. For Fahrenheit usage, a lookup table or conversion factor must be used.

Since data is transmitted over the 3-wire bus LSB first, temperature data may be written to/read from the DS1620R as either a 9-bit word (asserting $\overline{\text{RST}}$ after the 9th (MSB) bit), or as two transfers of 8-bit words, with the most significant 7 bits being ignored or set to zero, as illustrated in Table 1.

Note that temperature is represented in the DS1620R in terms of a $1/2^\circ\text{C}$ LSB, yielding the following 9-bit format:

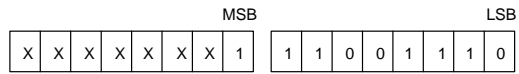

T = -25°C

TEMPERATURE/DATA RELATIONSHIPS Table 1

TEMP	DIGITAL OUTPUT (Binary)	DIGITAL OUTPUT (Hex)
+125°C	00000000 11111010	00FA
+25°C	00000000 00110010	0032h
$1/2^\circ\text{C}$	00000000 00000001	0001h
0°C	00000000 00000000	0000h
$-1/2^\circ\text{C}$	00000001 11111111	01FFh
-25°C	00000001 11001110	01CEh
-55°C	00000001 10010010	0192h

DS1620R FUNCTIONAL BLOCK DIAGRAM Figure 1

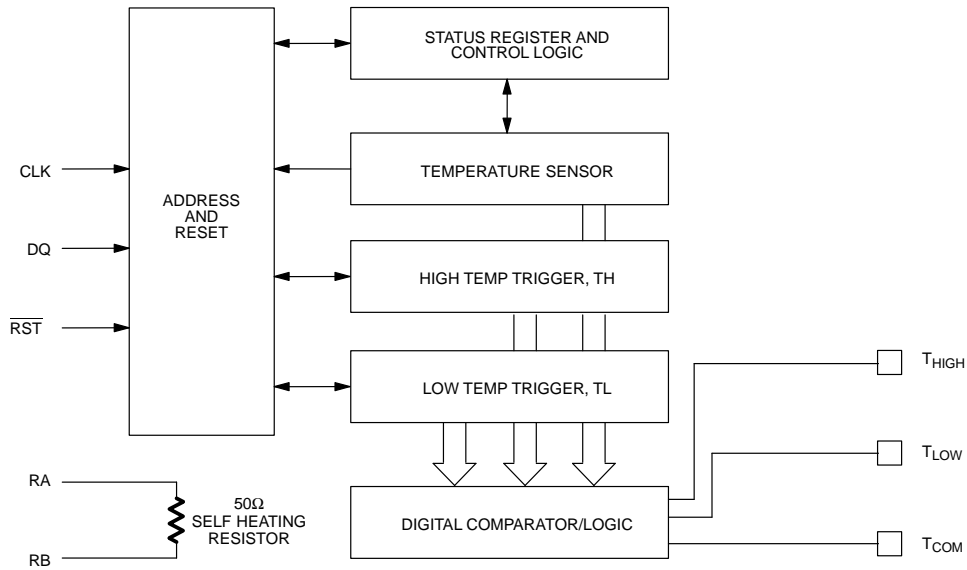

DETAILED PIN DESCRIPTION Table 2

PIN	SYMBOL	DESCRIPTION
1	DQ	Data Input/Output pin for 3–wire communication port.
2	CLK/ $\overline{\text{CONV}}$	Clock input pin for 3–wire communication port. When the DS1620 is used in a standalone application with no 3–wire port, this pin can be used as a convert pin. Temperature conversion will begin on the falling edge of CONV.
3	NC	No internal connection
4	$\overline{\text{RST}}$	Reset input pin for 3–wire communication port.
5	GND	Ground pin
6	RA	Connection to one side of internal 50 ohm resistor
7	NC	No internal connection
8	NC	No internal connection
9	NC	No internal connection
10	NC	No internal connectio.
11	RB	Connection to one side of internal 50 ohm resistor
12	T _{COM}	High/Low Combination Trigger. Goes high when temperature exceeds TH; will reset to low when temperature falls below TL.
13	T _{LOW}	Low Temperature Trigger. Goes high when temperature falls below TL.
14	NC	No internal connection
15	T _{HIGH}	High Temperature Trigger. Goes high when temperature exceeds TH.
16	V _{DD}	Supply Voltage. 5V input power pin.

OPERATION – THERMOSTAT CONTROLS

Three thermally triggered outputs, T_{HIGH}, T_{LOW}, and T_{COM}, are provided to allow the DS1620R to be used as a thermostat, as shown in Figure 2. When the DS1620R's temperature meets or exceeds the value stored in the high temperature trip register, the output T_{HIGH} becomes active (high) and remains active until the DS1620R's measured temperature becomes less than the stored value in the high temperature register, TH. The T_{HIGH} output can be used to indicate that a high temperature tolerance boundary has been met or exceeded, or as part of a closed loop system can be used to activate a cooling system and to deactivate it when the system temperature returns to tolerance.

The T_{LOW} output functions similarly to the T_{HIGH} output. When the DS1620R's measured temperature equals or

falls below the value stored in the low temperature register, the T_{LOW} output becomes active. T_{LOW} remains active until the DS1620R's temperature becomes greater than the value stored in the low temperature register, TL. The T_{LOW} output can be used to indicate that a low temperature tolerance boundary has been met or exceeded, or as part of a closed loop system, can be used to activate a heating system and to deactivate it when the system temperature returns to tolerance.

The T_{COM} output goes high when the measured temperature exceeds TH, and will stay high until the temperature falls below TL. In this way, any amount of hysteresis may be obtained.

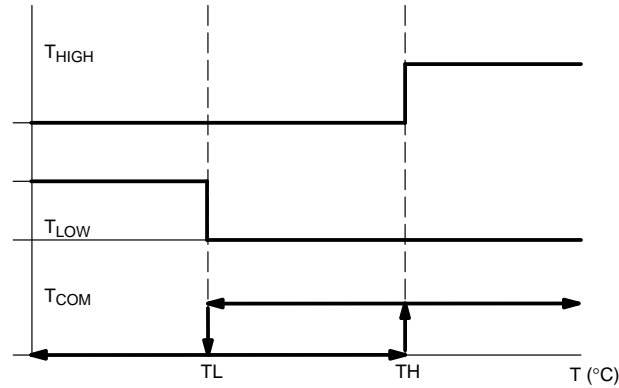
THERMOSTAT OUTPUT OPERATION Figure 2**OPERATION AND CONTROL**

The DS1620R must have temperature settings resident in the TH and TL registers for thermostatic operation. A configuration/status register is also used to determine the method of operation that the DS1620R will use in a particular application, as well as indicating the status of the temperature conversion operation.

The configuration register is defined as follows:

CONFIGURATION/STATUS REGISTER

DONE	THF	TLF	NVB	1	0	CPU	1SHOT
------	-----	-----	-----	---	---	-----	-------

where

X = Don't Care

DONE = Conversion Done bit. 1=Conversion complete, 0=Conversion in progress. In continuous conversion mode, the bit will always be 0. In one-shot mode, this bit should be checked prior to attempting to read the temperature to assure that the conversion is complete.

THF = Temperature High Flag. This bit will be set to 1 when the temperature is greater than or equal to the value of TH. It will remain 1 until reset by writing 0 into this location or by removing power from the device. This feature provides a method of determining if the DS1620 has ever been subjected to temperatures above TH while power has been applied

TLF = Temperature Low Flag. This bit will be set to 1 when the temperature is less than or equal to the value of TL. It will remain 1 until reset by writing 0 into this location or by removing power from the device. This feature provides a method of determining if the DS1620 has ever been subjected to temperatures below TL while power has been applied.

NVB = Nonvolatile Memory Busy Flag. This bit will be a 1 while a write to E2 memory is in progress; 0=nonvolatile memory not busy. A write to E2 memory typically takes 10 ms, but may take up to 50 ms at high temperatures.

CPU = CPU use bit. If CPU=0, the CLK/CONV pin acts as a conversion start control, when RST is low. If CPU is 1, the DS1620 will be used with a CPU communicating to it over the 3-wire port, and the operation of the CLK/CONV pin is as a normal clock in concert with DQ and RST. This bit is stored in nonvolatile E2 memory, capable of at least 50,000 writes.

1SHOT = One-Shot Mode. If 1SHOT is 1, the DS1620 will perform one temperature conversion upon reception of the Start Convert T protocol. If 1SHOT is 0, the DS1620 will continuously perform temperature conversion. This bit is stored in nonvolatile E2 memory, capable of at least 50,000 writes.

For typical thermostat operation, the DS1620R will operate in continuous mode. However, for applications where only one reading is needed at certain times, and to conserve power, the one-shot mode may be used. Note that the thermostat outputs (T_{HIGH} , T_{LOW} , T_{COM}) will remain in the state they were in after the last valid temperature conversion cycle when operating in one-shot mode.

OPERATION IN STAND-ALONE MODE

In applications where the DS1620R is used as a simple thermostat, no CPU is required save for programming the temperature limits. Since the temperature limits are nonvolatile, the DS1620R may be programmed prior to insertion in the system. In order to facilitate operation without a CPU, the CLK/CONV pin (pin 2) may be used to initiate conversions. Note that the CPU bit must be set to 0 in the configuration register to use this mode of operation.

To use the CLK/CONV pin to initiate conversions, RST must be low and CLK/CONV must be high. If CLK/CONV is driven low and then brought high in less than 10 ms, one temperature conversion will be performed and then the DS1620 will return to an idle state. If CLK/CONV is driven low and remains low, continuous conversions will take place until CLK/CONV is brought high again. With the CPU bit set to 0, the CLK/CONV will override the 1-shot bit if it is equal to 1. This means that even if the part is set for one-shot mode, driving CLK/CONV low will initiate conversions..

INTERNAL RESISTOR

The internal 50 ohm resistor is connected between pins RA and RB. A typical application will use this resistor connected between 5V and ground, providing a 500mW power dissipation in the resistor. In still air, this will cause an approximately 40°C temperature rise in the DS1620R. Under other airflow conditions, this temperature rise will be different, giving some indication as to how much heat is conducted away from the device by the airflow. The actual temperature rise and thermostat settings for use in a particular system will therefore be dictated by the system's design and protection requirements, and must be characterized by the user.

Because the DS1620R measures the actual die temperature of the device, its measurement range is from -55°C to +125°C; however, since the internal resistor is causing a temperature rise in the device, the entire DS1620R is rated for operation in ambient temperatures of -40°C to +85°C only.

3-WIRE COMMUNICATIONS

The 3-wire bus is comprised of three signals. These are the \overline{RST} (reset) signal, the CLK (clock) signal, and the DQ (data) signal. All data transfers are initiated by driving the \overline{RST} input high. Driving the \overline{RST} input low terminates communication. (See Figures 3 and 4.)

A clock cycle is a sequence of a falling edge followed by a rising edge. For data inputs, the data must be valid during the rising edge of a clock cycle. Command bits and data bits are output on the falling edge of the clock, and remain valid through the rising edge.

When reading data from the DS1620R, the DQ pin goes to a high impedance state while the clock is high. Taking \overline{RST} low will terminate any communication and cause the DQ pin to go to a high impedance state.

Data over the 3-wire interface is communicated LSB first.

The command set for the 3-wire interface as shown in Table 3 is as follows:

Read Temperature [AAh]

This command reads the contents of the register which contains the last temperature conversion result. The next nine clock cycles will output the contents of this register.

Write TH [01h]

This command writes to the TH (HIGH TEMPERATURE) register. After issuing this command, the next 9 clock cycles clock in the 9-bit temperature limit which will set the threshold for operation of the T_{HIGH} output.

Write TL [02h]

This command writes to the TL (LOW TEMPERATURE) register. After issuing this command, the next nine clock cycles clock in the 9-bit temperature limit which will set the threshold for operation of the T_{LOW} output.

Read TH [A1h]

This command reads the value of the TH (HIGH TEMPERATURE) register. After issuing this command, the next nine clock cycles clock out the 9-bit temperature limit which sets the threshold for operation of the T_{HIGH} output.

Read TL [A2h]

This command reads the value of the TL (LOW TEMPERATURE) register. After issuing this command, the next nine clock cycles clock out the 9-bit temperature limit which sets the threshold for operation of the T_{LOW} output.

Start Convert T [EEh]

This command begins a temperature conversion. No further data is required. In one-shot mode, the temperature conversion will be performed and then the DS1620R will remain idle. In continuous mode, this command will initiate continuous conversions.

Stop Convert T [22h]

This command stops temperature conversion. No further data is required. This command may be used to halt

a DS1620R in continuous conversion mode. After issuing this command, the current temperature measurement will be completed, and then the DS1620R will remain idle until a Start Convert T is issued to resume continuous operation.

Write Config [0Ch]

This command writes to the configuration register. After issuing this command, the next eight clock cycles clock in the value of the configuration register.

Read Config [ACh]

This command reads the value in the configuration register. After issuing this command, the next eight clock cycles output the value of the configuration register.

DS1620R COMMAND SET Table 3

INSTRUCTION	DESCRIPTION	PROTOCOL	3-WIRE BUS DATA AFTER ISSUING PROTOCOL	NOTES
TEMPERATURE CONVERSION COMMANDS				
Read Temperature	Reads last converted temperature value from temperature register.	AAh	<read data>	
Start Convert T	Initiates temperature conversion.	EEh	idle	1
Stop Convert T	Halts temperature conversion.	22h	idle	1
THERMOSTAT COMMANDS				
Write TH	Writes high temperature limit value into TH register.	01h	<write data>	2
Write TL	Writes low temperature limit value into TL register.	02h	<write data>	2
Read TH	Reads stored value of high temperature limit from TH register.	A1h	<read data>	2
Read TL	Reads stored value of low temperature limit from TL register.	A2h	<read data>	2
Write Config	Writes configuration data to configuration register.	0Ch	<write data>	2
Read Config	Reads configuration data from configuration register.	ACh	<read data>	2

NOTES:

1. In continuous conversion mode, a Stop Convert T command will halt continuous conversion. To restart, the Start Convert T command must be issued. In one-shot mode, a Start Convert T command must be issued for every temperature reading desired.
2. Writing to the E^2 typically requires 10 ms at room temperature. After issuing a write command, no further writes should be requested for at least 10 ms.

FUNCTION EXAMPLE

Example: CPU sets up DS1620 for continuous conversion and thermostatic function.

CPU MODE	DS1620 MODE (3-WIRE)	DATA (LSB FIRST)	COMMENTS
TX	RX	Raise \overline{RST}	CPU raises \overline{RST} to initiate transfer.
TX	RX	0Ch	CPU issues Write Config command.
TX	RX	02h	CPU sets DS1620R up for continuous conversion.
TX	RX	Toggle \overline{RST}	CPU drops \overline{RST} , then brings it high again to initiate new transfer.
TX	RX	01h	CPU issues Write TH command.
TX	RX	0050h	CPU sends data for TH limit of +40°C.
TX	RX	Toggle \overline{RST}	CPU drops \overline{RST} , then brings it high again to initiate new transfer.
TX	RX	02h	CPU issues Write TL command.
TX	RX	0014h	CPU sends data for TL limit of +10°C.
TX	RX	Toggle \overline{RST}	CPU drops \overline{RST} , then brings it high again to initiate new transfer.
TX	RX	A1h	CPU issues Read TH command.
RX	TX	0050h	DS1620R sends back stored value of TH for CPU to verify.
TX	RX	Toggle \overline{RST}	CPU drops \overline{RST} , then brings it high again to initiate new transfer.
TX	RX	A2h	CPU issues Read TL command.
RX	TX	0014h	DS1620R sends back stored value of TL for CPU to verify.
TX	RX	Toggle \overline{RST}	CPU drops \overline{RST} , then brings it high again to initiate new transfer.
TX	RX	EEh	CPU issues Start Convert T command.
TX	RX	Drop \overline{RST}	CPU brings \overline{RST} low, ending transfer

ABSOLUTE MAXIMUM RATINGS*

Voltage on Any Pin Relative to Ground	-0.5V to +7.0V
Operating Temperature	-55°C to +125°C
Storage Temperature	-55°C to +125°C
Soldering Temperature	260°C for 10 seconds

* This is a stress rating only and functional operation of the device at these or any other conditions above those indicated in the operation sections of this specification is not implied. Exposure to absolute maximum rating conditions for extended periods of time may affect reliability.

RECOMMENDED DC OPERATING CONDITIONS

PARAMETER	SYMBOL	MIN	TYP	MAX	UNITS	NOTES
Supply	V_{DD}	4.5	5.0	5.5	V	1
Logic 1	V_{IH}	2.0		$V_{CC}+0.3$	V	1
Logic 0	V_{IL}	-0.3		+0.8	V	1

DC ELECTRICAL CHARACTERISTICS(-55°C to +125°C; $V_{DD}=4.5V$ to 5.5V)

PARAMETER	SYMBOL	CONDITION	MIN	MAX	UNITS	NOTES
Thermometer Error	T_{ERR}	0°C to +70°C -55°C to +0°C and 70°C to 125°C		$\pm 1/2$	°C	10
Long-term Stability		105°C, 1000 hours		± 0.1	°C	
Logic 0 Output	V_{OL}			0.4	V	3
Logic 1 Output	V_{OH}		2.4		V	2
Input Resistance	R_I	DQ, \overline{RST} to GND, CLK to V_{DD}	1 1		M Ω M Ω	
Active Supply Current	I_{CC}	0°C to +70°C		1	mA	4, 5
Standby Supply Current	I_{STBY}	0°C to +70°C		1	μA	4, 5

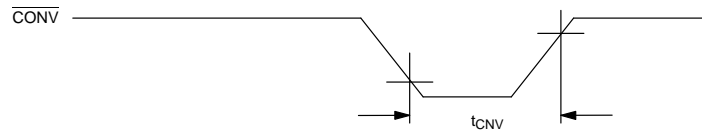
SINGLE CONVERT TIMING DIAGRAM (STAND-ALONE MODE)

AC ELECTRICAL CHARACTERISTICS(-55°C to +125°C; $V_{DD}=4.5V$ to 5.5V)

PARAMETER	SYMBOL	MIN	TYP	MAX	UNITS	NOTES
Temperature Conversion Time	T_{TC}		200	500	ms	
Data to CLK Setup	t_{DC}	35			ns	6
CLK to Data Hold	t_{CDH}	40			ns	6
CLK to Data Delay	t_{CDD}			100	ns	6, 7, 8
CLK Low Time	t_{CL}	285			ns	6
CLK High Time	t_{CH}	285			ns	6
CLK Frequency	f_{CLK}	DC		1.75	MHz	6
CLK Rise and Fall	t_R, t_F			500	ns	
\overline{RST} to CLK Setup	t_{CC}	100			ns	6
CLK to \overline{RST} Hold	t_{CCH}	40			ns	6
\overline{RST} Inactive Time	t_{CWH}	125			ns	6, 9
CLK High to I/O High-Z	t_{CDZ}			50	ns	6
\overline{RST} Low to I/O High-Z	t_{RDZ}			50	ns	6
Convert Pulse Width	t_{CNV}	250 ns		500 ms		
NV Write Cycle Time	t_{WR}		10	50	ms	

AC ELECTRICAL CHARACTERISTICS(-55°C to +125°C; $V_{DD}=4.5V$ to 5.5V)

PARAMETER	SYMBOL	MIN	TYP	MAX	UNITS	NOTES
Input Capacitance	C_I		5		pF	
I/O Capacitance	$C_{I/O}$		10		pF	

NOTES:

- All voltages are referenced to ground.
- Logic one voltages are specified at a source current of 1 mA.
- Logic zero voltages are specified at a sink current of 4 mA.
- I_{CC} specified with DQ pin open.
- I_{CC} specified with V_{CC} at 5.0V and $\overline{RST}=\text{GND}$.
- Measured at $V_{IH} = 2.0V$ or $V_{IL} = 0.8V$.
- Measured at $V_{OH} = 2.4V$ or $V_{OL} = 0.4V$.
- Load capacitance = 50 pF.
- t_{CWH} must be 10 ms minimum following any write command that involves the E² memory.
- See typical curve for specification limits outside 0°C to 70°C range. Thermometer error reflects sensor accuracy as tested during calibration.
- Power rating derates linearly from 70°C to 150°C.

READ DATA TRANSFER Figure 3

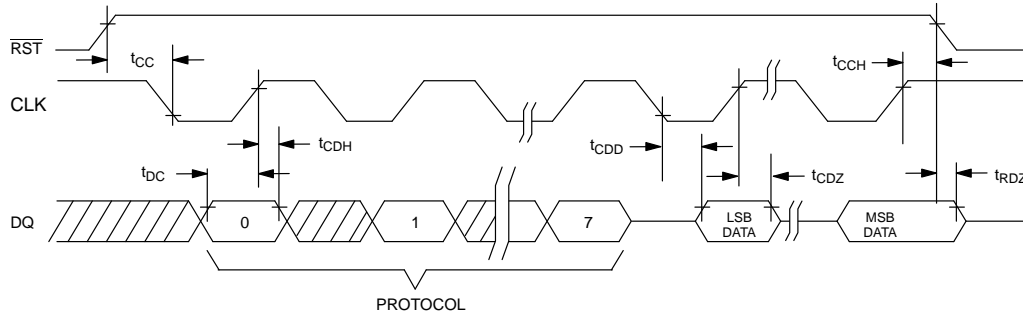

WRITE DATA TRANSFER Figure 4

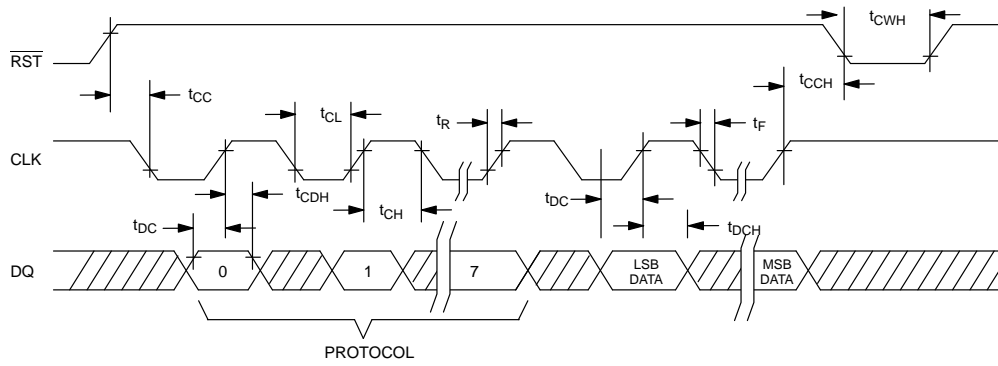

NOTE: t_{cl} , t_{ch} , t_r , and t_f apply to both read and write data transfer.

TYPICAL PERFORMANCE CURVE

DS1620R DIGITAL THERMOMETER AND THERMOSTAT
TEMPERATURE READING ERROR

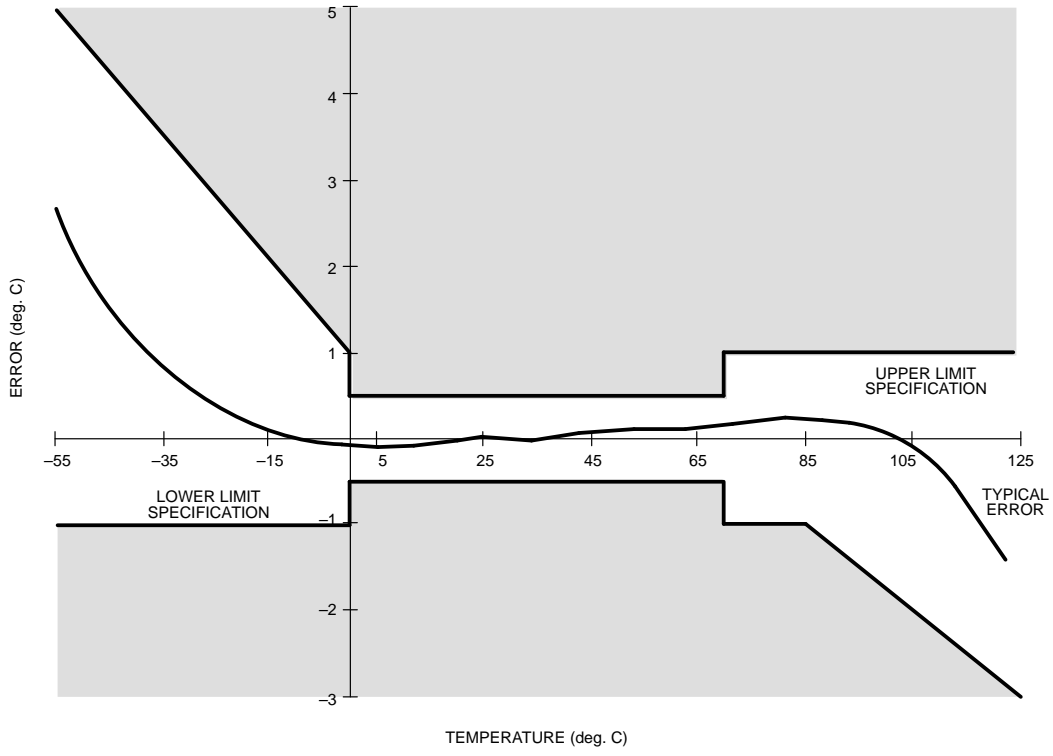

DATA SHEET REVISION SUMMARY

The following represent the key differences between 02/14/97 and 05/29/97 version of the DS1620R data sheet. Please review this summary carefully.

1. Remove "Preliminary". Ds1620R is at full Quality.

