

DALLAS

SEMICONDUCTOR

DS1630Y/AB

Partitionable 256K NV SRAM

FEATURES

- 10 years minimum data retention in the absence of external power
- Data is automatically protected during power loss
- Directly replaces 32K x 8 volatile static RAM or EEPROM
- Write protects selected blocks of memory when programmed
- Unlimited write cycles
- Low-power CMOS
- Read and write access times as fast as 70 ns
- Lithium energy source is electrically disconnected to retain freshness until power is applied for the first time
- Full $\pm 10\%$ V_{CC} operating range (DS1630Y)
- Optional $\pm 5\%$ V_{CC} operating range (DS1630AB)
- Optional industrial temperature range of -40°C to $+85^{\circ}\text{C}$, designated IND
- JEDEC standard 28-pin DIP package
- Low Profile Module (LPM) package
 - Fits into standard 68-pin PLCC surface mountable socket
 - 255 mils package height
 - Power Fail Output (PFO) warns system of impending V_{CC} power failure

PIN ASSIGNMENT

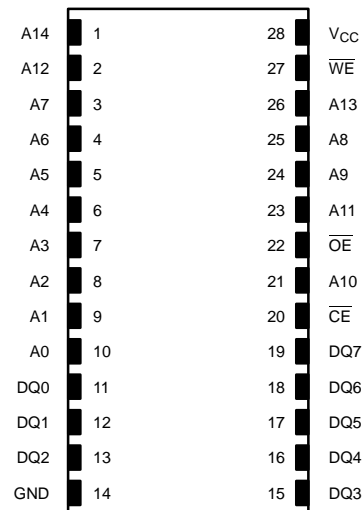

28-PIN ENCAPSULATED PACKAGE
740 MIL EXTENDED

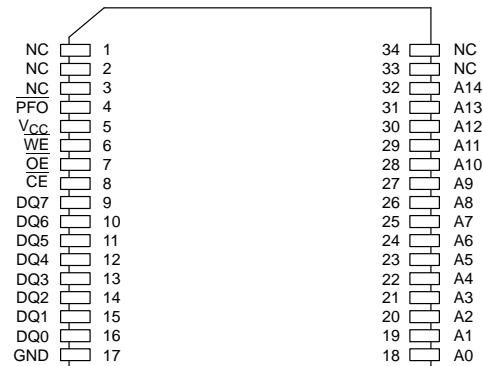

34-PIN LOW PROFILE MODULE (LPM)

PIN DESCRIPTION

A0 – A14	– Address Inputs
DQ0 – DQ7	– Data In/Data Out
$\overline{\text{CE}}$	– Chip Enable
$\overline{\text{WE}}$	– Write Enable
$\overline{\text{OE}}$	– Output Enable
$\overline{\text{PFO}}$	– Power Fail Output (LPM only)
V_{CC}	– Power (+5V)
GND	– Ground
NC	– No Connect

DESCRIPTION

The DS1630 256K Nonvolatile SRAMs are 262,144-bit, fully static, nonvolatile SRAMs organized as 32,768 words by 8 bits. Each NV SRAM has a self-contained lithium energy source and control circuitry which constantly monitors V_{CC} for an out-of-tolerance condition. When such a condition occurs, the lithium energy source is automatically switched on and write protection is unconditionally enabled to prevent data corruption. In addition, the device has the ability to unconditionally write protect blocks of memory so that inadvertent write cycles do not corrupt programs and important data. There is no limit on the number of write cycles that can be executed and no additional support circuitry is required for microprocessor interfacing. DIP-package DS1630 devices can be used in place of existing 32K x 8 SRAMs directly conforming to the popular byte-wide 28-pin DIP standard. The DIP devices also match the pinout of 28256 EEPROMs, allowing direct substitution while enhancing performance. DS1630 devices in the Low Profile Module package are specifically designed for surface mount applications. DS1630 LPM devices also have an additional pin, a Power Fail Output, that can be used to warn a system of impending V_{CC} power failure.

READ MODE

The DS1630 devices execute a read cycle whenever $\overline{\text{WE}}$ (Write Enable) is inactive (high) and $\overline{\text{CE}}$ (Chip Enable) and $\overline{\text{OE}}$ (Output Enable) are active (low). The unique address specified by the 15 address inputs ($A_0 - A_{14}$) defines which of the 32,768 bytes of data is to be

accessed. Valid data will be available to the eight data output drivers within t_{ACC} (Access Time) after the last address input signal is stable, providing that $\overline{\text{CE}}$ and $\overline{\text{OE}}$ access times are also satisfied. If $\overline{\text{OE}}$ and $\overline{\text{CE}}$ access times are not satisfied, then data access must be measured from the later occurring signal ($\overline{\text{CE}}$ or $\overline{\text{OE}}$) and the limiting parameter is either t_{CO} for $\overline{\text{CE}}$ or t_{OE} for $\overline{\text{OE}}$ rather than address access.

WRITE MODE

The DS1630 devices execute a write cycle whenever the $\overline{\text{WE}}$ and $\overline{\text{CE}}$ signals are in the active (low) state after address inputs are stable. The latter occurring falling edge of $\overline{\text{CE}}$ or $\overline{\text{WE}}$ will determine the start of the write cycle. The write cycle is terminated by the earlier rising edge of $\overline{\text{CE}}$ or $\overline{\text{WE}}$. All address inputs must be kept valid throughout the write cycle. $\overline{\text{WE}}$ must return to the high state for a minimum recovery time (t_{WR}) before another cycle can be initiated. The $\overline{\text{OE}}$ control signal should be kept inactive (high) during write cycles to avoid bus contention. However, if the output drivers are enabled ($\overline{\text{CE}}$ and $\overline{\text{OE}}$ active) then $\overline{\text{WE}}$ will disable the outputs in t_{ODW} from its falling edge.

DATA RETENTION MODE

The DS1630AB provides full functional capability for V_{CC} greater than 4.75 volts and write protects by 4.5 volts. The DS1630Y provides full functional capability for V_{CC} greater than 4.5 volts and write protects by 4.25 volts. Data is maintained in the absence of V_{CC} without any additional support circuitry. The nonvolatile static RAMs constantly monitor V_{CC} . Should the supply voltage decay, the NV SRAMs automatically write protect themselves, all inputs become “don’t care,” and all outputs become high impedance. As V_{CC} falls below approximately 3.0 volts, a power switching circuit connects the lithium energy source to RAM to retain data. During power-up, when V_{CC} rises above approximately 3.0 volts, the power switching circuit connects external V_{CC} to RAM and disconnects the lithium energy source. Normal RAM operation can resume after V_{CC} exceeds 4.75 volts for the DS1630AB and 4.5 volts for the DS1630Y.

FRESHNESS SEAL

Each DS1630 is shipped from Dallas Semiconductor with its lithium energy source disconnected, guaranteeing full energy capacity. When V_{CC} is first applied at a level greater than V_{TP} , the lithium energy source is enabled for battery backup operation.

PARTITION PROGRAMMING MODE

The register controlling the partitioning logic is selected by recognition of a specific binary pattern which is sent on address lines A11 – A14. These address lines are the four upper order address lines being sent to RAM. The pattern is sent by 20 consecutive read cycles with the exact pattern as shown in Table 1. Pattern matching must be accomplished using read cycles; any write cycles will reset the pattern matching circuitry. If this pattern is matched perfectly, then the 21st through 24th

read cycles will load the partition register. Since there are 16 protectable partitions, the size of each partition is 32K/16 or 2K x 8. Each partition is represented by one of the 16 bits contained in the 21st through 24th read cycles as defined by A11 through A14 and shown in Table 2. A logical 1 in a bit location write protects the corresponding partition. A logical 0 in a bit location disables write protection. For example, if during the pattern match sequence bit 22 on address pin A12 was a 1, this would cause the partition register location for partition 5 to be set to a 1. This in turn would cause the DS1630 devices to internally inhibit \overline{WE} for all write accesses where A14 A13 A12 A11=0101. Note that while programming the partition register, data which is being accessed from the RAM should be ignored, since the purpose of the 24 read cycles is to program the partition register, not to access data from RAM.

PATTERN MATCH TO WRITE PARTITION REGISTER Table 1

	1	2	3	4	5	6	7	8	9	10	11	12	13	14	15	16	17	18	19	20	21	22	23	24
A11	1	0	1	1	1	1	0	0	1	1	1	0	0	0	0	0	1	1	0	1	X	X	X	X
A12	1	1	1	1	1	0	0	1	1	1	0	0	1	0	1	1	0	0	0	0	X	X	X	X
A13	1	1	1	1	0	0	1	1	1	0	0	1	0	1	0	1	0	0	0	1	X	X	X	X
A14	1	1	0	0	0	1	1	1	0	0	1	0	0	0	1	0	1	0	0	0	X	X	X	X

FIRST BITS ENTERED

LAST BITS ENTERED

PARTITION REGISTER MAPPING Table 2

Address Pin	Bit number in pattern match sequence	Partition Number	Address State Affected (A ₁₄ A ₁₃ A ₁₂ A ₁₁)
A11	BIT 21	PARTITION 0	0000
A12	BIT 21	PARTITION 1	0001
A13	BIT 21	PARTITION 2	0010
A14	BIT 21	PARTITION 3	0011
A11	BIT 22	PARTITION 4	0100
A12	BIT 22	PARTITION 5	0101
A13	BIT 22	PARTITION 6	0110
A14	BIT 22	PARTITION 7	0111
A11	BIT 23	PARTITION 8	1000
A12	BIT 23	PARTITION 9	1001
A13	BIT 23	PARTITION 10	1010
A14	BIT 23	PARTITION 11	1011
A11	BIT 24	PARTITION 12	1100
A12	BIT 24	PARTITION 13	1101
A13	BIT 24	PARTITION 14	1110
A14	BIT 24	PARTITION 15	1111

ABSOLUTE MAXIMUM RATINGS*

Voltage on Any Pin Relative to Ground	-0.5V to +7.0V
Operating Temperature	0°C to 70°C, -40°C to +85°C for IND parts
Storage Temperature	-40°C to +70°C, -40°C to +85°C for IND parts
Soldering Temperature	260°C for 10 seconds

* This is a stress rating only and functional operation of the device at these or any other conditions above those indicated in the operation sections of this specification is not implied. Exposure to absolute maximum rating conditions for extended periods of time may affect reliability.

RECOMMENDED DC OPERATING CONDITIONS(t_A: See Note 10)

PARAMETER	SYMBOL	MIN	TYP	MAX	UNITS	NOTES
DS1630 Power Supply Voltage	V _{CC}	4.5	5.0	5.5	V	
DS1630AB Power Supply Voltage	V _{CC}	4.75	5.0	5.25	V	
Logic 1	V _{IH}	2.2		V _{CC}	V	
Logic 0	V _{IL}	0.0		+0.8	V	

DC ELECTRICAL CHARACTERISTICS(V_{CC}=5V ± 10% for DS1630Y)
(t_A: See Note 10) (V_{CC}=5V ± 5% for DS1630AB)

PARAMETER	SYMBOL	MIN	TYP	MAX	UNITS	NOTES
Input Leakage Current	I _{IL}	-1.0		+1.0	μA	
I/O Leakage Current C _E ≥ V _{IH} ≤ V _{CC}	I _{IO}	-1.0		+1.0	μA	
Output Current @ 2.4V	I _{OH}	-1.0			mA	
Output Current @ 0.4V	I _{OL}	2.0			mA	14
Standby Current C _E = 2.2V	I _{CCS1}		5.0	10.0	mA	
Standby Current C _E = V _{CC} - 0.5V	I _{CCS2}		3.0	5.0	mA	
Operating Current	I _{CCO1}			85	mA	
Write Protection Voltage (DS1630Y)	V _{TP}	4.25	4.37	4.5	V	
Write Protection Voltage (DS1630AB)	V _{TP}	4.50	4.62	4.75	V	

CAPACITANCE(t_A = 25°C)

PARAMETER	SYMBOL	MIN	TYP	MAX	UNITS	NOTES
Input Capacitance	C _{IN}		5	10	pF	
Input/Output Capacitance	C _{I/O}		5	10	pF	

(V_{CC}=5V ± 5% for DS1630AB)**AC ELECTRICAL CHARACTERISTICS**(t_A: See Note 10) (V_{CC}=5V ± 10% for DS1630Y)

PARAMETER	SYMBOL	DS1630Y-70 DS1630AB-70		DS1630Y-85 DS1630AB-85		UNITS	NOTES
		MIN	MAX	MIN	MAX		
Read Cycle Time	t _{RC}	70		85		ns	
Access Time	t _{ACC}		70		85	ns	
\overline{OE} to Output Valid	t _{OE}		35		45	ns	
\overline{CE} to Output Valid	t _{CO}		70		85	ns	
\overline{OE} or \overline{CE} to Output Valid	t _{COE}	5		5		ns	5
Output High Z from Deselection	t _{OD}		25		30	ns	5
Output Hold from Address Change	t _{OH}	5		5		ns	
Write Cycle Time	t _{WC}	70		85		ns	
Write Pulse Width	t _{WP}	55		65		ns	3
Address Setup Time	t _{AW}	0		0		ns	
Write Recovery Time	t _{WR1} t _{WR2}	10 10		10 10		ns ns	12 13
Output High Z from \overline{WE}	t _{ODW}		25		30	ns	5
Output Active from \overline{WE}	t _{OEW}	5		5		ns	5
Data Setup Time	t _{DS}	30		35		ns	4
Data Hold Time	t _{DH1} t _{DH2}	5 5		5 5		ns ns	12 13

PARAMETER	SYMBOL	DS1630Y-100 DS1630AB-100		DS1630Y-120 DS1630AB-120		UNITS	NOTES
		MIN	MAX	MIN	MAX		
Read Cycle Time	t _{RC}	100		120		ns	
Access Time	t _{ACC}		100		120	ns	
\overline{OE} to Output Valid	t _{OE}		50		60	ns	
\overline{CE} to Output Valid	t _{CO}		100		120	ns	
\overline{OE} or \overline{CE} to Output Valid	t _{COE}	5		5		ns	5
Output High Z from Deselection	t _{OD}		35		35	ns	5
Output Hold from Address Change	t _{OH}	5		5		ns	
Write Cycle Time	t _{WC}	100		120		ns	
Write Pulse Width	t _{WP}	75		90		ns	3
Address Setup Time	t _{AW}	0		0		ns	
Write Recovery Time	t _{WR1} t _{WR2}	10 10		10 10		ns ns	12 13
Output High Z from \overline{WE}	t _{ODW}		35		35	ns	5
Output Active from \overline{WE}	t _{OEW}	5		5		ns	5
Data Setup Time	t _{DS}	40		50		ns	4
Data Hold Time	t _{DH1} t _{DH2}	5 5		5 5		ns ns	12 13

AC ELECTRICAL CHARACTERISTICS

(t_A : See Note 10) ($V_{CCI}=4.50V$ to $5.50V$)*

PARAMETER	SYMBOL	MIN	TYP	MAX	UNITS	NOTES
Address Setup	t_{AS}	0			ns	
Address Hold	t_{AH}	50			ns	
Read Recovery	t_{RR}	10			ns	
\overline{CE} Pulse Width	t_{CW}	75			ns	

*For loading partition register

TIMING DIAGRAM: LOADING PARTITION REGISTER

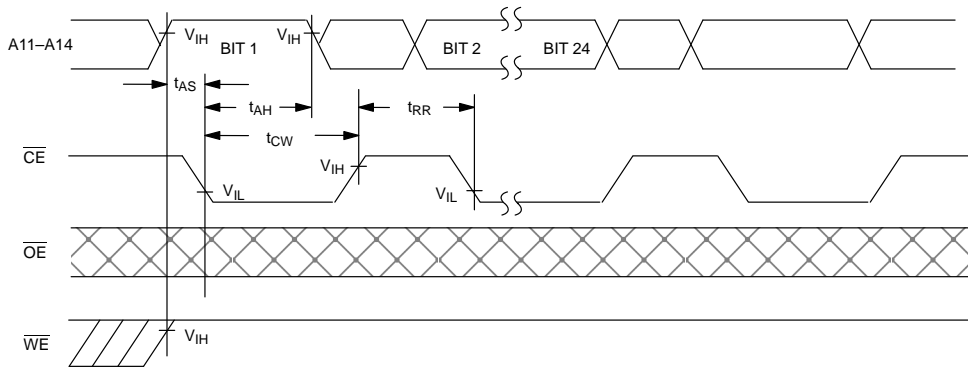

READ CYCLE

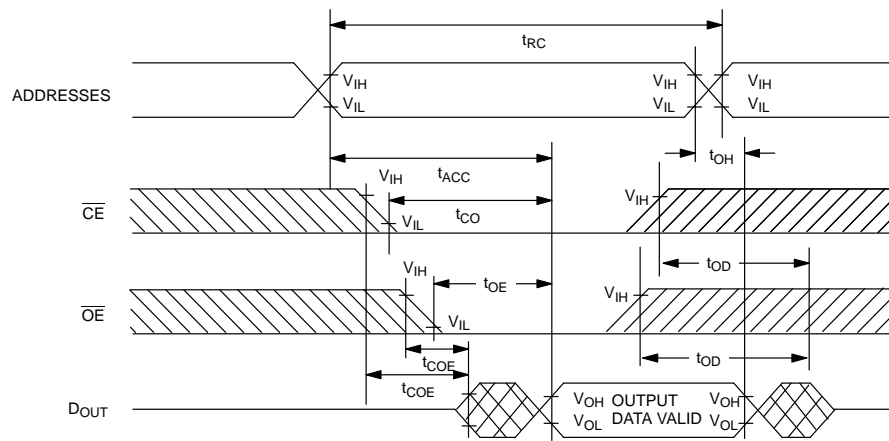

SEE NOTE 1

WRITE CYCLE 1

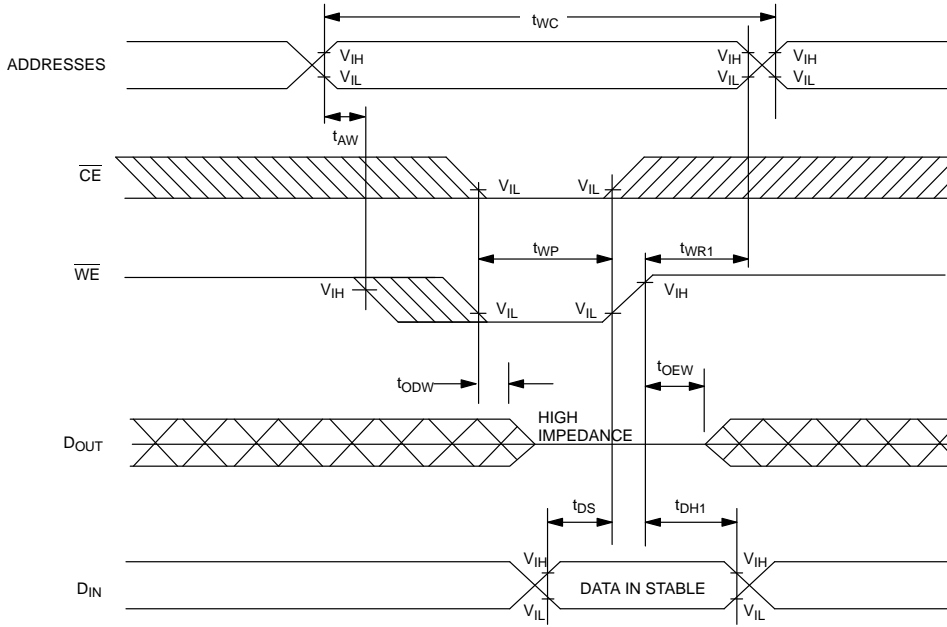

SEE NOTES 2, 3, 4, 6, 7, 8 AND 12

WRITE CYCLE 2

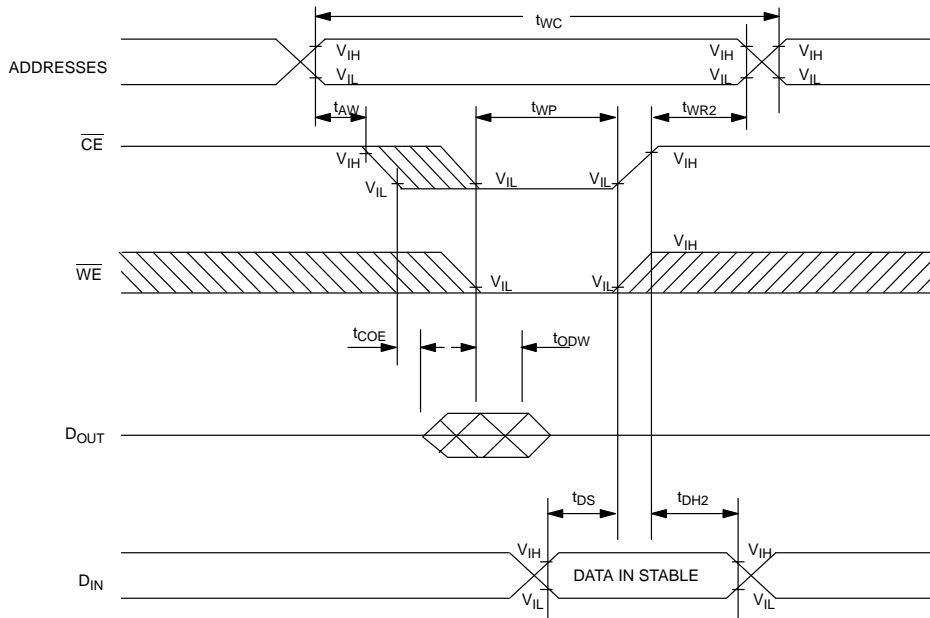

SEE NOTES 2, 3, 4, 6, 7, 8 AND 13

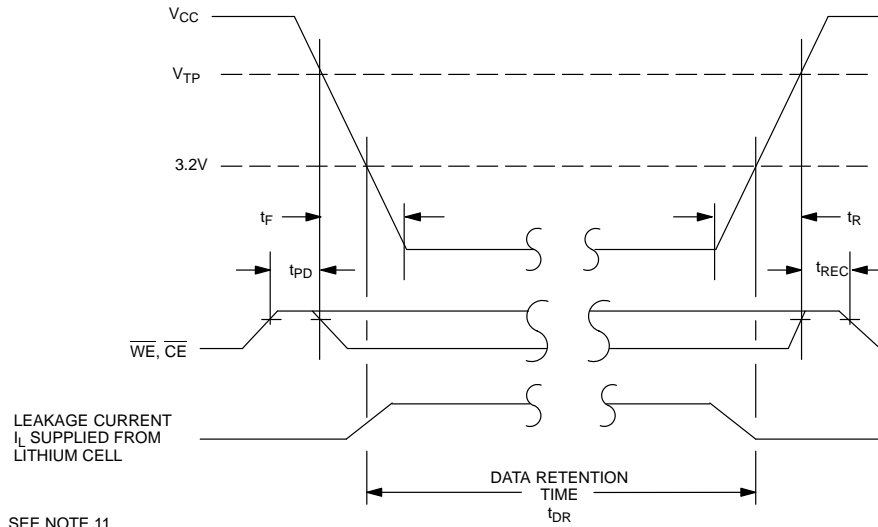
POWER-DOWN/POWER-UP CONDITION**POWER-DOWN/POWER-UP TIMING** $(t_A: \text{See Note 10})$

PARAMETER	SYMBOL	MIN	TYP	MAX	UNITS	NOTES
\overline{CE} , \overline{WE} at V_{IH} before Power-Down	t_{PD}	0			μs	11
V_{CC} slew from V_{TP} to 0V	t_F	300			μs	
V_{CC} slew from 0V to V_{TP}	t_R	0			μs	
\overline{CE} , \overline{WE} at V_{IH} after Power-Up	t_{REC}	25			ms	

 $(t_A = 25^\circ\text{C})$

PARAMETER	SYMBOL	MIN	TYP	MAX	UNITS	NOTES
Expected Data Retention Time	t_{DR}	10			years	9

WARNING:

Under no circumstance are negative undershoots, of any amplitude, allowed when device is in battery backup mode.

NOTES:

- \overline{WE} is high for a read cycle.
- $\overline{OE} = V_{IH}$ or V_{IL} . If $\overline{OE} = V_{IH}$ during write cycle, the output buffers remain in a high impedance state.
- t_{WP} is specified as the logical AND of \overline{CE} and \overline{WE} . t_{WP} is measured from the latter of \overline{CE} or \overline{WE} going low to the earlier of \overline{CE} or \overline{WE} going high.
- t_{DS} is measured from the earlier of \overline{CE} or \overline{WE} going high.
- These parameters are sampled with a 5 pF load and are not 100% tested.

6. If the \overline{CE} low transition occurs simultaneously with or later than the \overline{WE} low transition in Write Cycle 1, the output buffers remain in a high impedance state during this period.
7. If the \overline{CE} high transition occurs prior to or simultaneously with the \overline{WE} high transition in Write Cycle 1, the output buffers remain in a high impedance state during this period.
8. If \overline{WE} is low or the \overline{WE} low transition occurs prior to or simultaneously with the \overline{CE} low transition, the output buffers remain in a high impedance state during this period.
9. Each DS1630 has a built-in switch that disconnects the lithium source until V_{CC} is first applied by the user. The expected t_{DR} is defined as accumulative time in the absence of V_{CC} starting from the time power is first applied by the user.
10. All AC and DC electrical characteristics are valid over the full operating temperature range. For commercial products, this range is 0°C to 70°C for industrial products (IND), this range is -40°C to +85°C.
11. In a power down condition the voltage on any pin may not exceed the voltage on V_{CC} .
12. t_{WR1} , t_{DH1} are measured from \overline{WE} going high.
13. t_{WR2} , t_{DH2} are measured from \overline{CE} going high.
14. The power fail output signal (\overline{PFO}) is driven active ($V_{OL}=0.4V$) when the V_{CC} trip point occurs. While active, the \overline{PFO} pin can sink 4 mA and will maintain a maximum output voltage of 0.4 volts. When inactive, the voltage output of \overline{PFO} is 2.4 volts minimum and will source a current of 1 mA. This signal is only present on the LPM package variations.
15. DS1630 modules are recognized by Underwriters Laboratory (U.L.®) under file E99151(R).

DC TEST CONDITIONS

Outputs Open
 t Cycle = 200 ns
 All voltages are referenced to ground

AC TEST CONDITIONS

Output Load: 100 pF + 1TTL Gate
 Input Pulse Levels: 0 – 3.0V
 Timing Measurement Reference Levels
 Input: 1.5V
 Output: 1.5V
 Input pulse Rise and Fall Times: 5 ns

ORDERING INFORMATION

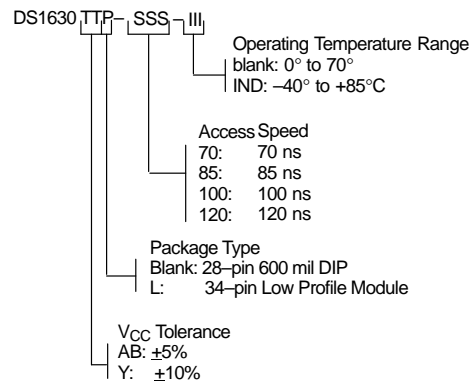

DS1630Y/AB NONVOLATILE SRAM, 28-PIN 740 MIL EXTENDED MODULE

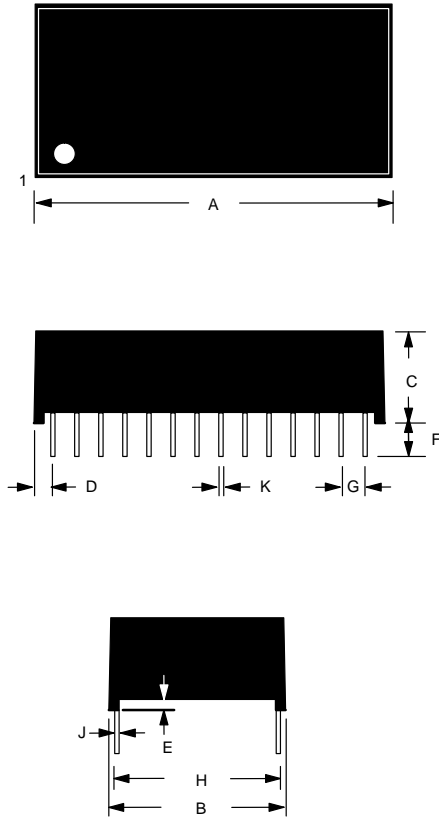

PKG	28-PIN		
	DIM	MIN	MAX
A	IN. MM	1.480 37.60	1.500 38.10
B	IN. MM	0.720 18.29	0.740 18.80
C	IN. MM	0.355 9.02	0.375 9.52
D	IN. MM	0.080 2.03	0.110 2.79
E	IN. MM	0.015 0.38	0.025 0.63
F	IN. MM	0.120 3.05	0.160 4.06
G	IN. MM	0.090 2.29	0.110 2.79
H	IN. MM	0.590 14.99	0.630 16.00
J	IN. MM	0.008 0.20	0.012 0.30
K	IN. MM	0.015 0.38	0.021 0.53

DS1630Y/AB 34-PIN LOW PROFILE MODULE (LPM)

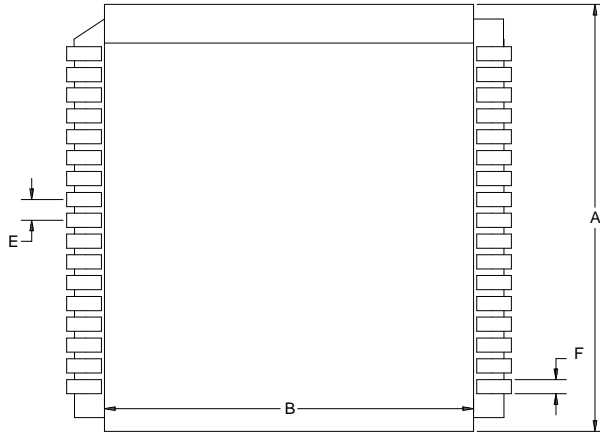

PKG	INCHES	
	MIN	MAX
A	0.955	0.980
B	0.840	0.855
C	0.230	0.250
D	0.975	0.995
E	0.047	0.053
F	0.015	0.025

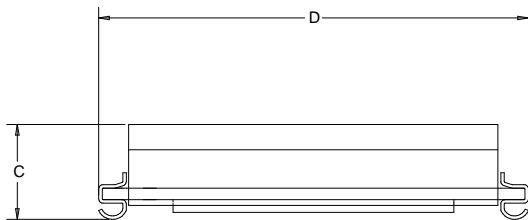

Dallas Semiconductor Low Profile Modules must be inserted into 68-pin PLCC sockets for proper operation. Direct surface-mounting of these products by reflow soldering will destroy internal lithium batteries.

For recommended PLCC sockets, contact the Dallas Semiconductor factory.