

## FEATURES

- Direct-to-digital temperature sensor requires no external components or user calibration
- Two fan speed sensors
- Monitors 6 power supply voltages
- 8-bit DAC for fan speed control
- Intrusion detect for security (detects when chassis lid has been removed, even if power is off)
- Remote system reset
- System interrupt availability on all monitored functions (temperature, voltages, fan speed, chassis intrusion)
- 2-wire interface with 2-bit addressability
- Integrated NAND TREE for board level testability
- Wide power supply range ( $2.8V \leq V_{DD} \leq 5.75V$ )
- High integration in a small 24-pin 173 mil TSSOP
- Applications include monitoring of personal computers or any microprocessor-based system

## DESCRIPTION

The DS1780 is a highly integrated system instrumentation monitor ideal for use in personal computers, or any microprocessor-based system. It monitors ambient temperature, six power supply voltages, and the speed of two fans. Fan speed can also be controlled with the use of an internal 8-bit DAC. All measurements are internally converted to a digital format for easy processing by the CPU.

## PIN ASSIGNMENT

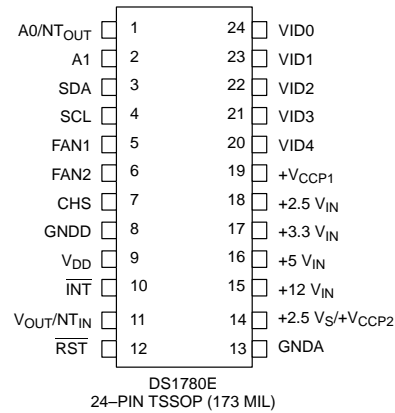

## PIN DESCRIPTION

A0/NT <sub>OUT</sub>	Address input / NAND TREE output
A1	Address input
SDA	2-Wire Serial Data Input/Output
SCL	2-Wire Serial Clock
FAN <sub>x</sub>	Tachometer inputs
CHS	Chassis Intrusion Detector input
GNDD	Digital ground
V <sub>DD</sub>	Power Supply Voltage (2.8V to 5.75V)
$\overline{INT}$	Hardware Interrupt output
V <sub>OUT</sub> /NT <sub>IN</sub>	DAC output / NAND TREE input
RST	Remote system reset
GNDA	Analog ground
+xxV <sub>IN</sub>	Positive voltage inputs
+2.5V <sub>S</sub> /+V <sub>CCP2</sub>	Positive/negative voltage input
VID <sub>x</sub>	Processor voltage supply readout inputs

The DS1780 can be reset to its default power up state via a remote reset function with internal debounce and delay. It features an interrupt that can be programmed to become active should any of the functions the DS1780 is monitoring fall out of spec.

For board level testability, an internal NAND TREE function simplifies the system design. A chassis intrusion input is featured to enhance system security.

Programming and data readout are accessed via a simple 2-wire interface with two-bit addressability. The

DS1780 power supply range of 2.8V to 5.75V allows for monitoring of parameters for 3V or 5V systems. The DS1780 is assembled in a compact 173 mil TSSOP package.

**Detailed Pin Description Table 1.**

PIN	SIGNAL	DIRECTION	DESCRIPTION
1	A0/NT <sub>OUT</sub>	Digital I/O	The lowest order programmable bit of the 2-wire bus address. This pin functions as an output when doing a NAND TREE test.
2	A1	Digital Input	The highest order programmable bit of the 2-wire bus address.
3	SDA	Digital I/O	2-wire bus bi-directional data. Open-drain output.
4	SCL	Digital Input	2-wire bus synchronous clock.
5	FAN1	Digital Input	0 to V <sub>DD</sub> amplitude fan tachometer input.
6	FAN2	Digital Input	0 to V <sub>DD</sub> amplitude fan tachometer input.
7	CHS	Digital I/O	An active high input from an external circuit, which latches a Chassis Intrusion event. This line can go high without any clamping action regardless of the powered state of the DS1780. The DS1780 provides an internal open drain on this line, controlled by Bit 6 of Configuration Register, to provide a minimum 20 ms reset of this signal.
8	GNDD	GROUND	Internally connected to all digital circuitry.
9	V <sub>DD</sub>	POWER	+3.3V or +5V V <sub>DD</sub> power. Bypass with the parallel combination of 10 μF (Electrolytic or Tantalum) and 0.1 μF (ceramic) bypass capacitors.
10	$\overline{\text{INT}}$	Digital Output	Active-low Programmable interrupt output. The output is enabled when Bit 1 of the Configuration Register is set to 1. The default state is disabled.
11	V <sub>OUT</sub> /NT <sub>IN</sub>	Digital Input/ Analog Output	An active-high input that enables NAND Tree board-level connectivity testing. Refer to "NAND Tree Testing" Section. Used as DAC output when NAND Tree is not selected.
12	$\overline{\text{RST}}$	Digital I/O	Master Reset, 5 mA open-drain driver, active low output with at least a 20 ms minimum pulse width. Available when enabled via Bit 4 in Configuration Register. This is a bi-directional I/O pin. It acts as power on RESET input.
13	GNDA	GROUND	Internally connected to all analog circuitry. The ground reference for all analog inputs.
14	+2.5V <sub>S</sub> /+V <sub>CCP2</sub>	Analog Input	Analog input for monitoring -12V or +V <sub>CCP2</sub> . DS1780 will measure voltages on this pin from 0V to 3.6V. An external resistor ladder is required for monitoring a -12V supply (see Figure 1).
15-19	+xxV <sub>IN</sub>	Analog Inputs	A/D inputs for 5 positive voltages.
20-24	VIDx	Digital Inputs	Voltage supply readouts from the processor. These values are read in the VID and VID4 Status Registers.

## OVERVIEW

A block diagram of the DS1780 is shown in Figure 1.

The DS1780 provides 6 analog inputs, an analog output, 5 digital inputs, 2 fan speed inputs, a temperature sensor, and interrupt registers on a single chip, which communicates on a 2-wire serial bus. The DS1780 performs power supply, temperature, and fan monitoring for personal computers.

The analog voltages are divided internally by the DS1780. The inputs are then converted to 8-bit digital words. The analog inputs are intended to be connected to the several power supplies present in a typical computer. Temperature can be converted to an 9-bit two's-complement digital word with a 0.5°C LSB.

The analog output is approximately a 0–1.25V output from an 8-bit D/A converter, which is used to control fan speeds.

Fan inputs measure the period of tachometer pulses from the fans, providing a higher count for lower fan speeds. The fan inputs are digital inputs with an acceptable range of 0 to  $V_{DD}$  volts and a transition level of approximately 1.4 volts. Full-scale fan counts are 255 (8-bit counter) and this represents a stopped or very slow fan. Nominal speeds, based on a count of 153, are programmable from 1100 to 8800 RPM on FAN1 and FAN2. Signal conditioning circuitry is included to accommodate slow rise and fall times.

The DS1780 provides a number of internal registers, as detailed in Table 1. These include:

**Configuration Register:** Provides control and configuration, as well as initialization.

**Interrupt ( $\overline{\text{INT}}$ ) Status Registers:** Two registers to provide status of each Interrupt limit or Interrupt event.

**Interrupt ( $\overline{\text{INT}}$ ) Mask Registers:** Allows masking of individual Interrupt sources, as well as separate masking for the hardware interrupt output.

**Temperature Configuration Register:** The lower 2 bits of this register configure the type of temperature interrupt mode to be used. Bit 7 reflects the lowest bit of the temperature reading.

**VID Register, VID4 Register:** Bits 0–3 of the VID register reflect the status of the VID0–VID3 pins, bit 0 of the VID4 register reflect the status of VID4 pin. These are simply input pins – not processed in any way. In a multi-processor system, these signals will be multiplexed externally from the various processor sources, with the source being controlled by software.

**Value RAM:** The monitoring results and limits for temperature, voltages, and fan counts are all contained in the Value RAM.

When the DS1780 is started, it cycles through each measurement in sequence, and it continuously loops through the sequence approximately once every second. Each measured value is compared to values stored in limit registers. When the measured value violates the programmed limit the DS1780 will set a corresponding System Management Interrupt (SMI) in the Interrupt Status Registers. One hardware interrupt line,  $\overline{\text{INT}}$ , is available to generate an SMI.  $\overline{\text{INT}}$  is fully programmable with masking of each Interrupt source, and masking of the output. In addition, the configuration register has control bits to enable or disable the hardware Interrupts.

A CHS (Chassis Intrusion) digital input is provided. The Chassis Intrusion input is designed to accept an active high signal from an external circuit that latches when the case is removed from the computer; this pin is a dual purpose pin which will be driven low by the DS1780 to reset the external circuit.

DS1780 FUNCTIONAL BLOCK DIAGRAM Figure 1

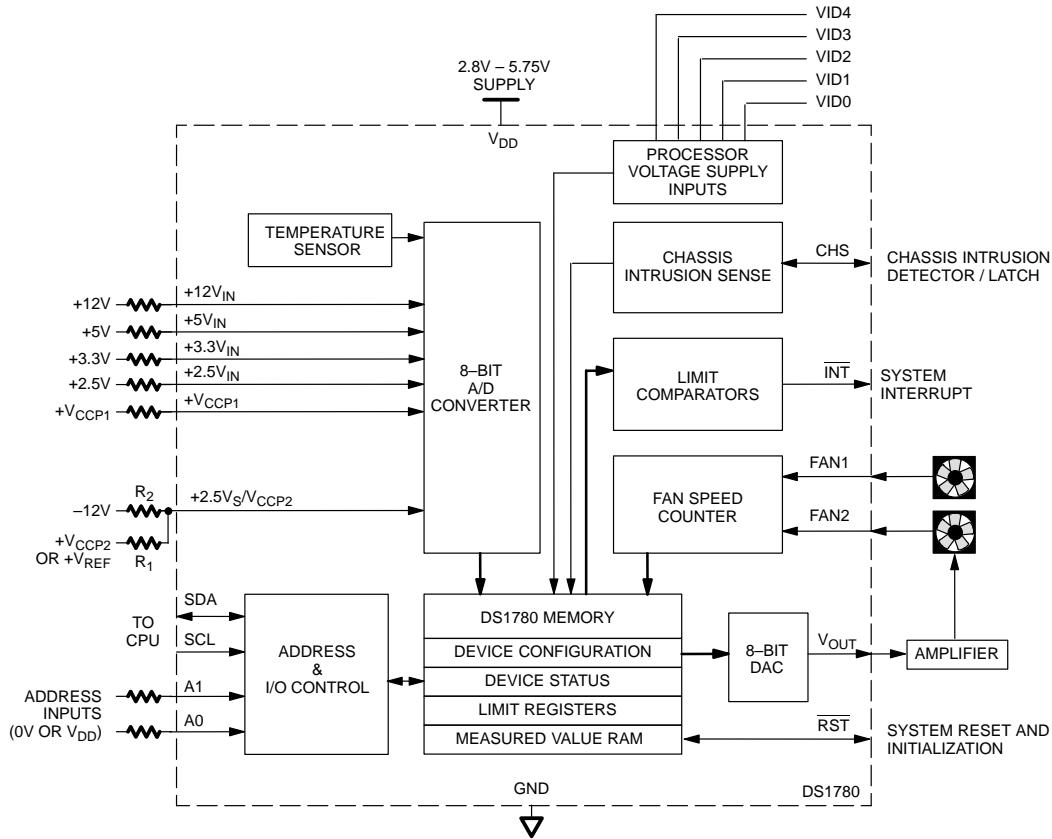

**Note:** R1 and R2 on the  $-12\text{V}$  resistance ladder should be ratioed such that approximately  $+2.5\text{V}$  appears at the input pin (i.e.,  $R1=4\text{k}\Omega$ ,  $R2=23.2\text{k}\Omega$ ). If a second processor voltage needs to be monitored ( $V_{\text{ccp2}}$ ), leave R2 empty, and make R1  $500\Omega$ , with  $V_{\text{ccp2}}$  appearing here.

## 2-WIRE SERIAL DATA BUS

When using the 2-wire bus, a write will always consist of the DS1780 2-wire slave address, followed by the Internal Address Register byte, then the data byte. The Internal Address Register addresses are listed below in Table 2. There are two cases for a read:

1. If the Internal Address Register is known to be at the desired Address, simply read the DS1780 with the 2-wire slave address, followed by the data byte read from the DS1780.

2. If the Internal Address Register value is unknown, write to the DS1780 with the 2-wire slave address, followed by the Internal Address Register byte. Then restart the Serial Communication with a Read consisting of the 2-wire slave address, followed by the data byte read from the DS1780.

The default power-on 2-wire slave address for the DS1780 is  $01011(A1)(A0)$  binary, where  $A0$ – $A1$  reflects the state of the pins defined by the same names. The address can be changed by writing any desired value to the 2-wire Serial Address Register (excluding the 2 LSBs). This communication protocol is depicted in the 2-wire timing diagrams of Figures 2 and 8.

**INTERNAL ADDRESS REGISTER MAP** Table 2

REGISTER	DS1780 INTERNAL HEX ADDRESS	POWER ON VALUE	NOTES
Configuration Register	40h	0000 1000	
Interrupt (INT) Status Register 1	41h	0000 0000	
Interrupt (INT) Status Register 2	42h	0000 0000	
Interrupt (INT) Mask Register 1	43h	0000 0000	
Interrupt (INT) Mask Register 2	44h	0000 0000	
Chassis Intrusion Clear Register	46h	0000 0000	Bit 7 of this register clears Chassis Intrusion. The other bits are reserved.
VID Register	47h	0101 XXXX	The lower 4 bits reflect the state of VID0–VID3 pins.
Serial Address Register	48h	0010 11XY	X Reflects state of A1 and Y Reflects A0 state
VID4 Register	49h	1000 000X	Bit 0 = VID 4. The rest are reserved.
Temperature Configuration Register	4Bh	0000 0001	
Test Register	15h	0000 0000	Do not alter the contents of the register.
Analog output	19h	1111 1111	Full on
Value RAM	20h–3Dh		
Company ID	3Eh	1101 1010	Read only
Stepping	3Fh	0000 0001	Read only

## 2-WIRE SERIAL COMMUNICATION WITH THE DS1780 Figure 2

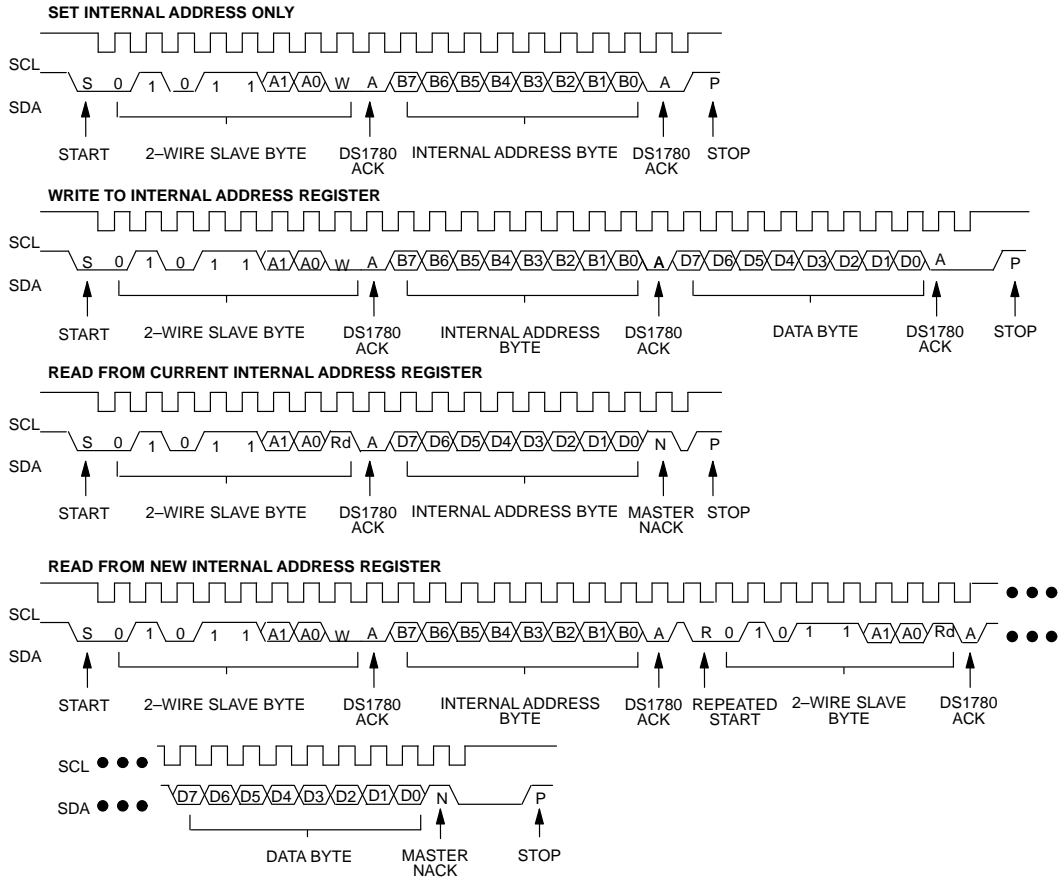

### OPERATION – Power-on

Applying power to the DS1780 causes a reset of several of the registers. Power on conditions of the registers are shown in Table 2 above. Some registers have indeterminate power on values, such as the Limit and RAM registers of the Value RAM page, and these are not shown in the table. Upon power up the ADC is inactive. Writing Limits into the Value RAM should usually be the first action performed after power up. The  $\overline{\text{RST}}$  pin is bi-directional. It forces RESET at power on, but can also be pulled low to force RESET internally.

### OPERATION – Resets

The DS1780 features four distinct resetting functions. Each one has a different effect on register contents and

the state of the  $\overline{\text{RST}}$  output following the event. Each one is explained below:

**Power-on Reset** – On POR, all internal logic is reset, and registers are cleared to their default state (see tables 10.x). Because Value RAM is typically the first area programmed upon power-up, it does not have a defined state upon POR. Also, on POR, the  $\overline{\text{RST}}$  output will be pulled to an active low state for 20 ms (minimum).

A POR occurs every time  $V_{DD}$  crosses the voltage level approximately equivalent to the sum of one n-channel threshold ( $V_{TN}$ ) and one p-channel threshold ( $V_{TP}$ ), on a power-up or power-down condition. DS1780 SRAM contents get “scrambled” when  $V_{DD}$  falls below

the greater of one n-channel  $V_T$  or one p-channel  $V_T$ . Therefore, SRAM contents will always be in a defined state as supply voltage reaches the minimum spec level of 2.8V, even in a power supply brownout condition.

**Software Reset** – This condition is generated by writing a “1” to bit 4 of the configuration register. It has no effect on DS1780 register contents. It will however pull the  $\overline{RST}$  output to the active low state for a duration of 20 ms (minimum). When the  $\overline{RST}$  output goes active, this bit in the configuration register will clear itself. A Software Reset is only possible if Bit 7 of the INT Mask Register 2 (0x44h) is set to “1”.

**Device Initialization** – This condition is generated by writing a “1” to bit 7 of the configuration register. It will clear all registers in DS1780 memory to their default state except the Value RAM (0x20h – 0x3Dh) and analog output (0x19h). These locations will remain unchanged from their state before the initialization. This condition has no effect on the  $\overline{RST}$  output. This bit is self-clearing.

**Hardware Reset** – This condition is generated by some external source pulling the  $\overline{RST}$  pin below  $V_{IN}(0)$  (see DC Electrical Characteristics). The DS1780 will then force the  $\overline{RST}$  signal to remain in the active low state for >20 ms. It will clear all registers in DS1780 memory to their default state except the Value RAM (0x20h – 0x3Dh) and analog output (0x19h). These locations will remain unchanged from their state before the Hardware Reset.

### OPERATION – Configuration Register

Control of the DS1780 is provided through the configuration register. The Configuration Register is used to start and stop the DS1780, enable or disable interrupt output and modes, and provide the initialization function described above.

Bit 0 of the Configuration Register controls the monitoring loop of the DS1780. Setting Bit 0 low stops the monitoring loop and puts the DS1780 into a standby mode. 2-Wire Bus communication is still possible with any register in the DS1780 during the standby mode, however. Additionally, the DS1780 will continue to monitor the  $\overline{RST}$  and CHS inputs while in a standby mode. Setting Bit 0 high starts the monitoring loop.

Bit 1 of the Configuration Register enables or disables the  $\overline{INT}$  Interrupt output. Setting Bit 1 high enables the  $\overline{INT}$  output, setting bit 1 low disables the output.

Bit 3 of the Configuration Register is used to clear the  $\overline{INT}$  interrupt output when set high. The DS1780 monitoring function will stop until bit 3 is set low. Interrupt Status register contents will not be affected.

Bit 4 of the Configuration Register is used to initiate a minimum 20 ms RESET signal on the  $\overline{RST}$  output if the pin is configured for the RESET mode (via bit 7 of the INT Mask Register 2 – 0x44h).

Bit 6 of the Configuration Register is used to reset the Chassis Intrusion (CHS) output pin when set high.

Bit 7 of the Configuration Register is used to start a Configuration Register Initialization when taken high, as described in the “OPERATION – Resets” section.

### OPERATION – Monitoring Loop

The DS1780 monitoring function is started by doing a write to the Configuration Register and setting the INT\_Clear (Bit 3) low, and Start (Bit 0) high. At this point the INT\_Enable (Bit 1) should be set high to enable interrupts (INT). The DS1780 then performs a “round robin” sampling of the inputs, sampling each approximately once a second, in the order (corresponding to locations in the Value RAM) shown below in Table 3. The results of the sampling and conversions can be found in the Value RAM (Table 10.13) and are available at any time.

**DS1780 MONITORING ORDER** Table 3

TEMPERATURE READING	←
ANALOG +2.5 $V_S/V_{CCP2}$	
ANALOG +12V	
ANALOG +5V	
ANALOG +3.3V	
ANALOG +2.5V	
ANALOG + $V_{CCP1}$	
FAN1	
FAN2	

If conversions are terminated by either of the methods described in the “OPERATION – Configuration Register” section, the current “round-robin” loop will be completed and the results stored in RAM. Monitoring will then terminate. When the monitoring again commences, monitoring always starts with the temperature reading.

#### OPERATION – Temperature Data Format

The DS1780 internally converts measured temperature data to a 2’s complement data format (in °C). The host can read the last completed temperature conversion at any time by setting the Internal Address Register pointer to location 27h, and reading the 8 bits in the register. The format of the data is shown below in Table 4. The MSb of the register represents the sign bit of the temperature reading. For Fahrenheit usage, a lookup table or conversion routine must be used.

#### TEMPERATURE/DATA RELATIONSHIPS

Table 4

S	2 <sup>6</sup>	2 <sup>5</sup>	2 <sup>4</sup>	2 <sup>3</sup>	2 <sup>2</sup>	2 <sup>1</sup>	2 <sup>0</sup>
MSb	(unit = °C)						LSb

TEMPERATURE	DIGITAL OUTPUT (BINARY)	DIGITAL OUTPUT (HEX)
+125°C	0111 1101	7Dh
+25°C	0001 1001	19h
+1°C	0000 0001	01h
0°C	0000 0000	00h
-1°C	1111 1111	FFh
-25°C	1110 0111	E7h
-40°C	1101 1000	D8h

#### OPERATION – Voltage Data Format

The DS1780 contains inputs for directly monitoring the power supplies typically found in a PC (+12V, -12V, +5V, +3.3V, +2.5V, +V<sub>ccp</sub>). These inputs are scaled internally to a reference source, and converted via an 8-bit Delta-Sigma ADC (Analog-to-Digital Converter), thus allowing for a more accurate means of measurement since the voltages are referenced to a known value.

Since these inputs can be greater than V<sub>DD</sub>, they are not diode protected to the power rails. In addition, small external series resistors such as 510Ω should be put into the lines driving the DS1780 to prevent damaging the traces or power supplies should an accidental short connect two power supplies together.

The worse such accident would be connecting -12V to +12V; a total of 24V difference, with the series resistors this would draw a maximum of approximately 24 ma.

The internal scaling factor depends upon the particular input. The +12V<sub>IN</sub>, +5V<sub>IN</sub>, +3.3V<sub>IN</sub>, and +2.5V<sub>IN</sub> inputs are internally scaled such that the nominal value of the respective supply corresponds to 3/4 of full range, or a decimal count of 192. The approximate resolution is thus equal to:

$$\text{LSb} (V_{\text{NOM}}) \cong \frac{4/3 \cdot V_{\text{NOM}}}{256}$$

This is depicted below in Table 5.



**VOLTAGE/DATA RELATIONSHIPS FOR POSITIVE ONLY VOLTAGE INPUTS (+12V<sub>IN</sub>, +5V<sub>IN</sub>, +3.3V<sub>IN</sub>, and +2.5V<sub>IN</sub>)** Table 5

INPUT PIN	+12V <sub>IN</sub>	+5V <sub>IN</sub>	+3.3V <sub>IN</sub>	+2.5V <sub>IN</sub>
LSb WEIGHTING (mV)	62.5	26.0	17.2	13.0
ADC RESULT (BASE 10)	PIN VOLTAGE (V)	PIN VOLTAGE (V)	PIN VOLTAGE (V)	PIN VOLTAGE (V)
0	0	0	0	0
1	0.063	0.026	0.017	0.013
2	0.125	0.052	0.034	0.026
3	0.188	0.078	0.052	0.039
4	0.25	0.104	0.069	0.052
•	•	•	•	•
•	•	•	•	•
•	•	•	•	•
190	11.875	4.948	3.266	2.474
191	11.938	4.974	3.283	2.487
192	12.0	5.0	3.3	2.5
193	12.063	5.026	3.317	2.513
•	•	•	•	•
•	•	•	•	•
•	•	•	•	•
252	15.75	6.563	4.331	3.281
253	15.813	6.589	4.348	3.294
254	15.875	6.615	4.366	3.307
255	15.938	6.641	4.383	3.32

The other two voltage inputs use a slightly different scaling technique, due to the nature of the PC voltage they are monitoring. Because processor voltage ( $V_{CCP}$ ) can vary to 3.6V, the + $V_{CCP1}$  and +2.5V<sub>S</sub>/ $V_{CCP1}$  inputs are internally scaled such that the ADC result is 0h for a 0V input and the maximum value of FFh is returned for a voltage of 3.60V. This corresponds to an LSb weighting of 14.1 mV.

The inputs can also be used to monitor a negative supply, such as -12V. However, a resistor ladder and positive reference voltage ( $V_{REF}$ ) must be used (see Figure 1) such that input voltage to the DS1780 swings between 0V and +3.6V. Assuming the DS1780 + $V_{CCP1}$  and +2.5V<sub>S</sub>/ $V_{CCP2}$  pins have infinite input impedance and the  $V_{REF}$  is a perfect supply, then the resolution and range of -12V input are:

$$LSb(R_1, R_2) \cong \frac{3.6}{255} \cdot \left[ \frac{R_1 + R_2}{R_1} \right]$$

$$V_{MIN}(V_{REF}, R_1, R_2) \cong -\frac{R_2}{R_1} V_{REF}$$

$$V_{MAX}(V_{REF}, R_1, R_2) \cong V_{REF} - (V_{REF} - 3.6) \cdot \left[ \frac{R_1 + R_2}{R_1} \right]$$

If the +2.5V<sub>S</sub>/ $V_{CCP2}$  is to be used to monitor a secondary processor core voltage ( $V_{CCP2}$ ), R2 should be removed and R1=500Ω. Table 6 below shows the voltage/data relationship for these inputs in the ideal case. In this example,  $V_{REF}$ =+5.0V, R1=4.0KΩ, and R2=23.2KΩ.

Analog inputs will provide best accuracy when referred to the GNDA pin. A separate, low-impedance ground plane for analog ground, which provides a ground point for the voltage dividers and analog components, will provide best performance, but is not mandatory. Analog components such as voltage dividers should be located physically as close as possible to the DS1780.

The power supply bypass, the parallel combination of 10  $\mu\text{F}$  (electrolytic or tantalum) and 0.1  $\mu\text{F}$  (ceramic) bypass capacitors connected between pin 9 and ground, should also be located as close as possible to the DS1780.

**VOLTAGE/DATA RELATIONSHIPS FOR  $V_{\text{CCP}}$  VOLTAGE INPUTS ( $+V_{\text{CCP1}}$ ,  $+2.5V_{\text{S}}$ / $+V_{\text{CCP2}}$ )** Table 6

INPUT PIN	$+V_{\text{CCP1}}$	$+2.5V_{\text{S}}/+V_{\text{CCP2}}$
LSb WEIGHTING (mV)	14.1	96.0
	(Used to monitor $V_{\text{CCP}}$ )	(Used to monitor $-12V$ )
ADC RESULT (BASE 10)	PIN VOLTAGE (V)	SUPPLY VOLTAGE (V)
0	0	-29.0
1	0.014	-28.90
2	0.028	-28.81
3	0.042	-28.71
4	0.056	-28.62
•	•	•
•	•	•
•	•	•
136	1.920	-15.94
137	1.934	-15.85
138	1.948	-15.75
139	1.962	-15.66
•	•	•
•	•	•
•	•	•
252	3.558	-4.808
253	3.572	-4.712
254	3.586	-4.616
255	3.60	-4.52

**OPERATION – FAN Speed Data Format**

Inputs are provided for signals from fans equipped with tachometer outputs. These are logic-level inputs with an approximate threshold of 1.4V. Signal conditioning in the DS1780 accommodates the slow rise and fall times typical of fan tachometer outputs. The maximum input signal range is 0 to  $V_{\text{DD}}$ . In the event these inputs are supplied from fan outputs which exceed 0 to  $V_{\text{DD}}$ , either resistive division or diode clamping must be included to keep inputs within an acceptable range, as shown in Figure 3. R2 is selected so that it does not develop

excessive voltage due to input leakage. R1 is selected based on R2 to provide a minimum input of 2V and a maximum of  $V_{\text{DD}}$ . R1 should be as low as possible to provide the maximum possible input up to  $V_{\text{DD}}$  for best noise immunity. Alternatively, use a shunt reference or Zener diode to clamp the input level.

Tables 7 and 8 describe the format of the data stored in the FAN reading registers (Internal Address Registers 28h and 29h).

FAN TACHOMETER INPUT OPTIONS Figure 3

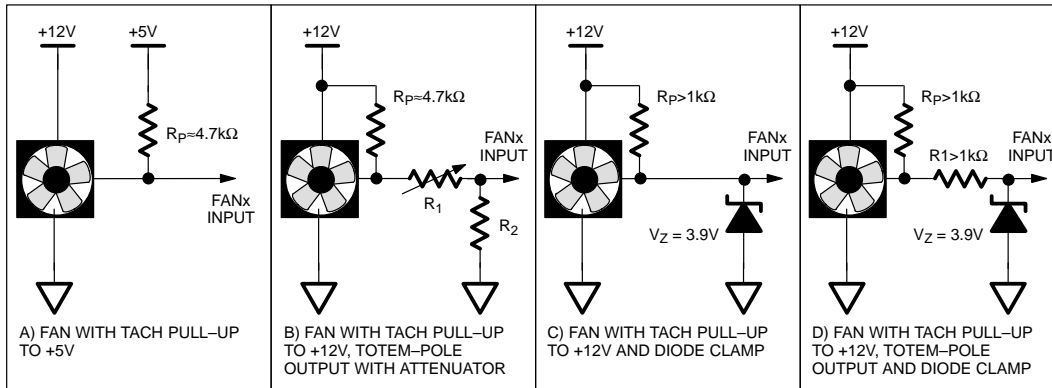

## VOLTAGE/DATA RELATIONSHIPS FOR FAN INPUTS (FAN1, FAN2) UNDER DEFAULT

(÷2) MODE Table 7

RPM	Time Per Revolution	Counts for 'Divide by 2' (default mode) in decimal	Comments
4400	13.64 ms	153	Typical RPM
3080	19.48 ms	219	70% RPM
2640	22.73 ms	255 (maximum)	60% RPM

## VOLTAGE/DATA RELATIONSHIPS FOR FAN INPUTS (FAN1, FAN 2) Table 8

MODE SELECT	NOMINAL RPM	TIME PER REVOLUTION	COUNTS FOR THE NOMINAL SPEED IN DECIMAL	70% RPM	TIME PER REVOLUTION FOR 70% RPM
Divide by 1	8800	6.82 ms	153	6160	9.74 ms
Divide by 2	4400	13.64 ms	153	3080	19.48 ms
Divide by 4	2200	27.27 ms	153	1540	38.96 ms
Divide by 8	1100	54.54 ms	153	770	77.92 ms

In general, the value stored in the FAN registers (in decimal) follows the equation:

$$\text{Count (RPM, Divisor)} \cong \frac{1.35 \times 10^6}{\text{RPM} \div \text{Divisor}}$$

If fans can be powered while the power to the DS1780 is off, the DS1780 inputs will provide diode clamping. Limit input current to the Input Current at Any Pin specification shown in the ABSOLUTE MAXIMUM RATINGS section. In most cases, open collector outputs with pull-up resistors inherently limit this current. If this maximum current could be exceeded, either a larger pull-up

resistor should be used or resistors connected in series with the fan inputs.

The Fan Inputs gate an internal 22.5 KHz oscillator for one period of the Fan signal into an 8-bit counter (maximum count = 255). The default divisor, located in the Fan Divisor/RST\_Register, is set to 2 (choices are 1, 2, 4, and 8) providing a nominal count of 153 for a 4400 rpm fan with two pulses per revolution. Typical practice is to consider 70% of normal RPM a fan failure, at which point the count will be 219.

### OPERATION – Interrupts

An external interrupt can come from the following sources. While the label suggests a specific type or source of Interrupt, this label is not a restriction on the usage; it could come from any desired source.

1. **Analog Voltage:** An interrupt will be generated if a analog voltage High or Low limit has been exceeded; this is generally when a power supply is out of its normal operating range.
2. **Temperature:** An interrupt will be generated if a High or a Low Hot Temperature limit has been exceeded.
3. **Fan speed:** An interrupt will be generated if a fan count limit has been exceeded.
4. **Chassis Intrusion:** This is an active high interrupt from any type of device that detects and captures chassis intrusion violations. This could be accomplished mechanically, optically, or electrically, and circuitry external to the DS1780 is expected to latch the event.

All System Management Interrupts (SMI's) are indicated in the two Interrupt Status Registers. The  $\overline{\text{INT}}$  output has individual mask registers and individual masks for each Interrupt. As described in the "OPERATION – Configuration Register" Section, this hardware Interrupt line can also be enabled/disabled in the Configuration Register.

Reading an Interrupt Status Register will output the contents of the Register, and reset the Register. A subsequent read done before the analog 'round-robin' monitoring loop is complete will indicate a cleared Register. Allow at least 1 second to allow all Registers to be updated between reads. In summary, the Interrupt Status Register clears upon being read, and requires at least 1 second to be updated. When the Interrupt Status Register clears, the hardware interrupt line will also clear until the Registers are updated by the monitoring loop.

The  $\overline{\text{INT}}$  hardware Interrupt output is cleared with the INT\_Clear bit, which is Bit 3 of the Configuration Register, without affecting the contents of the Interrupt Status Registers. When this bit is high, the DS1780 monitoring loop will stop. It will resume when the bit is low.

### Analog Voltage Limits

The limits for the analog voltage comparison are pro-

grammed into the Value RAM at Internal Address Registers 2Bh – 36h. A high and low limit is associated with each of the 6 analog voltage inputs of the DS1780. Care must be taken to program the limit registers in the same format as the respective voltage data register. Please see "OPERATION – Voltage Data Format" for details. For setting a voltage interrupt, the DS1780 compares on a "greater than" basis for high limits and a "less than or equal to" basis for low limits. The host can mask any or all of the voltage limits for interrupt contention.

### Temperature Limits and Interrupt Modes

The host programs an 8-bit High Temperature Limit and Hysteresis/Low Temperature Limit into the DS1780 at Internal Address Registers 39h and 3Ah in the same 2's complement format described in the "OPERATION – Temperature Data Format" section. The temperature mode is programmed into the Temperature Configuration Register (0x4Bh). A digital 8-bit comparator is also incorporated that compares the temperature readings to the programmed limits.

There are three interrupt modes of operation. The  $\overline{\text{INT}}$  output can be programmed for either of the three interrupt modes of operation and the host can program the DS1780 to completely mask temperature interrupts from controlling the  $\overline{\text{INT}}$  output.

1. **One-time Interrupt mode:** Exceeding hot temperature limit causes an SMI that will remain active indefinitely until reset by reading Interrupt Status Register 1 or cleared by the INT\_Clear bit in the Configuration register. Once an SMI event has occurred by crossing the hot temperature limit, then subsequently reset, an SMI will not occur again until the temperature goes below hot temperature hysteresis (low) limit.
2. **Default Interrupt mode:** Exceeding hot temperature limit causes an System Management Interrupt (SMI) that will remain active indefinitely until reset by reading Interrupt Status Register 1 or cleared by the INT\_Clear bit in the Configuration register. Once an Interrupt event has occurred by crossing the Hot Temperature limit, then reset, an Interrupt will occur again once the next temperature conversion has completed. The interrupts will continue to occur in this manner until the temperature goes below the hot temperature hysteresis value.

- 3. Comparator mode:** Exceeding hot temperature limit causes the SMI output to go active. SMI will remain active until the temperature goes below the hot temperature limit. Once the temperature goes below the hot temperature limit, SMI will become inactive. As in the default and one-time interrupt modes, the SMI can also be cleared by reading Interrupt Status Register 1 or by setting the INT\_Clear bit in the configuration register.

Figure 4 below illustrates the 3 temperature interrupt modes.

### Fan Speed Limits

The host programs 8-bit fan speed low limits for FAN1 and FAN2 inputs into Internal Address Registers 3Bh and 3Ch, respectively. Care must be taken to program the limit with respect to the divisor chosen for each of the tachometer inputs. Refer to the "OPERATION – FAN Speed Data Format" section for details. An interrupt will occur if measured fan speed falls below the programmed limit. Due to the nature of the algorithm implemented, a count of 255 (max) represents a slow (or

stopped) fan; i.e., tachometer counts are inversely proportional to fan speed. Thus, the fan limit register will contain the maximum number of counts (or the minimum fan speed) before which an interrupt will occur.

### Chassis Intrusion Detection

The CHS input is an active high interrupt from any type of device that detects and captures chassis intrusion violations. This could be accomplished mechanically, optically, or electrically, and circuitry external to the DS1780 is expected to latch the event.

The design of the DS1780 allows this input to go high even with no power applied to the DS1780, and no clamping or other interference with the line will occur. This line can also be pulled low for at least 20 ms by the DS1780 to reset a typical Chassis Intrusion circuit. Accomplish this reset by setting Bit 6 of Configuration Register high. The bit in the Register is self-clearing.

A possible chassis intrusion detector/latch is shown below in Figure 5.

TEMPERATURE INTERRUPT MODE ILLUSTRATION Figure 4

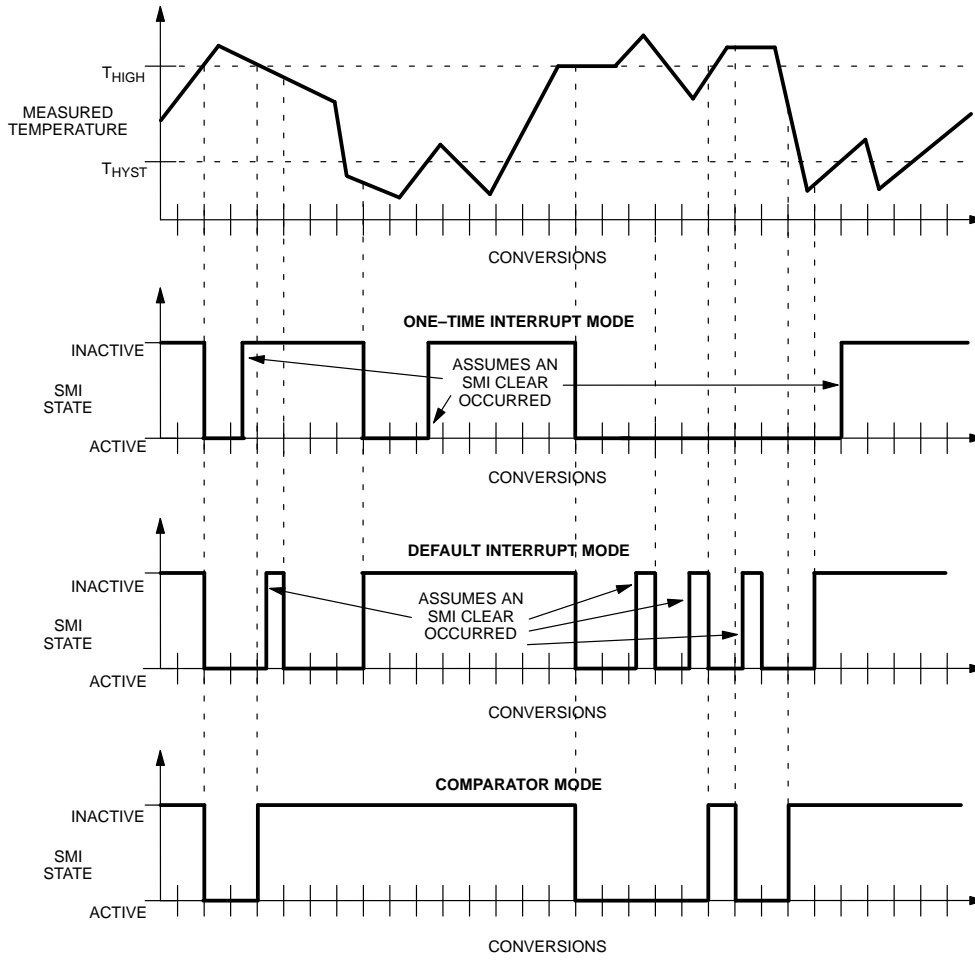

**SAMPLE CHASSIS INTRUSION DETECTOR/LATCH** Figure 5

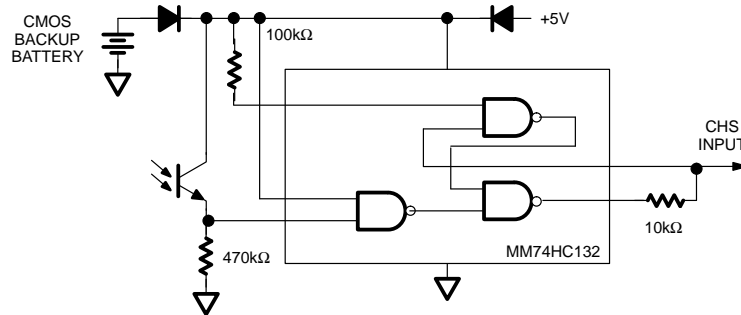

**OPERATION – Analog Output**

The DS1780 has a single analog output from a unsigned 8-bit D/A which produces 0–1.25 volts; this is amplified and scaled with external circuitry such as a op-amp and transistor to provide fan speed control. This register is set to 0xFF on power-up, which produces full fan speed. The analog output register (19h) is unaffected by any reset other than power-on.

This voltage must be scaled and have a output current of at least 250 mA which is needed to drive the fans; Figure 6 is a simple circuit that can be used, and Table 9 suggest R1 and R2 to select gain.

Although it is recommended to connect the DS1780 analog output to a high impedance node such as that in Figure 6, the output driver can source 2.0 mA (max) at  $V_{OUT} = 1.25V$  while maintaining the error spec of 5% of FSR over temperature and supply voltage. Stability is guaranteed for a load capacitance up to 100 pF. More capacitance could cause severe overshoots and possible oscillation.

**FAN AMPLIFIER CIRCUIT EXAMPLE** Figure 6

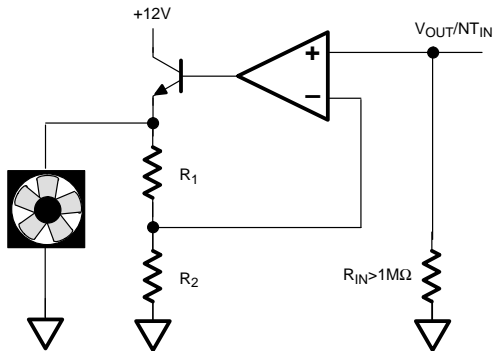

**AMPLIFIER DESIGN EXAMPLES** Table 9

<b>Input</b>	<b>1.22</b>
<b>Output</b>	<b>12</b>
<b>Gain</b>	<b>9.84</b>
<b>R1</b>	<b>R2</b>
1,000	9,000
2,200	19,439
3,300	29,159
4,700	41,530
10,000	88,361

**OPERATION – NAND TREE Test**

A NAND tree is provided in the DS1780 for Automated Test Equipment (ATE) board level connectivity testing. If the user applies ( $V_{DD} - 0.5V$ ) to the  $NT_{IN}$  input, the device will be in the NAND tree test mode.  $A0/NT_{OUT}$  will become the NAND tree output pin. To perform a NAND tree test all pins included in the NAND tree (see Figure 7 below) should be driven high.

Beginning with A1 and working around the chip, each pin can be toggled and a resulting toggle can be observed on  $A0/NT_{OUT}$ .

Allow for a typical propagation delay of 100 ns.

**Note:** To properly implement the NAND TREE test on the PCB, no pins listed in the tree should be connected directly to power or ground; if a pin is needed to configure as a permanent low, such as an address, it should be connected to ground through a low value resistor such as 330( to allow the ATE (Automatic Test Equipment) to drive it high.

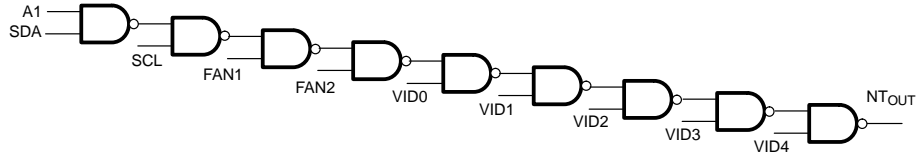
**DS1780 NAND TREE TEST FLOW** Figure 7**DS1780 REGISTERS AND RAM****INTERNAL ADDRESS REGISTER** Table 10.0

BIT	NAME	R/W	DESCRIPTION
<7:0>	Address Pointer	W	Address of RAM and Registers. See the tables below for detail.

**ADDRESS POINTER (POWER ON DEFAULT 00h)** Table 10.1

REGISTERS AND RAM	<A7:A0> (HEX)	POWER ON VALUE OF REGISTERS: <7:0> (BINARY)
Configuration Register	40h	0000 1000
Interrupt $\overline{\text{INT}}$ Status Register 1	41h	0000 0000
Interrupt $\overline{\text{INT}}$ Status Register 2	42h	0000 0000
$\overline{\text{INT}}$ Mask Register 1	43h	0000 0000
$\overline{\text{INT}}$ Mask Register 2	44h	0000 0000
Chassis Intrusion Clear Register	46h	0000 0000
VID Register	47h	<7:4> = 0101, <3:0> = VID3 – VID0
Serial Address Register	48h	0010 1101
VID 4 Register	49h	<7:1> = 1000 000, <0>=VID 4
Temperature Configuration Register	4Bh	0000 0001
Test Register	15h	0000 0000
Analog Output	19h	1111 1111
Value RAM	20h–3Dh	
Company ID	3Eh	1101 1010
Stepping	3Fh	0000 0001



**CONFIGURATION REGISTER (ADDRESS 0X40; POWER-UP DEFAULT = 08h) Table 10.2**

BIT	NAME	R/W	DESCRIPTION
0	START	R/W	Logic 1 enables startup of measurement loop, logic 0 places the DS1780 in standby mode. Caution: The $\overline{\text{INT}}$ output pin will not be cleared if the user writes a zero to this location after an interrupt has occurred (see "INT Clear" bit). At startup, limit checking functions and scanning begins. Note, all HIGH and LOW LIMITS should be set into the DS1780 prior to turning on this bit. (Power-up default=0).
1	INT Enable	R/W	Logic 1 enables the $\overline{\text{INT}}$ output. 1=Enabled 0=Disabled (Power-up Default = 0).
2	Reserved	R/W	Power-up Default = 0.
3	INT Clear	R/W	During Interrupt Service Routine (ISR) this bit asserted logic 1 clears $\overline{\text{INT}}$ output without affecting the contents of the Interrupt Status Registers. The device will stop monitoring. It will resume upon clearing of this bit. (Power-up default=1).
4	RESET	R/W	Creates a RESET (Active Low) signal for 20 ms (min) on the $\overline{\text{RST}}$ output. (Power-up default = 0) This bit is cleared once the $\overline{\text{RST}}$ pulse goes active.
5	Reserved	R/W	Power-up Default = 0.
6	CHS Reset	R/W	Logic 1 resets the chassis intrusion pin. (Power-up default = 0). This bit is cleared after CHS becomes cleared.
7	Initialization	R/W	Logic 1 restores power-up default values to all DS1780 registers except for the analog output and value RAM, which remain unchanged. This bit automatically clears itself since the power on default is zero.

**INTERRUPT INT STATUS REGISTER 1 (ADDRESS 0X41; POWER-UP DEFAULT = 00h) Table 10.3**

BIT	NAME	R/W	DESCRIPTION
0	+2.5V_Error	R	A one indicates a High or Low limit has been exceeded.
1	Vccp1_Error	R	A one indicates a High or Low limit has been exceeded.
2	+3.3V_Error	R	A one indicates a High or Low limit has been exceeded.
3	+5V_Error	R	A one indicates a High or Low limit has been exceeded.
4	Temp_Error	R	A "1" indicates that a high or low temperature limit has been exceeded. The conditions that will generate and clear this bit depend upon the temperature interrupt mode chosen. The mode is set at bits 0 and 1 of the Temperature Configuration Register (0x48h).
5	Reserved	R	"0".
6	FAN1_Error	R	A one indicates that a fan count limit has been exceeded.
7	FAN2_Error	R	A one indicates that a fan count limit has been exceeded.

**INTERRUPT INT STATUS REGISTER 2 (ADDRESS 0X42; POWER-UP  
DEFAULT=00h) Table 10.4**

BIT	NAME	R/W	DESCRIPTION
0	+12V_Error	R	A one indicates a High or Low limit has been exceeded.
1	-12V/ Vccp2_Error	R	A one indicates a High or Low limit has been exceeded.
2	Reserved	R	"0".
3	Reserved	R	"0".
4	Chassis_Error	R	A one indicates Chassis Intrusion has gone high.
5	Reserved	R	"0".
6	Reserved	R	"0".
7	Reserved	R	"0".

**Note:** Anytime the  $\overline{\text{INT}}$  Status Registers are read out, the conditions (i.e., Registers) that are read are automatically reset to power-up state (except CHS, which can only be cleared by CHS reset). In the case of the VOLTAGE priority indication, if two or more Voltages were out of LIMITS, then another indication would automatically be generated if it was not handled during the ISR.

The errant voltage may be masked until the operator has time to clear the errant condition or set the limit higher/lower.

**INT MASK REGISTER 1 (ADDRESS 0X43; POWER-UP DEFAULT=00h) Table 10.5**

BIT	NAME	R/W	DESCRIPTION
0	+2.5V	R/W	A one disables the corresponding interrupt status bit for $\overline{\text{INT}}$ interrupt.
1	+Vccp1	R/W	A one disables the corresponding interrupt status bit for $\overline{\text{INT}}$ interrupt.
2	+3.3V	R/W	A one disables the corresponding interrupt status bit for $\overline{\text{INT}}$ interrupt.
3	+5V	R/W	A one disables the corresponding interrupt status bit for $\overline{\text{INT}}$ interrupt.
4	Temp	R/W	A one disables the corresponding interrupt status bit for $\overline{\text{INT}}$ interrupt.
5	Reserved	R/W	Power on default = 0.
6	FAN1	R/W	A one disables the corresponding interrupt status bit for $\overline{\text{INT}}$ interrupt.
7	FAN2	R/W	A one disables the corresponding interrupt status bit for $\overline{\text{INT}}$ interrupt.

**INT MASK REGISTER 2 (ADDRESS 0X44; POWER-UP DEFAULT=00h)** Table 10.6

BIT	NAME	R/W	DESCRIPTION
0	+12V	R/W	A one disables the corresponding interrupt status bit for $\overline{\text{INT}}$ interrupt.
1	-12V/Vccp2	R/W	A one disables the corresponding interrupt status bit for $\overline{\text{INT}}$ interrupt.
2	Reserved	R/W	Power-up Default = 0.
3	Reserved	R/W	Power-up Default = 0.
4	CHS_sec (Chassis Intrusion)	R/W	A one disables the corresponding interrupt status bit for $\overline{\text{INT}}$ interrupt.
5	Reserved	R/W	Power-up Default = 0.
6	Reserved	R/W	Power-up Default = 0.
7	Reset Enable	R/W	A one enables the RESET in the configuration register.

**RESERVED REGISTER (ADDRESS 0X45; POWER-UP DEFAULT=00h)** Table 10.7

BIT	NAME	R/W	DESCRIPTION
<7:0>	RESERVED	R/W	Undefined (Power On = 00h).

**CHASSIS INTRUSION CLEAR REGISTER (ADDRESS 0X46; POWER-UP DEFAULT=00h)** Table 10.8

BIT	NAME	R/W	DESCRIPTION
0-6	RESERVED	R/W	Undefined (Power On = 00h).
7	Chassis Int Clear	R/W	A one outputs a minimum 20 ms active low pulse on the Chassis Intrusion (CHS) pin. The register bit clears itself after the pulse has been output.

**VID REGISTER (ADDRESS 0x47; POWER-UP DEFAULT = SEE "ADDRESS POINTER" TABLE)** Table 10.9

BIT	NAME	R/W	DESCRIPTION
0-3	VID	R	The VID[3:0] inputs from Pentium/PRO power supplies to indicate the operating voltage (e.g., 1.5V to 2.9V).
4-5	FAN1 RPM control	R/W	FAN1 Speed Control. <5:4> = 00 – divide by 1 <5:4> = 01 – divide by 2 <5:4> = 10 – divide by 4 <5:4> = 11 – divide by 8
6-7	FAN2 RPM control	R/W	FAN2 Speed Control. <7:6> = 00 – divide by 1 <7:6> = 01 – divide by 2 <7:6> = 10 – divide by 4 <7:6> = 11 – divide by 8

**SERIAL ADDRESS REGISTER (ADDRESS 0x48; POWER-UP DEFAULT = SEE DESCRIPTION BELOW) Table 10.10**

BIT	NAME	R/W	DESCRIPTION
0-7	2-Wire Bus Address	R/W	2-Wire Bus Address (Power On = 001011(A1)(A0)).

**VID4 REGISTER (ADDRESS 0x49; POWER-UP DEFAULT = SEE DESCRIPTION BELOW) Table 10.11**

BIT	NAME	R/W	DESCRIPTION
0	VID 4	R	VID4 Input.
1-7	Reserved	R/W	Default Power On Values = 1000000.

**TEMPERATURE CONFIGURATION REGISTER (ADDRESS 0x4B; POWER-UP DEFAULT = 01h) Table 10.12**

BIT	NAME	R/W	DESCRIPTION
0	Hot Temperature Interrupt mode select Bit 0	R/W	If Bits 0 and Bits 1 of this register are both zero or both one, this selects the default interrupt mode which gives the user an interrupt if the temperature goes above the hot limit. The interrupt will be cleared once the status register is read, but it will again be generated when the next conversion has completed. It will continue to do so until the temperature goes below the hysteresis limit.  A zero on Bit 1 and a one on Bit 0 selects the one time interrupt mode which gives the user an indefinite interrupt when it goes above the hot limit. The interrupt will be cleared once the status register is read. Another interrupt will not be generated until the temperature first goes below the hysteresis limit. It will also be cleared if the status register is read. No more interrupts will be generated until the temperature goes above the hot limit again. The corresponding bit will be cleared in the status register every time it is read but may not set again when the next conversion is done.
1	Hot Temperature Interrupt mode select Bit 1	R/W	A one on this bit (Bit 1) and a zero on Bit 0 selects the comparator mode. This gives an SMI when the temperature exceeds the hot limit. This SMI remains active until the status register is read or the temperature goes below the hot limit (no hysteresis), when the SMI will become inactive.
2-6	Reserved	R/W	Default = 00000.
7	Temp [0]	R	Ninth bit of the temperature (Value = 0.5°C).

**TEST REGISTER (ADDRESS 0x15h; POWER-UP DEFAULT = 00h) Table 10.13**

ADDRESS <A7:A0>h	R/W	DESCRIPTION
15h	Note 3	Power-up Default = 00h.

**ANALOG OUTPUT (ADDRESS 0x19h; POWER-UP DEFAULT = FFh) Table 10.14**

ADDRESS <A7:A0>h	R/W	DESCRIPTION
19h	R/W	Power-up Default = FFh. No other reset affects this register. FFh value set analog out to MAX value = 1.25V.

**VALUE RAM (ADDRESS 0x15h – 0x3Dh) Table 10.15**

ADDRESS <A7:A0>h	R/W	DESCRIPTION
20h	R	+2.5V Input Reading.
21h	R	Vccp1 Input Reading.
22h	R	+3.3V Input Reading.
23h	R	+5V Input Reading.
24h	R	+12V Input Reading.
25h	R	+2.5V_Sense /Vccp2 Input Reading.
26h	R	Reserved.
27h	R	Temperature reading (Most significant 8–bits).
28h	R	FAN1 reading: This location stores the number of counts of the internal clock per revolution.
29h	R	FAN2 reading: This location stores the number of counts of the internal clock per revolution.
2Ah	R/W	Reserved.
2Bh	R/W	+2.5V High Limit (Note 1, 2).
2Ch	R/W	+2.5V Low Limit (Note 2).
2Dh	R/W	+Vccp1 High Limit (Note 1, 2).
2Eh	R/W	+Vccp1 Low Limit (Note 2).
2Fh	R/W	+3.3V High Limit (Note 1, 2).
30h	R/W	+3.3V Low Limit (Note 2).
31h	R/W	+5V High Limit (Note 1, 2).
32h	R/W	+5V Low Limit (Note 2).
33h	R/W	+12V High Limit (Note 1, 2).
34h	R/W	+12V Low Limit (Note 2).
35h	R/W	+2.5V_Sense/Vccp2 High Limit (Note 1, 2).
36h	R/W	+2.5V_Sense/Vccp2 Low Limit (Note 2).
37h		Reserved.
38h		Reserved.
39h	R/W	Hot Temperature (High) Limit (Note 1).
3Ah	R/W	Hot Temperature Hysteresis (Low) Limit.

**Value RAM (Addresses 0x15h – 0x3Dh) Table 10.13 (cont'd)**

ADDRESS <A7:A0>h	R/W	DESCRIPTION
3Bh	R/W	FAN1 Fan Count Limit: It is the number of counts of the internal clock for the Low Limit of the fan speed.
3Ch	R/W	FAN2 Fan Count Limit: It is the number of counts of the internal clock for the Low Limit of the fan speed.
3Dh		Reserved.
3Eh	R	Company id number (Note 5).
3Fh	R	Stepping id number (Note 6).

**NOTES:**

1. Setting all ones to the high limits for voltages and fans (0111 1111 binary for temperature) means interrupts will never be generated except the case when voltages go below the low limits.
2. For the high limits of the voltages, the device is doing a greater than comparison. For the low limits, however, it is doing a less than or equal comparison.
3. This register should only be used by the manufacturer for testing of the ASIC. Reading or writing to this register during normal use may lead to erroneous events.
4. This register will latch an 8-bit value into an R-2R D/A to provide a range of 0–1.25 volts, accuracy can be  $\pm 5\%$  or more.
5. This location will contain the company identification number which will be used by software to determine analog voltage curves, this register is read only.
6. This location will contain the stepping number of the part, this register is read only.

**ABSOLUTE MAXIMUM RATINGS\***

Voltage on $V_{DD}$	(GNDD–0.3V) to +6.5V
Voltage on any other pin (except Analog Inputs)	(GNDD–0.3V) to ( $V_{DD} + 0.3V$ )
Voltage at +12V <sub>IN</sub> pin	(GNDD–0.3V) to 18V
Voltage at other Analog input pins	(GNDD–0.3V) to 7.0V
Ground Difference (GNDD–GNDA)	±0.3V
Input Current at any Pin (Note 2)	±5 mA
Package Input Current (Note 2)	±20 mA
Operating Temperature	–40°C to +125°C
Storage Temperature	–65°C to +150°C
ESD Susceptibility (Human Body Model)	2kV
Soldering Temperature (Note 3)	215°C for 60 seconds (Vapor Phase) 220°C for 15 seconds (IR)

\* This is a stress rating only and functional operation of the device at these or any other conditions above those indicated in the operation sections of this specification is not implied. Exposure to absolute maximum rating conditions for extended periods of time may affect reliability.

The Dallas Semiconductor DS1780 is built to the highest quality standards and manufactured for long term reliability. All Dallas Semiconductor devices are made using the same quality materials and manufacturing methods. However, the DS1780 is not exposed to environmental stresses, such as burn-in, that some industrial applications require. For specific reliability information on this product, please contact the factory in Dallas at (972) 371–4448.

**RECOMMENDED DC OPERATING CONDITIONS** (–40°C to +125°C, 2.8V ≤  $V_{DD}$  ≤ 5.75V)

PARAMETER	SYMBOL	CONDITION	MIN	TYP	MAX	UNITS	NOTES
Supply Voltage	$V_{DD}$		2.8		5.75	V	
Ground Difference	$\Delta GND$	GNDD–GNDA			0.1	V	
Digital Input Voltage	$V_{IND}$		–0.05		$V_{DD} + 0.05$	V	

**DC ELECTRICAL CHARACTERISTICS****Power Supply**(–40°C to +125°C, 2.8V ≤  $V_{DD}$  ≤ 5.75V)

PARAMETER	SYMBOL	CONDITION	MIN	TYP	MAX	UNITS	NOTES
Supply Current	$I_{DD}$	Active ADC and DAC, Interface Inactive		0.7	1.0	mA	4, 5
		ADC, DAC and Interface Inactive		125		μA	
		Inactive ADC and Interface, DAC Active		250	500	μA	

**DC ELECTRICAL CHARACTERISTICS:****Temperature-to-Digital Converter**(–40°C to +125°C, 2.8V ≤  $V_{DD}$  ≤ 5.75V)

PARAMETER	SYMBOL	CONDITION	MIN	TYP	MAX	UNITS	NOTES
Thermometer Error	$T_{ERR}$	–40°C ≤ TA ≤ 125°C			±3	°C	
		–25°C ≤ TA ≤ 100°C			±2		
Resolution			0.5			°C	

**DC ELECTRICAL CHARACTERISTICS:****Voltage-to-Digital Converter**(-40°C to +125°C, 2.8V ≤ V<sub>DD</sub> ≤ 5.75V)

PARAMETER	SYMBOL	CONDITION	MIN	TYP	MAX	UNITS	NOTES
ADC Resolution					8	bits	
Voltage to Digital Conversion Resolution (See Voltage A/D Section)		+2.5V <sub>IN</sub> Input		13.0		mV	
		+3.3V <sub>IN</sub> Input		17.2			
		+5V <sub>IN</sub> Input		26.0			
		+12V <sub>IN</sub> Input		62.5			
		+V <sub>CCP1,2</sub> Inputs		14.1			
		+2.5V <sub>S</sub> Input		64.0			
Total Unadjusted Error	TUE				±1	%	6
Differential Nonlinearity	DNL				±1	LSb	
Power Supply Sensitivity	PSS			±1		%/V	
Monitoring Cycle	t <sub>C</sub>			0.5	1.0	s	7
Input Resistance	R <sub>IN</sub>		500k	750k		Ω	

**DC ELECTRICAL CHARACTERISTICS:****Fan RPM-to-Digital Converter**(-40°C to +125°C, 2.8V ≤ V<sub>DD</sub> ≤ 5.75V)

PARAMETER	SYMBOL	CONDITION	MIN	TYP	MAX	UNITS	NOTES
Accuracy		+25°C ≤ TA ≤ +75°C			±6	%	
		-10°C ≤ TA ≤ +100°C			±12		
Full scale count					255	decimal	
FAN1 & FAN2 Nominal Input RPM		Divisor=1; Fan Count=153		8800		RPM	8
		Divisor=2; Fan Count=153		4400			
		Divisor=4; Fan Count=153		2200			
		Divisor=8; Fan Count=153		1100			
Internal Oscillator Frequency		+25°C ≤ TA ≤ +75°C	21.15	22.5	23.85	KHz	



**DC ELECTRICAL CHARACTERISTICS:****Analog Output  $V_{OUT}$** (-40°C to +125°C, 2.8V ≤  $V_{DD}$  ≤ 5.75V)

PARAMETER	SYMBOL	CONDITION	MIN	TYP	MAX	UNITS	NOTES
DAC Resolution					8	bits	
Voltage Range			0		1.25	V	
Error	$DAC_{ERR}$				±5	% of FSR	
Output Current	$I_{OUT}$				2.0	mA	
Load Capacitance	$C_{LOAD}$				100	pF	

**DC ELECTRICAL CHARACTERISTICS:****Digital Outputs:  $A0NT_{OUT}$** (-40°C to +125°C, 2.8V ≤  $V_{DD}$  ≤ 5.75V)

PARAMETER	SYMBOL	CONDITION	MIN	TYP	MAX	UNITS	NOTES
Logical "1" Output Voltage	$V_{OUT(1)}$	$I_{OUT}=\pm 5$ mA at $V_{DD}=4.25$ V	2.4			V	
		$I_{OUT}=\pm 3$ mA at $V_{DD}=2.85$ V					
Logical "0" Output Voltage	$V_{OUT(0)}$	$I_{OUT}=\pm 5$ mA at $V_{DD}=5.75$ V			0.4	V	
		$I_{OUT}=\pm 3$ mA at $V_{DD}=3.45$ V					

**DC ELECTRICAL CHARACTERISTICS:****Open-drain Digital Outputs:  $\overline{RST}$ , CHS,  $\overline{INT}$** (-40°C to +125°C, 2.8V ≤  $V_{DD}$  ≤ 5.75V)

PARAMETER	SYMBOL	CONDITION	MIN	TYP	MAX	UNITS	NOTES
Logical "0" Output Voltage	$V_{OUT(0)}$	$I_{OUT}=\pm 5$ mA at $V_{DD}=5.75$ V	0.4			V	
		$I_{OUT}=\pm 3$ mA at $V_{DD}=3.45$ V					
High Level Output Current	$I_{OH}$	$V_{OUT}=V_{DD}$		0.1	100	μA	
Active Pulse Width		$\overline{RST}$ and CHS	20	45		ms	

**DC ELECTRICAL CHARACTERISTICS:****Open-drain 2-Wire Bus Output: SDA**(-40°C to +125°C, 2.8V ≤  $V_{DD}$  ≤ 5.75V)

PARAMETER	SYMBOL	CONDITION	MIN	TYP	MAX	UNITS	NOTES
Logical "0" Output Voltage	$V_{OUT(0)}$	$I_{OUT}=\pm 5$ mA at $V_{DD}=5.75$ V	0.4			V	
		$I_{OUT}=\pm 3$ mA at $V_{DD}=3.45$ V					
High Level Output Current	$I_{OH}$	$V_{OUT}=V_{DD}$		0.1	100	μA	

**DC ELECTRICAL CHARACTERISTICS:****2-Wire Bus Digital Inputs: SDA, SCL**(-40°C to +125°C, 2.8V ≤ V<sub>DD</sub> ≤ 5.75V)

PARAMETER	SYMBOL	CONDITION	MIN	TYP	MAX	UNITS	NOTES
Logical "1" Input Voltage	V <sub>IN(1)</sub>		0.7V <sub>DD</sub>			V	
Logical "0" Input Voltage	V <sub>IN(0)</sub>				0.3V <sub>DD</sub>	V	

**DC ELECTRICAL CHARACTERISTICS:****Digital Inputs: A0/NT<sub>OUT</sub>, A1, CHS, VID0-4, FAN1, FAN2**(-40°C to +125°C, 2.8V ≤ V<sub>DD</sub> ≤ 5.75V)

PARAMETER	SYMBOL	CONDITION	MIN	TYP	MAX	UNITS	NOTES
Logical "1" Input Voltage	V <sub>IN(1)</sub>	V <sub>DD</sub> =5.0V	2.4			V	
Logical "0" Input Voltage	V <sub>IN(0)</sub>	V <sub>DD</sub> =5.0V			0.8	V	
Logical "1" Input Voltage	V <sub>IN(1)</sub>	V <sub>DD</sub> =3.3V	2.0			V	
Logical "0" Input Voltage	V <sub>IN(0)</sub>	V <sub>DD</sub> =3.3V			0.4	V	

**DC ELECTRICAL CHARACTERISTICS:****All Digital Inputs**(-40°C to +125°C, 2.8V ≤ V<sub>DD</sub> ≤ 5.75V)

PARAMETER	SYMBOL	CONDITION	MIN	TYP	MAX	UNITS	NOTES
Logical "1" Input Current	I <sub>IN(1)</sub>	V <sub>IN</sub> =V <sub>DD</sub>	-1	-0.005		μA	
Logical "0" Input Current	I <sub>IN(0)</sub>	V <sub>IN</sub> =0V		0.005	1	μA	
Input Capacitance	C <sub>IN</sub>			20		pF	

**AC ELECTRICAL CHARACTERISTICS:****2-Wire Interface**(-40°C to +125°C, 2.8V ≤ V<sub>DD</sub> ≤ 5.75V)

PARAMETER	SYMBOL	CONDITION	MIN	TYP	MAX	UNITS	NOTES
SCL Clock Period	t <sub>1</sub>		2.5			μs	
Data In Setup Time to SCL High	t <sub>2</sub>		100			ns	
Data Out Stable after SCL Low	t <sub>3</sub>		0			ns	
SDA Low Setup Time to SCL Low (START)	t <sub>4</sub>		100			ns	
SDA High Hold Time after SCL High (STOP)	t <sub>5</sub>		100			ns	

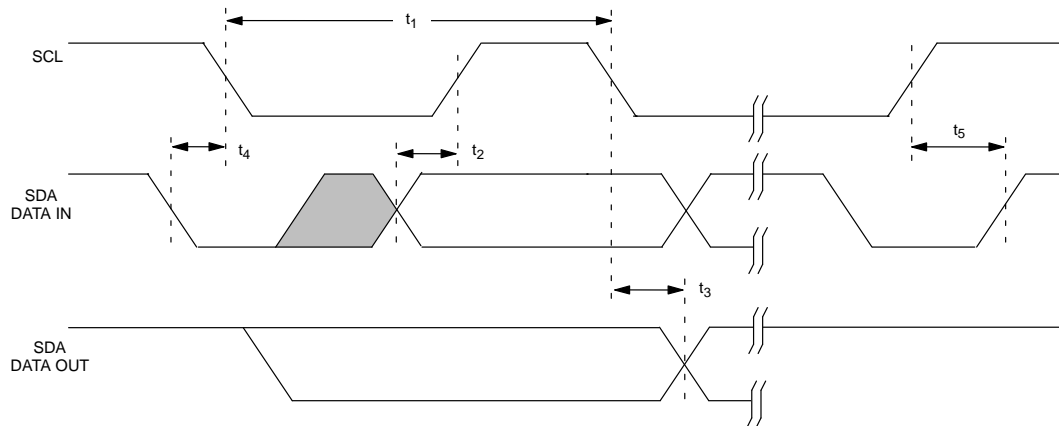
**2-WIRE BUS TIMING DIAGRAM** Figure 8**NOTES:**

1. All voltages are referenced to ground, unless otherwise specified.
2. When the input voltage ( $V_{IN}$ ) at any pin exceeds the power supplies ( $V_{IN} < (GND \text{ or } GND_A)$  or  $V_{IN} > V_{DD}$ , except for analog voltage inputs), the current at that pin should be limited to 5 mA. The 20 mA maximum package input current rating limits the number of pins that can safely exceed the power supplies with an input current of 5 mA to four.
3. Solder according to IPC standards.
4.  $I_{DD}$  specified with open-drain output pin open.
5.  $I_{DD}$  specified with  $V_{CC}$  at 5.0V and  $SDA, SCL = 5.0V$ .
6. TUE (Total Unadjusted Error) includes Offset, Gain and Linearity errors of the ADC.
7. Monitoring Cycle Time includes temperature conversion, voltage conversions, and fan speed readings.
8. The total fan count is based on 2 pulses per revolution of the fan tachometer output.
9. Limits (Min and Max specs) are defined for the full temperature range  $-40^{\circ}\text{C} \leq T_A \leq +125^{\circ}\text{C}$  and voltage range  $2.8\text{V} \leq V_{DD} \leq 5.75\text{V}$ , unless otherwise stated as a condition. Typical values represent parametric norms at  $T_A = 25^{\circ}\text{C}$  at  $4.5\text{V} \leq V_{DD} \leq 5.5\text{V}$ , unless otherwise stated as a condition.

**DS1780 24 LD. TSSOP**

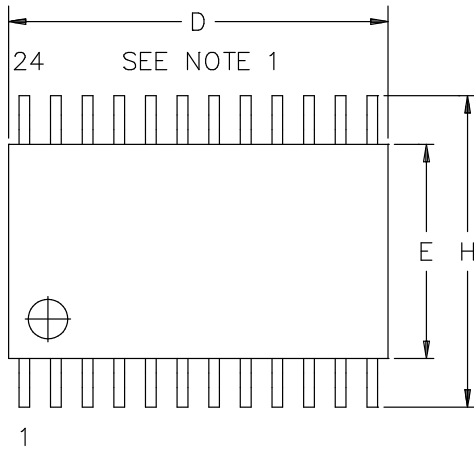

NOTES:

- 1. DIMENSION "D" INCLUDES MOLD MISSMATCH, FLASH, AND PROTRUSIONS.

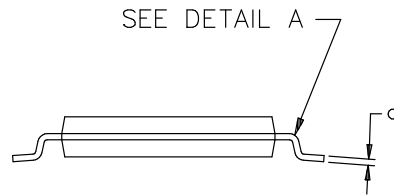
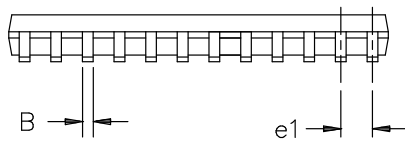

DIM	MIN	MAX
A	-	1.10
A1	0.05	-
A2	0.75	1.05
c	0.09	0.18
phi	0°	8°
L	0.50	0.70
e1	0.65	BSC
B	0.18	0.30
D	7.55	8.00
E	4.40	NOM
G	0.25	REF
H	6.25	6.55

