

FEATURES

- Fully compliant with SCSI-1, Fast SCSI and Ultra SCSI
- Pin compatible to the DS2107AE and DS21S07AE
- Provides active termination for nine signal lines
- Supports TERMPWR 2.7V – 5.50V
- Low dropout voltage regulator
- Power-down mode isolates termination resistors from the bus
- SCSI bus hot-plug compatible
- Fully supports actively negated SCSI signals
- Onboard thermal shutdown circuitry
- 20-pin plastic TSSOP (Thin Shrink Small Outline Package) (DS2116E)

DESCRIPTION

Fast SCSI and Ultra SCSI require the use of active terminations at both ends of every cable segment in a SCSI system with single-ended drivers and receivers. The DS2116 SCSI Terminator, which is fully compliant with these standards, enables the designer to gain the benefits of active termination: greater immunity to voltage drops on the TERMPWR (TERMination PoWeR) line, enhanced high-level noise immunity, intrinsic TERMPWR decoupling, and very low quiescent current consumption. The DS2116 integrates a regulator and nine precise switched 110 ohm termination resistors into a monolithic IC. The DS2116 can be electrically isolated from the SCSI bus without physical removal from the SCSI device.

FUNCTIONAL DESCRIPTION

The DS2116 consists of a bandgap reference, buffer amplifier, and nine termination resistors (Figure 1). The bandgap reference circuit produces a precise 2.55V

PIN ASSIGNMENT

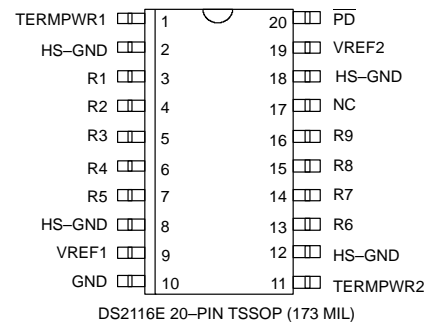

level which is fed to a buffer amplifier. The buffer produces a 2.7V level and is capable of sourcing at least 24 mA into each of the termination resistors when the signal line is low (active). When the driver for a given signal line turns off, the terminator will pull the signal line to 2.7V (quiescent state). To handle actively negated SCSI signals, the buffer can sink at least 200 mA, and V_{REF} will move less than 60 mV. When all lines settle in the quiescent state, the regulator will consume about 2.5 mA. When the DS2116 is put into power-down mode by bringing \overline{PD} low, the power-down circuitry will turn off the transistors on each signal line. This will isolate the DS2116 from the signal lines and effectively remove it from the circuit. The power-down pin (\overline{PD}) has an internal 50K Ω pull-up resistor. To place the DS2116 into an active state, the \overline{PD} pin should be left open circuited. When installed on disk drives or RAID system components, the DS2116 will not affect the SCSI bus during a hot plug operation.

To ensure proper operation, both the TERMPWR1 and TERMPWR2 pins must be connected to the SCSI bus TERMPWR line and both the VREF1 and VREF2 pins must be tied together externally. Each DS2116 requires a 4.7 μF capacitor connected between the VREF pins and ground. Figure 2 details a typical SCSI bus configuration. In an 8-bit wide SCSI bus arrangement ("A"

Cable), two DS2116s would be needed at each end of the SCSI cable in order to terminate the 18 active signal lines. In a 16-bit wide SCSI bus arrangement ("P" Cable), three DS2116s would be needed at each end of the SCSI cable in order to terminate the 27 active signal lines.

DS2116 BLOCK DIAGRAM Figure 1

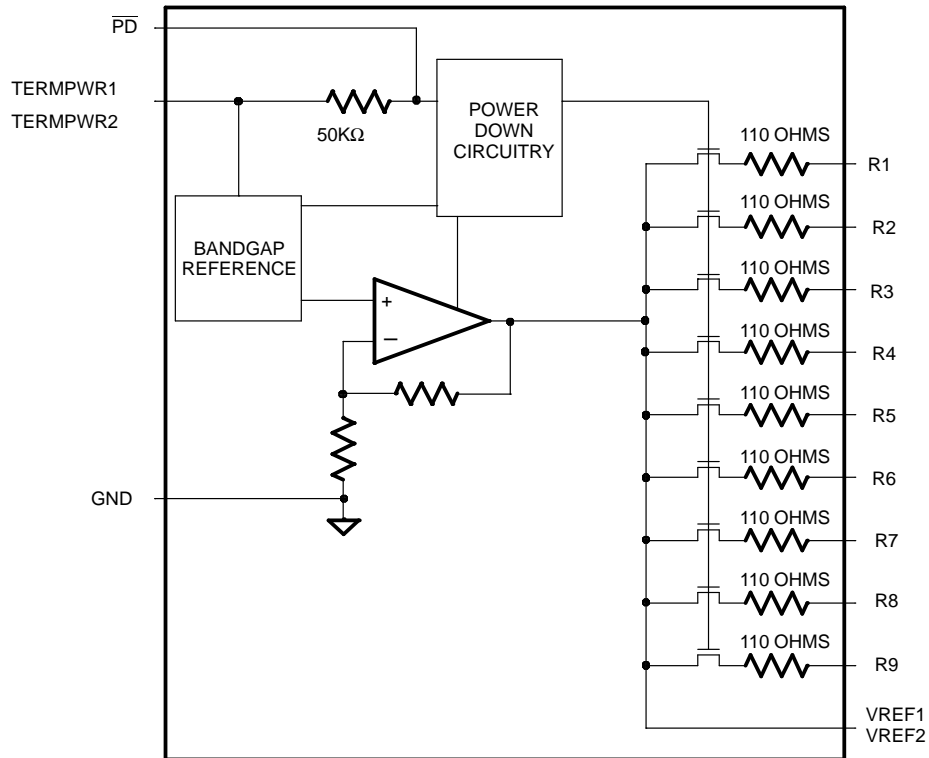

TYPICAL SCSI BUS CONFIGURATION Figure 2

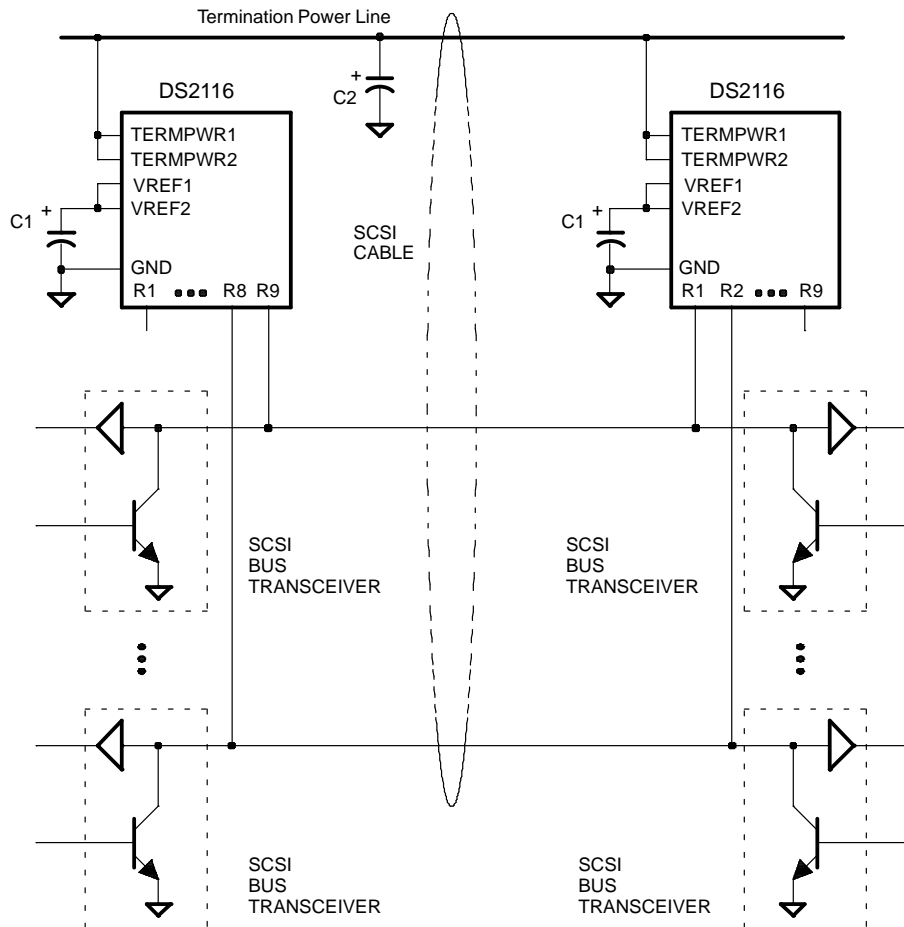
**NOTES:**

1. C1 = 4.7 μ F tantalum
C2 = 2.2 μ F tantalum or 4.7 μ F aluminum
2. If the DS2116 is to be embedded into a peripheral that will act as a target on a SCSI bus, it is that recommended TERMPWR be derived from the SCSI cable, not generated locally. In this configuration, if a power failure occurs in the peripheral, it will not affect the bus.
3. A high frequency bypass capacitor (0.1 μ F recommended) can be added in parallel to C1 for applications using fast rise/fall time drivers.

PIN DESCRIPTION Table 1

DS2116E PIN	DS2116S PIN	SYMBOL	DESCRIPTION
1	1	TERMPWR1	Termination Power 1. Should be connected to the SCSI TERMPWR line. Must be decoupled with either a 2.2 μ F or 4.7 μ F. See Figure 2.
3	2	R1	Signal Termination 1. 110 ohm termination.
4	3	R2	Signal Termination 2. 110 ohm termination.
5	4	R3	Signal Termination 3. 110 ohm termination.
6	5	R4	Signal Termination 4. 110 ohm termination.
7	6	R5	Signal Termination 5. 110 ohm termination.
9	7	VREF1	Reference Voltage 1. Must be externally connected directly to the VREF2 pin. Must be decoupled with a 4.7 μ F capacitor as shown in Figure 2.
10	8	GND	Ground. Signal ground; 0.0V.
11	9	TERMPWR2	Termination Power 2. Should be connected to the SCSI TERMPWR line. Must be decoupled with either a 2.2 μ F or 4.7 μ F. See Figure 2.
13	10	R6	Signal Termination 6. 110 ohm termination.
14	11	R7	Signal Termination 7. 110 ohm termination.
15	12	R8	Signal Termination 8. 110 ohm termination.
16	13	R9	Signal Termination 9. 110 ohm termination.
17	14	NC	No Connect. Do not connect any signal to this pin.
19	15	VREF2	Reference Voltage 2. Must be externally connected directly to the VREF1 pin. Must be decoupled with a 4.7 μ F capacitor as shown in Figure 2.
20	16	$\overline{\text{PD}}$	Power Down. When tied low, the DS2116 enters a power-down mode. Contains an internal 50K pull-up. Strap low to deactivate the DS2116, leave open circuited to activate the DS2116.
2, 8, 12, 18	N/A	HS-GND	Heat Sink Ground. Internally connected to the mounting pad. Should be either grounded or electrically isolated from other circuitry.

ABSOLUTE MAXIMUM RATINGS*

Voltage on Any Pin Relative to Ground	-1.0V to +6.0V
Operating Temperature	0°C to 70°C
Storage Temperature	-55°C to +125°C
Soldering Temperature	260°C for 10 seconds

* This is a stress rating only and functional operation of the device at these or any other conditions above those indicated in the operation sections of this specification is not implied. Exposure to absolute maximum rating conditions for extended periods of time may affect reliability.

RECOMMENDED OPERATING CONDITIONS

(0°C to 70°C)

PARAMETER	SYMBOL	MIN	TYP	MAX	UNITS	NOTES
TERMPWR Voltage	V_{TP}	2.7	3.3	5.50	V	
\overline{PD} Active	V_{PDA}	-0.3		+0.8	V	
\overline{PD} Inactive	V_{PDI}	2.0		$V_{TP} + 0.3$	V	

DC CHARACTERISTICS

(0°C to 70°C)

PARAMETER	SYMBOL	MIN	TYP	MAX	UNITS	NOTES
TERMPWR Current	I_{TP} I_{TP}		2.5	250 5	mA mA	1, 3 1, 4
Power Down Current	I_{PD}		100	150	μ A	1, 2, 5
Termination Resistance	R_{TERM}	96	104	116	Ohms	1, 2
Die Thermal Shutdown	T_{SD}	150			°C	1, 6
Power Down Termination Capacitance	C_{PD}		3.0	5.0	pF	1, 2, 5, 6
Input Leakage High	I_{IH}	-1.0			μ A	1, 8
Input Leakage Low	I_{IL}			1.0	μ A	1, 7

REGULATOR CHARACTERISTICS

(0°C to 70°C)

PARAMETER	SYMBOL	MIN	TYP	MAX	UNITS	NOTES
Output Voltage	V_{REF}	2.5	2.7	3.0	V	1, 2
Drop Out Voltage	V_{DROP}		0.1	0.2	V	3, 6
Line Regulation	L_{REG}		1.0	2.0	%	1, 4
Load Regulation	L_{OREG}		1.3	3.0	%	1, 3
Current Limit	I_{LIM}		350		mA	1
Sink Current	I_{SINK}	200			mA	1

NOTES:

1. $2.7V < \text{TERMPWR} < 3.3V$.
2. $0.0V \leq \text{signal lines} \leq \text{TERMPWR}$.
3. All signal lines = 0.0V.
4. All signal lines open.
5. $\overline{\text{PD}} = 0.0V$.
6. Guaranteed by design; not production tested.
7. R_1 through R_9 only.
8. R_1 through R_9 and $\overline{\text{PD}}$.

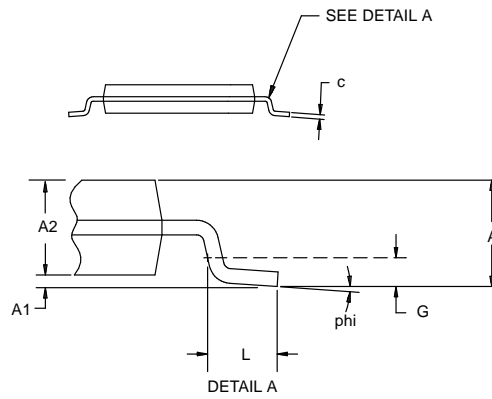
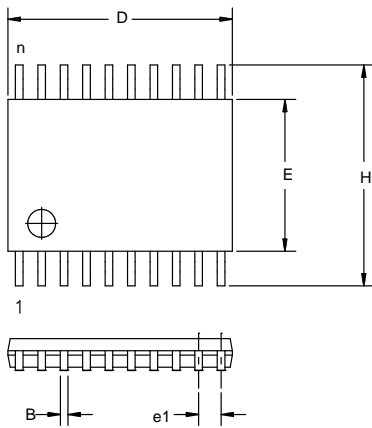
DS2116E SCSI TERMINATOR 20-PIN TSSOP

DIM	MIN	MAX
A MM	–	1.10
A1 MM	0.05	–
A2 MM	0.75	1.05
C MM	0.09	0.18
L MM	0.50	0.70
e1 MM	0.65 BSC	
B MM	0.18	0.30
D MM	6.40	6.90
E MM	4.40 NOM	
G MM	0.25 REF	
H MM	6.25	6.55
phi	0°	8°