

DALLAS SEMICONDUCTOR

Application Note 324 DS2151, DS2152, DS2153, DS2154 Network Interface, Secondary Over-Voltage Protection

The DS2151, DS2152, DS2153, and DS2154 Single-Chip Transceivers are used in applications connecting directly to the outgoing telephone lines and hence the devices can be exposed to hazardous over-voltage conditions. For such applications, protection networks are used to direct high voltage or current away from the more sensitive low voltage CMOS semiconductor devices. The circuitry shown below details how to construct a protection network that provides for both longitudinal (common mode) and metallic (differential) surges as well as for power-line cross. The network described targets compliance with UL1459, FCC Part 68, Bellcore TR-NWT-1089, and ITU K17 - K20.

Figure 1 depicts a circuit using a resistor fuse combination on the line side of the transformer. The fuse protects

the transformer against high current conditions such as power line cross. The value of the fuse is set to match the maximum power dissipation or continuous current rating of the transformer. Contact the transformer manufacturer for this specification. Fuses will typically break at 135% of their rating. This must be kept in mind when selecting the proper fuse. Typically the fuse will have SURGE WITHSTAND rating in the 50 to >100 ampere range. If less than 100 amps, the fuse will have to be protected by a current limiting resistor. The model for what will pass through the primary protection circuit is 800V @ 100A. If the fuse has a SURGE WITHSTAND greater than 100A such as the Littelfuse 2301.25 shown in Figure 2 then current limiting resistors are not needed.

PROTECTION NETWORK Figure 1

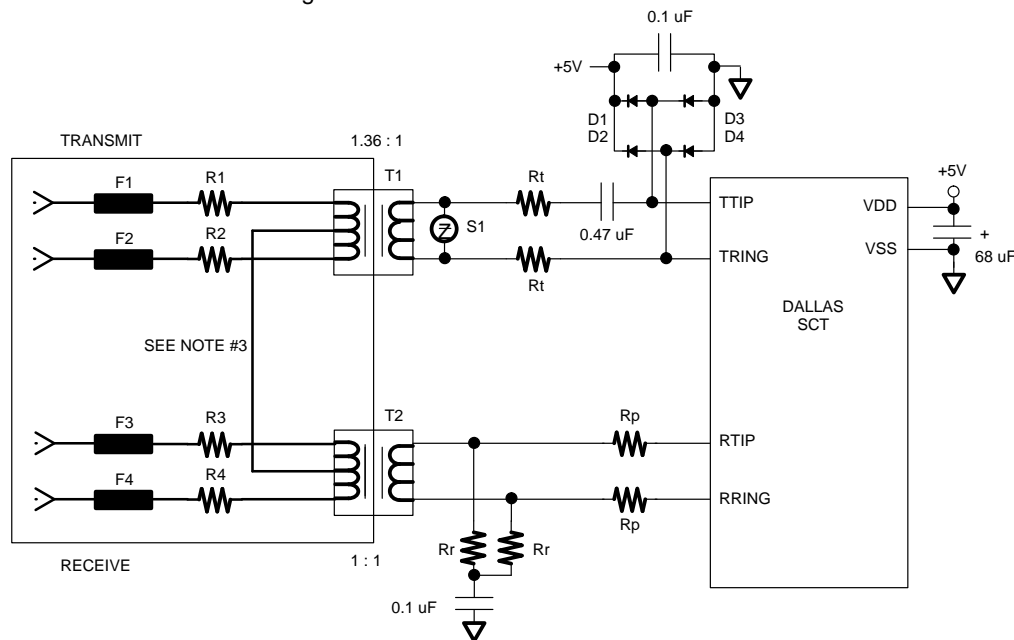

Components

NAME	DESCRIPTION	PART NUMBER	SOURCE
Rr	See Note 1	1/8 watt 1%	
Rp	470Ω	1/8 watt 10%	
Rt	2.2Ω	1/8 watt 10%	
D1 to D4	Signal Diode	1N4148 or equal	
S1	30V Transient Suppresses	P0300EA70	TECCOR
		TPN3021	SGS-Thomson
T1, T2	Transformers	(see Transformer Application Note)	
F1 to F4	Fuse		
R1 to R4	Power Resistor		

NOTES:

1. The value of Rr is determined by the line impedance (75, 100, or 120 ohms) and the value of R3 and R4 according to the following formula: $R_r = [Line\ Impedance - (R_3 + R_4)] / 2$
2. In the boxed-in area, layout is critical. Traces should at least 20 mils wide and be separated from other circuit lines by at least 150mils.
3. Only needed in applications that require a DC path for the transmit and receive paths (i.e. T1 CSU applications).
4. See the Transformer Selection Guide for picking a transformer with the proper isolation.
5. F1 to F4 and R1 to R4 are required to protect the transformer during power-line cross according to UL1459; contact the factory for information on how to chose F1 to F4 and R1 to R4 to meet the application.

PROTECTION NETWORK Figure 2

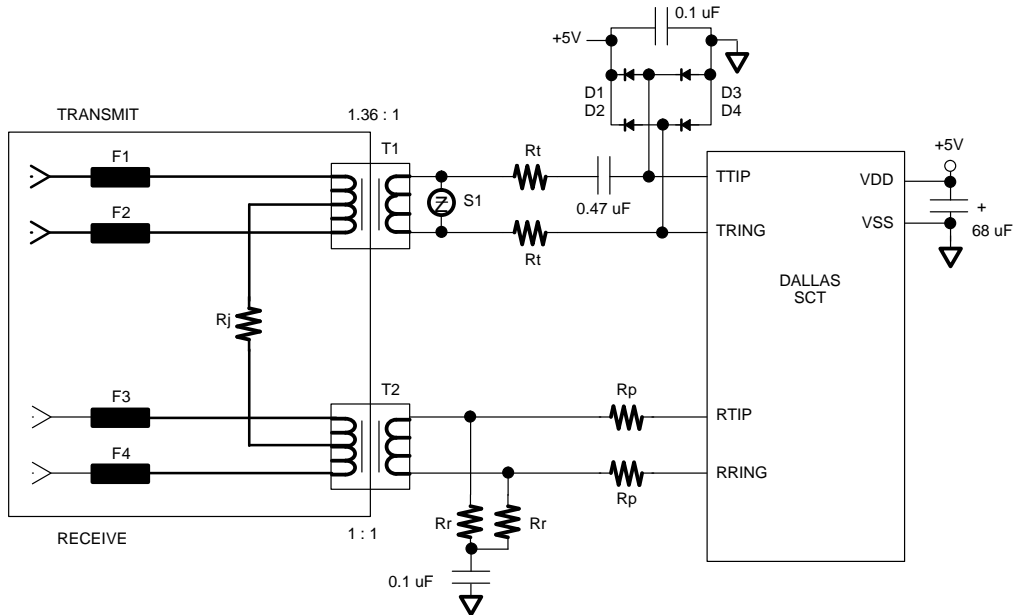

Components

NAME	DESCRIPTION	PART NUMBER	SOURCE
Rr	See Table 1	1/8 watt 1%	
Rp	470Ω	1/8 watt 10%	
Rt	See Table 1	1/8 watt 1%	
Rj	See Table 1		
D1 to D4	Signal Diode	1N4148 or equal	
S1	30V Transient Suppresses	P0300EA70	TECCOR
T1	Transformer 1:1.36CT 3KV Low DCR	PE-65832	Pulse Engineering
T2	Transformer 1CT:2CT 3KV Low DCR	PE-65835	Pulse Engineering
F1 to F4	1.25 Amp Slow Blow Fuse	2301.25	Littelfuse

RESISTOR VALUE SELECTION Table 1

APPLICATION	Rr	Rt	Rj
T1	50	4.7	0
E1 75Ω (L2/L1/L0 = 110)	37	18	open
E1 120Ω (L2/L1/L0 = 100)	60	27	open

NOTES:

- Resistors are not needed to protect the fuse since the fuse can survive the applied surges.
- Transformers with a low DC resistance are needed to allow them to withstand power line cross at the rated fuse limit (times 1.35) without compromising the transformers isolation.
- PE-65835 is a 1:2 ratio overall. Use center-tap to configure as a 1:1.

PTC DEVICES

PTC devices such as the **PolySwitch** from Raychem can be used in place of the resistor-fuse combination as shown in Figure 3. This circuit is shown as an example only and has not been tested by Dallas Semiconductor. The advantage of these devices is that they will "heal" after being exposed to over current conditions and do not need to be replaced as a fuse does. Because PTC devices vary significantly in resistance several considerations must be made when designing with them.

Some devices have a resistance range of 4 to 10 ohms. This variance coupled with the inter-winding capacitance of the transformer can upset the balance of a T1 or E1 line. Manufacturers may offers these devices "BAGGED" to within 1/2 ohms of each other. When used in this manner, the device should not cause excessive line imbalance.

On the receive side these devices become part of the line termination. Any variance, part to part, will directly vary the termination. On the transmit side this variance directly affects the output pulse amplitude as these devices form a voltage divider with the characteristic line impedance.

Another consideration when using these devices is that when broken down (tripped) the first time, the device will recover to a resistance about .8 ohms higher. This new resistance value is called the POST TRIP resistance or POST REFLOW resistance. It is therefore necessary to guarantee that all devices are exposed to electrical or environmental (heat) conditions that are sufficient to cause initial break down during the assembly process.

PTC DEVICES USAGE Figure 3

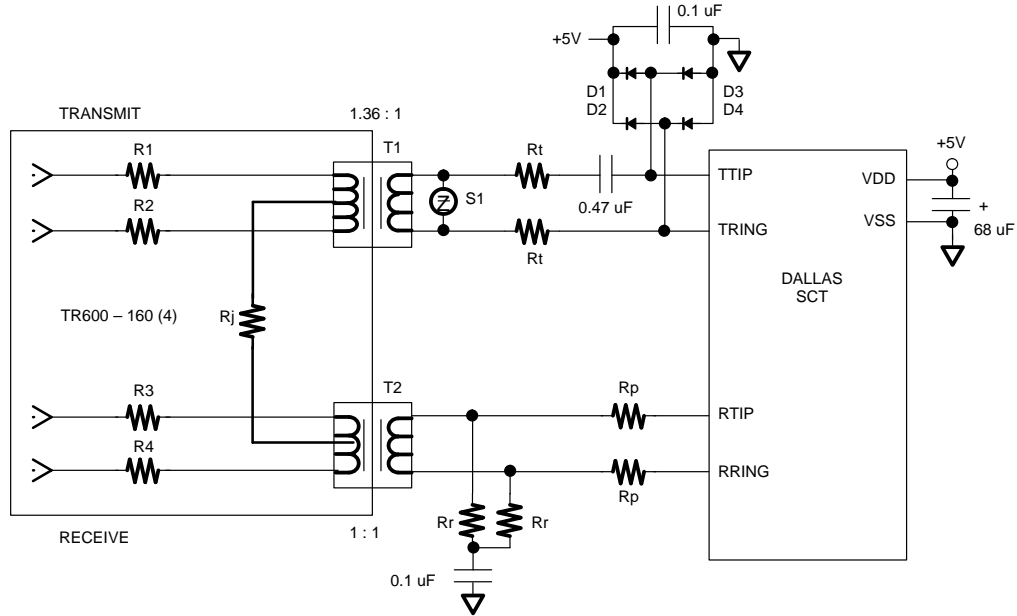

Components

NAME	DESCRIPTION	PART NUMBER	SOURCE
Rr	See Table 2	1/8 watt 1%	
Rp	470Ω	1/8 watt 10%	
Rt	See Table 2	1/8 watt 10%	
Rj	See Table 2		
D1 to D4	Signal Diode	1N4148 or equal	
S1	30V Transient Suppresses	P0300EA70	TECCOR
T1	Transformer 1:1.36CT		
T2	Transformer 1CT:1CT		

RESISTOR VALUE SELECTION Table 2

APPLICATION	Rr	Rt	Rj
T1	50-Rpt	4.7 - (Rpt/n ²)	0
E1 75Ω (L2/L1/L0 = 110)	37-Rpt	18 - (Rpt/N ²)	open
E1 120Ω (L2/L1/L0 = 100)	60-Rpt	27 - (Rpt/N ²)	open

N = Turns Ratio of Transformer (Line Side / Device Side) PolySwitch is a registered trademark of Raychem Corp.

Rpt = Post Trip resistance of PTC device