

PRODUCT DATA

Ometron Scanning Laser Doppler Vibrometer — Type 8330

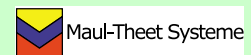

Ometron Scanning Laser Doppler Vibrometer (SLDV) Type 8330 is a highly accurate, compact and versatile, non-contact vibration transducer for applications where it is impossible or undesirable to mount an array of vibration transducers on a vibrating object. It is a full-field system that quickly produces vibration maps depicting the structural response at multiple measurement points. In such applications, the Type 8330 SLDV can often replace an array of accelerometers or microphones.



8330

- USES**
- Experimental modal analysis
 - Inspection of operating machinery
 - Structural integrity assessment studies
 - Analytical modelling
 - Validation of FE models
 - Noise control
 - Non-destructive inspection
 - Quality assurance
 - Conditioning monitoring
 - Design studies
 - Production assembly techniques

- FEATURES**
- Portable size (24 × 38 × 24 cm) and weight (15 kg)
 - Compact design consisting only of sensor head and PC
 - Velocity range from 0.5 μm/s to 2 m/s peak-to-peak
 - High optical sensitivity through homodyne optical/electronic principle
 - Surface treatment not normally required, even on dark/black surfaces
 - Easily handles small object - small distance, or large object - large distance situations
 - Lenses for working ranges from 50 mm to 200 m provided as standard
 - High-resolution, 16-bit digital mirror drive offering angular steps of less than 1 milli-degree
 - Digitally controlled Moving Magnet Galvo motors practically eliminate position hysteresis
 - Full-colour, in-line Charge Coupled Device (CCD) camera avoids possible parallax errors in background wallpaper
 - Dropout detection for fast re-scanning of positions with low signal-to-noise ratio
 - Self-sensing or Universal Power Supply Unit can operate in any environment with 85 – 240 V AC, 50/60 Hz
 - Unique, self-diagnostic tools give quick turn-around time in the unlikely event of a service call
 - User-friendly, Windows NT[®]-based software with built-in, high-end FFT analyzer
 - Easy interface to standard Operational Deflection Shapes (ODS) and optional Modal Analysis and multi-shaker (MIMO) software packages
 - Export of data and results in UFF and ASCII file formats
 - High-resolution scanning of wallpaper dispenses with need for mechanical zooming tools
 - Extensive tools for creating and editing geometries and grids of measuring points
 - 3D-animation of the wallpaper picture for lively presentation of ODS and Modal Analysis results
 - Brüel & Kjær's renowned, comprehensive, worldwide consultation, training and after-sales support offered to all users
 - Standard, low-cost inter-connection cables between sensor head and configured PC – easily replaced by local, electronic parts suppliers

Introduction

Type 8330 SLDV is a turnkey system that includes all the optical/electronic hardware (and accompanying software) necessary to obtain and represent most global, field vibration parameters. For those users with more demanding requirements, additional, optional software packages can provide result presentations related to multi-shaker excitation (MIMO) and/or advanced modal analysis.

Based upon a safe and visible Class II laser, the system avoids the need for special safety facilities or protective equipment. The compact size and low weight of the system offer a portability that makes it suitable for both laboratory and field work.

Type 8330 SLDV is an updated version of the Ometron VPI-4000 (Vibration Pattern Imager) scanning vibrometer, coming with improved digital mirror control, a full-colour CCD camera, and a higher velocity range. Type 8330 also features a built-in, self-sensing power supply, a vibration analyzer card (inserted in the PC), and new, Windows-NT based, vibration analysis software developed by Maul-Theet Systeme.

Design – Optics

Fig. 1
Type 8330 SLDV
optical layout

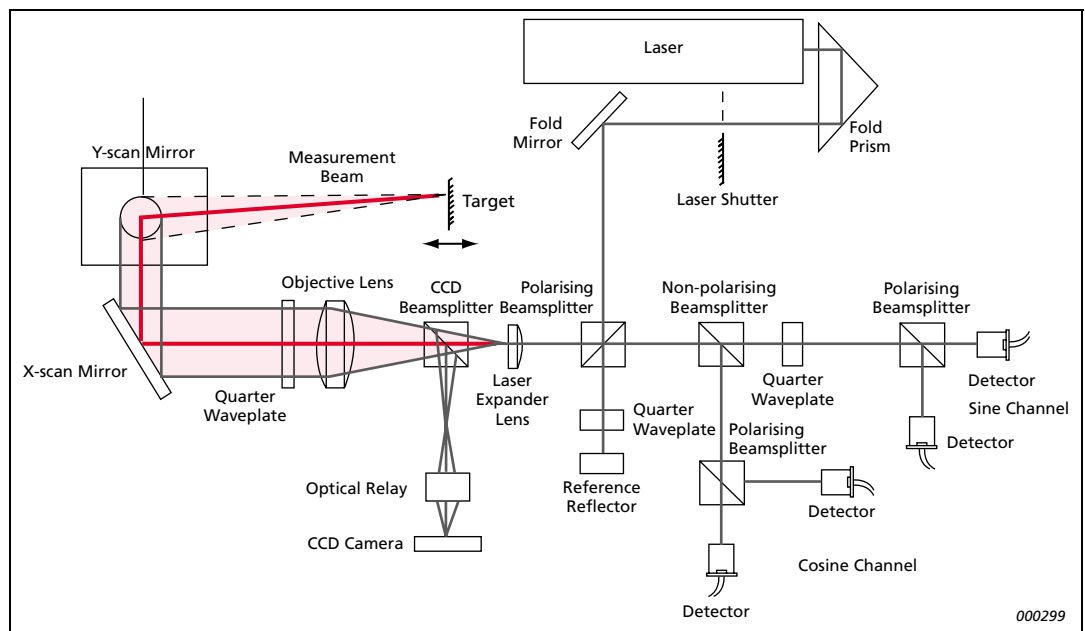

The optical sensor of the Type 8330 SLDV is based on a Michelson interferometer in which a laser beam is divided into a reference and a signal beam. The signal beam is directed onto a vibrating test surface, and the back-reflected light recombined with the internal reference beam.

When the test surface moves, the path difference between the routes followed by the reference and signal beams changes, resulting in light intensity modulation of the recombined beam due to interference between the reference and signal beams. One complete cycle of the light intensity modulation corresponds to a surface movement of $\lambda/2 = 3.16 \times 10^{-7}$ m, i.e., half the wavelength of the Helium-Neon laser source. Hence, the frequency, F_d , of the intensity modulation corresponding with a velocity, v , is given by $F_d = 2v/\lambda$, where F_d is the "Doppler frequency" associated with a surface velocity, v .

The intensity modulation of the recombined beam may alternatively be seen to arise from the interference between a reference beam and a signal beam. The frequency of the latter is shifted by an amount, $F_d = 2v/\lambda$, in accordance with the Doppler effect, following reflection from a surface moving with a velocity, v .

The recombined beam is shared between two independent detection channels in such a way that the interferometric path difference presented to one channel is effectively one quarter of a wavelength longer than that presented to the other channel. This configuration results in a 90° phase shift between the signals from the two channels. The direction of surface motion can thus be determined by looking at which signal leads the other in phase. The sine and cosine signals at frequency F_d are fed to a dual-channel balanced modulator where they are respectively modulated by internally generated sine and cosine signals at a carrier frequency F_c .

Summation of the two modulated outputs described above yields a single, frequency-shifted output at $F_c + F_d$ or $F_c - F_d$, depending on the direction of surface motion. In this way, electronic mixing results in essentially the same frequency-shifted Doppler signals as those obtained using optical frequency techniques.

Design – Electronics

Established methods are used to derive the analogue voltage that represents the moving surface's instantaneous velocity at the spot where it is hit by the laser beam.

Fig. 2
Block diagram of
Type 8330 SLDV
electronics

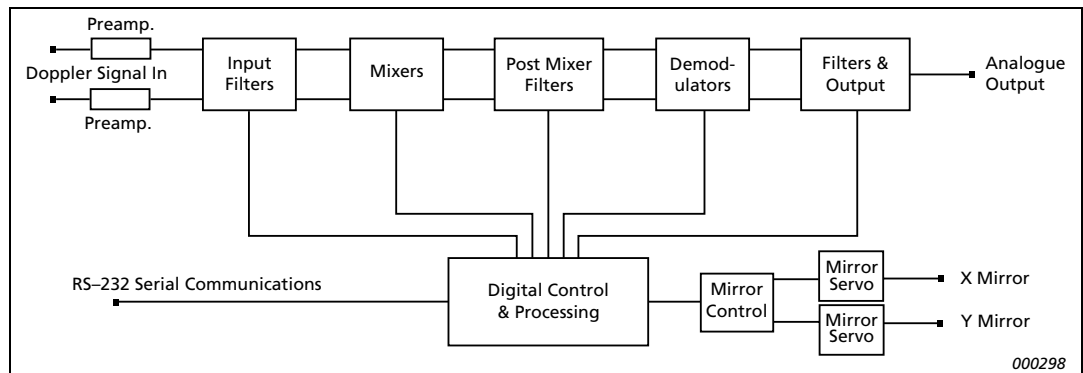

Preamplifiers

In the preamplifier stage, the current from each pair of photodiode detectors is converted into a voltage by a wide-band, low-noise amplifier in a screened environment. This voltage is then driven to an input-filter stage. It is actually in the preamplifier stage that the optical signals are turned into electronic signals, which are also known as "Doppler Signals".

Input Filters

The input filter removes high-frequency noise and, by aliasing in the following mixer stage, ensures that the Doppler frequency, which is directly proportional to the surface velocity, remains below the carrier frequency in the mixer.

Mixer

A digital mixing technique is used at this point to implement the equation:

$$\cos(A - B) = \cos A \cos B + \sin A \sin B,$$

where A is the carrier and B is the Doppler signal.

Post-mixer Filter

High-order, low-pass filters are used (depending on range) to remove unwanted harmonics.

Demodulation

The demodulation stage converts frequency to voltage. This is achieved by using an averaged-time, pulsed technique which gives a very linear conversion.

Output Filter

A maximum 3-pole, 2 MHz (or 5-pole, 200 kHz – depending on range) flat filter is used to smooth out signals from the demodulation stage and remove any unwanted high-frequency noises.

Digital Control and Processing

The sensor head is connected via a RS-232C serial interface to one of the available COM-ports of Configured PC UL0179.

The digital control and processing function of the electronics takes care of a number of control functions:

- Setup of the five velocity ranges
- Operation of the full-colour CCD camera
- Positioning of the two 16-bit, digitally controlled mirrors
- Supervision of the velocity data and signal flow from pre-amplifier to analogue output
- Opening and closing of the electromagnetic laser beam shutter during wallpaper scanning
- Advanced diagnostics to facilitate ease of repair

Power Supply

All electronic and electrical parts in Sensor Head SB2507 are provided with power from a universal, self-sensing power supply that will operate in any environment with 85 – 240V AC, 50/60 Hz.

Optical Units, Accessories and Options

Sensor Head

The SLDV Sensor Head SB2507 consists of a rugged optical frame of which mounting fixtures for the mirror form an integral part. This ensures that the internal optical path is not affected by the mounting of the sensor head.

The sensor head includes all the optical parts necessary to form a Michelson interferometer, as well as two (X and Y) 16-bit, digitally controlled mirrors that have an angle resolution of $10.65 \mu\text{Rad}$ or 0.0006102° . This results in minimum step sizes of approximately $0.5 \mu\text{m}$ at 50 mm with the short-range lens, or 0.5 mm at 50 m with the long-range lens (see Lenses section on next page).

For users who would like to have full control over a scanning vibrometer sensor head by adding their own vibration analyzer front-end, as well as their own control and analysis software, it is possible to purchase Sensor Head SB 2507 separately. However, Brüel & Kjær cannot guarantee that the specifications quoted in this Product Data will be valid for any combination of sensor head and controller/analyzer not included in the Brüel & Kjær product range.

Fig. 3
Lens kit for
Type 8330



Lenses

The sensor head is provided with two lenses (35 mm short-range and 95 mm long-range), each having its own range of working distances (50 – 5000 mm (2 – 200 in.) and 1 – 200 m (1 – 220 yards) respectively). Interchanging the lenses accordingly influences the focusing depth and working distance of the SLDV.

It is recommended that the long-range lens be used in applications involving dark surfaces at working distances of 1 – 5 m, in order to obtain more light from the target.

The lens is mounted in the sensor head behind a sliding cover for dust protection. You can change it within a minute or so and without affecting the calibration of the system.

Fig. 4
Type 8330 with
Type 8329 for
reference signal



Laser Doppler Vibrometer Type 8329

For situations that do not allow the fixture of a reference transducer, Brüel & Kjær recommends the use of the single-point Laser Doppler Vibrometer Type 8329, e.g., in ODS experiments on very light and/or small structures.

Vibration Analyzer Accessories and Options

Configured PC

To avoid system integration problems that place demands on time and resources, Brüel & Kjær strongly recommends purchase of the configured PC together with the sensor head.

Configured PC UL0179 consists of the following main components:

- A PC with ≥ 733 MHz (minimum) Intel Pentium III CPU, ≥ 256 MB RAM, ≥ 20 GB HDD, a CD-ROM/RW drive and a 100 MB/s Ethernet, PCI-bus LAN card
- 4-channel, 20 kHz/ch. DSP card (PCI) ZD 0860
- Framegrabber (PCI) ZE 0853
- OpenGL graphics card with ≥ 32 MB RAM (AGP) ZE 0852
- Short-length cable set (5 m) AO 0582

The specifications of the configured PC follow the general trend in the development of the worldwide PC market and are therefore subject to change.

4-channel, 20 kHz (per channel) DSP (FFT) Card

This is the vibration analyzer, PCI-based DSP card (ZD0860) that comes as standard with Type 8330 SLDV.

The card has 4 channels of analogue input. One channel will always be connected to the analogue velocity output of the sensor head. The remaining three channels can be connected to the reference accelerometer or force transducer of up to three shakers. The two on-board, Digital-to-Analogue Converters (DACs) can be used to independently control two shakers with (swept) sine, random, triangle, rectangular (pulse) or chirp signals. This feature is especially useful if used with the Multi-shaker excitation and MIMO Analysis Software option BZ5319.

Fig. 5
4-channel, 20 kHz
(per channel) PCI-
based DSP (FFT)
card ZD0860



2-channel, 80 kHz (per channel) DSP (FFT) Card

For high-frequency vibrations exceeding 20 kHz, a 2-channel, 80 kHz card ZD0589 can be used.

This card is similar in specification to the 4-channel, 20 kHz card with the exception of the number of channels and the fact that the two DACs are missing so that it is NOT possible to control two shakers in a multi-shaker MIMO vibration analysis from within the standard control and analysis software.

If specified with the initial order, the 2-channel, 80 kHz card can be installed in the PC/analyzer instead of the 4-channel, 20 kHz card without additional cost.

250 kHz Correlator

For applications which encounter extremely high vibration frequencies of up to 250 kHz from a target surface, Brüel & Kjær offers a solution with an external correlator for the external lock-in input of Type 8330's Sensor Head – EG & G 250 kHz correlator UA1579 (including accessories). This option adds one unit to your scanning laser vibrometer system and is available at an additional cost. The correlator is connected to the PC via an IEEE-488 interface card and cable. This interface and a software driver (UA1580, including IEEE card and cable) are ordered separately.

Mounting and Transport Options

Fig. 6
Tripod, including a multi-directional head, UA 1577



Tripod

As the SLDV measures the relative motion between the sensor and the target, it is important that the sensor head is placed on a tripod that can absorb disturbing environmental vibrations. The optional tripod offered by Brüel & Kjær (Tripod UA 1577, including multi-directional head) is very rugged and designed to carry television-studio cameras.

Transit Cases

For the purposes of transport and storage of the SLDV, a set of two transit cases are available:

- KE 1004 Transit Case for Type 8330 SLDV Sensor Head
- KE 1005 Transit Case for Type 8330 SLDV PC

These are manufactured from vacuum-formed ABS plastic and come with hinges, two recessed handles and two recessed catches/locks. These cases protect the delicate optical sensor head and PC during road and airfreight transport.

The foam interior of one transit case has cavities for the sensor head and all its accessories, as well as all accompanying cables. The cavities in the second case are designed to take the PC, keyboard, mouse and their accompanying cables (but not the monitor).

Software Accessories and Options

Control and Analysis Software

Control and Analysis Software BZ 5310 is the default software package that comes with Type 8330 SLDV and is pre-installed on the configured PC (UL 0179). The control aspect of the software takes care of the instrument setup, e.g., velocity range settings and filter settings, as well as the positioning of the two mirrors. The data flow during data acquisition is also controlled by this part of the software. The analysis aspect of the software takes care of the setup of the measuring point grid/mesh and the calculation of all common vibration parameters, as well as the presentation and animation of results.

A "Measurement Assistant" has been written into the software to aid operation of the instrument by guiding you through all required steps. An easy-to-use CCD correction tool allows you to obtain 100% coherence between the laser beam and the wallpaper picture, while geometric data (such as points, lines and surfaces) can be exported in UFF and ASCII formats.

The analyzer has auto-range for all inputs, RMS in the time and frequency domains, plus FFT and Lock-In modes. Complex ODS results can also be exported in UFF and ASCII format.

The analyzer section of the software can calculate a number of vibration parameters and display them in different ways (see Specifications).

Advanced Modal Analysis Software Upgrade

Advanced Modal Analysis software BZ 5318 is an optional software package which, if installed, fully integrates into the Control and Analysis software package and enables you to calculate and present a number of modal analysis parameters not originally included in that package. Data and result files can be exported in UFF or ASCII formats. For further information, see Specifications.

Multi-shaker Excitation and MIMO Software Upgrade

Multi-shaker Excitation and MIMO Analysis software package BZ 5319 is an optional software package that enables you to calculate and present a number of modal analysis parameters related to exciting the target area with more than one shaker. For further information, see Specifications.

SLDV for Users with a Vibration Analyzer running with I-DEAS software

MasterScan™ for Vibration Analyzers running under I-DEAS™ from MTS

For those who already have a multi-channel vibration analyzer running with I-DEAS software, Brüel & Kjær offers a solution where an existing analyzer can form an integral part of the scanning laser vibrometer. This makes it unnecessary to purchase the configured PC/analyzer and the standard vibration analysis software. It should be kept in mind that the specifications of such a scanning vibrometer system depend greatly on the specifications of the existing vibration analyzer. To configure a complete scanning laser vibrometer, you need Sensor Head SB 2507 and one of the following MasterScan I-DEAS software drivers for control of the sensor head, (including the mirrors):

- BZ 5313 MasterScan 8330-7 (for I-DEAS version 7)
- BZ 5312 MasterScan 8330-8 (for I-DEAS version 8)
- BZ 5311 MasterScan 8330-9 (for I-DEAS version 9)

Upgrade Kits for Previous Models of Ometron Scanning Vibrometers

It may be possible for those with an earlier version of the Ometron scanning laser vibrometer (models VPI or VPI-4000) to upgrade their systems to a standard close to that of Type 8330 SLDV. You can find out by contacting your nearest Brüel & Kjær representative and providing them with the type and serial numbers of the units that form your current Ometron scanning laser vibrometer, plus information on whether your current system has the optional CCD camera fitted. We will then return with an offer of a turnkey upgrade of your scanning laser vibrometer, which consists of an upgrade kit for the current sensor head and a Configured PC UL0179 for Type 8330. See Specifications for more details.

Measurement Setup

ODS Measurements

One of the simplest setups for Type 8330 SLDV is that for Operational Deflection Shape measurements. One of the inputs of the DSP board in the PC is used for the reference signal from, e.g., a Constant Current Line Drive (CCLD) accelerometer transducer. The

second signal to be connected is that of the analogue velocity output of Sensor Head SB 2507. If a shaker is used for excitation of the target surface, the excitation signal from the DAC of the DSP board can be directly looped to the reference input of the DSP board.

Fig. 7 .
Setup for ODS measurements

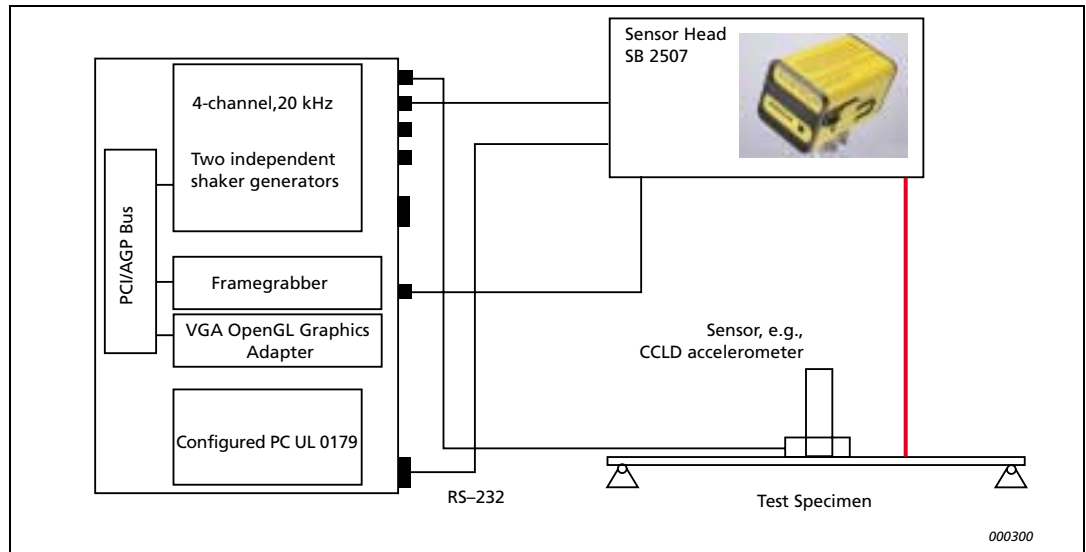

Modal Analysis

To calculate and present the mode shapes of a structure, the signal coming from a force transducer mounted at the point where the shaker is fixed to the target surface is connected to the reference input of the DSP board in the PC. A second input channel is connected to the analogue velocity output of the sensor head. One of the DACs on the 4-channel DSP board acts as a shaker controller and its analogue output is connected to the input of the shaker power amplifier.

Fig. 8
Set-up for Modal Analysis measurements

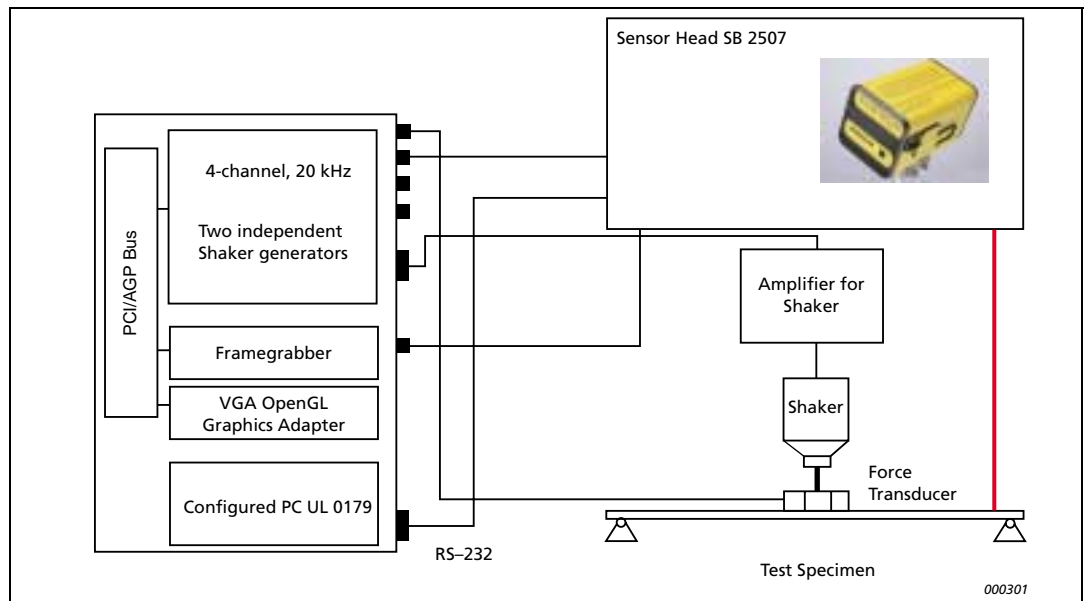

Multi-shaker Excitation and MIMO

This type of measurement is characterised by the fact that two or more shakers contribute to the excitation of the structure. The two shakers can be completely independent, controlled by the two DACs on the 4-channel DSP card. The reference signals from the two force transducers are connected to two of the inputs of the 4-channel DSP board. A third channel is connected to the analogue velocity output of the sensor head. There is still one input channel left, which can be used for the reference signal from

the force transducer of a third shaker. With phase-independent, random-signal excitation, this third shaker can be externally controlled.

Fig. 9
Setup for multi-shaker excitation and MIMO

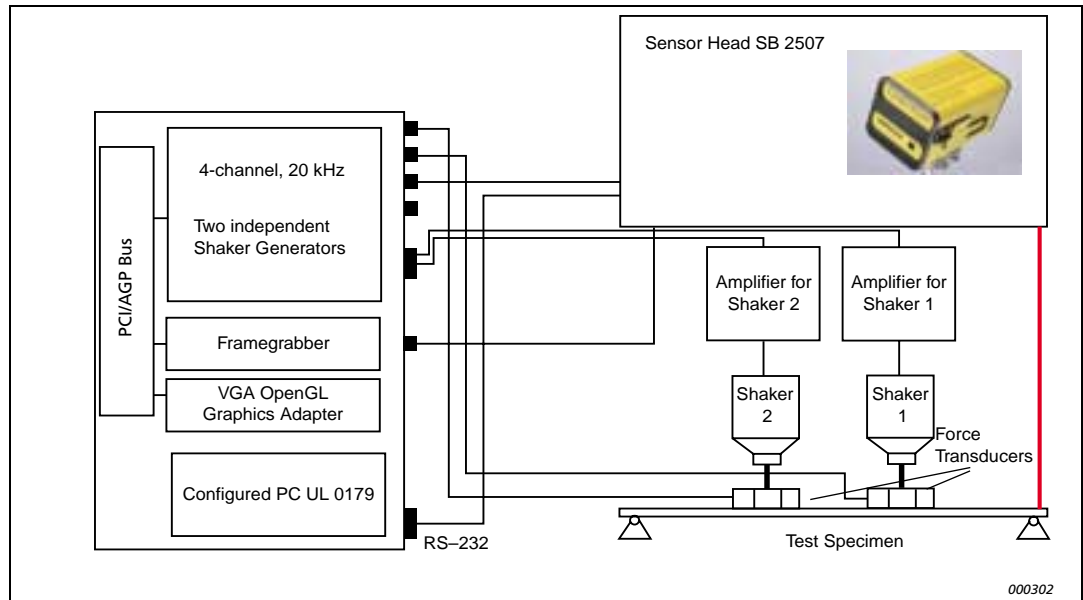

Calibration

The factory adjusts the analogue velocity output of the sensor head to a sensitivity of $\pm 5 V_{\text{peak}}$ for the maximum velocity in each of the 5 velocity ranges: 5, 20, 100, 500 and 2000 mm/s

The resulting output sensitivity for each of the ranges can be found in the specifications of the sensor head.

Each product is delivered with a "Certificate of Traceable Calibration" from the manufacturer, which certifies that each product has been checked and calibrated against test procedures. The test procedures are listed on the certificate.

Cables, Connectors and Power Supply

Cables

The complete Type 8330 SLDV configuration consists of only two main units: a Sensor Head SB 2507 and a Configured PC UL 0179, including the vibration signal analyzer and the analysing and presentation software. The only cables required are standard low-cost coaxial cables, mains cables, a video cable and a serial RS-232C cable. The instrument is supplied with 5 m cables between the sensor head and the configured PC. This covers most laboratory situations. For applications where the sensor head has to be placed farther away from the configured PC, optional cable sets with 10 m and 20 m cable lengths are available. Please contact your nearest Brüel & Kjær office if your application requires a distance larger than 20 m between the sensor head and target.

The available cables are:

- AO 0582 Short cable set (5 m), default
- AO 0583 Medium length cable (10 m)
- AO 0584 Long cable set (20 m)

Signal Output Connectors

Sensor Head SB 2507 is provided with a number of connectors at the rear panel of the instrument:

- Analogue Velocity Signal – A test surface moving towards, or away from, the SLDV sensor head generates, respectively, a positive or negative analogue signal that is directly proportional to the velocity in the direction of the laser beam at the point where the laser beam hits the surface. A test surface moving away from the sensor head will generate a negative analogue velocity signal. The maximum output voltage is $5V_{\text{peak}}$ for the maximum velocity in each of the 5 ranges. The output sensitivity is factory calibrated according to a traceable calibration procedure. This analogue velocity signal is the main signal that is sent to the vibration analyzer.
- D1 and D2 – The sockets D1 and D2 are the Doppler signals monitoring the basic analogue interferometer signals. D1 and D2 show the modulation at a frequency directly proportional to the instantaneous velocity of the test surface. The relationship between frequency and velocity output is 3.16 MHz per m/s. Taken together, D1 and D2 permit the determination of the velocity direction of the measured velocity component parallel to the laser beam: D1 leads or lags D2 by 90° in phase, depending on whether the surface is moving towards or away from Type 8330's sensor head.
- Drop-out Detection – The electronics in Sensor Head SB 2507 detect when the signal-to-noise ratio of the incoming Doppler signal is so poor that reliable measuring results can no longer be expected. This could be the case at a node point where movement of the structure becomes undetectable in the current velocity range, or where overload of the vibration analyzer input causes voltage clipping, or too low an input signal for the analyzer results in unnecessarily low measuring accuracy due to the limited number of bits used in the A/D converter. In such cases, a TTL signal at the Drop-out output will indicate to the software that measurements should be repeated at these points, with or without new settings of the sensor head. The software facilitates automatic re-scanning at these points.
- Video Out – The video output signal of the sensor head carries the video signal representing the wallpaper picture and is connected to the Framegrabber in the PC by means of a video-type coaxial cable.
- Serial output – The RS-232C serial output is used to send information on the sensor head setup back to the configured PC.

Signal Input Connectors

- Serial Input – For the setup of the instrument and advanced diagnostics, an RS-232C serial cable takes care of the signal flow between the sensor head and the configured PC.
- Shutter – In order to avoid disturbance of the bright light spot at the point where the laser beam hits the test structure, a laser shutter that is controlled by the software in the PC, interrupts the laser beam during the scanning process of the wallpaper. This prevents strong red light from the laser beam, which would otherwise be reflected by the target surface, from entering the optics and overshadowing the colour information of the wallpaper picture.

Fig. 10
Sensor Head
SB2507 showing
side-panel with
connectors



Power Supply

The sensor head has only one built-in, universal, self-sensing power supply that can work on any voltage from 85 – 240 V AC, 50/60 Hz. The power supply for the PC will follow the standard defined by the PC manufacturer. If not self-sensing, the PC is provided with a selectable, universal power supply.

Fig. 11
Rear and side-
panel view of
Sensor Head
SB2507



Focusing

On the side-panel of the sensor head, there is a focusing knob to help focus the laser beam on the target structure. The focusing quality can be optimised while observing an LED bar graph just above the knob.

Applications

Scanning vibrometers have typically been used for various applications within a number of industries, including automotive and aerospace. Ometron, in partnership with Maul-Theet, has added advanced modal analysis to its already impressive Operational Deflection Shapes features.

The main applications of the SLDV within the automotive and aerospace industries include:

- Structural analysis of car/aeroplane bodies and frames (chassis)
- Vibration analysis of car doors, wing profiles, etc.
- Wind-induced vibration and sound studies of (parts of) cars in wind tunnels
- Sound emission studies on jet-engines (gas turbines) and IC-engines
- Vibration and shriek analysis of rotating parts, such as tyres, brake systems and engine belts
- Vibration analysis of hot components, such as manifolds and exhaust pipes
- Vibration studies of light-weight structures, such as ducts and fuel pumps

Other interesting SLDV applications include:

- Non-destructive and non-invasive quality testing of cracks and other damage in materials, e.g., castings
- Loudspeaker, microphone and telephone testing
- Vibration testing of consumer goods like power tools, dishwashers, washing machines and dryers
- Vibration and damping measurement of hard disk drive components
- Investigation of the structural dynamic behaviour of complex structures

- Dynamic-response measurements on models of civil structures, such as dams, towers, bridges and high-rise buildings
- Investigation of machine-tool vibrations or chatter

Some more, unusual applications include:

- Measurement of damage to frescoes, paintings and icons in, e.g., churches
- Measurement of middle-ear ossicular vibration patterns for direct-drive, implantable hearing systems
- Investigation of the body vibrations of musical string-instruments

Compliance with Standards

CE	CE-mark indicates compliance with: EMC Directive and Low-Voltage Directive
Safety	EN 61010– 1 and IEC 61010– 1: Safety requirements for electrical equipment for measurement, control and laboratory use
Electromagnetic Compatibility	EN 61326– 1 and IEC 61326– 1: Electrical equipment for measurement, control and laboratory use – EMC requirements CISPR 22: Radio disturbance characteristics of information technology equipment. Class B limits FCC rules, Part 15: Complies with the limits for a Class B digital device
Laser Safety	21 CFR 1040.10, 21 CFR 1040.11: FDA regulations for laser products EN 60825– 1 and IEC 60825– 1: Safety of laser products

Specifications – Scanning Laser Doppler Vibrometer Type 8330

Sensor Head SB 2507

Velocity ranges, frequency ranges and velocity output sensitivity:

Output Range		Output Sensitivity	Output Bandwidth
Minimum	Maximum		
μms^{-1}	mms^{-1}	Vm^{-1}s	kHz
1	5	1000	200
4	20	250	200
20	100	50	200
100	500	10	2000
400	2000	2.5	2000

Laser: He-Ne continuous wave laser, < 1 mW output power, 632.8 nm (red light)

Laser safety: Class II

Noise Floor: < 0.4 $\mu\text{m}^{-1}/\sqrt{\text{Hz}}$ @ the midband of 12.5 kHz

Lenses: Short-range (35 mm) and long-range (95 mm) lenses included

Working distance: With short-range lens from 50 mm (2 inches) to 5 m (16 feet). With long range lens from 1 to 200 m (1 to 220 yards). Dependent on surface finish

Spatial resolution: Approximately 1 mm (0.039 inch) at 20 m (65 feet) working distance

Drop-out detection: for fast re-scanning of points with low S/N ratio or otherwise unreliable data

Accuracy of the analogue velocity output signal: Better than 1%

Velocity polarity: Positive analogue velocity signal when the test surface is moving toward the sensor head of Type 8330 SLDV and a negative signal if the test surface is moving away.

Doppler signal demodulation principle: Homodyne

Two (X+Y) 16-bit, digitally controlled mirrors with:

- **Scan angle:** 25° × 25° field of view
- **Scan resolution:** 10.65 μRads , i.e., 0.0006102°, allowing 0.5 μm between steps at 50 mm working distance and 2 mm between steps at 200 m working distance
- **Scanning speed:** > 50 points per second, while collecting data (frequency dependent)

CCD camera: Full colour, in line with the laser (no parallax errors)

Laser shutter: prevents the laser light from disturbing the wallpaper picture

Resolution of wallpaper picture: Depends on distance between Sensor Head SB 2507 and target surface. Typical 800 × 800 pixels at 400 mm distance and 1500 × 1500 pixels at 3 m distance

Outputs: Analogue velocity output ($\pm 5\text{V}$, 50 Ω), Analogue Doppler signals 1 and 2 in quadrature ($\pm 5\text{V}$, 50 Ω), Drop-out detection (TTL compatible) and CCD camera composite video

Interface: RS-232C for sensor control (including shutter and mirrors), status monitoring and advanced diagnostic tools

Remote control from PC: Mirrors, velocity range and laser shutter

Manual control: Laser beam focus

Configured PC UL0179 (Velocity Signal Analyzer)

Tower PC with monitor, keyboard and mouse: Pentium III 733 MHz CPU, 256 MB RAM, 20 GB HDD, 1.44 MB FDD, CD-ROM and CD-RW drive

4-channel, 20 kHz/channel DSP (FFT) card:

- Bits ADC per channel: 20
- Max. input voltage: $\pm 10\text{V}$
- Input signal bandwidth: 23 kHz
- Inputs: Direct, CCLD (individual for all channels)
- Coupling: AC, DC (individual for all channels)
- Anti-aliasing filter: > 200 dB/Oct slope, ripple < $\pm 0.01\text{ dB}$
- Dynamic range: > 100 dB
- Phase accuracy: better than 0.1°
- Sensor power supply: 4 mA @ 18–32 V DC, selectable for each input
- Maximum resolution of FFT: 6400 lines
- Minimum resolution of FFT: 100 lines
- Input for RPM (tacho) signals from rotating machinery:

Input signal level: 0–25 V

Pulse duration measurement resolution: < 40 ns

Trigger levels: Programmable

Signal generators for shaker excitation (for 4-channel card only):

- Two totally independent signal generators enabling uncorrelated, random signal outputs
- Each output has signal conditioning and direct connection
- Each output with one 16-bit DAC, synchronised with ADC clock
- Max. sinusoidal frequency per channel: 20 kHz
- Max. output voltage: $\pm 10\text{V}$
- Type of output signal: Sine, Random, triangle, rectangle (pulse) and Chirp

For more specifications, contact your nearest Brüel & Kjær representative

FrameGrabber card: PCI bus-based, Imaging Source DFG/LC1

OpenGL graphics card: PCI bus-based, ATI Rage 128, XPERT 2000

Ethernet LAN card: PCI bus-based, 100 MB/s

Note: The specifications of the velocity signal analyzer change over time with developments in the PC market and PC accessories.

Please ask your local Brüel & Kjær representative to inform you about the latest PC configuration

Control and Analysis Software BZ 5310

Operating system: Windows NT (32-bit)

Format of exported data files: UFF or ASCII

The analyzer section of the software can calculate and flexibly display the following vibration parameters:

- Time
- Weighted time
- Fourier Spectra (FFT)
- Auto-power Spectrum (APS)
- Cross-spectra
- Coherence
- Frequency Response Function 1
- Frequency Response Function 2
- Frequency Response Function 3
- KB-weighted
- RMS
- Magnitude FFT (signal A + signal B)
- Magnitude FFT (signal A – signal B)
- Complex FFT (signal A + signal B)
- Complex FFT (signal A – signal B)
- Octave

- 1/3 Octave
- Cepstrum

Several of the result files can be showed in life-like animation modes, including:

- Hidden lines
- Coloured surfaces
- Colour map
- 3D wire frame
- Animated wallpaper of target surface
- Complete wallpaper with animated target area
- Wallpaper (CCD image) with grid overlay and/or colour map overlay
- ODS shapes, calculated at cursor position in frequency domain plots

Advanced Modal Analysis Software Option BZ 5318

BZ 5318 is fully integrated with Control and Analysis Software BZ 5310

The Advanced Modal Analysis software option includes:

- Modal parameters: Natural frequency, damping and mode shapes
- Single degree of freedom (SDOF), Multi degree of freedom (MDOF) and handfit curve fitters
- Modal assurance criterion (MAC), fit quality, complex mode indicator, function validation tools
- Forced response simulation in time and frequency domain
- Structural modification
- Animation of wire frame, including hidden lines, or animated colour maps

Ordering Information

Ometron Scanning Laser Doppler Vibrometer Type 8330 includes the following accessories:

SB 2507	Sensor Head, including two (X + Y) 16-bit, digitally controlled mirrors, full colour CCD camera, electromechanical PC-controlled laser shutter, drop-out detector and Doppler signal analyzer
UL 0179	Configured PC, including tower PC-cabinet (with monitor, keyboard and mouse) having the following items installed as default: 4-channel, 20 kHz/channel DSP (FFT) card, Framegrabber card, OpenGL graphics card, LAN card and Maul-Theet standard vibration analysis software. The configured PC comes as default with a set of 5 m cables between sensor head and PC

Accessories and Parts

SB 2507	Sensor Head for Type 8330 SLDV
UL 0179	Configured PC for Type 8330 SLDV
ZD 0859	2-channel, 80 kHz/ch. PCI based DSP (FFT) card for Type 8330 SLDV
ZD 0860	4-channel, 20 kHz/ch. PCI based DSP (FFT) card for Type 8330 SLDV, including two shaker generators with 20 kHz frequency bandwidth
ZE 0853	Framegrabber card for Type 8330 SLDV
ZE 0852	OpenGL graphics card
AO 0582	Short Cable Set for Type 8330 SLDV (5 m)

Multi-shaker Excitation and MIMO Analysis Software Option BZ 5319

BZ 5319 is fully integrated with Control and Analysis Software BZ 5310

The Multi-shaker excitation and MIMO software option includes:

- Simultaneous excitation with uncorrelated noise for a maximum of three shakers (2 generator outputs available on the 4-channel, 20 kHz/ch. DSP (FFT) card ZD 0860)
- Lock-in mode with on-line Nyquist diagram

Environmental

Operating temperature: from +5°C to +40°C (+40°F to +104°F)

Operating altitude: up to 2200 m (7200 ft) – this is a laser specification

Operating humidity: relative humidity up to 80% or more (non-condensing)

Power:

- Sensor head SB 2507: 85 – 264 V AC, 47 – 63 Hz, 72 VA, self-sensing
- Configured PC UL 0179: 100 – 120/220 – 240 V AC, 50/60 Hz, 1 kVA, selectable

Dimensions and weight:

- Sensor head SB 2507: 240 × 380 × 240 mm (9 × 15 × 9 inches), 15 kg (33 lbs.)
- Configured PC UL 0179: 209 × 483 × 452 mm (8 × 19 × 18 inches), 18 kg (40 lbs.)
- Cables and accessories: 5 kg (11 lbs.)

AO 0583	Medium length cable set for Type 8330 SLDV (10 m)
AO 0584	Long Cable Set for Type 8330 SLDV (20 m)
BZ 5310	Control and Analysis software for Type 8330 SLDV
BZ 5318	Advanced Modal Analysis software option
BZ 5319	Multi-shaker excitation and MIMO analysis software option
BZ 5313	MasterScan 8330-7 driver for I-DEAS version 7
BZ 5312	MasterScan 8330-8 driver for I-DEAS version 8
BZ 5311	MasterScan 8330-9 driver for I-DEAS version 9
UA 1577	Tripod, including CAM Head
UA 1579	250 kHz EG & G Correlator for Type 8330 SLDV
UA 1580	Driver Software for 250 kHz EG & G Correlator, including IEEEcard and cable
KE 1004	Transit case for Type 8330 SLDV Sensor Head
KE 1005	Transit case for Type 8330 SLDV PC

Upgrade kits of previous versions of Ometron VPI scanning vibrometers:

UA 1581	VPI upgrade kit no. 1
UA 1582	VPI upgrade kit no. 2
UA 1583	VPI upgrade kit no. 3
UA 1584	VPI upgrade kit no. 4
UA 1585	VPI upgrade kit no. 5
UA 1586	VPI upgrade kit no. 6

The relevant upgrade kit will depend on the serial number of the existing Ometron VPI scanning vibrometer model and whether a CCD camera is mounted

Scanning Laser Doppler Vibrometer Type 8330 has been developed by Ometron (UK) and can be purchased exclusively through the worldwide Brüel & Kjær sales and marketing organisation.