

Toshimitsu Asakura (Ed.)

# International Trends in Optics and Photonics

ICO IV



With 190 Figures



Springer

# Optical Methods for Reproducing Sounds from Old Phonograph Records

J. Uozumi and T. Asakura

**Summary.** During the long history of the development of sound recording technology, a large number of recordings have been made for academic purposes in various fields, as well as for amusement purposes. In utilizing those sound materials, however, there is a serious problem that early recording media such as wax cylinders and analog disks are less robust and have been, or can be, damaged easily by poor preservation conditions, careless handling and repeated reproductions. As a solution to such a problem, we have developed optical reproduction methods for old recording media: a laser-beam reflection method for wax cylinders, a laser diffraction method for old disc records, and an extension of the laser-beam reflection method for negative cylinders. Principles and properties of these methods are described.

## 1 Introduction

Since the advent of the first phonograph in 1877, the technology of recording and reproducing sounds has been developed extensively in response to strong public demand. During this history, various kinds of records appeared, from wax phonograph cylinders, a primitive and analog type of record, to optical disks based on modern digital technologies. At each stage of the development of records, a large number of recordings have been made for academic purposes in various fields such as musicology, linguistics and social sciences, as well as for amusement purposes, and they now provide us with a huge number of valuable sound materials.

However, there is a serious problem when we want to use those sound materials. Early recording media such as wax cylinders and analog disks are less robust and tend to be damaged more easily by poor preservation conditions, careless handling and repeated reproductions. Therefore, it is inadequate and sometimes almost impossible to reproduce sounds from records with severe damage by using traditional phonographs or record players. Moreover, even for disks in good condition, the use of a traditional phonograph gives rise to further wearing. Consequently not only is the quality of recorded sounds deteriorating but also the records themselves are being spoiled. This is a major problem since the records are sometimes regarded as a part of a valuable cultural inheritance.



Fig. 1. Pilsudski's wax cylinder (*right*) and its case (*left*)

To overcome such difficulties, we have developed optical reproduction methods for old recording media, for which traditional reproduction instruments are inadequate. In this chapter, we present the history and principles of such optical methods developed by our research group.

## 2 Wax Cylinder: Laser Beam Reflection Method

### 2.1 Prologue

As is well known, Thomas Edison, a very famous scientist and engineer in the United States, invented a recording machine which was called the "Phonograph." After 10 years' improvement, the phonograph, based on wax cylinders, became very popular. These wax cylinder phonographs were distributed all over the world for about 40 years from 1887 to 1932. In the United States, wax cylinder phonographs were used mainly for the purpose of amusement. In Europe, on the other hand, these phonographs were used for recording not only the voices of famous people but also well-known music and songs. In addition, the phonographs were used for the academic purpose of recording the various languages of (especially) minority races.

Using the phonograph over the years from 1902 to 1905, B. Pilsudski (1866–1918), a Polish anthropologist, recorded on wax cylinders the speech and songs of the Ainu people in Sakhalin and Hokkaido in order to study their culture. In 1977, Pilsudski's 65 wax cylinders were discovered in Poland and brought to the Research Institute for Electronic Science (RIES), Hokkaido University, in 1983 for the purpose of reproduction and investigation of the sounds recorded on them [1].

Somewhat later, using the phonograph over the years from 1920 to 1935, Takashi Kitazato (1870–1960), a language professor at Osaka University, recorded the speech and songs of many people in Japan, Taiwan, the Philippines, Malaya, Singapore and Indonesia to investigate the origin of the Japanese language. In 1985, Kitazato's 240 wax cylinders were discovered in Kyoto and also brought to the RIES for reproduction of their sounds.

## 2.2 Wax Cylinder

Phonograph cylinders of the Edison type used by Piłsudski were 55 mm in diameter and around 105 mm long (Fig. 1). On their surface, nearly 400 turns of grooves were cut with a pitch of 254  $\mu\text{m}$ . Since the rotational velocity of a phonograph in his time was some 140–160 rpm, the sound for 2–3 min was recorded on one wax cylinder. Since, in the recording for the wax cylinders, the grooves were cut only by the sound energy, the depth of the grooves was usually very shallow. For example, a groove of the wax cylinder recorded by a professional engineer during his time had a maximum depth of 50  $\mu\text{m}$ . In the case of a recording by an amateur, the maximum groove depth could be much shallower; for example, it was 10–30  $\mu\text{m}$  for Piłsudski's cylinders.

The stylus of the Edison-type phonograph puts a heavy pressure of approximately 20 g on the groove of the wax cylinder in the reproduction process and, therefore, there is a great risk of damaging the wax cylinder. Consequently, a reproduction system using a very light-pressure stylus was developed in our laboratory, and some cylinders in good condition were reproduced successfully by this system [2]. However, some cylinders remained unprocessed because they were cracked or in pieces. These broken wax cylinders were repaired as shown in Fig. 2. Even after the repair, however, the stylus method was inapplicable because the remaining gaps or missing parts could damage the stylus. To reproduce the sounds from the repaired cylinders, we developed a noncontact and nondestructive method based on the reflection property of a laser beam, and called the laser beam reflection method [1,3].

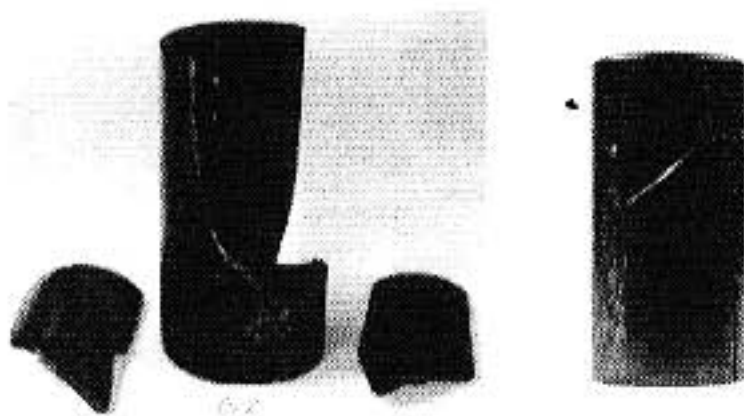

Fig. 2. Wax cylinder (*left*) in pieces and (*right*) after repair

## 2.3 Laser Beam Reflection Method

Figure 3 shows the principle of the laser beam method. The laser beam is incident onto the grooves cut on the surface of the wax cylinder and reflected at an angle obeying the reflection law. The reflected beam reaches the detecting plane, placed perpendicularly to the optical axis. The intersection point of the reflected beam is separated from the origin by a distance proportional

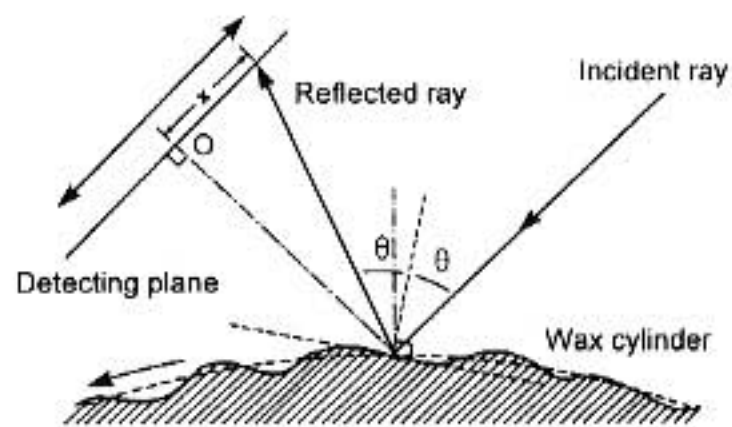

Fig. 3. Schematic 1-D diagram of the laser-beam reflection method

to the reflection angle. When the wax cylinder is rotated, the intersection point moves temporally on the detecting plane. This temporal variation of the intersection position is detected by a position-sensitive device (PSD) as a sound signal. The detected signal corresponds to the time-differentiated sound signal since the angle of the reflected ray depends on the inclination of the groove at the illuminated spot position. This differential property can be compensated in the frequency domain electronically, e.g. by using an audiographic equalizer.

A Gaussian beam emerging from the single-mode He-Ne laser with a wavelength of  $0.633 \mu\text{m}$  is focused by an objective lens with a waist diameter of  $30 \mu\text{m}$ . The wax cylinder, which is translated with rotation, is illuminated by a diverging Gaussian beam at a distance  $z$  from the beam waist. The illuminated spot diameter can be easily adjusted by moving the objective lens along the optical axis and, hence, by changing the distance  $z$ . This corresponds to changing the diameter of a stylus tip, in the stylus method, which cannot be changed easily due to its structure.

The driving part of the reproduction system is shown in Fig. 4 while the illuminating and detecting parts are partly shown in Fig. 5. The wax cylinder is set onto a rotary shaft 150 mm long, with a 50 mm maximum diameter on one side, and a 40 mm minimum diameter on the other. On the surface of the shaft, the screw thread is cut to prevent the wax cylinder from slipping off during the reproduction. The shaft is connected by a belt and reels to the AC motor. The rotating wax cylinder is placed on a movable stage traversed by the stepping motor in a direction perpendicular to the optical axis. This

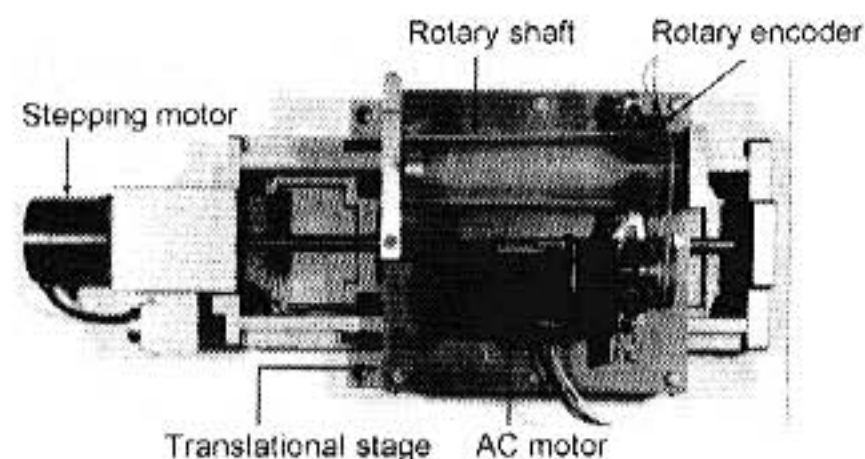
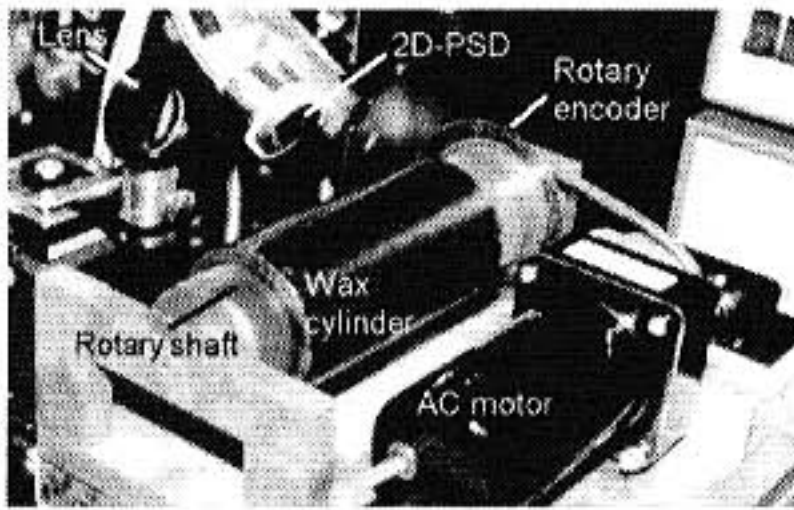

Fig. 4. Top view of the driving part of the reproduction system for wax cylinders



**Fig. 5.** Constructed reproduction system. A 2-D PSD is used for the detector, though a 1-D PSD was used in the first system. The lens driver for the tracking error compensation mentioned in Sect. 2.5 was removed in this configuration

stage can be moved with an accuracy of  $2\mu\text{m}$  per pulse, and it is set to be translated by one pitch of grooves with  $254\mu\text{m}$  for every rotation of the wax cylinder. The translation and rotation of the wax cylinder by means of the stepping motor and the AC motor are synchronized by using a rotary encoder.

#### 2.4 Properties and Problems of Reproduced Sounds

The laser beam method is based on geometrical optics. However, the actual reflection phenomenon from the grooves does not exactly obey the law of geometrical optics because of the finite diameter of the illuminating laser beam. We have found several problems in the development of this method:

1. Fidelity of the reproduced sound
2. Noise characteristics
3. Existence of echo
4. Occurrence of tracking error

We solved these problems by quantitative investigation of the reproduced sound signals.

To study the problems of fidelity and noise characteristics, we investigated the long-time frequency spectra of the sound signal produced by using the stylus method and the laser beam method. In the stylus method, we used the Edison-type phonograph; in the laser beam method, the illuminating spot diameter is  $80\mu\text{m}$ . As a result, we found that, in the case of the stylus method, the sound is in the frequency range from 250 Hz to 6 kHz. Especially, the resonant frequencies are at 400 Hz, 2 kHz and 4 kHz. In the laser beam method, the sound intensity with the low resonant frequency at 400 Hz is strong but the sound intensity with the high frequency is weak. The lack of high-frequency components makes the consonant indistinct.

The existence of noise inherent in the laser beam method was also examined. The low-frequency noise below 300 Hz is very strong and gives rise to a great deal of degradation on the articulation. On the other hand, the high-frequency noise above 1 kHz masks the reproduced sounds and becomes more obstructive to hearing the reproduced sounds.

To investigate the cause of the noise in the laser beam method, we studied the reflected spot at the detecting plane and found a random granular intensity pattern together with the reflected beam spot. This granular pattern may be produced from interference of the laser light reflected by the micro-structure distributed over the surface of the wax cylinder.

We also investigated the fidelity of the reproduced sound by changing the diameter of the illuminating laser beam. Figure 6 shows the variation of the long-time frequency spectra of the reproduced sounds with the spot diameters. With an increase in the beam diameter, the high-frequency components are greatly reduced. This may be due to the smoothing effect for the time-varying directions of the beams reflected from the groove within the illuminating beam spot. As mentioned above, the lack of high-frequency components makes the consonant indistinct. From this investigation, we conclude that the most suitable spot diameter is 30–130  $\mu\text{m}$  from the viewpoint of the fidelity of the reproduced sound.

Figure 6 also shows that the high-frequency noise suddenly decreases with an increase in the illuminating beam spot diameter. On the other hand, the low-frequency noise exists independently of any variation in the spot diameter. Therefore, the high-frequency noise can be effectively suppressed by using an illuminating beam with a large diameter. However, the noise signals in the low-frequency region have a constant intensity independent of the beam diameter. This low-frequency noise below 300 Hz may be suppressed by using a high-pass filter since the sound information in this region was not recorded originally. From the viewpoint of noise reduction, the noise is suppressed by using the laser beam with a spot diameter of over 80  $\mu\text{m}$ .

Another problem is an echo. The echo is overlapped on the reproduced sounds by an increase in the illuminating beam diameter. Figure 7 shows the autocorrelation functions of time-varying sound signals as a function of the distance  $z$ . The maximum peaks at  $\tau = 0$  s result from the sound signals reproduced from the grooves illuminated by the laser beam. The second peaks at  $\tau = 0.4$  s come from the echo and their magnitudes correspond to the intensity. It can be seen that the intensity of the echo increases with an increase in the beam diameter. The laser beam with a spot diameter larger

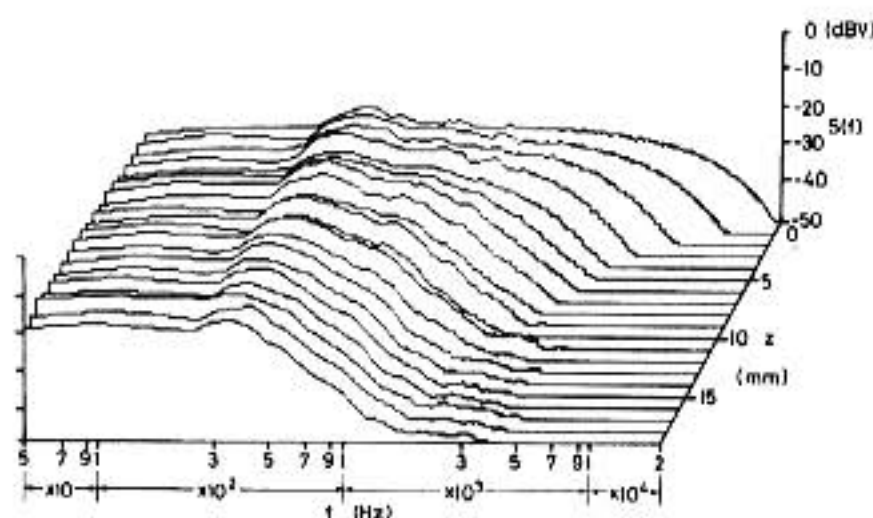

**Fig. 6.** Long-time frequency spectra obtained from sound signals reproduced by the laser beam reflection method as a function of the distance  $z$  from the beam waist

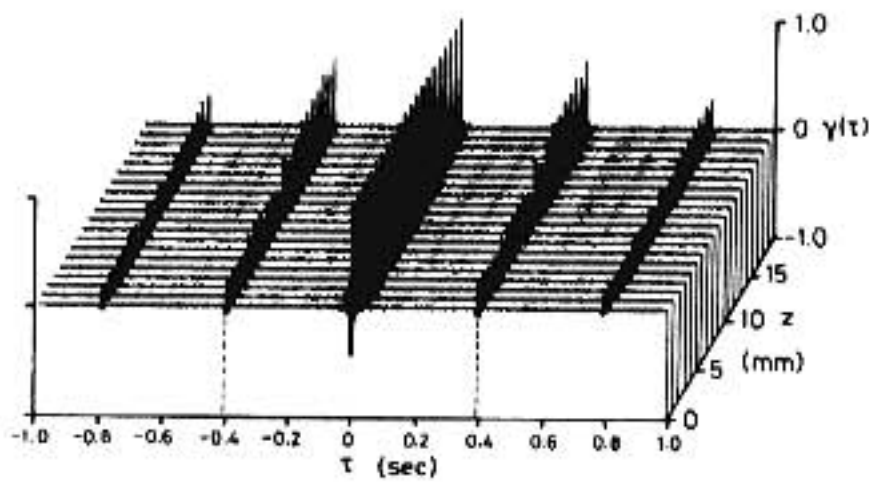

**Fig. 7.** Autocorrelation functions of reproduced sound signals as a function of the distance  $z$  from the beam waist

than the groove width illuminates the adjacent grooves and, therefore, causes the echo superposed on the main signal. We found that the intensity of the echo is to be under 30% of the main sound intensity for a spot diameter of less than  $100\ \mu\text{m}$ . Under this condition, the existence of the echo does not disturb hearing the reproduced sounds.

### 2.5 Tracking Error

There is a possibility that the illuminating beam leaves the grooves, producing a tracking error, because it does not directly trace the grooves of the wax cylinder as in the case of the stylus method. The tracking error results mainly from the position error of the driving part in the reproduction system. As shown in Fig. 8, if the tracking error occurs, the incident beam is reflected in the  $y$ -direction. In this case, the intensity of the reproduced sounds decreases suddenly because the intersection point of the reflected beam gets out of the one-dimensional (1-D) PSD.

To avoid the tracking error, we used the two-dimensional (2-D) PSD and the lens driver of a compact disc player. The 2-D PSD allows independent detection of the  $x$ - and  $y$ -coordinates of the beam spot position. Using the electrical conversion system shown in Fig. 9, the time-varying values of the  $x$ - and  $y$ -coordinates of the reflected beam become the sound and the tracking error signals, respectively. The tracking error signal is fed to the lens driver

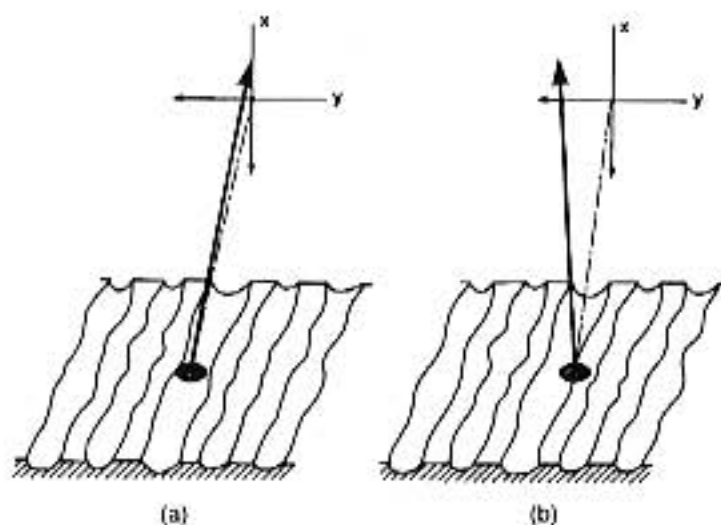

**Fig. 8.** Optical rays reflected from the grooves (a) without and (b) with tracking error

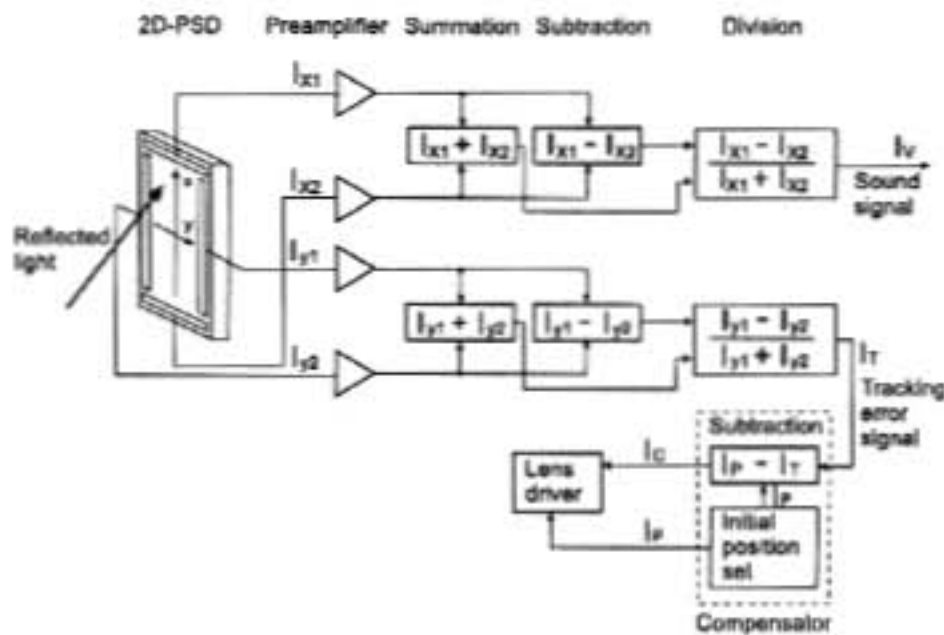

**Fig. 9.** Schematic diagram of the electrical conversion system of the position signals detected by the 2-D PSD into sound and tracking error signal currents

to move the lens. By moving the lens, the illuminating spot moves to the center of the groove to keep the illumination normal.

## 2.6 Further Development of the Method

The laser beam reflection method introduced above has been developed further to improve its performance and to be applied to old records of various types.

In the latest system developed in our laboratory, a laser diode (LD) with a wavelength of  $0.78 \mu\text{m}$  and a maximum power of 20 mW is used as the light source to make the optical system compact as shown in Fig. 10. In addition, an imaging lens and a pinhole are inserted between the wax cylinder and the 2-D PSD. In this configuration, the lens produces an image of the cylinder surface on the pinhole plane. The pinhole transmits only the image of the illuminating spot and rejects the stray light coming from surrounding parts of the cylinder surface, thus reducing the noise due to the ambient light, e.g. from a fluorescent lamp. A photograph of the latest system is shown in Fig. 11. This compact system was used in 1996 to reproduce the sound from a wax cylinder on which a piano tune, "Hungarian Dance" played by Johannes Brahms, was recorded on 1889. In this new system, the tracking is realized

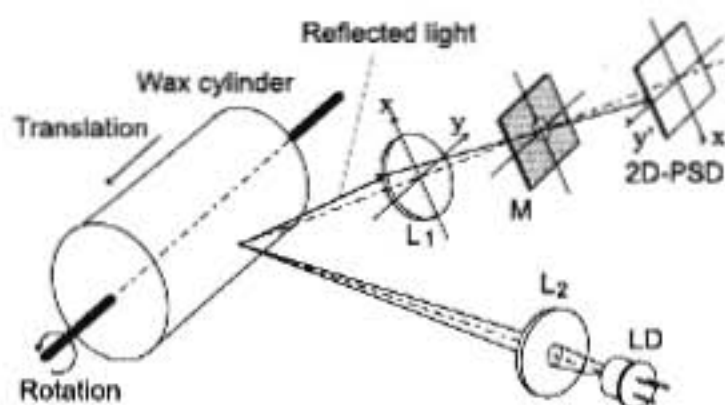

**Fig. 10.** Schematic diagram of the recent reproduction system for wax cylinders. The pinhole is placed in the image plane of the lens and transmits only the image of the illuminating spot and rejects the ambient stray light

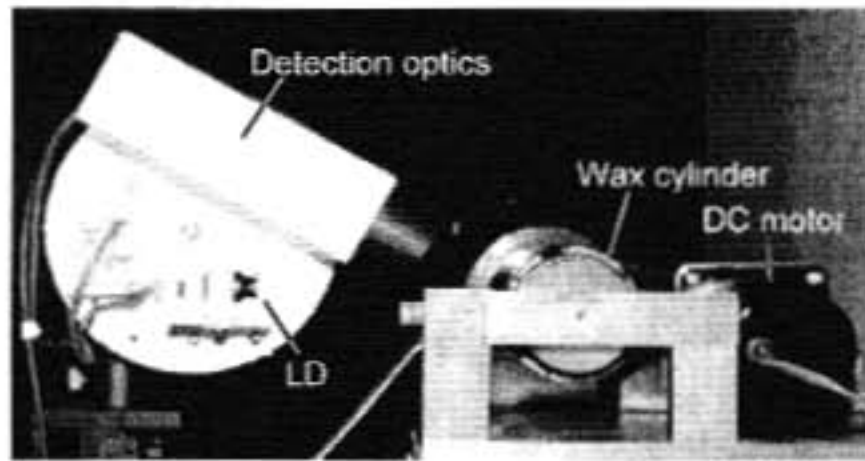

**Fig. 11.** Photograph of the recent reproduction system for wax cylinders. Detection optics includes the imaging lens, pinhole and 2-D PSD as shown in Fig. 10. A lens is mounted on the front end of the holder of the LD

by adjusting the translation speed of the stage on which the wax cylinder is mounted, rather than using the lens drive.

Some interesting attempts to improve the method have been made by Nakamura et al. [4,5]. As an alternative way of improving the tracking, a contact method based on a lightweight optical fiber was proposed. To solve the noise problem, an incoherent light source was utilized, by which the granular pattern in the beam spot at the detection plane is suppressed.

## 2.7 Replication of Cylinders

There is a quite different way of reproducing sounds from a wax cylinder without any risk of damaging the cylinder by the heavy stylus of a traditional phonograph, i.e. making a replica of the cylinder and playing it directly on a phonograph. The replication also has the advantage of preserving the current conditions of the cylinder without further deterioration. For the purpose of preserving the Pilsudski cylinders, replicas of them were made using the epoxy resin and molding technique developed in the dental field [2].

First, the wax cylinder was mounted on the axis of an outer cylindrical mold with a 10 cm i.d. Then, dental impression material (Exaflex injection type F, GC LTD) was poured into the space between the cylinder and the wall of the mold, as shown in Fig. 12 (left). The impression material, which was made of vinyl-silicone rubber, has many advantages, such as high accuracy, fluidity and flexibility. After the silicon rubber hardened, the wax cylinder

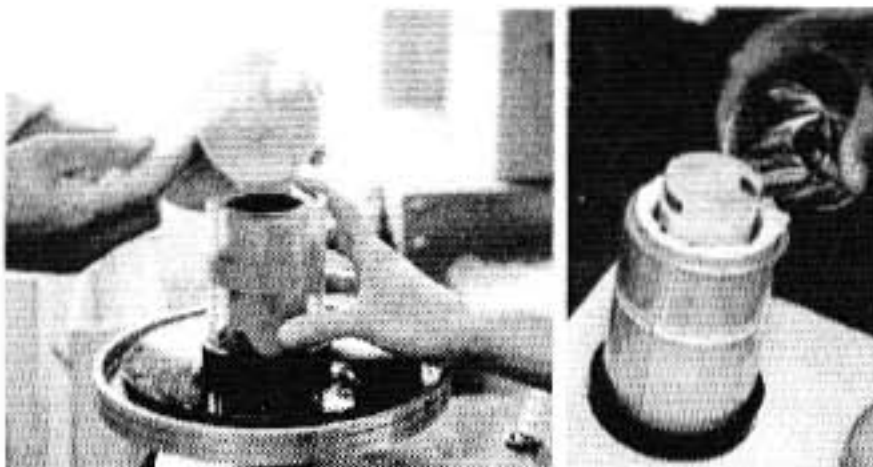

**Fig. 12.** Replication procedures for the wax cylinder: (left) the dental impression material is poured into the space between the cylinder and the wall of the mold; and (right) the epoxy resin is poured into the silicone rubber mold

was carefully removed. Next, the epoxy resin (Spurr Resin, TAAB LTD), which was thoroughly mixed and degassed in a vacuum chamber, was poured into the silicon rubber mold, as shown in Fig. 12 (right). The resin was completely cured in a constant temperature oven for 36 hours. It was shown to be possible to reproduce usable sounds from the replicas using a working model of the original Edison-type machine.

### 3 Disk: Laser Diffraction Method

#### 3.1 Disk

After the project of sound reproduction from the Pilsudski wax cylinders, many old disk records were found in Japan on which old speech and songs of native Formosan tribes had been recorded. Some of these disks are made of ebonite, some of aluminum, and the others of aluminum alloy. All the disk records were monaural, being recorded with a rotational frequency of 78 rpm. The width of the sound grooves and the separation between two adjacent grooves were 50 and 200  $\mu\text{m}$ , respectively, though they vary depending on the type of records and the recorded sound intensity. Since their contents are important from linguistic and folkloric viewpoints, reproduction of the sound from these disks is strongly desirable. Apparently due to improper storage of these disks, however, almost all are covered with mold, and most of the aluminum and aluminum alloy disks are rusted, some lightly and some seriously, and have many scratches. These undesirable changes to the disk surfaces prevent ordinary reproduction of the sound using conventional means such as phonographs and record players. In particular, the rust on the aluminum and aluminum alloy disks, whether slight or serious, disturbs the tracking of the sound grooves by the stylus and makes reproduction of the sound almost impossible.

Therefore, a noncontact optical reproduction method was again considered. However, since the recording principles of disks and wax cylinders are different, the laser beam reflection method developed for the cylinders is inapplicable to the disk. That is, the sound signals of disk records are encoded as a horizontal variation of the sound grooves as shown in Fig. 13. Therefore,

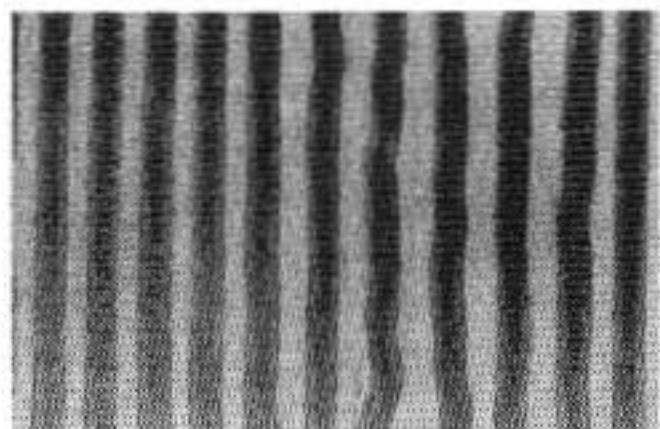
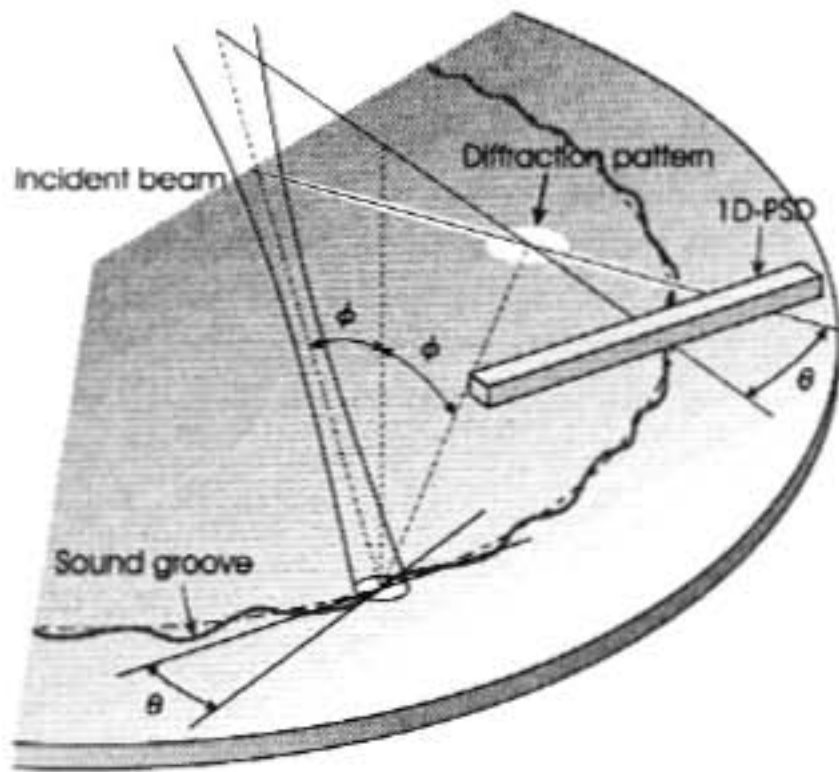

**Fig. 13.** Sound grooves of a disk. Grooves wind laterally corresponding to the sound signals encoded. The pitch of grooves is not constant and varies according to the recording level.

we have developed another reproduction method that exploits the diffraction phenomenon of the laser light by the sound grooves [6].

### 3.2 Laser Diffraction Method

The principle of detection of sound from the records is illustrated in Fig. 14. In the case of disks of this type, sound signals are encoded as lateral variations of the groove around its mean curve that corresponds to a groove involving no sound signal. A cross section of the sound grooves is approximately V-shaped, though its details depend on the cutting stylus used for the recording. Consider a Gaussian beam from a laser illuminating a sound groove with an illumination angle  $\phi$  so that the plane of illumination includes the axis of the disk. Then, the laser light on reflection suffer from phase modulations proportional to the depth variations across the illuminated area and produces a specific diffraction pattern that consists of a central specular spot and two linear wings extending toward opposite directions from the central spot as shown in Fig. 15. The angle  $\theta$  of the linear wings from the illumination plane is equal to the angle between the tangents of the mean curve and the groove at the illuminated spot. Therefore, by setting a 1-D PSD perpendicular to the plane of illumination at a moderate distance from the specular spot, the variation of  $\theta$  is detected as a coordinate at which the linear wing intersects



**Fig. 14.** Principle of sound reproduction from a disk. The mean curve of a groove is nearly a circle (*broken curve*) concentric with the disk. If the illuminating spot is large enough to cover the groove but not too large to illuminate adjacent grooves, the direction  $\theta$  of the groove at the illuminated spot is converted to the direction of the linear part of the diffraction pattern. In the actual system, a normal illumination ( $\phi = 0$ ) was employed



Fig. 15. Diffraction pattern from the sound groove of a disk. The central specular spot and one of two linear wings are shown

the 1-D PSD. Here, it is noted that the PSD detects  $\tan \theta$ , which is the first derivative of the sound signal. In the system actually constructed, we used a 2-D PSD instead of the 1-D PSD in order to have the sufficient light intensity and to reduce the speckle noise as shown in Fig. 17.

### 3.3 Tracking

In the case of disks, it is much more difficult to track the sound groove with the laser spot than in the case of wax cylinders. This difficulty comes from the property that, due to sound signals, the sound groove winds, in the same plane in which the tracking direction lies. Therefore, we needed to develop a different principle for tracking the disks.

The tracking principle we employed is as follows. If the illuminated spot is just on the center of the groove as shown in Fig. 16b, the two linear wings of the diffraction pattern have almost the same intensity. When the groove deviates slightly toward one side from the center of the illuminated spot, however, the intensity in the wing on that side increases compared with the wing on the opposite side (Figs. 16a and c). This is because the intensity in the right wing arises mainly from the left slope of the groove and the deviation of the groove to the right makes the illumination of the left slope stronger than that of the right slope, and vice versa.

This change in intensity balance between the two wings can be used for compensating tracking errors. Two photodiodes are placed on both sides of the central spot as shown in Fig. 16d, and detect the intensities of both wings. The difference of the outputs from the two PDs is approximately proportional to the amount of deviation of the groove, and is employed to drive the disk

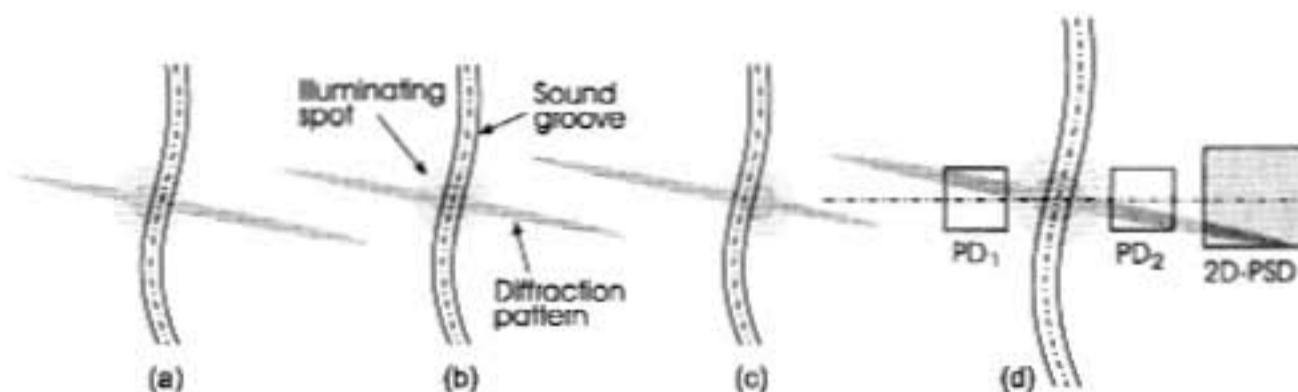
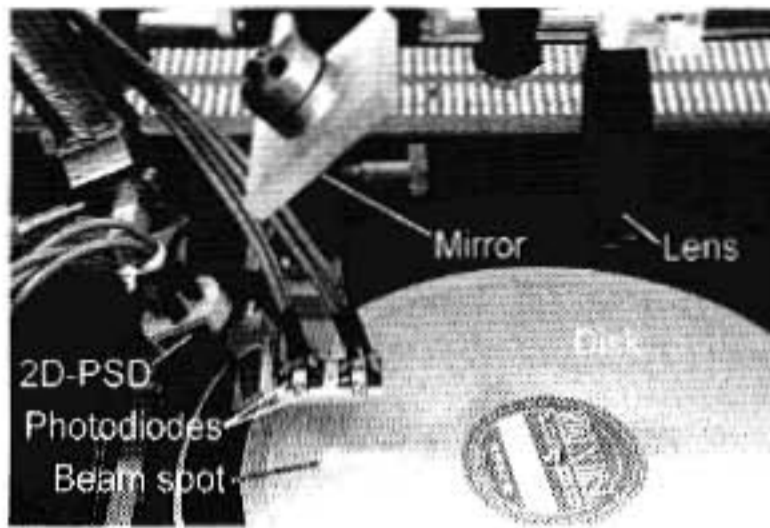

Fig. 16. Principle of detecting tracking errors. As the groove (a) deviates to the right, (b) meets the spot center, and (c) deviates to the left, the intensity balance in the two wings of the diffraction pattern changes as shown. (d) The intensity balance is detected by two photodiodes PD<sub>1</sub> and PD<sub>2</sub>



**Fig. 17.** Illumination optics of the reproduction system for disks. The laser beam coming from the right passes through the lens, is turned downward by the mirror, passes through the hole between the two photodiodes and illuminates the disk

laterally to compensate for the deviation of the groove from the illuminated spot. In an actual system, the differential electric signal was processed with a low-pass filter to give an appropriate response rate and to reduce the effect of noise before being fed into the driving circuit of the translation stage on which a turntable is mounted with the disk.

### 3.4 Reproduction System

On the basis of the principle given above, an actual system was constructed as shown in Fig. 17. The system consists of three parts: the optical system, sound detection system, and driving and tracking system.

In the optical system, a Gaussian beam from an He-Ne laser at  $0.633\ \mu\text{m}$  impinges on a disk record at a distance  $z$  from its beam waist after passing through a lens system forming a suitable beam-waist width. The illuminated spot size at the disk surface can be adjusted by changing the distance  $z$ , which is controlled by varying the position of the last lens of the lens system. The illuminating beam is set normal to the disk surface by a mirror ( $\phi = 0$  in Fig. 14). In the sound detecting system, an output signal from the 2-D PSD is fed into the reconstruction circuit and converted into an electric signal to produce a sound signal. This converting process and the electronic circuit are the same as those used in the laser beam reflection method. In the driving and tracking system, outputs from the two photodiodes are fed into the driving circuit of the translation stage through a differential amplifier, while the disk is rotated at a constant rate of 78 rpm by a turntable mounted on the translation stage.

## 4 Negative Cylinder: Modification of the Laser Beam Reflection Method

### 4.1 Negative Cylinder

Recently, we discovered that many phonograph cylinders are preserved in Germany in the form of metallic negative cylinders on which the folk music of

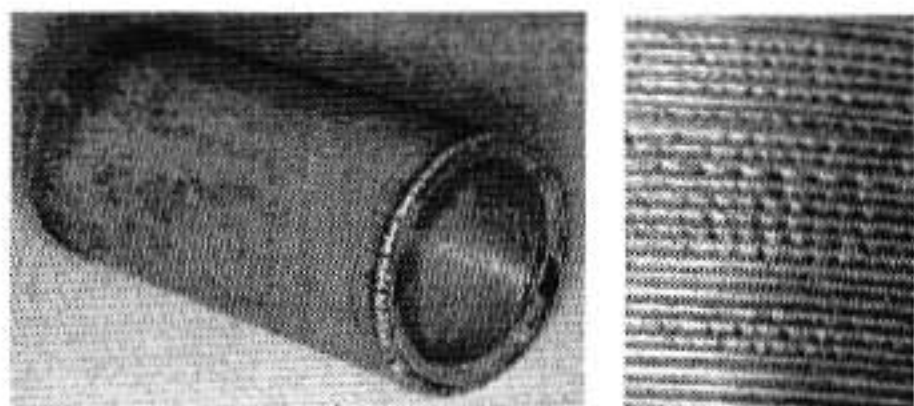

Fig. 18. (Left) Negative cylinder. (Right) Inside surface of the negative cylinder showing the height variation of the sound bank which is a replica of the sound groove of the original wax cylinder

various countries in the world are recorded. The negative cylinder was made by plating a wax cylinder with copper and then by melting down the original wax cylinder. In this process, the sound is transferred into convex portions on the inside surface. Consequently, any stylus method is ineffective and these negatives have been left for a long time without any investigation of the valuable sounds recorded on them. It was expected, however, that the laser beam reflection method developed for wax cylinders could also be effective for the negatives. To apply the method to the negatives, some modifications were made and a new system was constructed [4,7].

The negative cylinders we employed for the development of the instrument seem to be produced from typical wax cylinders and have nearly the same dimensions of 56, 54 and 110 mm in the outer and inner diameters and length, respectively (Fig. 18 (left)). The typical rotation rates were 144 and 160 rpm, and a sound lasting 2–3 min and the sound signal were encoded on the inside surface, not as a groove but as a spiral *bank* with a pitch of 1/100 inch (Fig. 18 (right)).

#### 4.2 Principle and Reproduction System

The principle of sound reproduction from negative cylinders is basically the same as that from wax cylinders. With reference to Fig. 19, a laser beam is incident on the center of the sound bank and the sound signal recorded as height variations of the sound bank are converted into a position  $x$  of the

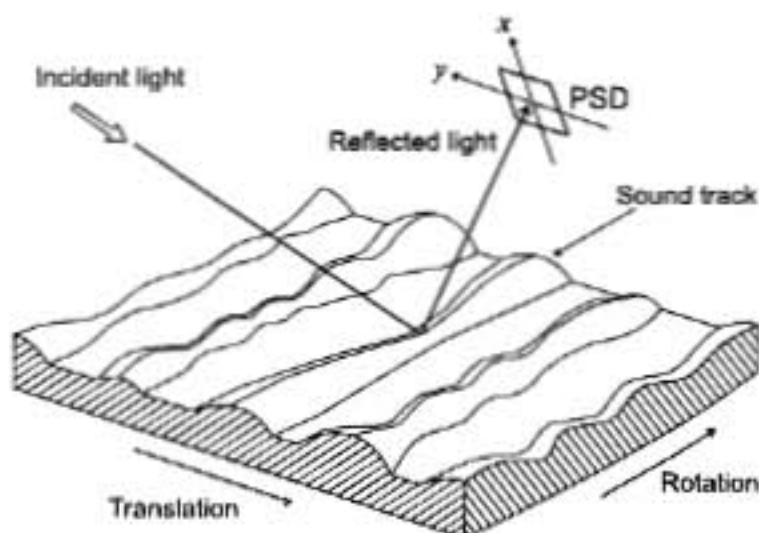
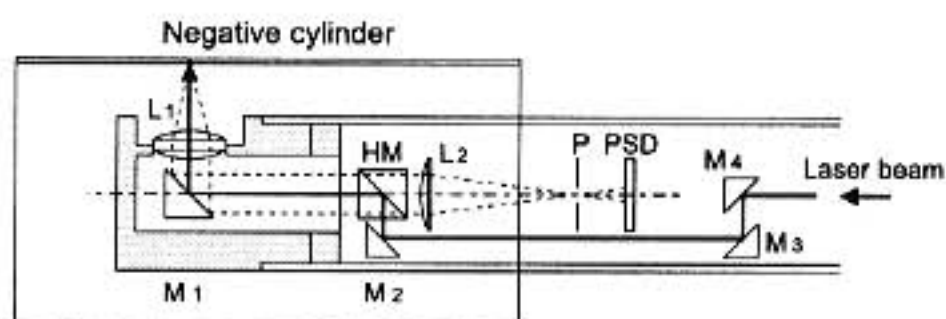
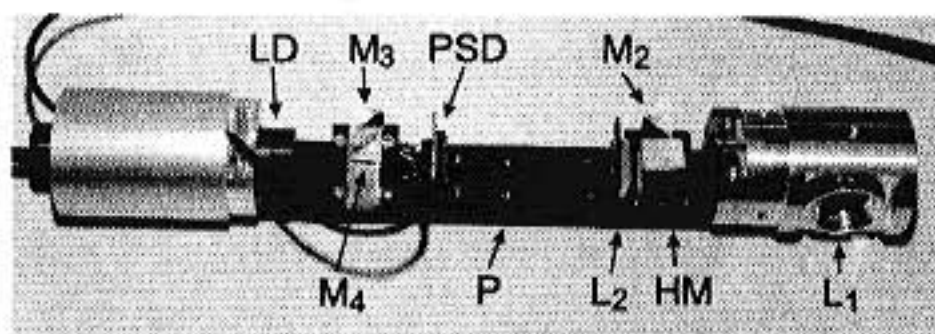

Fig. 19. Principle of the laser beam reflection method. As the cylinder rotates, the reflection direction varies in the  $x$ -direction due to the height variation of the sound bank (sound track). The deviation of the illuminated spot from the center of the sound bank gives the variation in the  $y$ -direction



**Fig. 20.** Schematic diagram of the optical head. The lens  $L_1$ , mirrors  $M_1$  and  $M_2$ , and beam splitter  $HM$  are common to the illumination and detection optics



**Fig. 21.** Photograph of the optical head with the cover removed for display. The mirror  $M_1$  is not shown in this photograph.  $P$  indicates the position of the pinhole which is unmounted in this image

reflected beam impinging on the PSD. On the other hand, if the illuminated spot deviates from the center of the bank, the reflected beam varies in the  $y$ -direction, which produces a signal for the tracking error and can be used to compensate for the deviation of the illuminated spot by adjusting the translation speed of the cylinder. These two signals in the  $x$ - and  $y$ -directions can be detected independently by setting a 2-D PSD.

In the case of the negative cylinder, a compact optical system that can be inserted into the cylinder is required. A schematic diagram and a photograph of a reconstructed optical head are shown in Figs. 20 and 21, respectively. A laser beam from an LD with a wavelength of 670 nm is guided by mirrors  $M_4$ ,  $M_3$ ,  $M_2$  and  $M_1$ , and a beam splitter  $HM$ , to a lens  $L_1$ , which focuses the beam onto the inside surface of the cylinder. The beam reflected from the cylinder surface goes back through the same part of the system up to  $HM$ , and then is led by the lens  $L_2$  to the PSD. A pinhole  $P$  is placed in the focal plane of  $L_2$ , and its role is the same as in the system shown in Fig. 10.

A schematic diagram of the developed system is shown in Fig. 22. The system consists of the drive and control units, the optical head being mounted on the former. The signal converter processes the output of the PSD and yields the sound and tracking error signals,  $V_x$  and  $V_y$ .  $V_y$  is sent to the pulse motor driver via the low-pass filter and the V-F converter. The rotation rate is adjustable in the range of 140–160 rpm. A photograph of the drive unit is shown in Fig. 23.

Using this system, we successfully reproduced the sounds from some negatives, including performances of Japanese musical instruments, *shamisen* and *koto*, which were recorded in Berlin in 1901. The reproduced sounds have a much better quality than existing wax cylinders. This is partly because wax cylinders currently available have been played many times and are considerably worn out while the negatives preserve the initial quality of their original

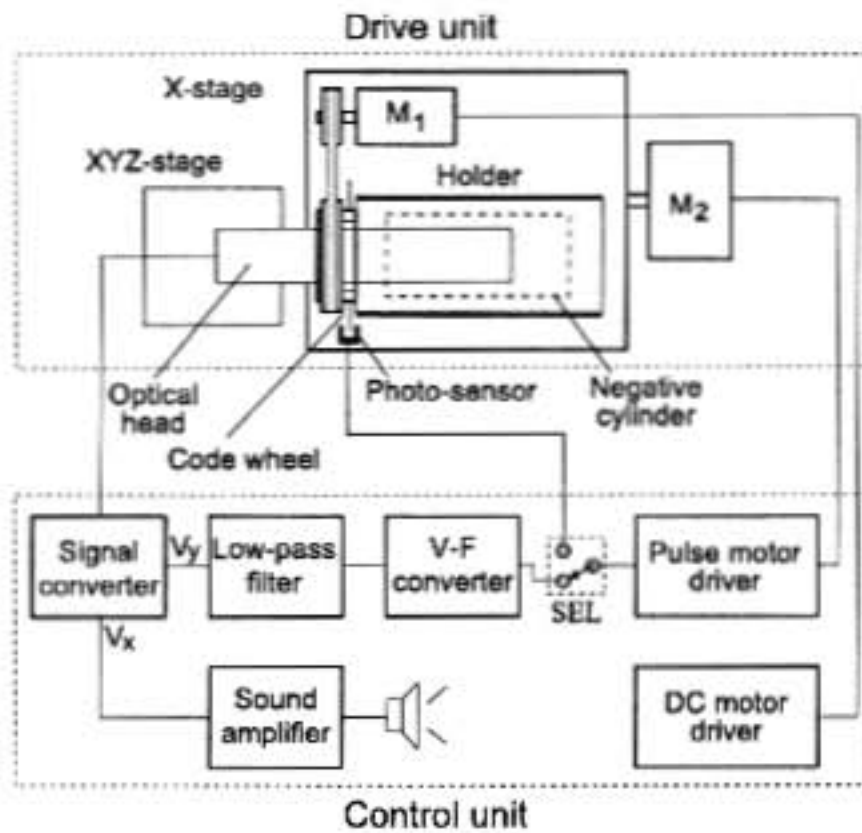

**Fig. 22.** Diagram of the optical player for negatives. The DC motor  $M_1$  rotates the holder while the pulse motor  $M_2$  drives the  $x$ -stage. The output of the PSD is processed to yield the sound and tracking error signals,  $V_x$  and  $V_y$ .  $V_x$  is amplified and drives the speaker, while  $V_y$  is sent to the pulse motor driver via the low-pass filter and the V-F converter (auto-tracking mode). The pulse motor can also be controlled by the signal from the photosensor (constant translation mode)

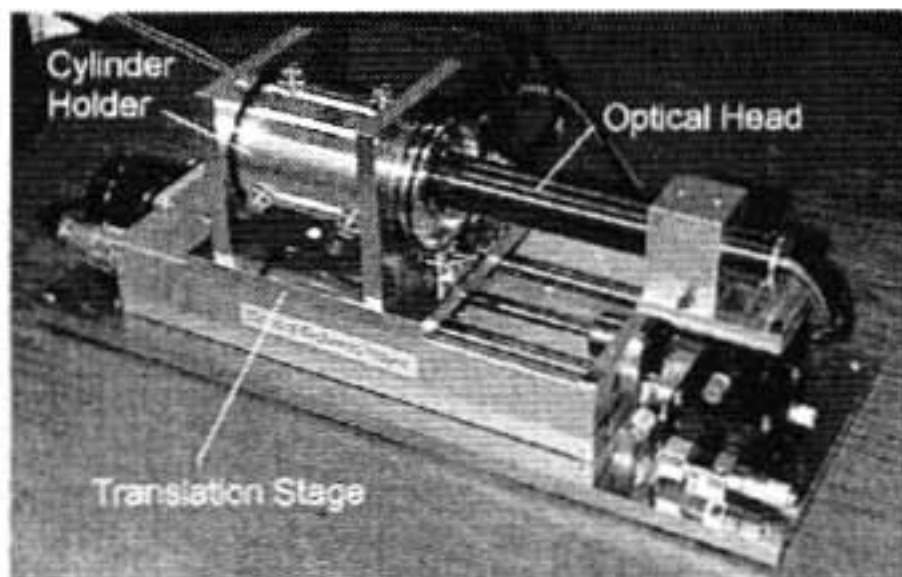

**Fig. 23.** Drive unit of the optical negative player. The optical head is inserted into the negative held inside the cylinder holder which is mounted on the translation stage ( $x$ -stage)

wax cylinders. The present instrument is expected to be used to reveal valuable sound information that has been left undetected for a long time.

## 5 Conclusion

Several optical methods have been developed for reproducing sounds from old recording media of various types. The quality of the reproduced sounds varies depending on the type of record. For wax cylinders, the quality is

satisfactory unless the original sound quality itself is poor, while it is very good for negative cylinders. On the other hand, disks do not always give satisfactory sound quality due to the difficulty of tracking and need further improvement. A further reduction of noise is another problem in all the cases. In spite of some remaining problems, these noncontact and nondestructive methods are powerful tools for playing damaged records, for which traditional phonographs are inadequate. They may well be used to reproduce valuable historical sounds.

## References

1. Iwai, T., Asakura, T., Ifukube, T., Kawashima, T. (1986) Reproduction of sound from old wax phonograph cylinders using the laser-beam reflection method. *Appl. Opt.* **25**, 597-604
2. Ifukube, T., Kawashima, T., Asakura, T. (1989) New methods of sound reproduction from old wax phonograph cylinders. *J. Acoust. Soc. Am.* **85**, 1759-1766
3. Asakura, T., Uozumi, J., Iwai, T., Nakamura, T. (1999) Study on reproduction of sound from old wax phonograph cylinders using the laser. *Proc. OWLS V* (Springer, Berlin) (to be published)
4. Nakamura, T., Ushizaka, T., Uozumi, J., Asakura, T. (1997) Optical reproduction of sounds from old phonographic wax cylinders. *Proc. SPIE* **3190**, 304-313
5. Nakamura, T., Asakura, T. (1999) Reproduction of sounds from an old Russian phonographic wax cylinder by various optical methods. *Proc. OWLS V* (Springer, Berlin) (to be published)
6. Uozumi, J., Asakura, T. (1988) Reproduction of sound from old disks by the laser diffraction method. *Appl. Opt.* **27**, 2671-2676
7. Uozumi, J., Ushizaka, T., Asakura, T. (1999) Optical reproduction of sounds from negative phonograph cylinders. *Proc. OWLS V* (Springer, Berlin) (to be published)