



MIT IAP 2011 Laptop Based Radar: Block Diagram, Schematics, Bill of Material, and Fabrication Instructions*

Presented at the 2011 MIT Independent Activities Period (IAP)

Gregory L. Charvat, PhD
MIT Lincoln Laboratory

10-28 January 2011

*This work is sponsored by the Department of the Air Force under Air Force Contract #FA8721-05-C-0002. Opinions, interpretations, conclusions and recommendations are those of the authors and are not necessarily endorsed by the United States Government.

MIT Lincoln Laboratory

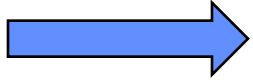

- **Motivation**
- **Fully Assembled Radar Kit**
- **Block Diagram**
- **Schematics**
- **Bill of Material (BOM)**
- **Step-by-Step Fabrication Instructions**
- **How to use the radar**



- **Increase MIT Campus and MIT Lincoln Laboratory collaboration**
- **Increase pool of staff candidates with relevant skills for MIT Lincoln Laboratory**
- **Introduce students to the field of applied electromagnetics, RF design, signal processing, analog design, and radar system design.**
 - **By making something interesting students could become motivated in the long term to work through challenging ECE and physics courses.**



- **Motivation**

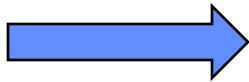

- **Fully Assembled Radar Kit**
- **Block Diagram**
- **Schematics**
- **Bill of Material (BOM)**
- **Step-by-Step Fabrication Instructions**
- **How to use the radar**

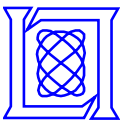

Fully Assembled Radar Kit

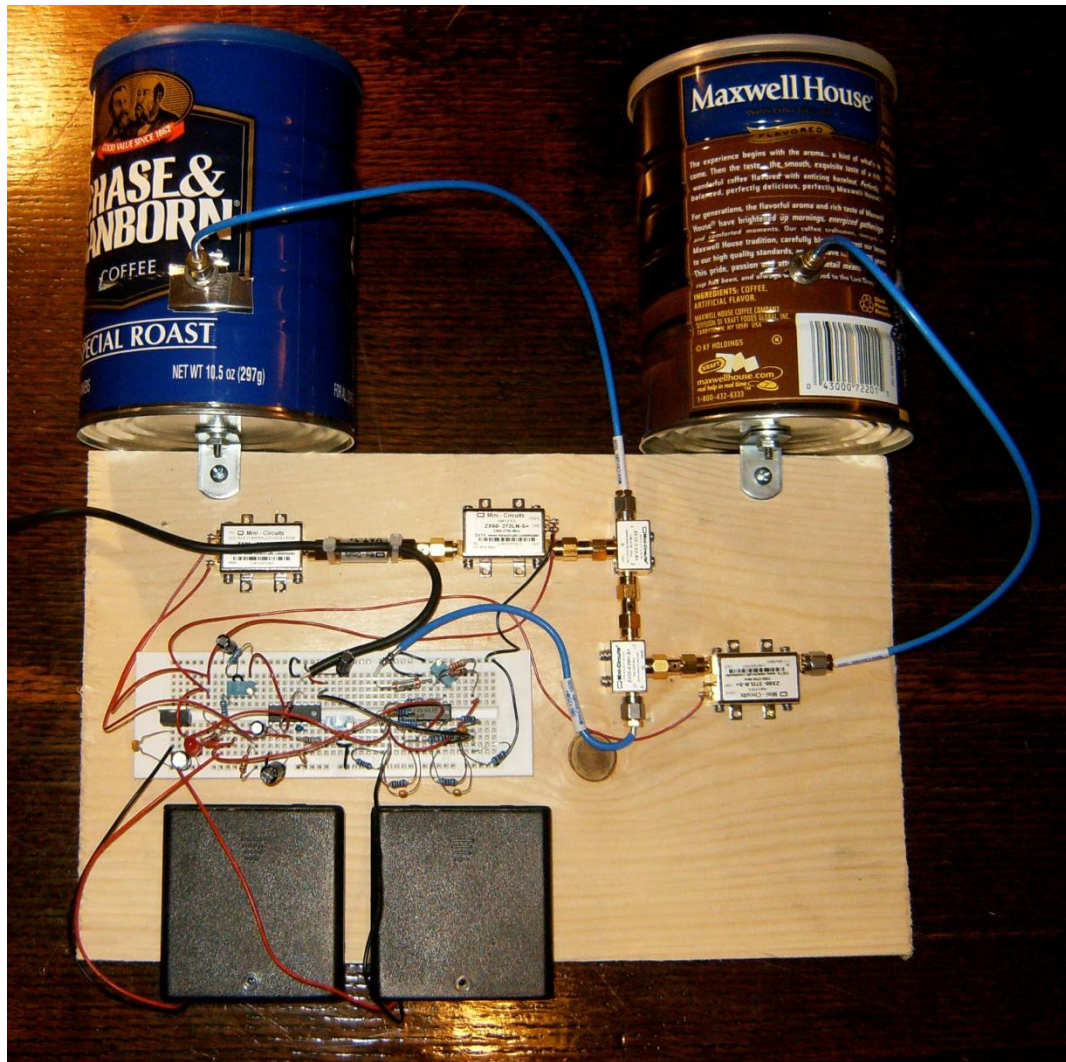

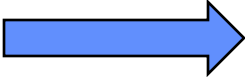

- **Motivation**
- **Fully Assembled Radar Kit**
-  • **Block Diagram**
- **Schematics**
- **Bill of Material (BOM)**
- **Step-by-Step Fabrication Instructions**
- **How to use the radar**



Block Diagram

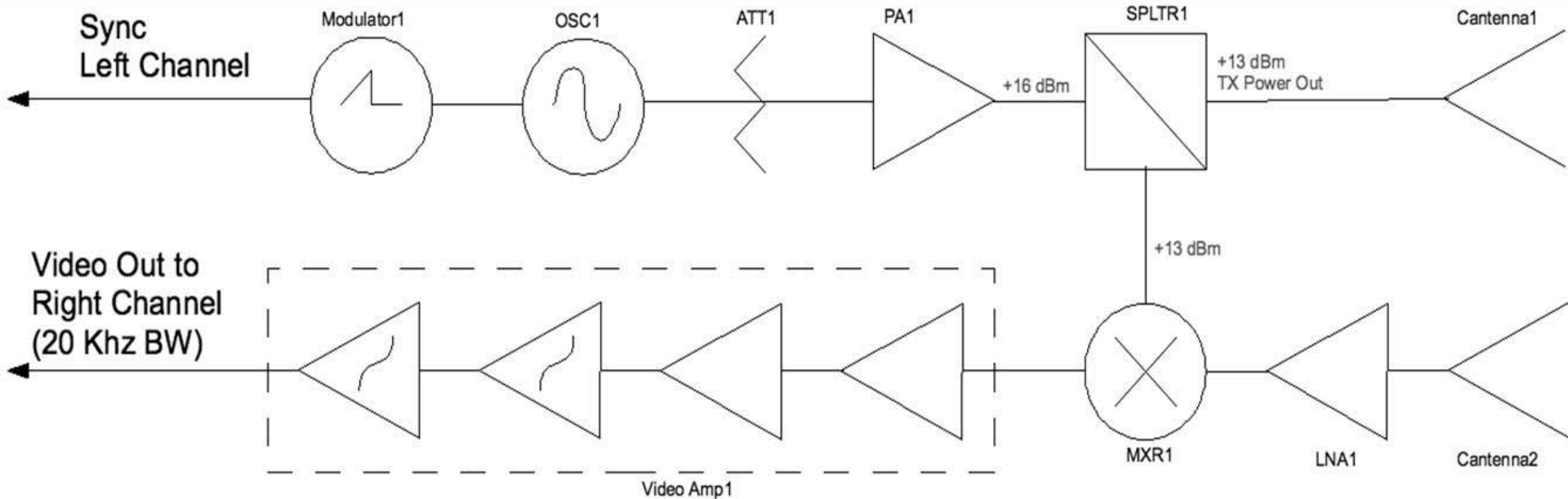

- **FMCW**
- **Operates in ISM band of 2.4 GHz**
- **approximately 10 mW TX power**
- **Max range approximately 1 km for 10 dBsm**
- **Data acquisition/signal processing in MATLAB**
 - **sound card digitizes sync pulse and de-chirp**
 - Supporting FFT, 2-pulse canceller, SAR image**

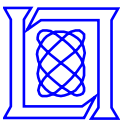

Callouts

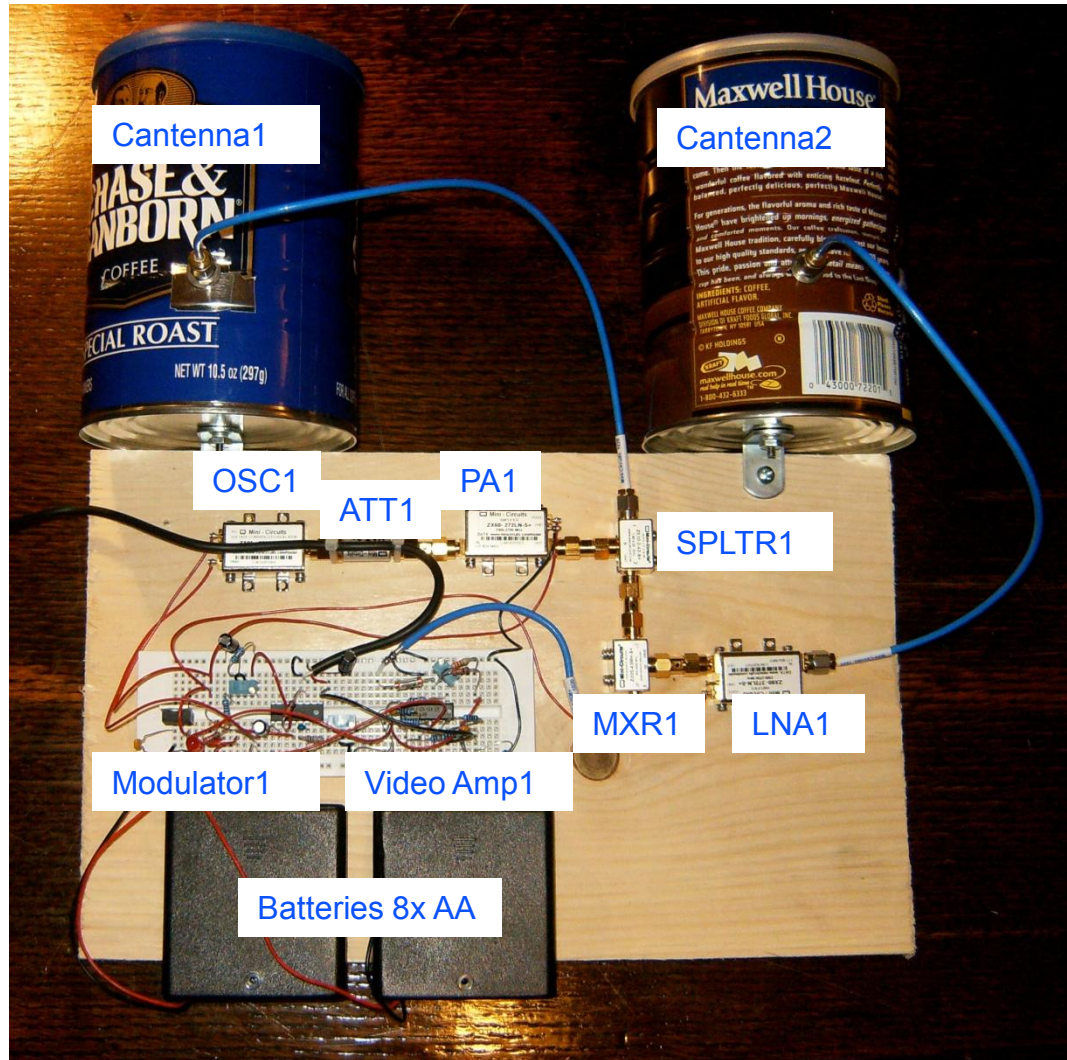



- **Motivation**
- **Fully Assembled Radar Kit**
- **Block Diagram**
- **Schematics**
- **Bill of Material (BOM)**
- **Step-by-Step Fabrication Instructions**
- **How to use the radar**



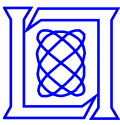

Video Amp1

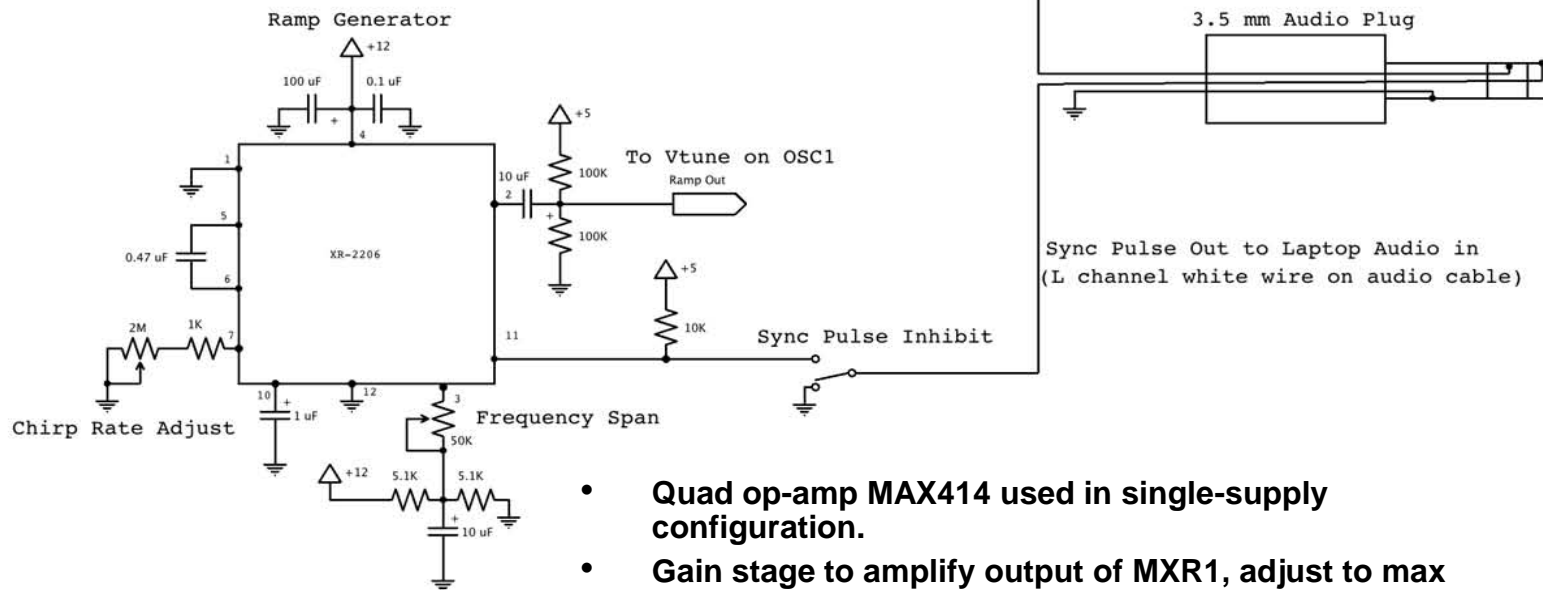
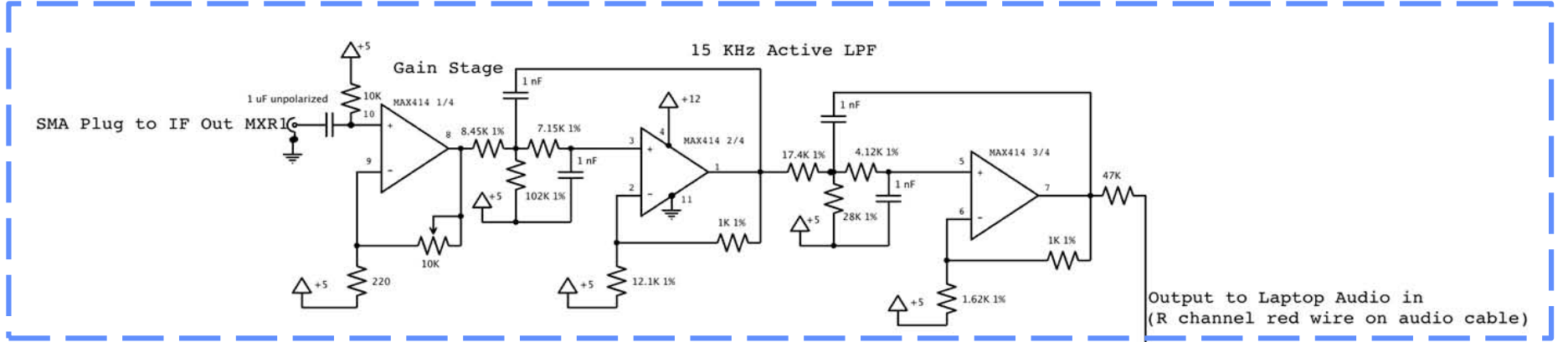

Output to Laptop Audio in
(R channel red wire on audio cable)

Sync Pulse Out to Laptop Audio in
(L channel white wire on audio cable)

- Quad op-amp MAX414 used in single-supply configuration.
- Gain stage to amplify output of MXR1, adjust to max before op-amp clips during FMCW mode
- Followed by 15 KHz 4th order LPF
 - prevents aliasing of PC's input audio port

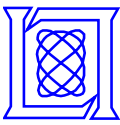

Modulator1

- Produces linear ramp which modulates OSC1 Vtune input pin
 - Vtune voltage is proportional to transmit frequency
 - Linear Ramping of Vtune causes OSC1 to produce a linear FM chirp used for transmit and receive
 - Set up-ramp time to 20ms, for 40ms triangle wave period
 - Set magnitude of ramp to desired transmit bandwidth
- Produces receive trigger signal synchronized with start of linear ramp

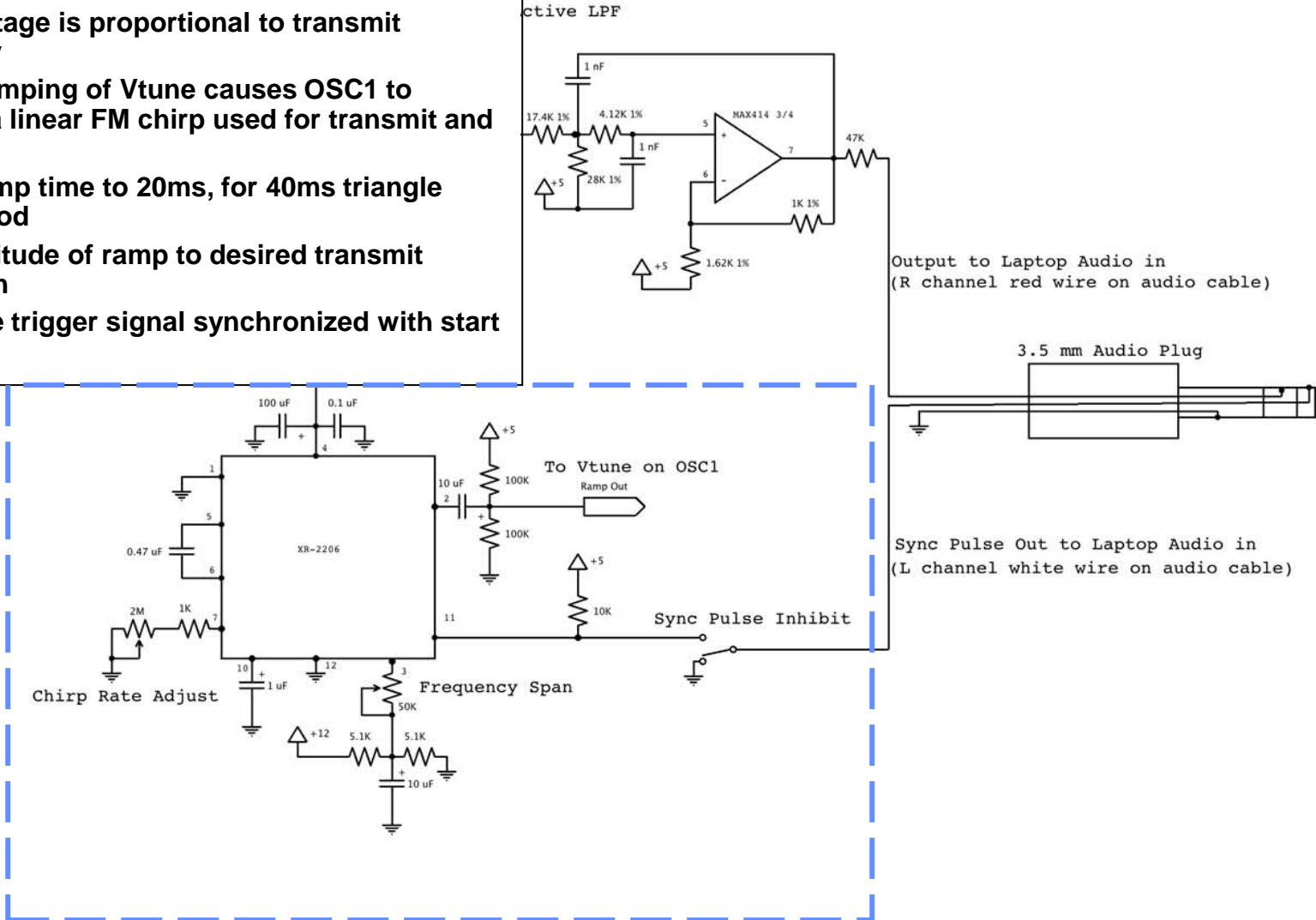



Power Supply & Battery Pack

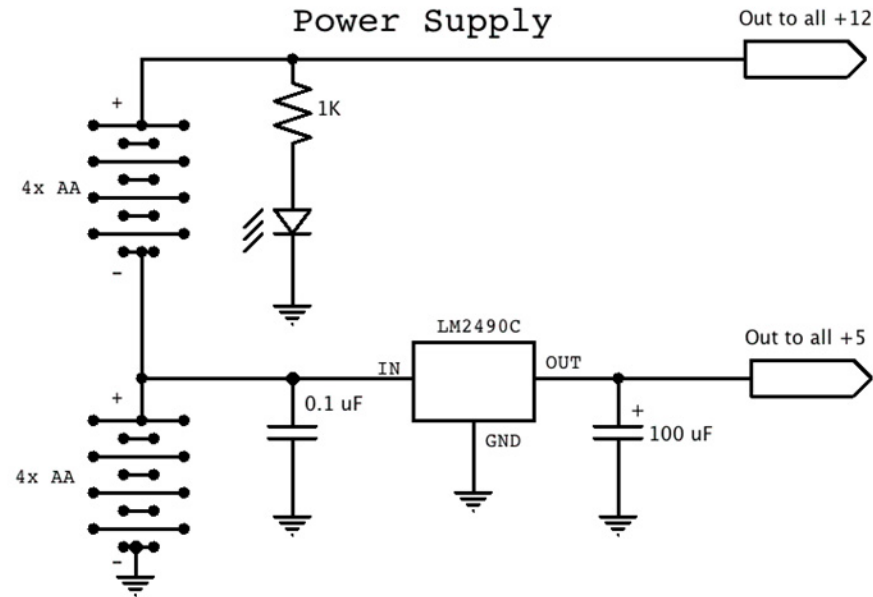

- 2 battery packs, 4x AA's in each producing 6V and 12V
- 5 VDC low-dropout regulator is fed by 6V from battery packs
 - powers RF components and provides reference voltage for analog circuits which enables single supply operation
- 12 VDC powers analog circuits including Modulator1 and Video Amp1



- **Motivation**
- **Fully Assembled Radar Kit**
- **Block Diagram**
- **Schematics**
- **Bill of Material (BOM)**
- **Step-by-Step Fabrication Instructions**
- **How to use the radar**



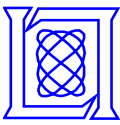

Bill of Materials (BOM) 1/3

Radar RF							
Callout	Qty/Kit	Part#	Description	Supplier	Supplier Part #	Cost Each	Subtotal
OSC1	1	ZX95-2536C+	2315-2536 MC VCO, +6 dBm Out	Mini-Circuits	ZX95-2536C+	\$42.50	\$42.50
ATT1	1	VAT-3+	3dB SMA M-F attenuator	Mini-Circuits	VAT-3+	\$9.95	\$9.95
PA1/LNA1	2	ZX60-272LN-S+	Gain 14 dB, NF=1.2 dB, IP1= 18.5 dBm	Mini-Circuits	ZX60-272LN-S+	\$39.95	\$79.90
SPLTR1	1	ZX10-2-42+	1900-4200 Mc, 0.1 dB insertion loss	Mini-Circuits	ZX10-2-42+	\$34.95	\$34.95
MXR1	1	ZX05-43MH-S+	13 dBm LO, RF to LO loss 6.1 dB, IP1 9dBm	Mini-Circuits	ZX05-43MH-S+	\$46.45	\$46.45
SMA M-M Barrels	4	SM-SM50+	SMA-SMA M-M barrel	Mini-Circuits	SM-SM50+	\$5.45	\$21.80
Cantennas							
Can	2	TBD	TBD	local grocery store	TBD	\$5.00	\$10.00
L bracket	2	NA	L-bracket, 7/8", zinc plated	McMaster Carr	1556A24	\$0.35	\$0.70
SMA F bulkhead	2	901-9889-RFX	SMA bulkhead F solder cup	Mouser	523-901-9889-RFX	\$4.27	\$8.54
6-32 screws	1	NA	6-32 machine screw, 5/8" length, pk of 100	McMaster Carr	90279A150	\$3.49	\$3.49
6-32 nuts	1	NA	6-32 hex nuts, pk of 100	McMaster Carr	90480A007	\$1.09	\$1.09
6-32 lockwashers	1	NA	lock washers for 6- 32 screws, pk of 100	McMaster Carr	91102A730	\$0.71	\$0.71
6" SMA M-M Cables	3	086-12SM+	SMA-SMA M-M 6" cable	Mini-Circuits	086-12SM+	\$9.65	\$28.95



Bill of Materials (BOM) 2/3

		Analog, Power, and misc				
Wood Screws	1 NA	brass #2 wood screws 3/8" long, pk 100	McMaster Carr	98685A225	\$3.70	\$3.70
measuring tape	1 NA	50' long measuring tape	McMaster Carr	6839A68	\$11.22	\$11.22
Wood	1 NA	12" wide by 1" thick 8' long wood	Home Depot	458538	\$14.37	\$14.37
Modulator1	1 XR-2206	Function Generator Chip	Mouser	701-XR2206CP-F	\$4.05	\$4.05
Video Amp1	1 MAX414CPD+	low-noise quad op-amp	Digi-Key	MAX414CPD+-ND	\$14.46	\$14.46
solderless breadboard	1 EXP-300E	6.5x1.75" solderless breadboard	Mouser	510-EXP-300E	\$7.00	\$7.00
C1-4	4 SA105A102JAR	1000 pf 5% capacitor	Digi-Key	478-3147-1-ND	\$0.22	\$0.86
R1a_1	1 MFR-25FBB-8K45	8450 ohm 1% resistor	Digi-Key	8.45KXBK-ND	\$0.11	\$0.11
R1b_1	1 MFR-25FBB-102K	102K ohm 1% resistor	Digi-Key	102KXBK-ND	\$0.11	\$0.11
R2_1	1 MFR-25FBB-7K15	7150 ohm 1% resistor	Digi-Key	7.15KXBK-ND	\$0.11	\$0.11
Rf_1_2	3 MFR-25FBB-1K00	1K ohm 1% resistor	Digi-Key	1.00KXBK-ND	\$0.11	\$0.34
Rg_1	1 MFR-25FBB-12K1	12.1K ohm 1% resistor	Digi-Key	12.1KXBK-ND	\$0.11	\$0.11
R1a_2	1 MFR-25FBB-17K4	17.4K ohm 1% resistor	Digi-Key	17.4KXBK-ND	\$0.11	\$0.11
R1b_2	1 MFR-25FBB-28K0	28K ohm 1% resistor	Digi-Key	28.0KXBK-ND	\$0.11	\$0.11
R2_2	1 MFR-25FBB-4K12	4120 ohm 1% resistor	Digi-Key	4.12KXBK-ND	\$0.11	\$0.11
Rg_2	1 MFR-25FBB-1K62	1620 ohm 1% resistor	Digi-Key	1.62KXBK-ND	\$0.11	\$0.11
decoupling cap	2 K104Z15Y5VE5TH5	0.1 uf	Mouser	594-K104Z15Y5VE5TH5	\$0.05	\$0.10

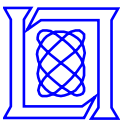

Bill of Materials (BOM) 3/3

decoupling cap	2 UVR1E101MED1TD	100 uf	Mouser	647-UVR1E101MED1TD	\$0.03	\$0.06
trimmer potentiometer	1 PV36Y103C01B00	10k	Mouser	81-PV36Y103C01B00	\$0.92	\$0.92
gain resistor	1 CFP1/4CT52R201J	200 ohm, 5%	Mouser	660-CFP1/4CT52R201J	\$0.05	\$0.05
Battery pack	2 SBH-341-1AS-R	4xAA battery pack with power switch	Jameco	216187	\$0.95	\$1.90
AA batteries	8 PC1500	AA battery	Mouser	613-PC1500	\$0.54	\$4.32
5V regulator	1 LM2940CT-5.0/NOPB	5V low dropout regulator	Digi-Key	LM2940CT-5.0-ND	\$1.77	\$1.77
Audio cord	1 172-2236	3.5 mm plug to stripped wires	Mouser	172-2236	\$2.42	\$2.42
Wire ties	2 41931	4" cable ties	Mouser	517-41931	\$0.04	\$0.08
tuning capacitor	1 FK28Y5V1E474Z	0.47 uf capacitor	Mouser	810-FK28Y5V1E474Z	\$0.21	\$0.21
2M trimmer potentiometer	1 PV36W205C01B00	2M trimmer potentiometer	Mouser	81-PV36W205C01B00	\$0.92	\$0.92
50K trimmer potentiometer	1 PV36W503C01B00	50K trimmer potentiometer	Mouser	81-PV36W503C01B00	\$0.92	\$0.92
1uF cap	1 UVR1H010MDD1TD	1 uF electrolytic cap	Mouser	647-UVR1H010MDD1TD	\$0.04	\$0.04
10 uF cap	1 UVR1H100MDD1TA	10 uF electrolytic cap	Mouser	647-UVR1H100MDD1TA	\$0.03	\$0.03
5.1K resistor	2 MF1/4DCT52R5101F	5.1K resistor	Mouser	660-MF1/4DCT52R5101F	\$0.05	\$0.10
10K resistor	2 CCF0710K0JKE36	10K resistor	Mouser	71-CCF0710K0JKE36	\$0.04	\$0.08
LED	1 TLHR5400	Red LED	Mouser	78-TLHR5400	\$0.07	\$0.07
1K LED resistor	1 CCF071K00JKE36	1K resistor	Mouser	71-CCF071K00JKE36	\$0.04	\$0.04
100K resistor	2 CCF07100KJKR36	100K resistor	Mouser	71-CCF07-J-100K	\$0.04	\$0.08
47K Resistor	12 CCF0747K0JKR36	47K 5% resistor	Mouser	71-CCF07-J-47K	\$0.04	\$0.48
1 uF capacitor unpolarized	T356A105M020AT73 1 01	1 uf tantalum capacitor	Mouser	80-T356A105M20AT-TR	\$0.31	\$0.31
Total						\$359.96



Outline

- **Motivation**
- **Fully Assembled Radar Kit**
- **Block Diagram**
- **Schematics**
- **Bill of Material (BOM)**
- **Step-by-Step Fabrication Instructions**
- **How to use the radar**

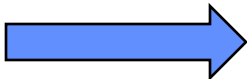



Fabrication



- **Unpack radar kit**
- **Sort parts according to function**
 - microwave parts
 - resistors
 - semiconductors
 - electrolytic capacitors
 - capacitors
 - hardware
 - etc



Fabrication

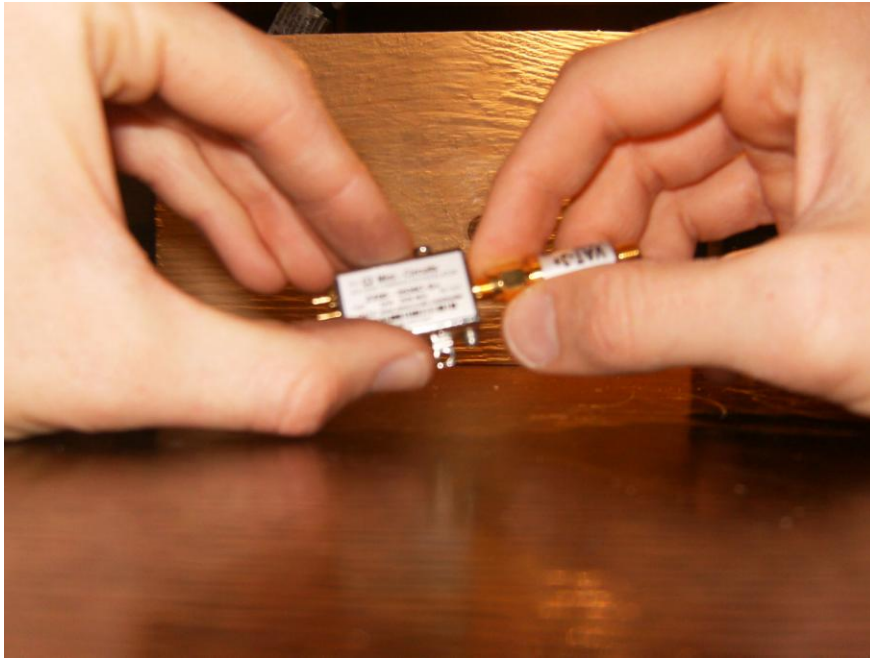

- Thread the 3 dB attenuator ATT1 onto the VCO OSC1
- Thread a SMA-SMA barrel onto ATT1



Fabrication



- **Thread the barrel from ATT1 on to the input to PA1**
- **Locate the 2nd amplifier module, LNA1**
 - **thread a SMA-SMA barrel on to the output of LNA1**



Fabrication

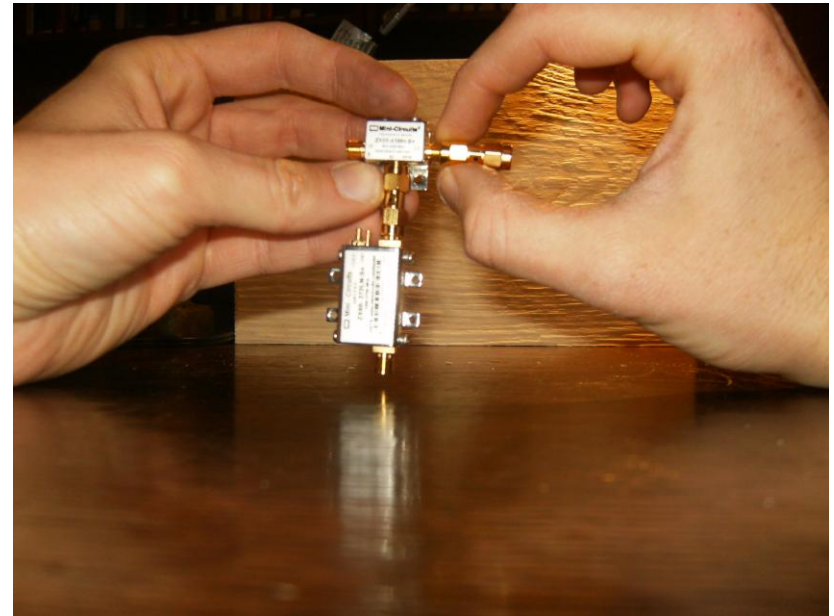
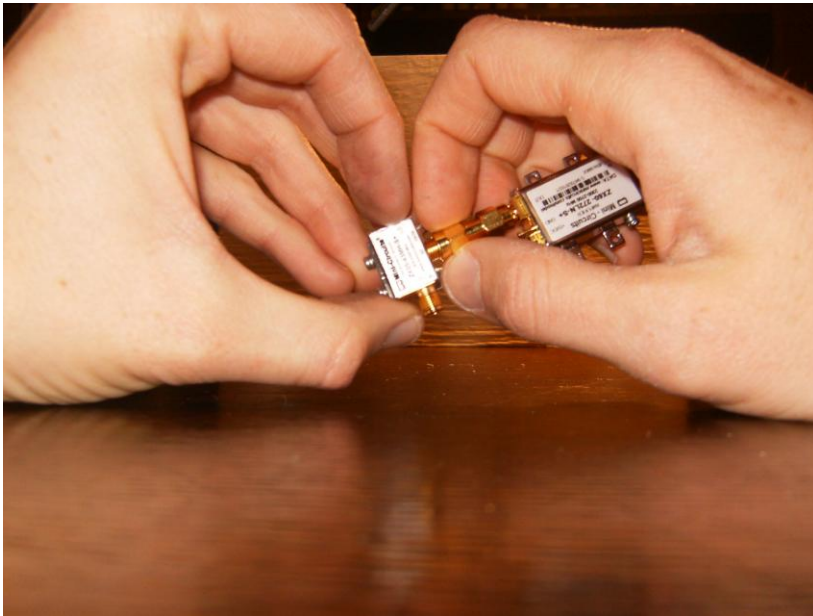

- Thread the SMA barrel from the output of LNA1 to the RF port of MXR1
- Thread a SMA-SMA barrel onto the LO port of MXR1



Fabrication

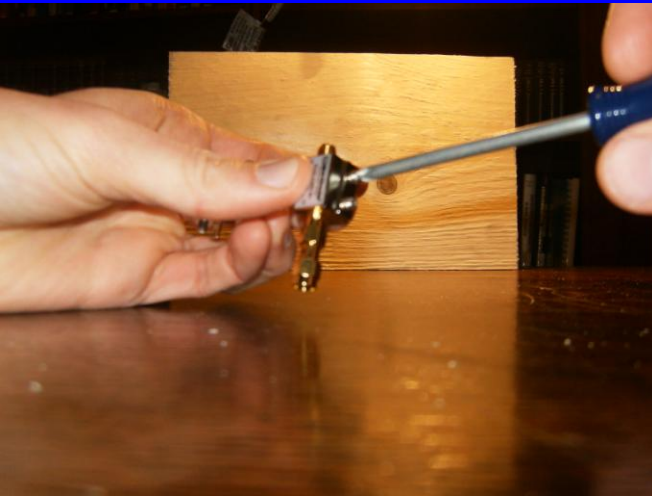

- **Remove the mounting bracket on MXR1**
 - remove the two Phillips screws
 - remove the mounting bracket
 - thread the Phillips screws back into MXR1



Fabrication

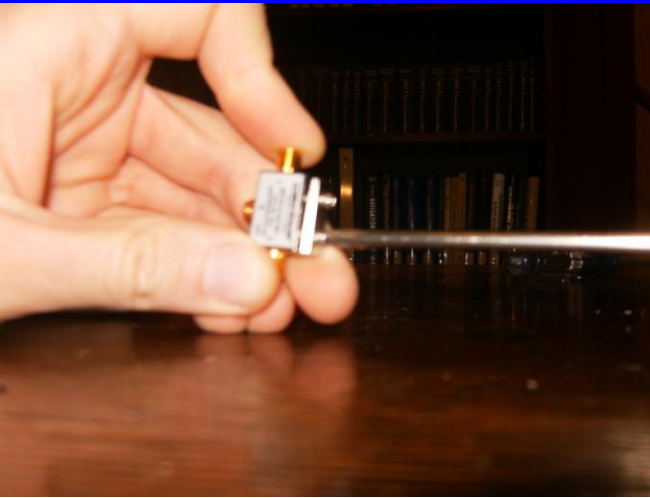

- **Find the power splitter SPLTR1**
- **Similar to MXR1, remove the mounting bracket**
 - remove the two Phillips screws
 - remove the mounting bracket
 - thread the Phillips screws back into SPLTR1

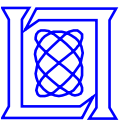

Fabrication

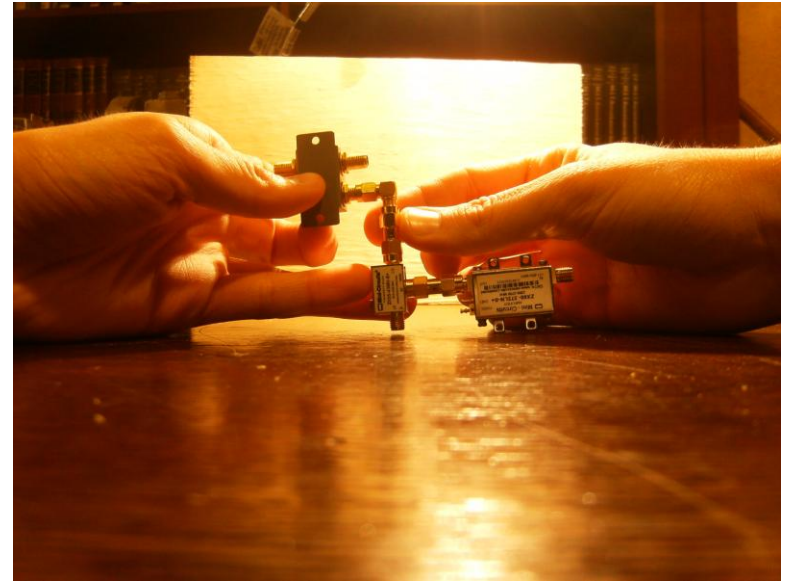

- Thread a SMA-SMA barrel on to the output of PA1
- Thread the SMA-SMA barrel from the LO port of MXR1 to one of the outputs of SPLTR1 (note: SPLTR1 shown in the above image is different in appearance than the one in the kit)



Fabrication

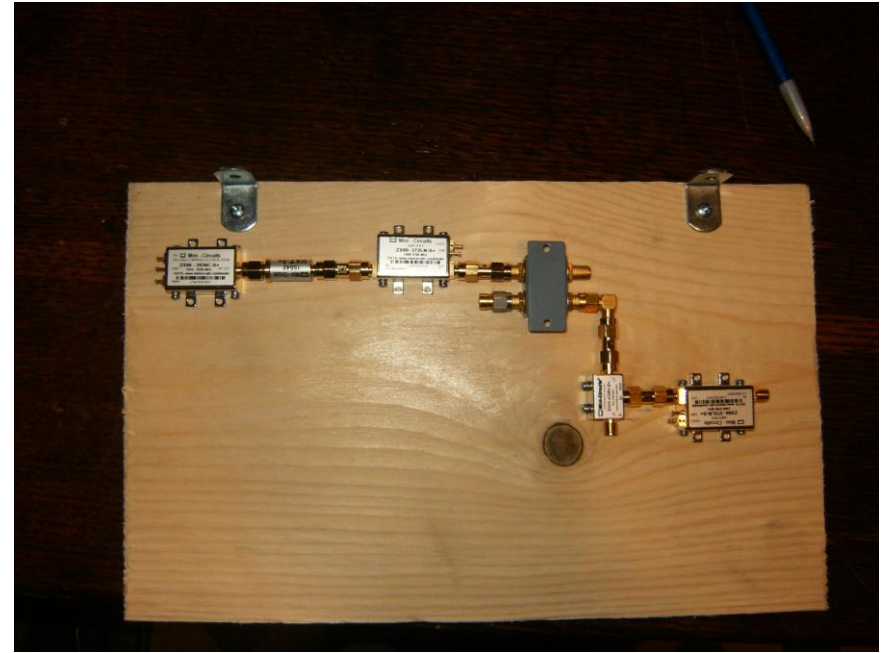
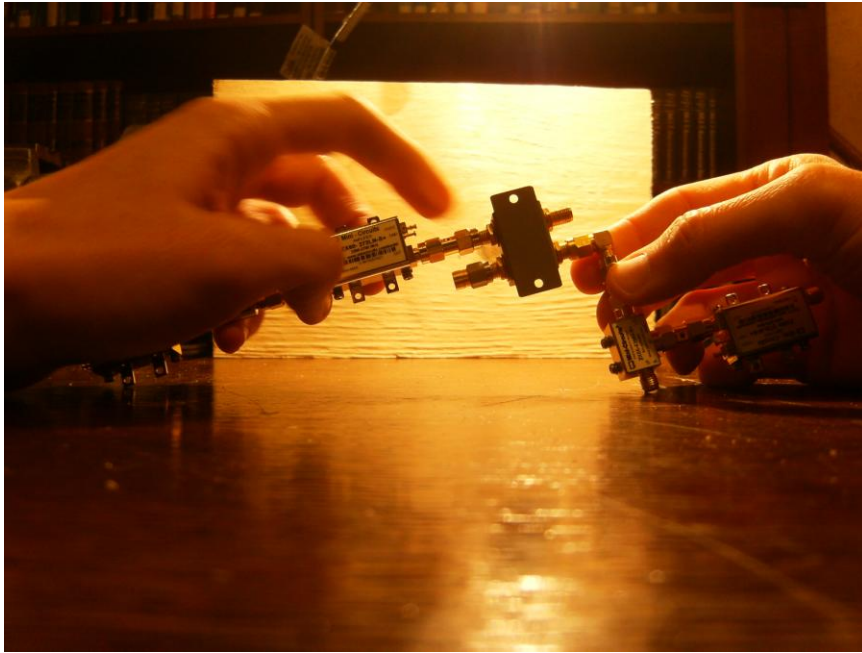

- Thread the SMA-SMA from the output of PA1 onto the input of SPLTR1 (note: SPLTR1 shown in the above image is different in appearance than the one in the kit)
- Now the microwave components should be connected together via the SMA-SMA barrels
- Lay the microwave components down on to the wood block



Fabrication

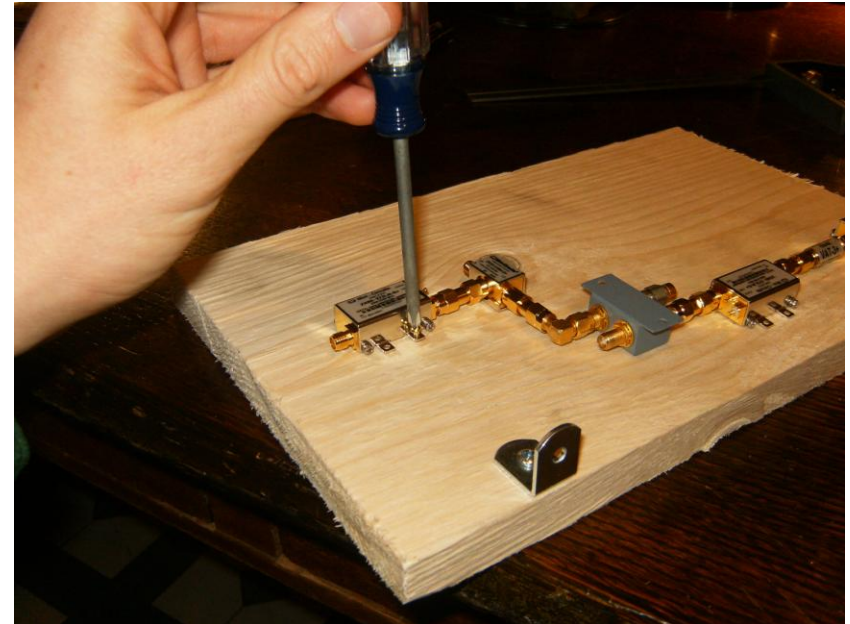
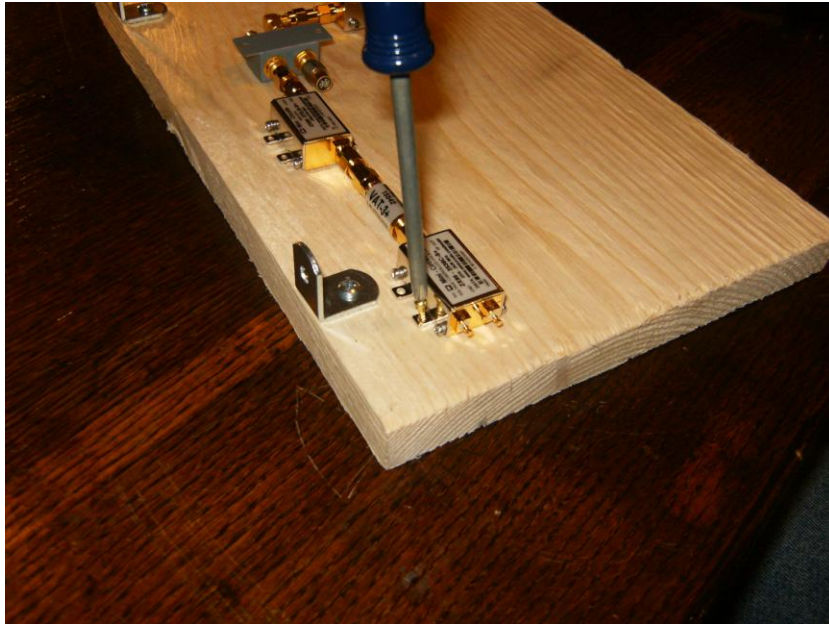

- **Using the #2 wood screws, screw down the microwave components at 2 or more locations along the signal chain**
 - screw holes are located on OSC1, PA1, or LNA1
 - be sure to leave room for the L brackets that will hold Antenna1 and Antenna2



Fabrication

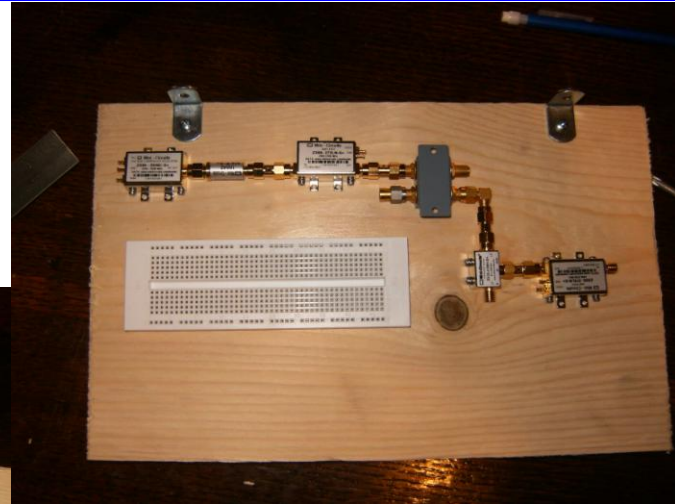
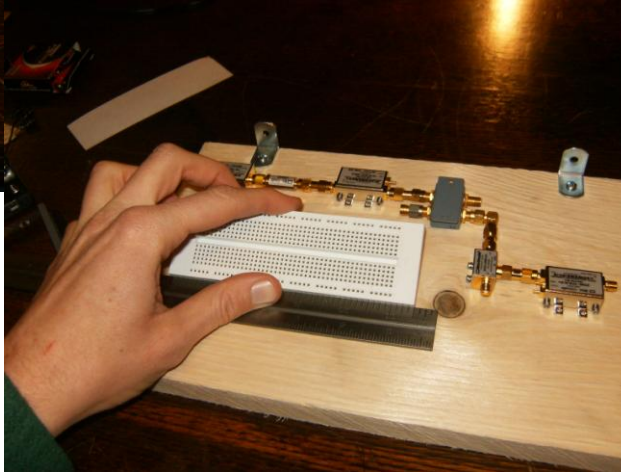
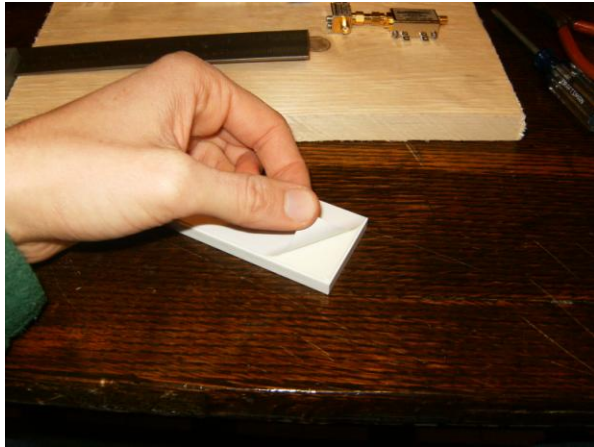

- Find the solderless breadboard
- The bottom of this breadboard has a peel-and-stick backing
 - Peel off the protective layer over the adhesive
 - Stick the breadboard to the wood just below OSC1-ATT1-PA1 components



Fabrication

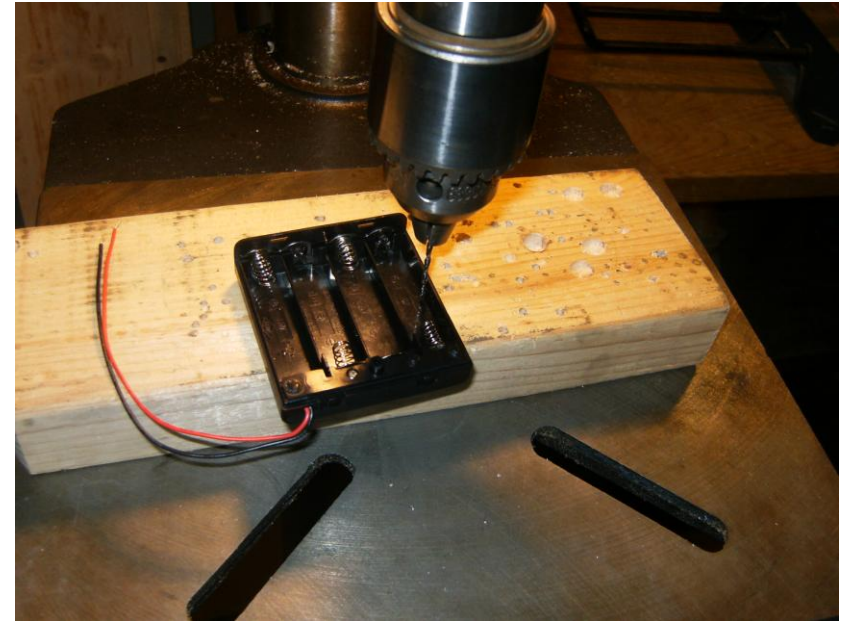
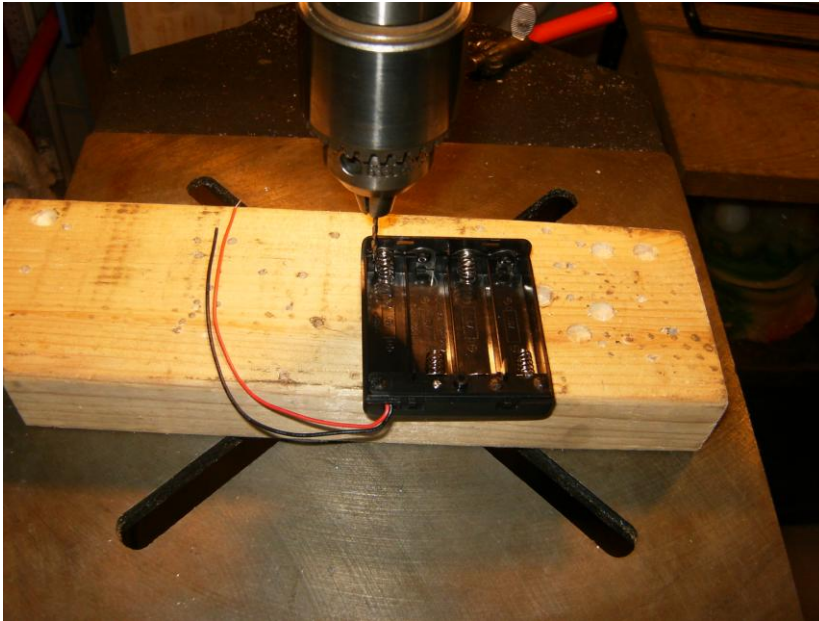

- Find the two battery packs, each holds 4x AA batteries
- Remove front covers of both battery packs
- Drill two small holes on each corner of each of the battery packs
 - make sure the drill bit is just slightly wider than your #2 wood screw threads

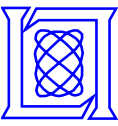

Fabrication



- **Place the battery packs just below the solderless breadboard**
 - make sure that the small power switch on the back side of each battery pack sits over the edge of the wood block
- **Mount the battery packs to the wood block using your #2 wood screws**
 - drive screws into the wood through the mounting holes you drilled in the previous step



Fabrication

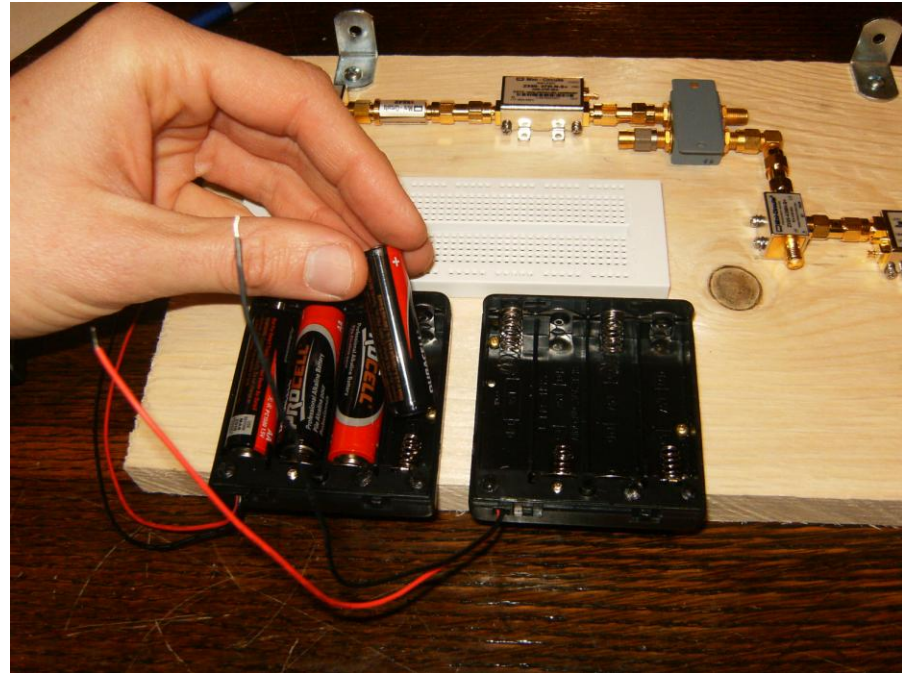
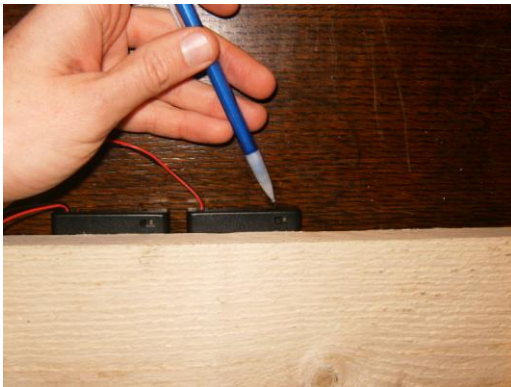
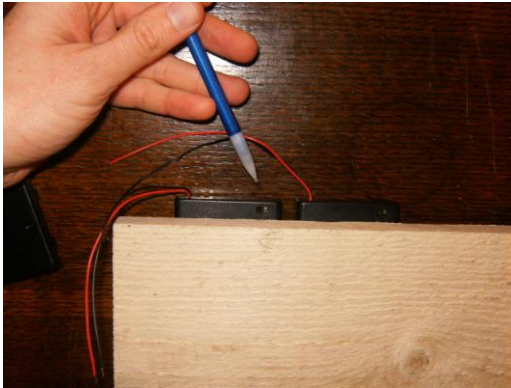

- **Check to make sure the power switches are off for each battery pack**
 - use these switches to turn the radar on and off
- **Insert 8 AA batteries into the battery packs**



Fabrication

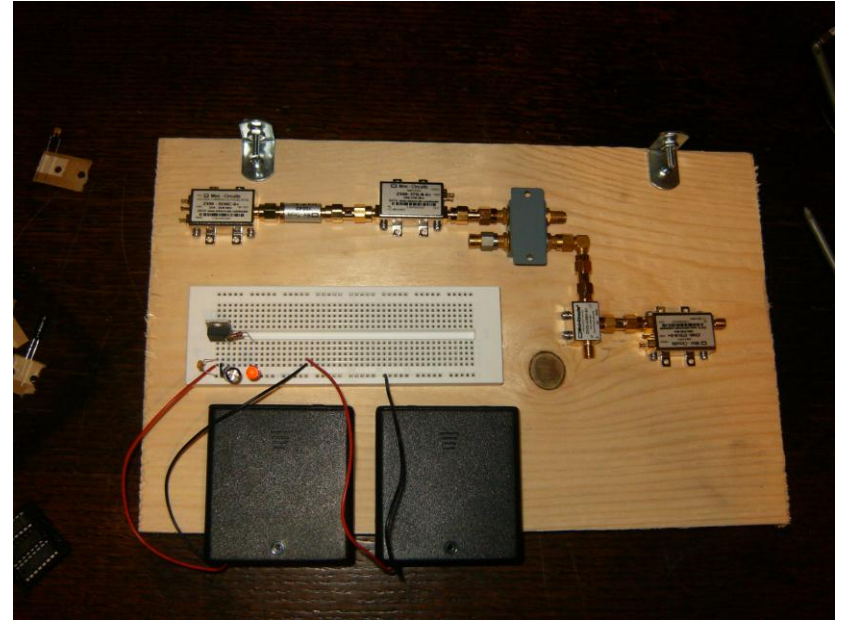
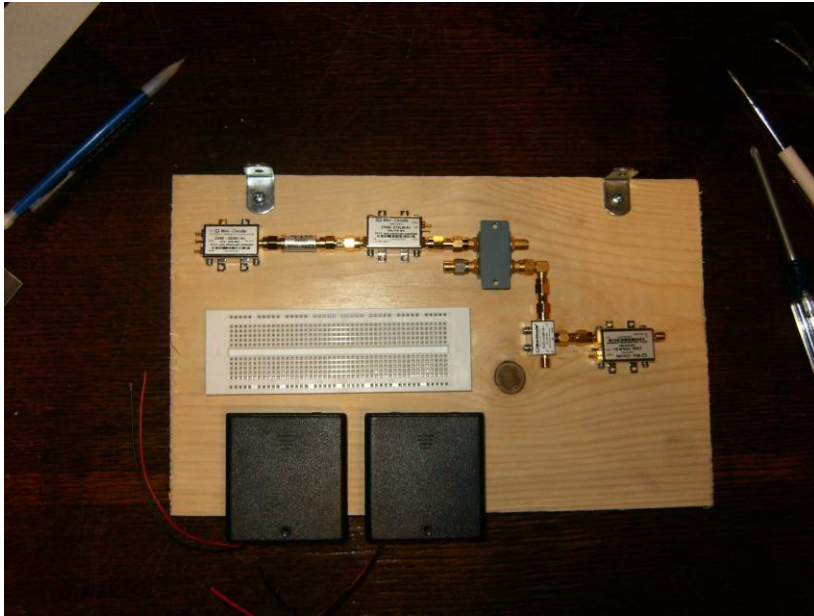

- **Place the lids on the battery packs**
- **Build the power supply circuit on the solderless breadboard from Slide #12**
 - **turn on both power switches on the battery packs**
 - **using a volt meter verify +5V and +5V**

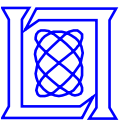

Fabrication

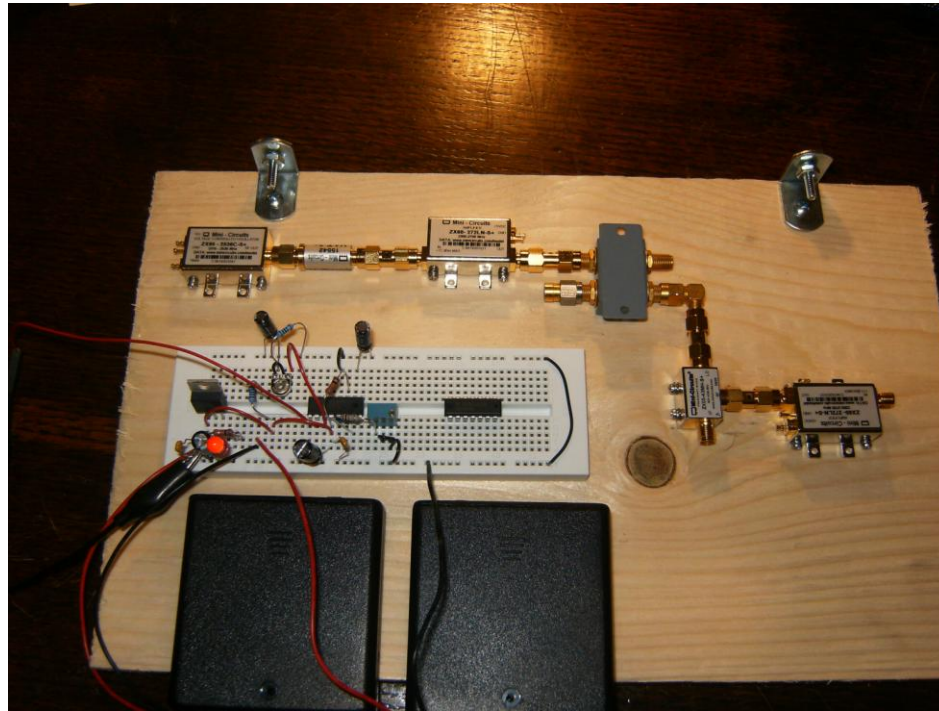

- **Build Modulator1 from Slide #11 on the solderless breadboard**
- **Test ramp output and synchronization output using an oscilloscope**
- **Using the oscilloscope adjust Modulator1 to 20 ms up-ramp time and 5V magnitude**

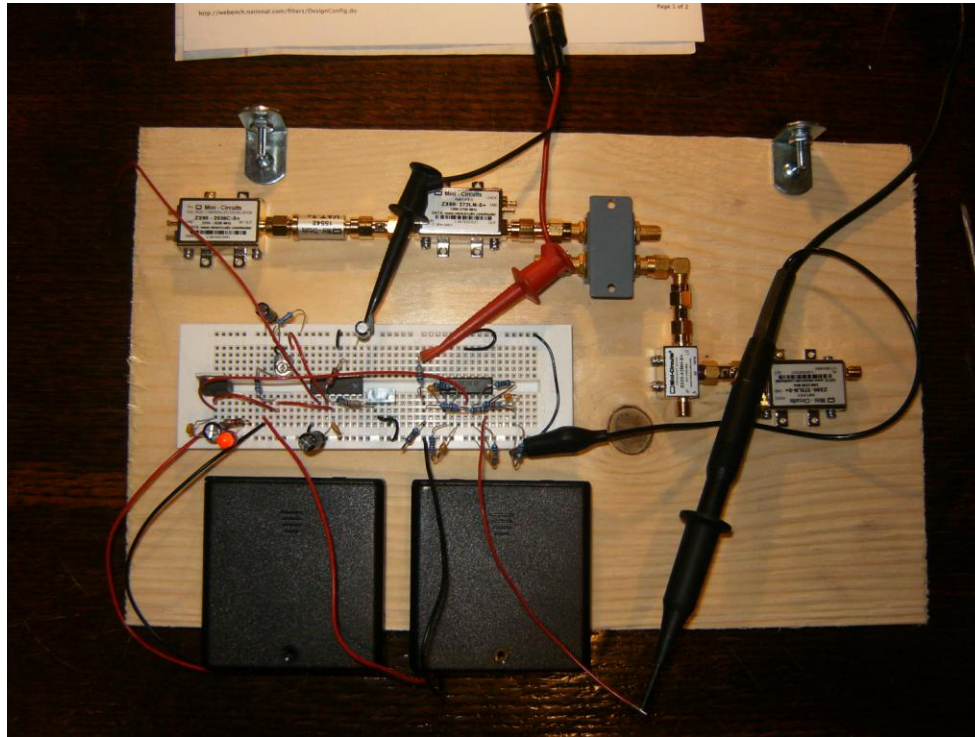

- **Build the active filter stage of Video Amp1 from Slide #10 on to the solderless breadboard**
 - test by connecting a sin wave generator to the input and a 2 channel scope to the output and input
 - verify -3dB roll-off at 15 KHz and steeper roll-off above 15 KHz

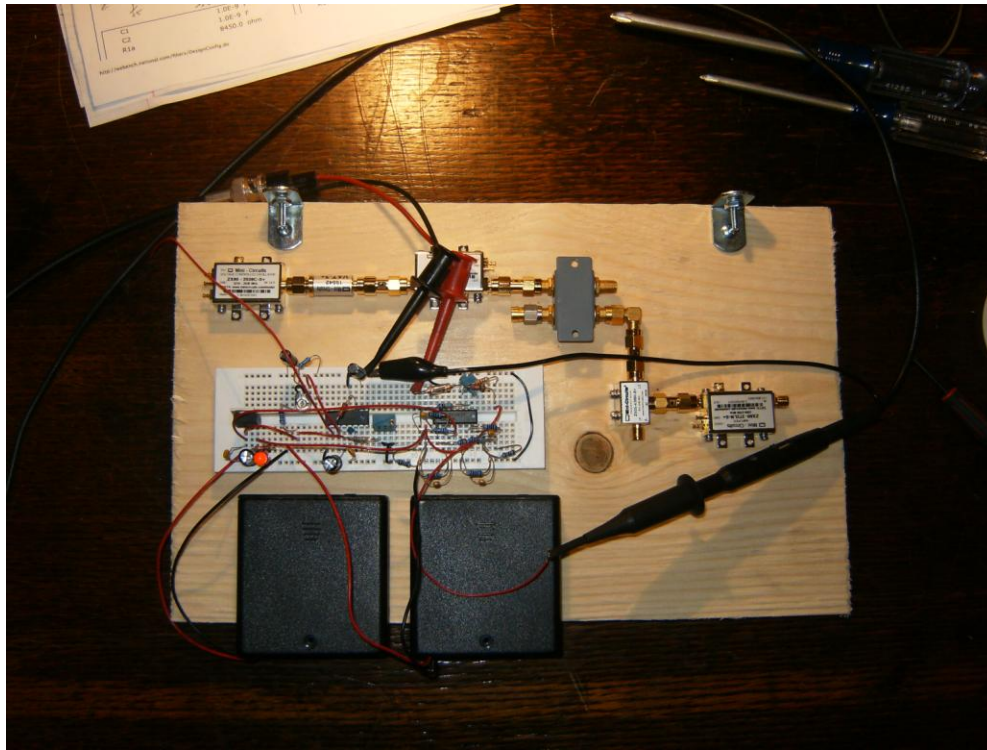
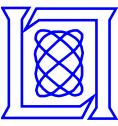

- **Build the gain stage of Video Amp1 from Slide #11 on to the solderless breadboard**
 - connect a function generator to the input and a 2 channel scope to both the input and output, verify gain
 - if works, connect the output of the gain stage to the input of the active LPF



Fabrication

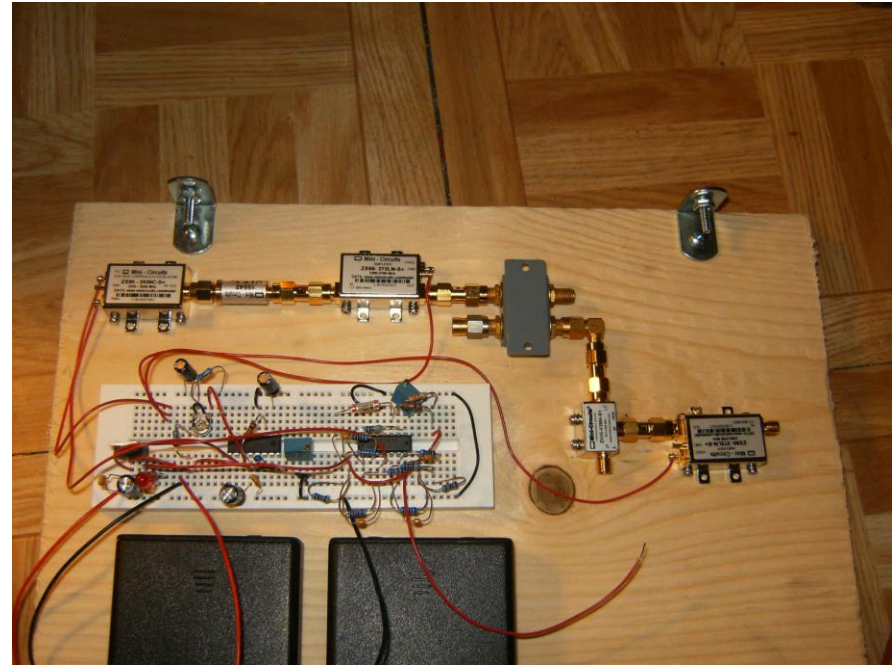
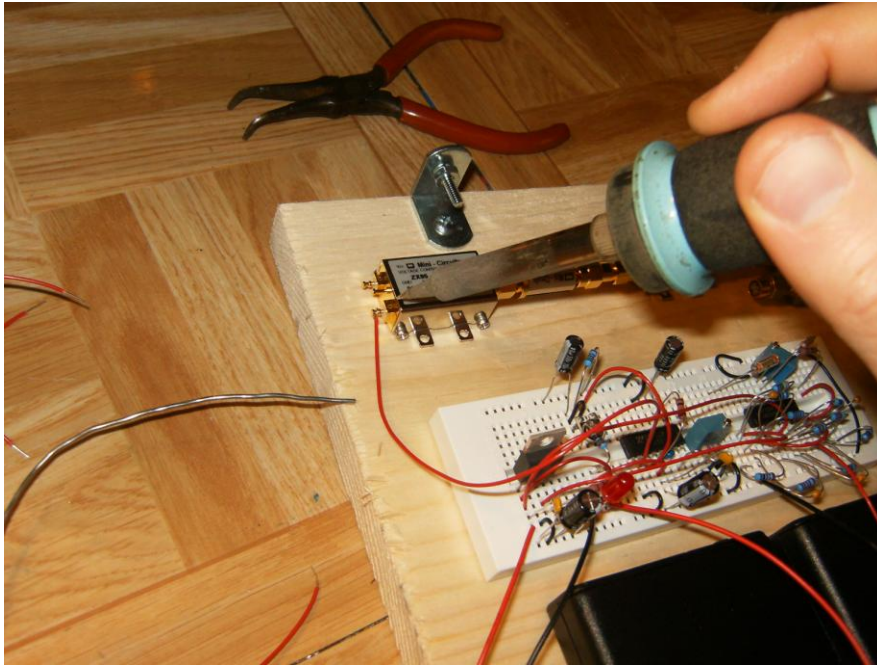

- **Solder power connections to the Vcc or +5 VDC pins on OSC1, PA1, and LNA1**
 - wire these to the output of the 5V regulator

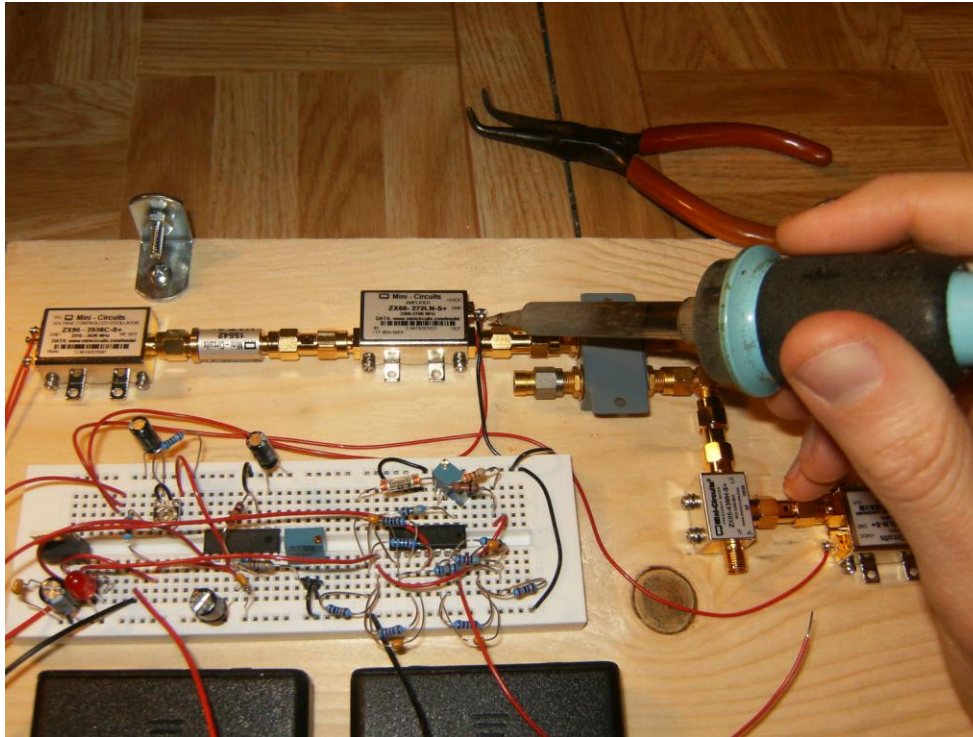

- **Solder a ground wire to the ground terminal of one of the microwave modules**
 - in this case, I have chosen PA1, but it does not matter which is chosen
 - connect this ground wire to the ground bus on the solderless breadboard

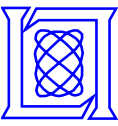

Fabrication



- **Cut one of the SMA-SMA coaxial cables in half, this will be used to feed the IF output of MXR1 to Video Amp1 on the solderless breadboard**
- **Strip the insulation off the end to the shield**
- **Strip off some shield to reveal the center conductor**
- **Strip off insulation from the semiconductor**
- **Solder a piece of single-stranded hook-up wire around the shield of the coax**



Fabrication

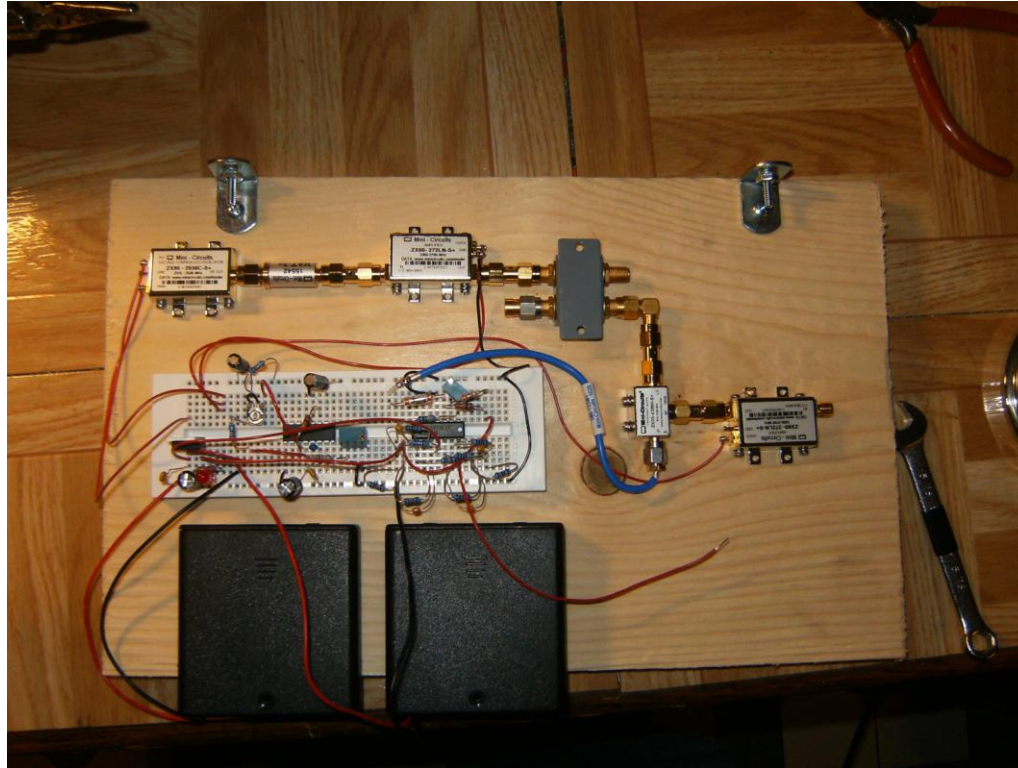

- Thread the SMA to Video Amp1 cable onto the IF port of MXR1
- Connect the shield on the other end to the ground bus of the solderless breadboard
- Connect the center of the coax to the input to the Video Amp1 circuit

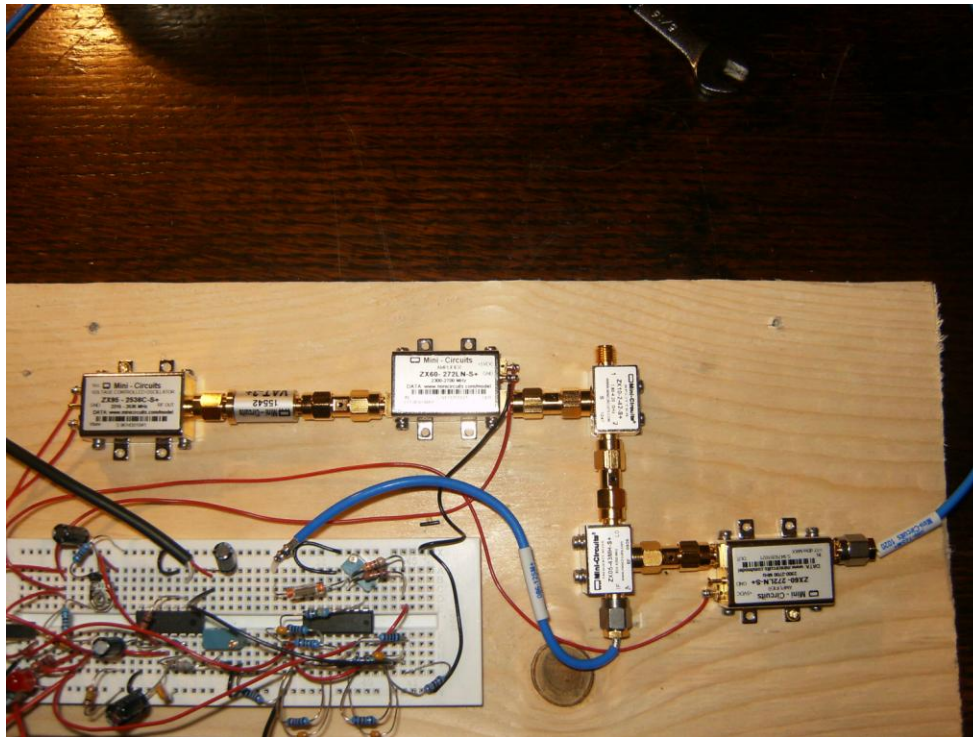

- When complete, the layout of the microwave components should look like this (when using the correct power splitter)
- If available, connect a spectrum analyzer to the un-used output port of SPLTR1 to check transmit bandwidth

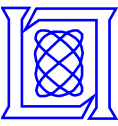

Fabrication

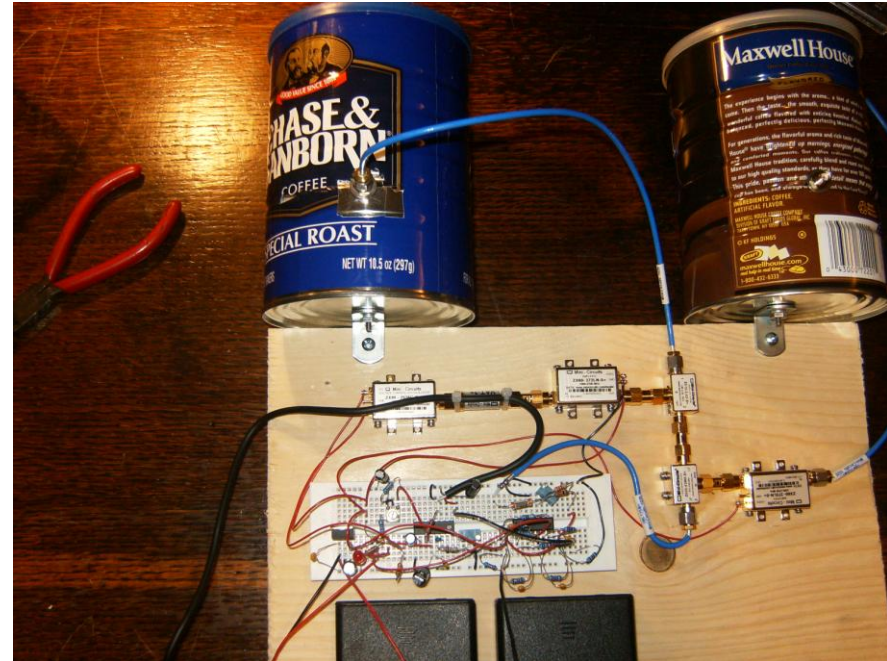
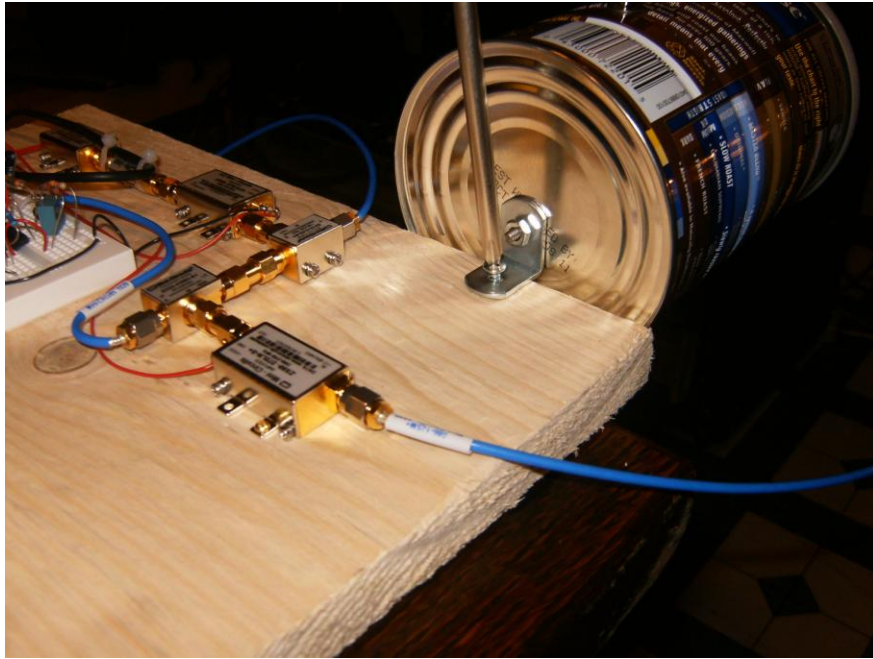

- **Mount Antenna1 and Antenna2 on to the wood block by using two #6 wood screws $\frac{1}{2}$ in length, one for each L bracket**
 - these #6 wood screws are not in the BOM, however, they can be purchased at the Home Depot or any local hardware store

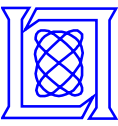

Fabrication

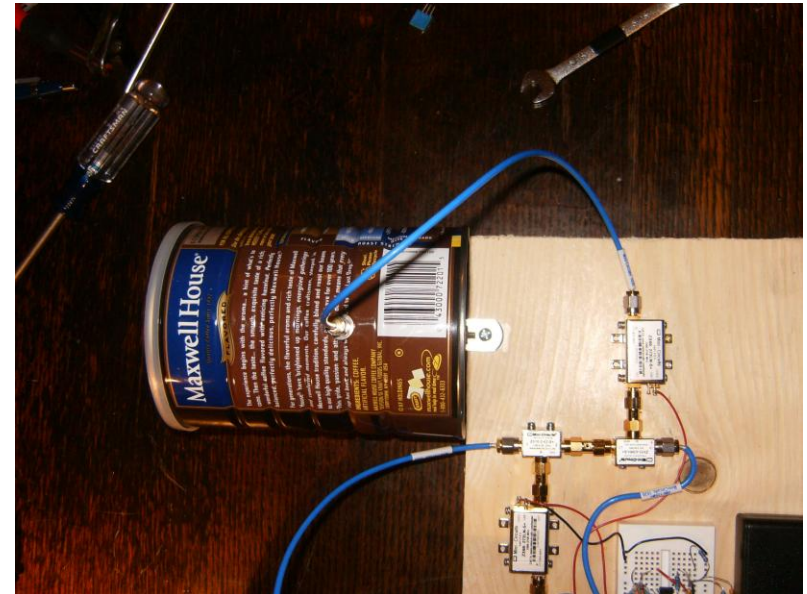

- **Connect the receive antenna by connecting the input to LNA1 to Cantenna2 using an SMA-SMA coaxial cable**
- **Connect the transmit antenna by connecting the un-used output from SPLTR1 to Cantenna1 using an SMA-SMA coaxial cable**



Fabrication

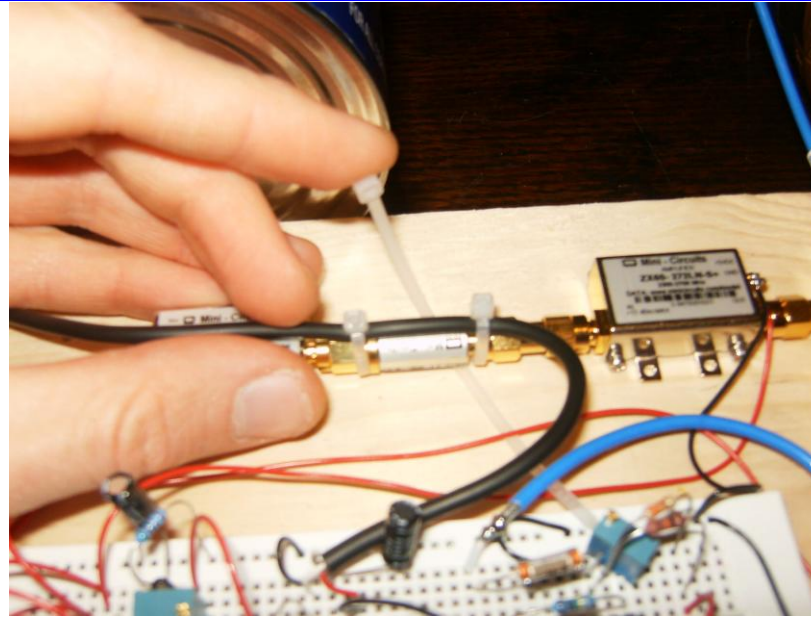

- **Connect the audio cable to the solderless breadboard**
 - red = right channel is fed to the output of Video Amp1
 - white = left channel is fed to the Sync output of Modulator1
 - shield is connected to the ground bus of the solderless breadboard
- **Once connected, wire tie the audio cable on to ATT1 so that the audio cable will not be easily pulled out of the solderless breadboard**



Fabrication

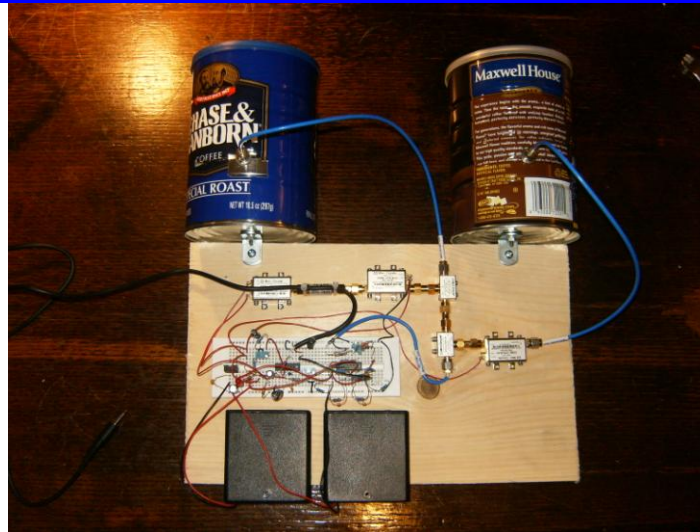

- **Radar kit is now complete**
- **Test by connecting a scope to the video output**
 - see if waveform output changes depending on what is in front of radar
- **If works, then follow the course material to perform**
 - doppler velocity measurements
 - range-time measurements
 - **SAR imaging**



- **Motivation**
- **Fully Assembled Radar Kit**
- **Block Diagram**
- **Schematics**
- **Bill of Material (BOM)**
- **Step-by-Step Fabrication Instructions**
- **How to use the radar**

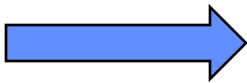



Radar Kit: Doppler vs. Time

1. Bias Vtune to CW (some DC value where you want your center frequency)
2. Connect to audio input of laptop
3. Open 'Sync Pulse Inhibit' switch
4. Deploy radar near moving targets
5. Record .wav file of input audio
6. Process using read_data_doppler.m
 - parses .wav into 4410 sample blocks
 - plots the log magnitude of the IDFT of each block

Tremont street near Newton corner

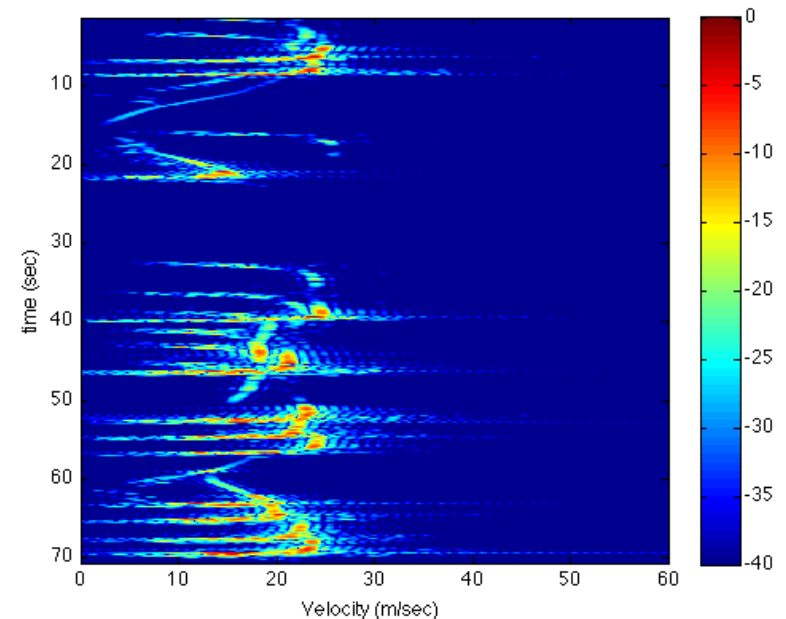

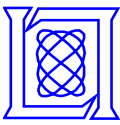

Radar Kit: Ranging vs. Time

1. Re-connect Vtune to modulator output.
2. Set up-ramp duration to 20 ms, adjust magnitude to span desired transmit bandwidth.
3. Deploy radar
4. Record a .wav file.
5. Process .wav using read_data_RTI.m
 - Looks for rising edges of sync pulse on Left channel
 - Saves 20 ms of Right channel data from rising edge, puts into array of de-chirped range profiles
 - Coherently subtracts the last range profile from the current one (2-pulse canceller)
 - Displays the log magnitude of the IDFT of the result as a range-time-indicator (RTI) plot

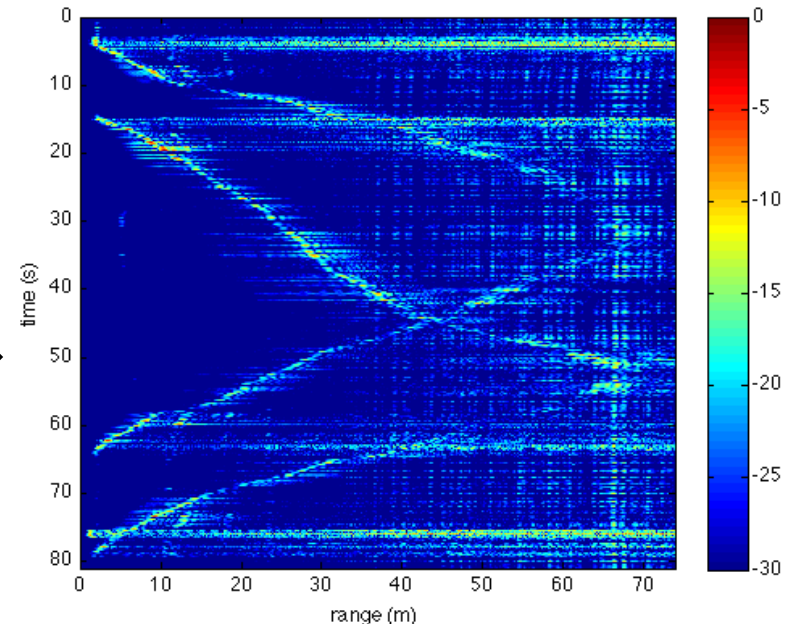
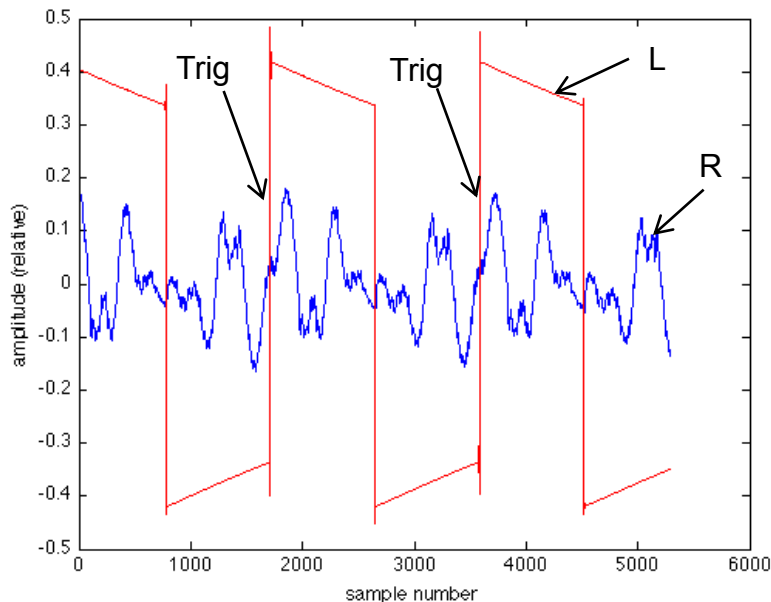



Radar Kit: SAR Imaging

- Record .wav continuously
- Acquire range profiles at 2" increments over 8-10' of aperture length
- Use toggle switch to blank L sync channel, indicating change in radar position
- SBAND_RMA_opendata.m to process .wav file into SAR image, looking for gaps in sync pulses indicating new radar position

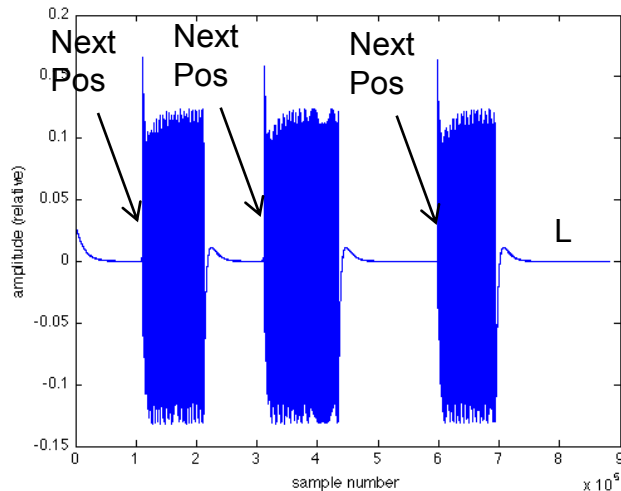
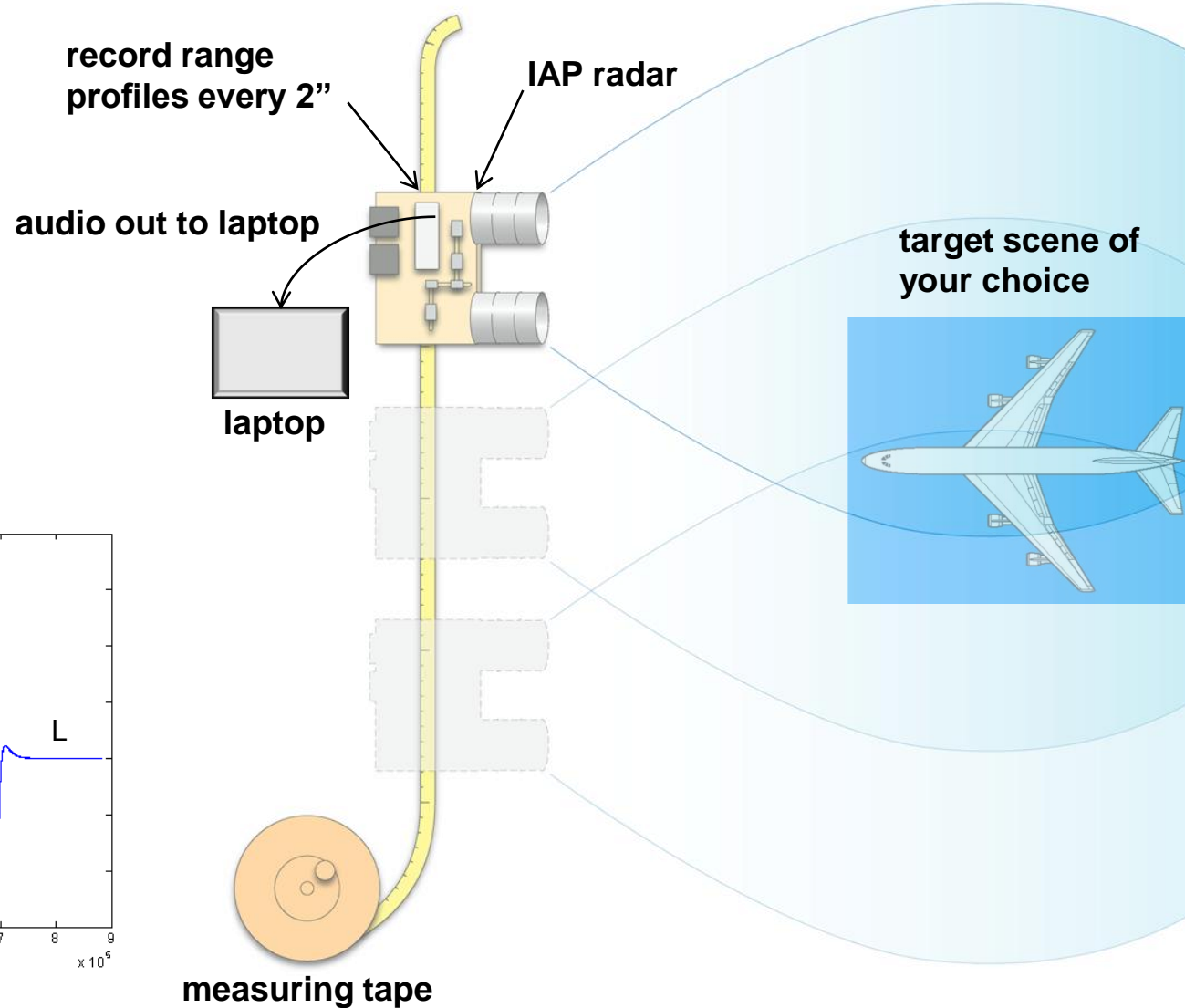



SAR Example: Back of Warehouse

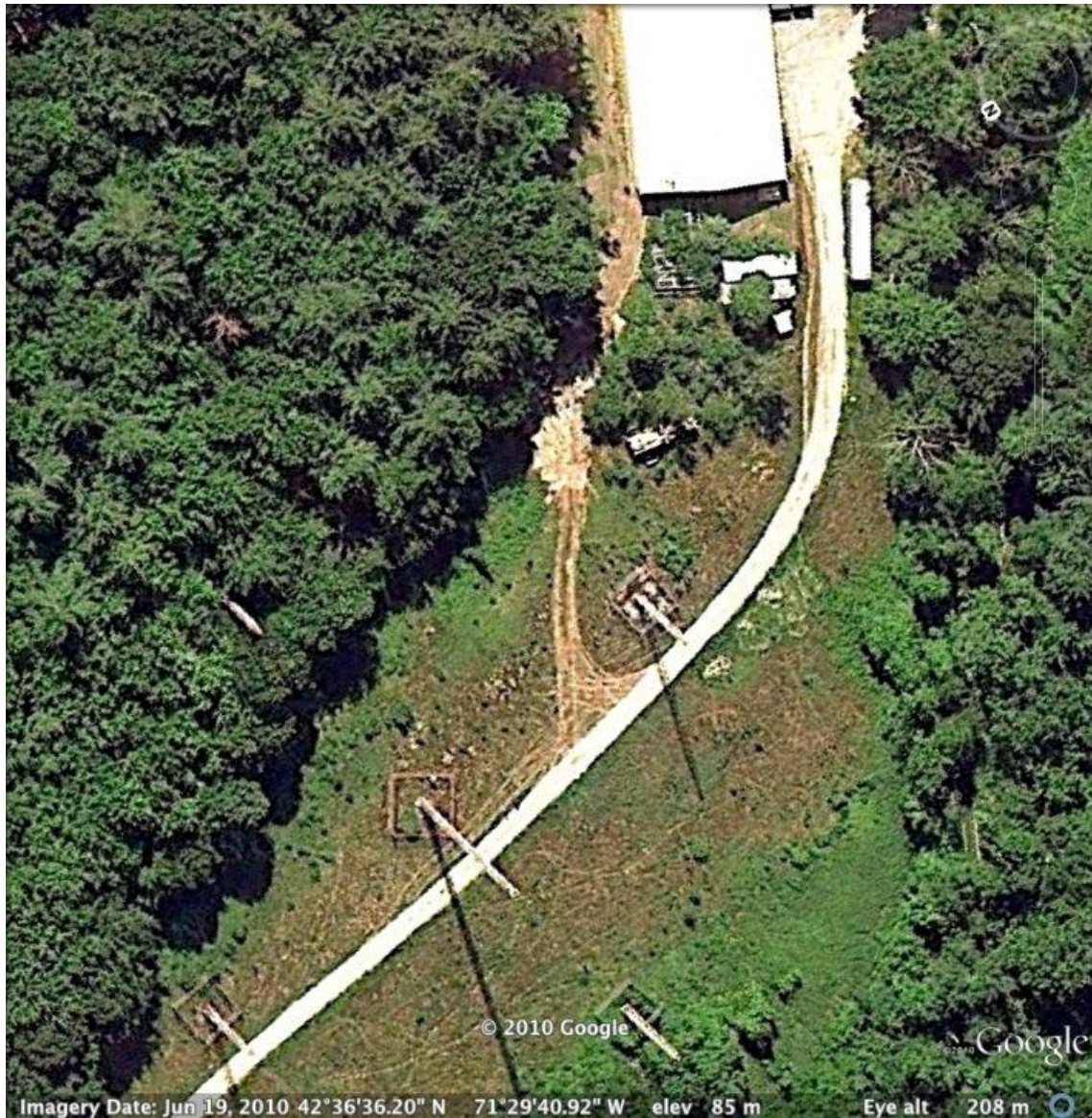



SAR Example: Back of Warehouse

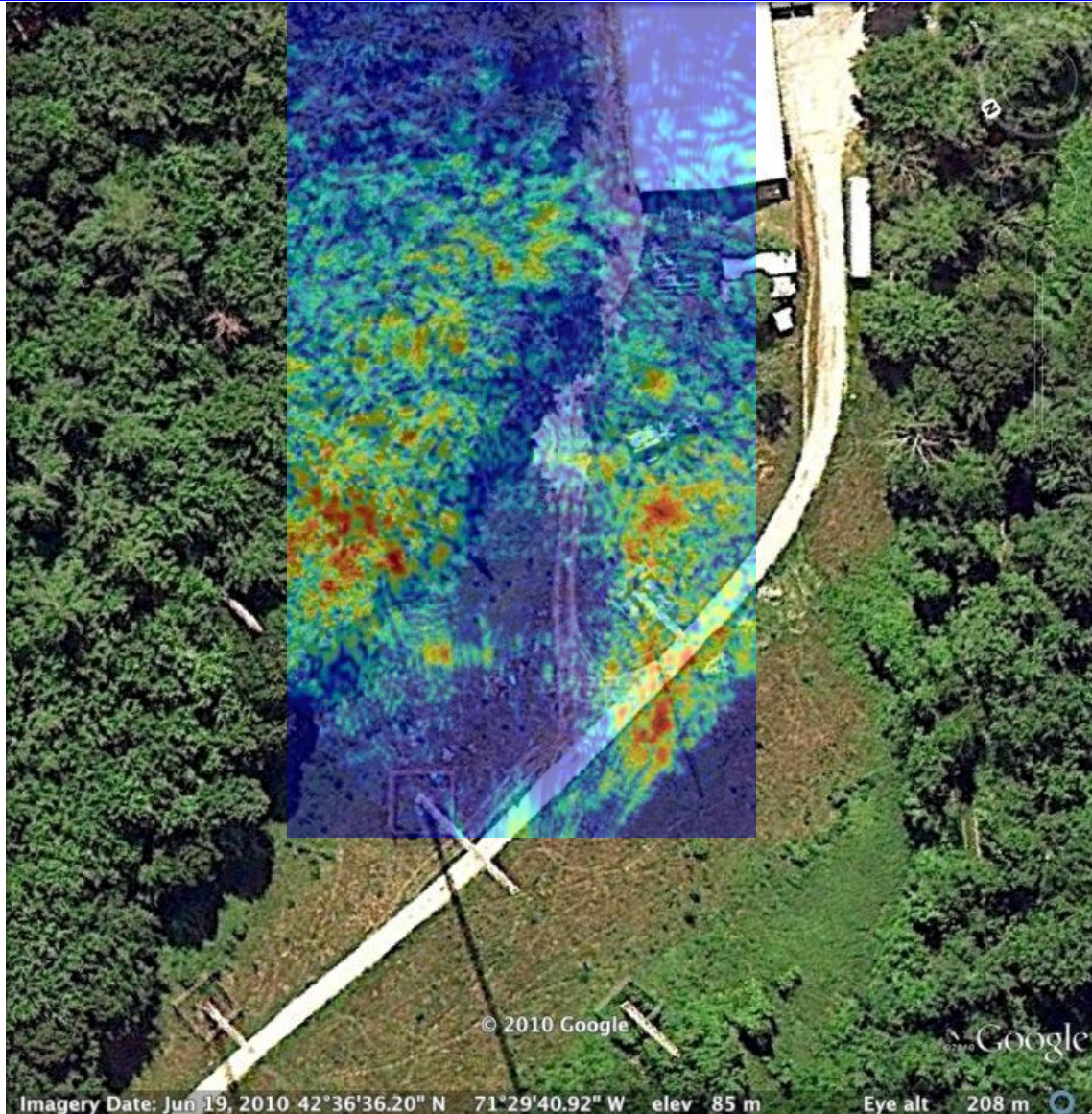



SAR Example: Back of Warehouse

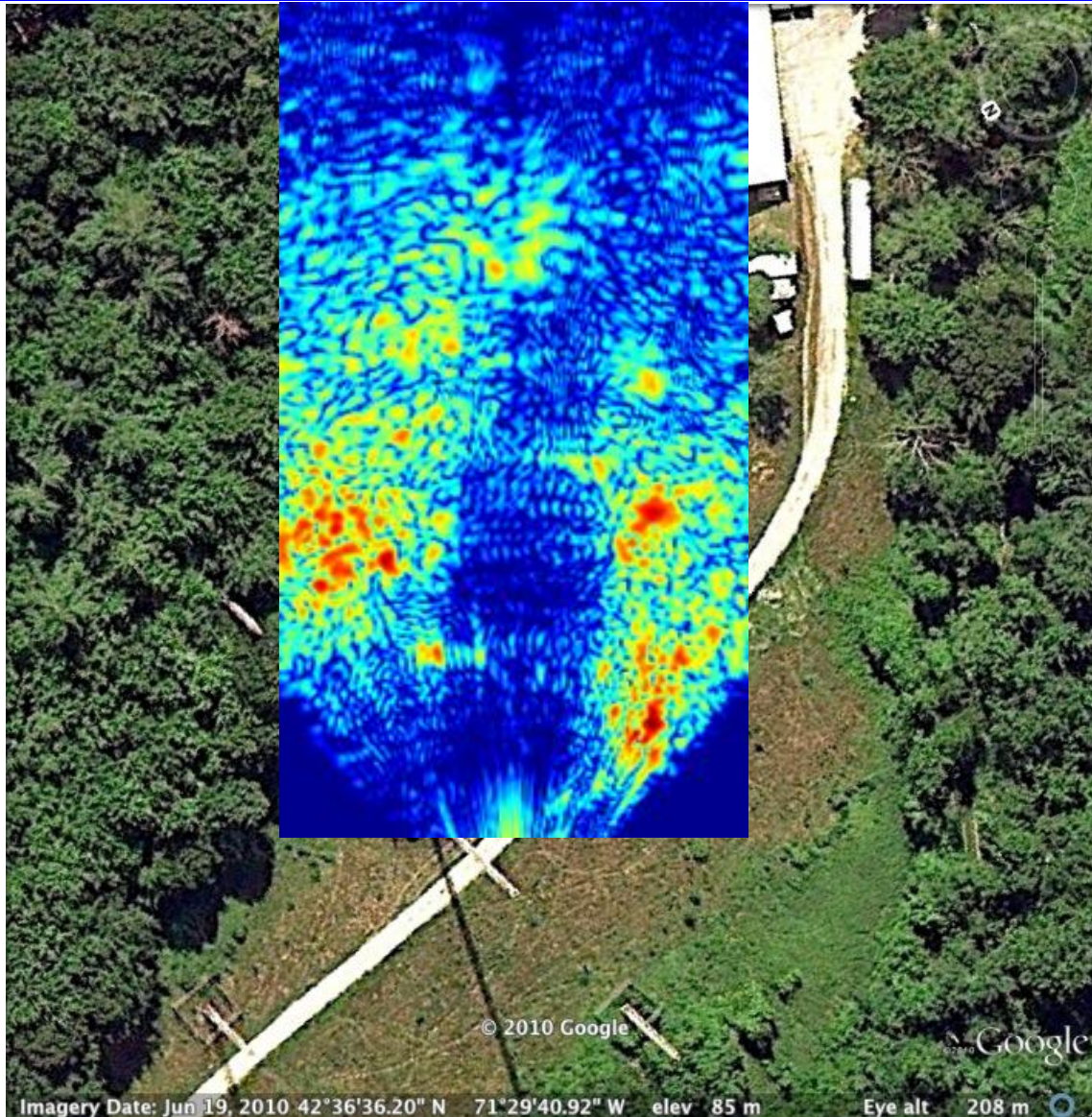

MIT OpenCourseWare
<http://ocw.mit.edu>

Resource: Build a Small Radar System Capable of Sensing Range, Doppler, and Synthetic Aperture Radar Imaging
Dr. Gregory L. Charvat, Mr. Jonathan H. Williams, Dr. Alan J. Fenn, Dr. Steve Kogon, Dr. Jeffrey S. Herd

The following may not correspond to a particular course on MIT OpenCourseWare, but has been provided by the author as an individual learning resource.

For information about citing these materials or our Terms of Use, visit: <http://ocw.mit.edu/terms>.