



Dynamic Sciences International, Inc.

Application Note

DSI-600 EMI TEST MEASUREMENT RECEIVER SYSTEM

Subject: Tracking

Application Note No. 2.01:

Frequency Tracked Measurements

Swept Tracked Frequency Measurements

Frequency selective devices such as amplifiers, filters, directional couplers, attenuators and the like, are characterized by their performance versus frequency.

Measuring these characteristics, during development or for inspection is performed by various methods, most are frequency swept. Sweeping the frequency provides a convenient comparison between the specified and measured characteristic.

The high-end of swept frequency measurements, are performed by vector network analyzers. These systems provide phase and amplitude versus frequency of device characteristics, such as S-parameters. The cost of vector network analyzers, especially at the high end of the microwave frequency band is very high, and can run into the hundreds of thousands of dollars. These systems are used mainly by research and development companies, for the development of frequency selective devices.

When the required characteristic is amplitude versus frequency only, simpler and cheaper methods are available, with tracking signal generators being the commonest.

Tracking generators are signal sources with their frequency controlled by a frequency sweeping receiver or spectrum analyzer. The typical block diagram of such a system is given in figure 1:

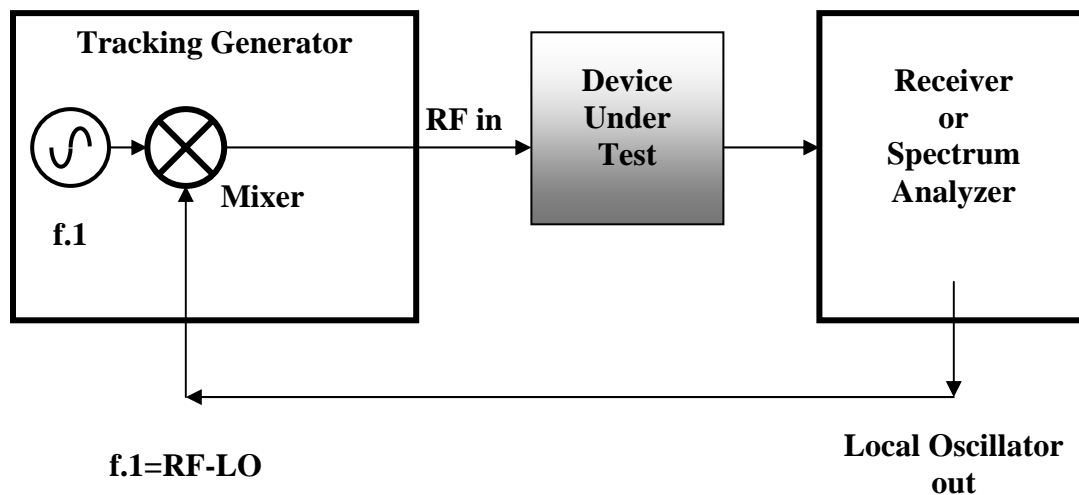

Figure 1. Basic setup for swept frequency measurement using a tracking signal generator

The measurement of the amplitude versus frequency characteristics of the device, are typically relative values such as attenuation. The measurement involves a two step procedure:

1. The tracking generator is connected directly to the receiver or spectrum analyzer, and a base line or reference level is obtained by sweeping through the frequency band of interest. This base /reference line is stored in the receiver/spectrum analyzers memory.
2. The amplitude settings of the tracking generator are left unchanged from step 1, and the device is inserted as in figure 1. The measurement is now repeated. The result is stored in the receiver/spectrum analyzer's memory.

The ratio or difference in dB between the results of step 2 and 1 are the desired characteristic, amplitude versus frequency of the device.

The accuracy of this type of measurement is governed by the accuracy of the amplitude measurement of the receiver or spectrum analyzer, which is typically ± 2 dB, but more so by the accuracy of the frequency match between the tracking signal generator and that of the receiver or spectrum analyzer.

In the case of the setup of figure 1, the frequency match accuracy is governed by the accuracy of the frequency of the internal oscillator in the tracking generator, f_1 . This accuracy requirement is especially important when measuring narrow band devices such as filters, and especially those with steep slopes, such as band pass or band stop filters. Inaccuracy in the frequency match (RF in versus the tuned frequency of the receiver or spectrum analyzer), will result in erroneous results in the measurement of the steep slope characteristics.

The accuracy of typical spectrum analyzers is $\pm 2\%$, and that of quality tracking generators, about the same, so filters with slopes of 70dB / Decade of frequency, such a frequency accuracy may result in unacceptable errors , which may cause a good filter to be rejected, as in figure 2:

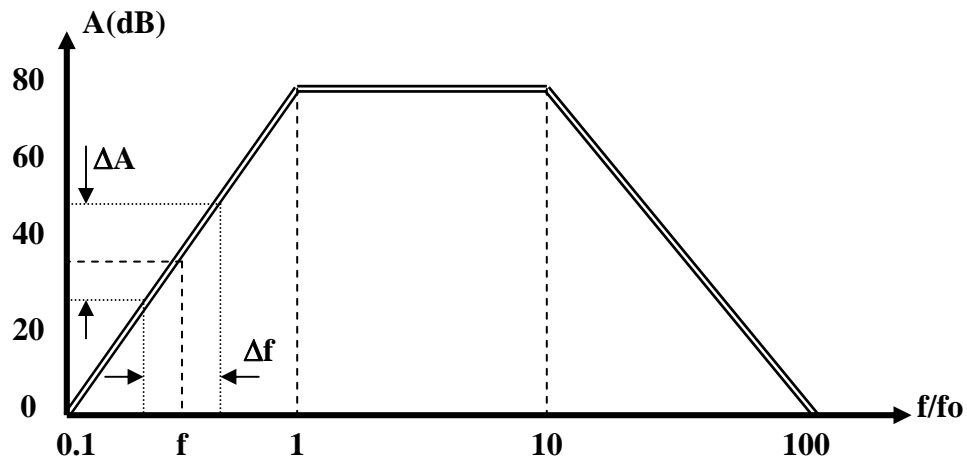

Figure 2. Measurement inaccuracy of the characteristics of a band-stop filter

In this example, an inaccuracy (Δf) of +/-2% in frequency, or a total of 4% (for the sum of the inaccuracies of the two measurements, calibration and test), will result in an amplitude error of:

$$\Delta A = 70\text{dB/Decade} * \Delta f = 70 * 0.04 = 2.8\text{dB}.$$

When this inaccuracy is added to the inherent inaccuracy of the amplitude measurement of the receiver or spectrum analyzer of +/-2dB, this error may be unacceptable, especially when the tolerance of the specifications of the device are tighter than the measurement error.

The Dynamic Sciences International Frequency tracking Technique

The capability of the DSI Receivers solves this problem by using a unique frequency tracking technique that is insensitive to the accuracy of the tracking signal generator, and relies only on the frequency accuracy of the receiver.

The setup for a swept frequency tracking measurement using the DSI method is given in figure 3:

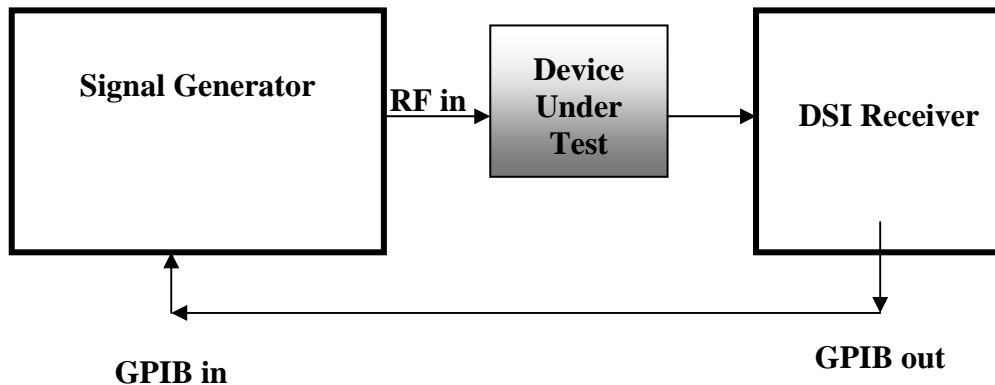

Figure 3. Swept frequency tracking with a DSI Receiver

The frequency of the DSI Receiver is stepped according to the requirements of the measurement. In the case of frequency tracking measurements, the receiver dictates the frequency of the signal generator, using a GPIB data link to set the required frequency. This frequency is now generated by the signal generator with the accuracy of that signal generator, [which with the signal generators available at reasonable cost, are very accurate.](#)

[Hence, the tracking measurements with the signal generator controlled by the receiver via a GPIB link, the measurements are reasonably accurate, and at a reasonable cost.](#)

An even cheaper method for “tracking” using a very cheap signal source, non GPIB controlled, with a manually set sweep rate option can be done using the DSI receiver in the sweep mode, by having the sweep generator at a rate slower than that of the receiver.

The DSI Receiver now step-sweeps across the desired frequency, covering the expected location of the center frequency of the signal generator and provides a reading of the amplitude with the accuracy of the receiver, as depicted in figure 4:

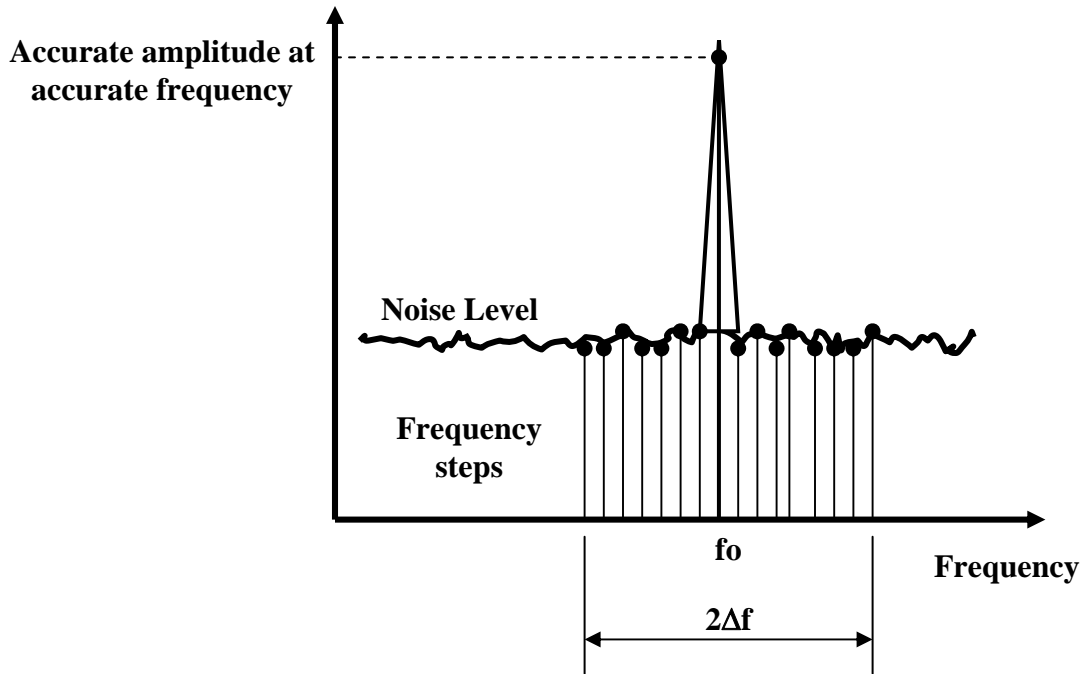

Figure 4. The DSI technique for cheap frequency “tracking” measurements

The resultant plot over the desired frequency range is that of a “picket fence” rather than a linear curve as obtained by other methods of swept measurements. This display can be programmed to appear linear by mathematical interpolation, as in figure 5:

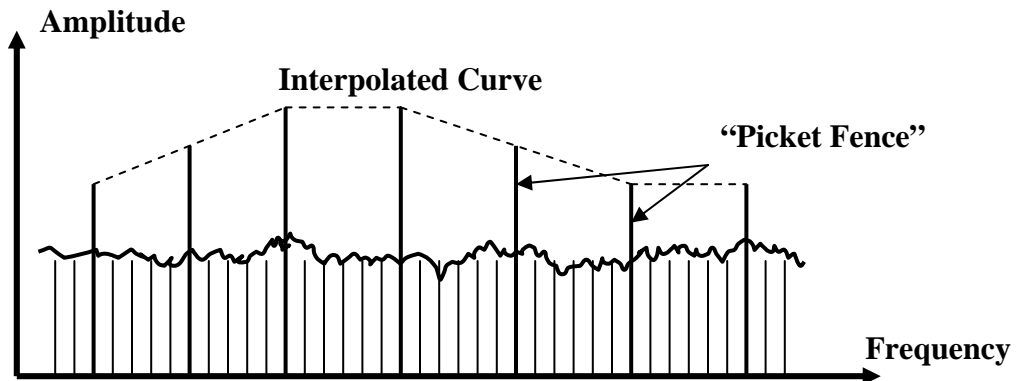

Figure 5. Display of “tracked” frequency measurement using the DSI Technique

Benefits of the DSI Tracked Frequency Technique

With the DSI Technique, swept frequency tracking measurements can be made with a high degree of frequency accuracy, without the need to use an expensive tracking signal generator. Any reasonably stable signal generator with a GPIB control will suffice.

Any Quality EMC Laboratory and RF Product development establishment requires sensitive measurement equipment in a wide frequency range, for testing and quality control of its products and purchased components for its products. The DSI Receiver provides both the measurement capability required for such applications, and the frequency tracking capability in the same Receiver, as a cost effective solution.