

THE BIG BOOK OF MISCHIEF 1.2 7-29-91  
[This file replaces TBBOM11.ZIP/ TBBOM11.TXT]

## Preface

A couple of years ago, I began compiling a file filled with information from the world-famous BBS Ripco. The basis of this file was, of course, THE TERRORIST'S HANDBOOK, an incredible book that was never published. Ripco fell prey to Operation Sundevil. I printed out two copies of this file: Both went to friends. These are the only copies of the original version of this file in existence. I suffered a hard disk crash which wiped out the subdirectory in which my original file resided. Today, August 8th, 1990, at 1 AM, I found a copy of The Terrorist's Handbook on a BBS, and recombined it with some other G-files. Hope you like it. And remember, the First Amendment is not a shield. Care must be taken to ensure that no law is broken when information is gained or divulged. I have read every word of this file, and swear that no article of this document is illegal in any way.

The Editor

4/12/91 -- New guideline: If you modify this file, please put the date and info about modifications in the revision history. This is to keep the new versions of the file in order, to aid updating.

## Revision history:

-----  
1987-1989           Compilation of original file  
Early 1990           Original file lost in crash  
August 8, 1990       File reborn as The Compleat Terrorist  
March 31, 1991       In February, I had a major loss of data, but regained TCT from a local BBS. I did some cosmetic work and killed some redundancies, and renamed the file to TBBOM. Total file size is now about 172 printed pages. (You may wish to print this file out and bind it in a binder)  
April 12, 1991       File revised by David Richards on Ripco II. Some deletions and many valuable additions. Message about new additions added to preface. I (The Editor) felt that the file should have version numbers, so, in light of the additions by David Richards, the first volume number is 1.1.  
July 29, 1991       Revisions and addenda by Vlad Tepes. A revision is a change in the information (The original text is immediately followed by the new information) and an addendum refers to new information.

## THE BIG BOOK OF MISCHIEF

PART 1 - The Terrorist's Handbook - Self explanatory.

### THE TERRORIST'S HANDBOOK

#### 1.0 INTRODUCTION

Gunzenbomz Pyro-Technologies, a division of Chaos Industries (CHAOS), is proud to present this first edition of The Terrorist's Handbook. First and foremost, let it be stated that Chaos Industries assumes no responsibilities for any misuse of the information presented in this publication. The purpose of this is to show the many techniques and methods used by those people in

this and other countries who employ terror as a means to political and social goals. The techniques herein can be obtained from public libraries, and can usually be carried out by a terrorist with minimal equipment. This makes one all the more frightened, since any lunatic or social deviant could obtain this information, and use it against anyone. The processes and techniques herein SHOULD NOT BE CARRIED OUT UNDER ANY CIRCUMSTANCES!! SERIOUS HARM OR DEATH COULD OCCUR FROM ATTEMPTING TO PERFORM ANY OF THE METHODS IN THIS PUBLICATION. THIS IS MERELY FOR READING ENJOYMENT, AND IS NOT INTENDED FOR ACTUAL USE!!

Gunzenbomz Pyro-Technologies feels that it is important that everyone has some idea of just how easy it is for a terrorist to perform acts of terror; that is the reason for the existence of this publication.



- 4.0 ..... USING EXPLOSIVES
- 4.1 ..... SAFETY
- 4.2 ..... IGNITION DEVICES
  - 4.21 ..... Fuse Ignition
  - 4.22 ..... Impact Ignition
  - 4.23 ..... Electrical Ignition
  - 4.24 ..... Electro - Mechanical Ignition
  - 4.241 ..... Mercury Switches
  - 4.242 ..... Tripwire Switches
  - 4.243 ..... Radio Control Detonators
- 4.3 ..... DELAYS
  - 4.31 ..... Fuse Delays
  - 4.32 ..... Timer Delays
  - 4.33 ..... Chemical Delays
- 4.4 ..... EXPLOSIVE CONTAINERS
  - 4.41 ..... Paper Containers
  - 4.42 ..... Metal Containers
  - 4.43 ..... Glass Containers
  - 4.44 ..... Plastic Containers
- 4.5 ..... ADVANCED USES FOR EXPLOSIVES
  - 4.51 ..... Shaped Charges
  - 4.52 ..... Tube Explosives
  - 4.53 ..... Atomized Particle Explosions
  - 4.54 ..... Lightbulb Bombs
  - 4.55 ..... Book Bombs
  - 4.56 ..... Phone Bombs
- 5.0 ..... SPECIAL AMMUNITION FOR PROJECTILE WEAPONS
- 5.1 ..... PROJECTILE WEAPONS (PRIMITIVE)
  - 5.11 ..... Bow and Crossbow Ammunition
  - 5.12 ..... Blowgun Ammunition
  - 5.13 ..... Wrist Rocket and Slingshot Ammunition
- 5.2 ..... PROJECTILE WEAPONS (FIREARMS)
  - 5.21 ..... Handgun Ammunition
  - 5.22 ..... Shotguns
- 5.3 ..... PROJECTILE WEAPONS (COMPRESSED GAS)
  - 5.31 ..... .177 Caliber B.B Gun Ammunition
  - 5.32 ..... .22 Caliber Pellet Gun Ammunition
- 6.0 ..... ROCKETS AND CANNONS
- 6.1 ..... ROCKETS
  - 6.11 ..... Basic Rocket-Bomb
  - 6.12 ..... Long Range Rocket-Bomb
  - 6.13 ..... Multiple Warhead Rocket-Bombs
- 6.2 ..... CANNONS
  - 6.21 ..... Basic Pipe Cannon
  - 6.22 ..... Rocket-Firing Cannon
- 7.0 ..... PYROTECHNICA ERRATA
  - 7.1 ..... Smoke Bombs
  - 7.2 ..... Colored Flames
  - 7.3 ..... Tear Gas
  - 7.4 ..... Fireworks
    - 7.41 ..... Firecrackers
    - 7.42 ..... Skyrockets
    - 7.43 ..... Roman Candles
- 8.0 ..... LISTS OF SUPPLIERS AND FURTHER INFORMATION
- 9.0 ..... CHECKLIST FOR RAIDS ON LABS
- 10.0 ..... USEFUL PYROCHEMISTRY
- 11.0 ..... ABOUT THE AUTHOR

## 2.0 BUYING EXPLOSIVES AND PROPELLANTS

Almost any city or town of reasonable size has a gun store and a pharmacy. These are two of the places that potential terrorists visit in order to purchase explosive material. All that one has to do is know something about the non- explosive uses of the materials. Black powder, for example, is used in blackpowder firearms. It comes in varying "grades", with each different grade being a slightly different size. The grade of black powder depends on what the calibre of the gun that it is used in; a fine grade of powder could burn too fast in the wrong caliber weapon. The rule is: the smaller the grade, the faster the burn rate of the powder.

### 2.01 BLACK POWDER

Black powder is generally available in three grades. As stated before, the smaller the grade, the faster the powder burns. Burn rate is extremely important in bombs. Since an explosion is a rapid increase of gas volume in a confined environment, to make an explosion, a quick-burning powder is desirable. The three common grades of black powder are listed below, along with the usual bore width (calibre) of what they are used in. Generally, the fastest burning powder, the FFF grade is desirable. However, the other grades and uses are listed below:

GRADE ÄÄÄÄÄ	BORE WIDTH ÄÄÄÄÄÄÄÄÄÄ	EXAMPLE OF GUN ÄÄÄÄÄÄÄÄÄÄÄÄÄÄ
F	.50 or greater	model cannon; some rifles
FF	.36 - .50	large pistols; small rifles
FFF	.36 or smaller	pistols; derringers

The FFF grade is the fastest burning, because the smaller grade has more surface area or burning surface exposed to the flame front. The larger grades also have uses which will be discussed later. The price range of black powder, per pound, is about \$8.50 - \$9.00. The price is not affected by the grade, and so one saves oneself time and work if one buys the finer grade of powder. The major problems with black powder are that it can be ignited accidentally by static electricity, and that it has a tendency to absorb moisture from the air. To safely crush it, a bomber would use a plastic spoon and a wooden salad bowl. Taking a small pile at a time, he or she would apply pressure to the powder through the spoon and rub it in a series of strokes or circles, but not too hard. It is fine enough to use when it is about as fine as flour. The fineness, however, is dependant on what type of device one wishes to make; obviously, it would be impracticable to crush enough powder to fill a 1 foot by 4 inch radius pipe. Anyone can purchase black powder, since anyone can own black powder firearms in America.

## 2.02 PYRODEX

Pyrodex is a synthetic powder that is used like black powder. It comes in the same grades, but it is more expensive per pound. However, a one pound container of pyrodex contains more material by volume than a pound of black powder. It is much easier to crush to a very fine powder than black powder, and it is considerably safer and more reliable. This is because it will not be set off by static electricity, as black can be, and it is less inclined to absorb moisture. It costs about \$10.00 per pound. It can be crushed in the same manner as black powder, or it can be dissolved in boiling water and dried.

## 2.03 ROCKET ENGINE POWDER

One of the most exciting hobbies nowadays is model rocketry. Estes is the largest producer of model rocket kits and engines. Rocket engines are composed of a single large grain of propellant. This grain is surrounded by a fairly heavy cardboard tubing. One gets the propellant by slitting the tube length-wise, and unwrapping it like a paper towel roll. When this is done, the grey fire clay at either end of the propellant grain must be removed. This is usually done gently with a plastic or brass knife. The material is exceptionally hard, and must be crushed to be used. By gripping the grain on the widest setting on a set of pliers, and putting the grain and powder in a plastic bag, the powder will not break apart and shatter all over. This should be done to all the large chunks of powder, and then it should be crushed like black powder. Rocket engines come in various sizes, ranging from 1/4 A - 2T to the incredibly powerful D engines. The larger the engine, the more expensive. D engines come in packages of three, and cost about \$5.00 per package. Rocket engines are perhaps the single most useful item sold in stores to a terrorist, since they can be used as is, or can be cannibalized for their explosive powder.

## 2.04 RIFLE/SHOTGUN POWDER

Rifle powder and shotgun powder are really the same from a practical standpoint. They are both nitrocellulose based propellants. They will be referred to as gunpowder in all future references. Gunpowder is made by the action of concentrated nitric and sulfuric acid upon cotton. This material is then dissolved by solvents and then reformed in the desired grain size. When dealing with gunpowder, the grain size is not nearly as important as that of black powder. Both large and small grained gunpowder burn fairly slowly compared to black powder when unconfined, but when it is confined, gunpowder burns both hotter and with more gaseous expansion, producing more pressure. Therefore, the grinding process that is often necessary for other propellants is not necessary for gunpowder. Gunpowder costs about \$9.00 per pound. Any idiot can buy it, since there are no restrictions on rifles or shotguns in the U.S.

\*\*\*\*\*

Revision by Vlad Tepes, 7-29-91

There are now ID checks in many states when purchasing powder at a retail outlet. Mail-orders aren't subject to such checks. Rifle powder and pyrodex may be purchased by mail order, but UPS charges will be high, due to DOT regulations on packaging.

\*\*\*\*\*

## 2.05 FLASH POWDER

Flash powder is a mixture of powdered zirconium metal and various oxidizers. It is extremely sensitive to heat or sparks, and should be treated with more care than black powder, with which it should NEVER be mixed. It is sold in small containers which must be mixed and shaken before use. It is very finely powdered, and is available in three speeds: fast, medium, and slow. The fast flash powder is the best for using in explosives or detonators.

It burns very rapidly, regardless of confinement or packing, with a hot white "flash", hence its name. It is fairly expensive, costing about \$11.00. It is sold in magic shops and theatre supply stores.

\*\*\*\* Revision by Vlad Tepes, 7-29-91

Flash powder is often made with aluminum and/or magnesium. Zirconium metal is the main ingredient in flash BULBS, but is too expensive to be used in most flash powder mixtures.

\*\*\*\*

## 2.06 AMMONIUM NITRATE

Ammonium nitrate is a high explosive material that is often used as a commercial "safety explosive". It is very stable, and is difficult to ignite with a match. It will only light if the glowing, red-hot part of a match is touching it. It is also difficult to detonate; (the phenomenon of detonation will be explained later) it requires a large shockwave to cause it to go high explosive. Commercially, it is sometimes mixed with a small amount of nitroglycerine to increase its sensitivity. Ammonium nitrate is used in the "Cold-Paks" or "Instant Cold", available in most drug stores. The "Cold Paks" consist of a bag of water, surrounded by a second plastic bag containing the ammonium nitrate. To get the ammonium nitrate, simply cut off the top of the outside bag, remove the plastic bag of water, and save the ammonium nitrate in a well sealed, airtight container, since it is rather hygroscopic, i.e. it tends to absorb water from the air. It is also the main ingredient in many fertilizers.

## 2.1 ACQUIRING CHEMICALS

The first section deals with getting chemicals legally. This section deals with "procuring" them. The best place to steal chemicals is a college. Many state schools have all of their chemicals out on the shelves in the labs, and more in their chemical stockrooms. Evening is the best time to enter lab buildings, as there are the least number of people in the buildings, and most of the labs will still be unlocked. One simply takes a bookbag, wears a dress shirt and jeans, and tries to resemble a college freshman. If anyone asks what such a person is doing, the thief can simply say that he is looking for the polymer chemistry lab, or some other chemistry-related department other than the one they are in. One can usually find out where the various labs and departments in a building are by calling the university. There are, of course other techniques for getting into labs after hours, such as placing a piece of cardboard in the latch of an unused door, such as a back exit. Then, all one needs to do is come back at a later hour. Also, before this is done, terrorists check for security systems. If one just walks into a lab, even if there is someone there, and walks out the back exit, and slip the cardboard in the latch before the door closes, the person in the lab will never know what happened. It is also a good idea to observe the building that one plans to rob at the time that one plans to rob it several days before the actual theft is done. This is advisable since the would-be thief should know when and if the campus security makes patrols through buildings. Of course, if none of these

methods are successful, there is always section 2.11, but as a rule, college campus security is pretty poor, and nobody suspects another person in the building of doing anything wrong, even if they are there at an odd hour.

## 2.11 TECHNIQUES FOR PICKING LOCKS

If it becomes necessary to pick a lock to enter a lab, the world's most effective lockpick is dynamite, followed by a sledgehammer. There are unfortunately, problems with noise and excess structural damage with these methods. The next best thing, however, is a set of army issue lockpicks.

These, unfortunately, are difficult to acquire. If the door to a lab is locked, but the deadbolt is not engaged, then there are other possibilities. The rule here is: if one can see the latch, one can open the door. There are several devices which facilitate freeing the latch from its hole in the wall. Dental tools, stiff wire ( 20 gauge ), specially bent aluminum from cans, thin pocket-knives, and credit cards are the tools of the trade. The way that all these tools and devices are uses is similar: pull, push, or otherwise move the latch out of its hole in the wall, and pull the door open. This is done by sliding whatever tool that you are using behind the latch, and pulling the latch out from the wall. To make an aluminum-can lockpick, terrorists can use an aluminum can and carefully cut off the can top and bottom. Cut off the cans' ragged ends. Then, cut the open-ended cylinder so that it can be flattened out into a single long rectangle. This should then be cut into inch wide strips. Fold the strips in 1/4 inch increments (1). One will have a long quadruple-thick 1/4 inch wide strip of aluminum. This should be folded into an L-shape, a J-shape, or a U-shape. This is done by folding. The pieces would look like this:

(1)

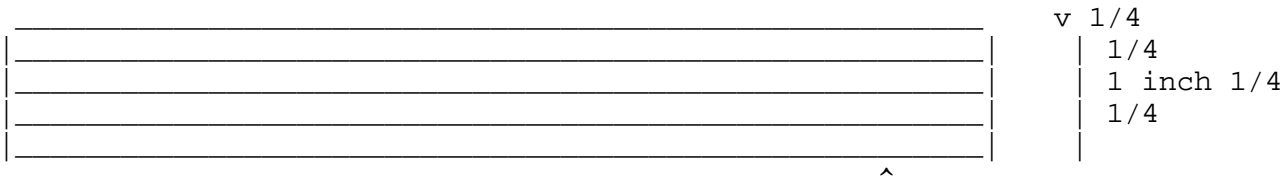

Fold along lines to make a single quadruple-thick piece of aluminum. This should then be folded to produce an L,J,or U shaped device that looks like this:

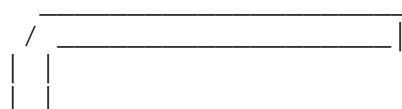
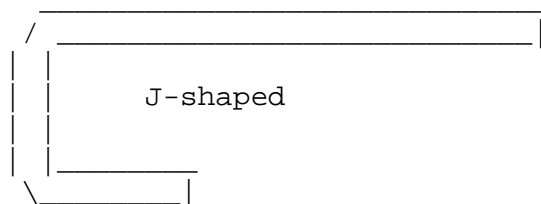
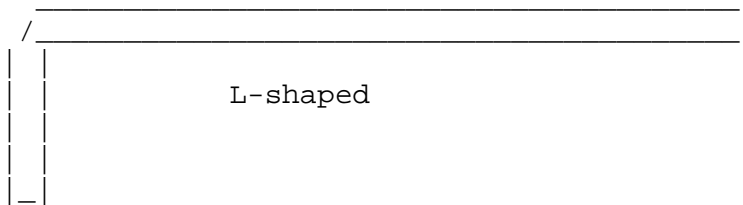

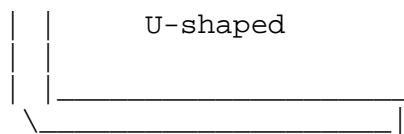

All of these devices should be used to hook the latch of a door and pull the latch out of its hole. The folds in the lockpicks will be between the door and the wall, and so the device will not unfold, if it is made properly.

Addendum 4/12/91

Another method of forced entry is to use an automobile jack to force the frame around the door out of shape, freeing the latch or exposing it to the above methods. This is possible because most door frames are designed with a slight amount of "give". Simply put the jack into position horizontally across the frame in the vicinity of the latch, and jack it out. If the frame is wood it may be possible to remove the jack after shutting the door, which will relock the door and leave few signs of forced entry.

## 2.2 LIST OF USEFUL HOUSEHOLD CHEMICALS AND THEIR AVAILABILITY

Anyone can get many chemicals from hardware stores, supermarkets, and drug stores to get the materials to make explosives or other dangerous compounds. A would-be terrorist would merely need a station wagon and some money to acquire many of the chemicals named here.

<u>Chemical</u>	<u>Used In</u>	<u>Available at</u>
alcohol, ethyl *	alcoholic beverages	liquor stores
ammonia +	solvents (95% min. for both) CLEAR household ammonia	hardware stores supermarkets/7-eleven
ammonium	instant-cold paks, fertilizers	drug stores, nitrate medical supply stores
nitrous oxide	pressurizing whip cream poppers (like CO2 ctgs.)	party supply stores Head shops, The Alley Belmont/Clark, Chgo
magnesium	firestarters	surplus/camping stores
lecithin	vitamins	pharmacies/drug stores
mineral oil	cooking, laxative	supermarket/drug stores
mercury @	mercury thermometers	supermarkets/hardware stores
sulfuric acid	uncharged car batteries	automotive stores
glycerine	?	pharmacies/drug stores
sulfur	gardening	gardening/hardware store
charcoal	charcoal grills	supermarkets/gardening stores
sodium nitrate	fertilizer	gardening store
cellulose (cotton)	first aid	drug/medical supply stores

strontium nitrate	road flares	surplus/auto stores,
fuel oil	kerosene stoves	surplus/camping stores,
bottled gas	propane stoves	surplus/camping stores,
potassium permanganate	water purification	purification plants
hexamine or methenamine	hexamine stoves (camping)	surplus/camping stores
nitric acid ^	cleaning printing plates	printing shops photography stores
Iodine	disinfectant (tinture)	Pharmacy, OSCO
sodium perchlorate	solidox pellets (VERY impure)	hardware stores for cutting torches

notes: \* ethyl alcohol is mixed with methyl alcohol when it is used as a solvent. Methyl alcohol is very poisonous. Solvent alcohol must be at least 95% ethyl alcohol if it is used to make mercury fulminate. Methyl alcohol may prevent mercury fulminate from forming.

+ Ammonia, when bought in stores comes in a variety of forms. The pine and cloudy ammonias should not be bought; only the clear ammonia should be used to make ammonium triiodide crystals.

@ Mercury thermometers are becoming a rarity, unfortunately. They may be hard to find in most stores as they have been superseded by alcohol and other less toxic fillings. Mercury is also used in mercury switches, which are available at electronics stores. Mercury is a hazardous substance, and should be kept in the thermometer or mercury switch until used. It gives off mercury vapors which will cause brain damage if inhaled. For this reason, it is a good idea not to spill mercury, and to always use it outdoors. Also, do not get it in an open cut; rubber gloves will help prevent this.

^ Nitric acid is very difficult to find nowadays. It is usually stolen by bomb makers, or made by the process described in a later section. A desired concentration for making explosives about 70%.

& The iodine sold in drug stores is usually not the pure crystalline form that is desired for producing ammonium triiodide crystals. To obtain the pure form, it must usually be acquired by a doctor's prescription, but this can be expensive. Once again, theft is the means that terrorists result to.

## 2.3 PREPARATION OF CHEMICALS

### 2.31 NITRIC ACID

There are several ways to make this most essential of all acids for explosives. One method by which it could be made will be presented. Once again, be reminded that these methods SHOULD NOT BE CARRIED OUT!!

#### Materials:

ÄÄÄÄÄÄÄÄÄÄ

sodium nitrate or  
potassium nitrate

distilled water

concentrated  
sulfuric acid

#### Equipment:

ÄÄÄÄÄÄÄÄÄÄ

adjustable heat source

retort

ice bath

stirring rod

collecting flask with stopper

- 1) Pour 32 milliliters of concentrated sulfuric acid into the retort.
- 2) Carefully weigh out 58 grams of sodium nitrate, or 68 grams of potassium nitrate. and add this to the acid slowly. If it all does not dissolve, carefully stir the solution with a glass rod until it does.
- 3) Place the open end of the retort into the collecting flask, and place the collecting flask in the ice bath.
- 4) Begin heating the retort, using low heat. Continue heating until liquid begins to come out of the end of the retort. The liquid that forms is nitric acid. Heat until the precipitate in the bottom of the retort is almost dry, or until no more nitric acid is forming. CAUTION: If the acid is heated too strongly, the nitric acid will decompose as soon as it is formed. This can result in the production of highly flammable and toxic gasses that may explode. It is a good idea to set the above apparatus up, and then get away from it.

Potassium nitrate could also be obtained from store-bought black powder, simply by dissolving black powder in boiling water and filtering out the sulfur and charcoal. To obtain 68 g of potassium nitrate, it would be necessary to dissolve about 90 g of black powder in about one litre of boiling water. Filter the dissolved solution through filter paper in a funnel into a jar until the liquid that pours through is clear. The charcoal and sulfur in black powder are insoluble in water, and so when the solution of water is allowed to evaporate, potassium nitrate will be left in the jar.

## 2.32 SULFURIC ACID

Sulfuric acid is far too difficult to make outside of a laboratory or industrial plant. However, it is readily available in an uncharged car battery. A person wishing to make sulfuric acid would simply remove the top of a car battery and pour the acid into a glass container. There would probably be pieces of lead from the battery in the acid which would have to be removed, either by boiling or filtration. The concentration of the sulfuric acid can also be increased by boiling it; very pure sulfuric acid pours slightly faster than clean motor oil.

## 2.33 AMMONIUM NITRATE

Ammonium nitrate is a very powerful but insensitive high-order explosive. It could be made very easily by pouring nitric acid into a large flask in an ice bath. Then, by simply pouring household ammonia into the flask and running away, ammonium nitrate would be formed. After the materials have stopped reacting, one would simply have to leave the solution in a warm place until all of the water and any unneutralized ammonia or acid have evaporated. There would be a fine powder formed, which would be ammonium nitrate. It must be kept in an airtight container, because of its tendency to pick up water from the air. The crystals formed in the above process would have to be heated VERY gently to drive off the remaining water.

### 3.0 EXPLOSIVE RECIPES

Once again, persons reading this material MUST NEVER ATTEMPT TO PRODUCE ANY OF THE EXPLOSIVES DESCRIBED HEREIN. IT IS ILLEGAL AND EXTREMELY DANGEROUS TO ATTEMPT TO DO SO. LOSS OF LIFE AND/OR LIMB COULD EASILY OCCUR AS A RESULT OF ATTEMPTING TO PRODUCE EXPLOSIVE MATERIALS.

These recipes are theoretically correct, meaning that an individual could conceivably produce the materials described. The methods here are usually scaled-down industrial procedures.

#### 3.01 EXPLOSIVE THEORY

An explosive is any material that, when ignited by heat or shock, undergoes rapid decomposition or oxidation. This process releases energy that is stored in the material in the form of heat and light, or by breaking down into gaseous compounds that occupy a much larger volume than the original piece of material. Because this expansion is very rapid, large volumes of air are displaced by the expanding gasses. This expansion occurs at a speed greater than the speed of sound, and so a sonic boom occurs. This explains the mechanics behind an explosion. Explosives occur in several forms: high-order explosives which detonate, low order explosives, which burn, and primers, which may do both.

High order explosives detonate. A detonation occurs only in a high order explosive. Detonations are usually incurred by a shockwave that passes through a block of the high explosive material. The shockwave breaks apart the molecular bonds between the atoms of the substance, at a rate approximately equal to the speed of sound traveling through that material. In a high explosive, the fuel and oxidizer are chemically bonded, and the shockwave breaks apart these bonds, and re-combines the two materials to produce mostly gasses. T.N.T., ammonium nitrate, and R.D.X. are examples of high order explosives.

Low order explosives do not detonate; they burn, or undergo oxidation. When heated, the fuel(s) and oxidizer(s) combine to produce heat, light, and gaseous products. Some low order materials burn at about the same speed under pressure as they do in the open, such as blackpowder. Others, such as gunpowder, which is correctly called nitrocellulose, burn much faster and hotter when they are in a confined space, such as the barrel of a firearm; they usually burn much slower than blackpowder when they are ignited in unpressurized conditions. Black powder, nitrocellulose, and flash powder are good examples of low order explosives.

Primers are peculiarities to the explosive field. Some of them, such as mercury fulminate, will function as a low or high order explosive. They are usually more sensitive to friction, heat, or shock, than the high or low explosives. Most primers perform like a high order explosive, except that they are much more sensitive. Still others merely burn, but when they are confined, they burn at a great rate and with a large expansion of gasses and a shockwave. Primers are usually used in a small amount to initiate, or cause to decompose, a high order explosive, as in an artillery shell. But, they are also frequently used to ignite a low order explosive; the gunpowder in a bullet is ignited by the detonation of its primer.

### 3.1 IMPACT EXPLOSIVES

Impact explosives are often used as primers. Of the ones discussed here, only mercury fulminate and nitroglycerine are real explosives; Ammonium triiodide crystals decompose upon impact, but they release little heat and no light. Impact explosives are always treated with the greatest care, and even the stupidest anarchist never stores them near any high or low explosives.

#### 3.11 AMMONIUM TRIIODIDE CRYSTALS

Ammonium triiodide crystals are foul-smelling purple colored crystals that decompose under the slightest amount of heat, friction, or shock, if they are made with the purest ammonia (ammonium hydroxide) and iodine. Such crystals are said to detonate when a fly lands on them, or when an ant walks across them. Household ammonia, however, has enough impurities, such as soaps and abrasive agents, so that the crystals will detonate when thrown, crushed, or heated. Upon detonation, a loud report is heard, and a cloud of purple iodine gas appears about the detonation site. Whatever the unfortunate surface that the crystal was detonated upon will usually be ruined, as some of the iodine in the crystal is thrown about in a solid form, and iodine is corrosive. It leaves nasty, ugly, permanent brownish-purple stains on whatever it contacts. Iodine gas is also bad news, since it can damage lungs, and it settles to the ground and stains things there also. Touching iodine leaves brown stains on the skin that last for about a week, unless they are immediately and vigorously washed off. While such a compound would have little use to a serious terrorist, a vandal could utilize them in damaging property. Or, a terrorist could throw several of them into a crowd as a distraction, an action which would possibly injure a few people, but frighten almost anyone, since a small crystal that not be seen when thrown produces a rather loud explosion.

Ammonium triiodide crystals could be produced in the following manner:

Materials	Equipment
iodine crystals	funnel and filter paper
clear ammonia (ammonium hydroxide, for the suicidal)	paper towels two throw-away glass jars

- 1) Place about two teaspoons of iodine into one of the glass jars. The jars must both be throw away because they will never be clean again.
- 2) Add enough ammonia to completely cover the iodine.
- 3) Place the funnel into the other jar, and put the filter paper in the funnel. The technique for putting filter paper in a funnel is taught in every basic chemistry lab class: fold the circular paper in half, so that a semi-circle is formed. Then, fold it in half again to form a triangle with one curved side. Pull one thickness of paper out to form a cone, and place the cone into the funnel.
- 4) After allowing the iodine to soak in the ammonia for a while, pour the solution into the paper in the funnel through the filter paper.
- 5) While the solution is being filtered, put more ammonia into the first jar to wash any remaining crystals into the funnel as soon as it drains.
- 6) Collect all the purplish crystals without touching the brown filter paper, and place them on the paper towels to dry for about an hour. Make sure that they are not too close to any lights or other sources of heat, as they could well detonate. While they are still wet, divide the wet material into about eight chunks.
- 7) After they dry, gently place the crystals onto a one square inch piece of duct tape. Cover it with a similar piece, and gently press the duct tape together around the crystal, making sure not to press the crystal itself. Finally, cut away most of the excess duct tape with a pair of scissors, and store the crystals in a cool dry safe place. They have a shelf life of about a week, and they should be stored in individual containers that can be thrown away, since they have a tendency to slowly decompose, a process which gives off iodine vapors, which will stain whatever they settle on. One possible way to increase their shelf life is to store them in airtight containers. To use them, simply throw them against any surface or place them where they will be stepped on or crushed.

## 3.12 MERCURY FULMINATE

Mercury fulminate is perhaps one of the oldest known initiating compounds. It can be detonated by either heat or shock, which would make it of infinite value to a terrorist. Even the action of dropping a crystal of the fulminate causes it to explode. A person making this material would probably use the following procedure:

MATERIALS  
ÄÄÄÄÄÄÄÄÄÄ

mercury (5 g)  
  
concentrated nitric  
acid (35 ml)  
  
ethyl alcohol (30 ml)  
  
distilled water

EQUIPMENT  
ÄÄÄÄÄÄÄÄÄÄ

glass stirring rod  
  
100 ml beaker (2)  
  
adjustable heat  
source  
  
blue litmus paper  
  
funnel and filter paper

- 1) In one beaker, mix 5 g of mercury with 35 ml of concentrated nitric acid, using the glass rod.
- 2) Slowly heat the mixture until the mercury is dissolved, which is when the solution turns green and boils.
- 3) Place 30 ml of ethyl alcohol into the second beaker, and slowly and carefully add all of the contents of the first beaker to it. Red and/or brown fumes should appear. These fumes are toxic and flammable.
- 4) After thirty to forty minutes, the fumes should turn white, indicating that the reaction is near completion. After ten more minutes, add 30 ml of the distilled water to the solution.
- 5) Carefully filter out the crystals of mercury fulminate from the liquid solution. Dispose of the solution in a safe place, as it is corrosive and toxic.
- 6) Wash the crystals several times in distilled water to remove as much excess acid as possible. Test the crystals with the litmus paper until they are neutral. This will be when the litmus paper stays blue when it touches the wet crystals
- 7) Allow the crystals to dry, and store them in a safe place, far away from any explosive or flammable material.

This procedure can also be done by volume, if the available mercury cannot be weighed. Simply use 10 volumes of nitric acid and 10 volumes of ethanol to every one volume of mercury.

## 3.13 NITROGLYCERINE

Nitroglycerine is one of the most sensitive explosives, if it is not the most sensitive. Although it is possible to make it safely, it is difficult. Many a young anarchist has been killed or seriously injured while trying to make the stuff. When Nobel's factories make it, many people were killed by the all- to-frequent factory explosions. Usually, as soon as it is made, it is converted into a safer substance, such as dynamite. An idiot who attempts to make nitroglycerine would use the following procedure:

MATERIAL ÄÄÄÄÄÄÄÄ	EQUIPMENT ÄÄÄÄÄÄÄÄÄÄ
distilled water	eye-dropper
table salt	100 ml beaker
sodium bicarbonate	200-300 ml beakers (2)
concentrated nitric acid (13 ml)	ice bath container ( a plastic bucket serves well )
concentrated sulfuric acid (39 ml)	centigrade thermometer
glycerine	blue litmus paper

- 1) Place 150 ml of distilled water into one of the 200-300 ml beakers.
- 2) In the other 200-300 ml beaker, place 150 ml of distilled water and about a spoonful of sodium bicarbonate, and stir them until the sodium bicarbonate dissolves. Do not put so much sodium bicarbonate in the water so that some remains undissolved.
- 3) Create an ice bath by half filling the ice bath container with ice, and adding table salt. This will cause the ice to melt, lowering the overall temperature.
- 4) Place the 100 ml beaker into the ice bath, and pour the 13 ml of concentrated nitric acid into the 100 ml beaker. Be sure that the beaker will not spill into the ice bath, and that the ice bath will not overflow into the beaker when more materials are added to it. Be sure to have a large enough ice bath container to add more ice. Bring the temperature of the acid down to about 20 degrees centigrade or less.

5) When the nitric acid is as cold as stated above, slowly and carefully add the 39 ml of concentrated sulfuric acid to the nitric acid. Mix the two acids together, and cool the mixed acids to 10 degrees centigrade. It is a good idea to start another ice bath to do this.

6) With the eyedropper, slowly put the glycerine into the mixed acids, one drop at a time. Hold the thermometer along the top of the mixture where the mixed acids and glycerine meet.

DO NOT ALLOW THE TEMPERATURE TO GET ABOVE 30 DEGREES CENTIGRADE; IF THE TEMPERATURE RISES ABOVE THIS TEMPERATURE, RUN LIKE HELL!!!

The glycerine will start to nitrate immediately, and the temperature will immediately begin to rise. Add glycerine until there is a thin layer of glycerine on top of the mixed acids. It is always safest to make any explosive in small quantities.

7) Stir the mixed acids and glycerine for the first ten minutes of nitration, adding ice and salt to the ice bath to keep the temperature of the solution in the 100 ml beaker well below 30 degrees centigrade. Usually, the nitroglycerine will form on the top of the mixed acid solution, and the concentrated sulfuric acid will absorb the water produced by the reaction.

8) When the reaction is over, and when the nitroglycerine is well below 30 degrees centigrade, slowly and carefully pour the solution of nitroglycerine and mixed acid into the distilled water in the beaker in step 1. The nitroglycerine should settle to the bottom of the beaker, and the water-acid solution on top can be poured off and disposed of. Drain as much of the acid-water solution as possible without disturbing the nitroglycerine.

9) Carefully remove the nitroglycerine with a clean eye-dropper, and place it into the beaker in step 2. The sodium bicarbonate solution will eliminate much of the acid, which will make the nitroglycerine more stable, and less likely to explode for no reason, which it can do. Test the nitroglycerine with the litmus paper until the litmus stays blue. Repeat this step if necessary, and use new sodium bicarbonate solutions as in step 2.

10) When the nitroglycerine is as acid-free as possible, store it in a clean container in a safe place. The best place to store nitroglycerine is far away from anything living, or from anything of any value. Nitroglycerine can explode for no apparent reason, even if it is stored in a secure cool place.

## 3.14 PICRATES

Although the procedure for the production of picric acid, or trinitrophenol has not yet been given, its salts are described first, since they are extremely sensitive, and detonate on impact. By mixing picric acid with metal hydroxides, such as sodium or potassium hydroxide, and evaporating the water, metal picrates can be formed. Simply obtain picric acid, or produce it, and mix it with a solution of (preferably) potassium hydroxide, of a mid range molarity. (about 6-9 M) This material, potassium picrate, is impact-sensitive, and can be used as an initiator for any type of high explosive.

## 3.2 LOW-ORDER EXPLOSIVES

There are many low-order explosives that can be purchased in gun stores and used in explosive devices. However, it is possible that a wise store owner would not sell these substances to a suspicious-looking individual. Such an individual would then be forced to resort to making his own low-order explosives.

## 3.21 BLACK POWDER

First made by the Chinese for use in fireworks, black powder was first used in weapons and explosives in the 12th century. It is very simple to make, but it is not very powerful or safe. Only about 50% of black powder is converted to hot gasses when it is burned; the other half is mostly very fine burned particles. Black powder has one major problem: it can be ignited by static electricity. This is very bad, and it means that the material must be made with wooden or clay tools. Anyway, a misguided individual could manufacture black powder at home with the following procedure:

## MATERIALS

ÄÄÄÄÄÄÄÄÄÄ

potassium  
nitrate (75 g)

or

sodium  
nitrate (75 g)

sulfur (10 g)

charcoal (15 g)

distilled water

## EQUIPMENT

ÄÄÄÄÄÄÄÄÄÄ

clay grinding bowl  
and clay grinder

or

wooden salad bowl  
and wooden spoon

plastic bags (3)

300-500 ml beaker (1)

coffee pot or heat source

- 1) Place a small amount of the potassium or sodium nitrate in the grinding bowl and grind it to a very fine powder. Do this to all of the potassium or sodium nitrate, and store the ground powder in one of the plastic bags.
- 2) Do the same thing to the sulfur and charcoal, storing each chemical in a separate plastic bag.
- 3) Place all of the finely ground potassium or sodium nitrate in the beaker, and add just enough boiling water to the chemical to get it all wet.
- 4) Add the contents of the other plastic bags to the wet potassium or sodium nitrate, and mix them well for several minutes. Do this until there is no more visible sulfur or charcoal, or until the mixture is universally black.
- 5) On a warm sunny day, put the beaker outside in the direct sunlight. Sunlight is really the best way to dry black powder, since it is never too hot, but it is hot enough to evaporate the water.
- 6) Scrape the black powder out of the beaker, and store it in a safe container. Plastic is really the safest container, followed by paper. Never store black powder in a plastic bag, since plastic bags are prone to generate static electricity.

### 3.22 NITROCELLULOSE

Nitrocellulose is usually called "gunpowder" or "guncotton". It is more stable than black powder, and it produces a much greater volume of hot gas. It also burns much faster than black powder when it is in a confined space. Finally, nitrocellulose is fairly easy to make, as outlined by the following procedure:

MATERIALS

ÄÄÄÄÄÄÄÄÄÄ

cotton (cellulose)

concentrated  
nitric acid

concentrated  
sulfuric acid

distilled water

EQUIPMENT

ÄÄÄÄÄÄÄÄÄÄ

two (2) 200-300 ml beakers

funnel and filter paper

blue litmus paper

- 1) Pour 10 cc of concentrated sulfuric acid into the beaker. Add to this 10  
cc of concentrated nitric acid.
- 2) Immediately add 0.5 gm of cotton, and allow it to soak for exactly 3  
minutes.
- 3) Remove the nitrocotton, and transfer it to a beaker of distilled water to  
wash it in.
- 4) Allow the material to dry, and then re-wash it.
- 5) After the cotton is neutral when tested with litmus paper, it is ready to  
be dried and stored.

\*\*\*\*

Addendum 4/12/91... true experience From andrew at cmu.edu (internet)

> I used to make nitrocellulose, though. It was not guncotton grade, because I  
>didn't have oleum (H<sub>2</sub>SO<sub>4</sub> with dissolved SO<sub>3</sub>); nevertheless it worked. At  
>first I got my H<sub>2</sub>SO<sub>4</sub> from a little shop in downtown Philadelphia, which sold  
>soda-acid fire extinguisher refills. Not only was the acid concentrated,  
>cheap and plentiful, it came with enough carbonate to clean up. I'd add KNO<sub>3</sub>  
>and a little water (OK, I'd add the acid to the water - but there was so  
>little water, what was added to what made little difference. It spattered  
>concentrated H<sub>2</sub>SO<sub>4</sub> either way). Later on, when I could purchase the acids, I  
>believe I used 3 parts H<sub>2</sub>SO<sub>4</sub> to 1 part HNO<sub>3</sub>. For cotton, I'd use cotton wool  
>or cotton cloth.

>  
>Runaway nitration was commonplace, but it is usually not so disasterous with  
>nitrocellulose as it is with nitroglycerine. For some reason, I tried washing  
>the cotton cloth in a solution of lye, and rinsing it well in distilled  
>water. I let the cloth dry and then nitrated it. (Did I read this somewhere?)  
>When that product was nitrated, I never got a runaway reaction. BTW, water  
>quenched the runaway reaction of cellulose.

>  
>The product was washed thoroughly and allowed to dry. It dissolved (or turned  
>into mush) in acetone. It dissolved in alcohol/ether.

>  
>Warnings:

>  
>All usual warnings regarding strong acids apply. H<sub>2</sub>SO<sub>4</sub> likes to spatter. When  
>it falls on the skin, it destroys tissue - often painfully. It dissolves all  
>manner of clothing. Nitric also destroys skin, turning it bright yellow in  
>the process. Nitric is an oxidant - it can start fires. Both agents will  
>happily blind you if you get them in your eyes. Other warnings also apply.  
>Not for the novice.

>  
> Nitrocellulose decomposes very slowly on storage. The decomposition is auto-  
>catalyzing, and can result in spontaneous explosion if the material is kept  
>confined over time. The process is much faster if the material is not washed  
>well enough. Nitrocellulose powders contain stabilizers such as diphenyl  
>amine or ethyl centralite. DO NOT ALLOW THESE TO COME INTO CONTACT WITH  
>NITRIC ACID!!!! A small amount of either substance will capture the small  
>amounts of nitrogen oxides that result from decomposition. They therefore  
>inhibit the autocatalysis. NC eventually will decompose in any case.

>  
>Again, this is inherently dangerous and illegal in certain areas. I got away  
>with it. You may kill yourself and others if you try it.

\*\*\*\*

Commercially produced Nitrocellulose is stabilized by:

1. Spinning it in a large centrifuge to remove the remaining acid, which is recycled.
2. Immersion in a large quantity of fresh water.
3. Boiling it in acidulated water and washing it thoroughly with fresh water.

If the NC is to be used as smokeless powder it is boiled in a soda solution, then rinsed in fresh water.

The purer the acid used (lower water content) the more complete the nitration will be, and the more powerful the nitrocellulose produced.

There are actually three forms of cellulose nitrate, only one of which is useful for pyrotechnic purposes. The mononitrate and dinitrate are not explosive, and are produced by incomplete nitration. If nitration is allowed to proceed to complete the explosive trinitrate is formed.

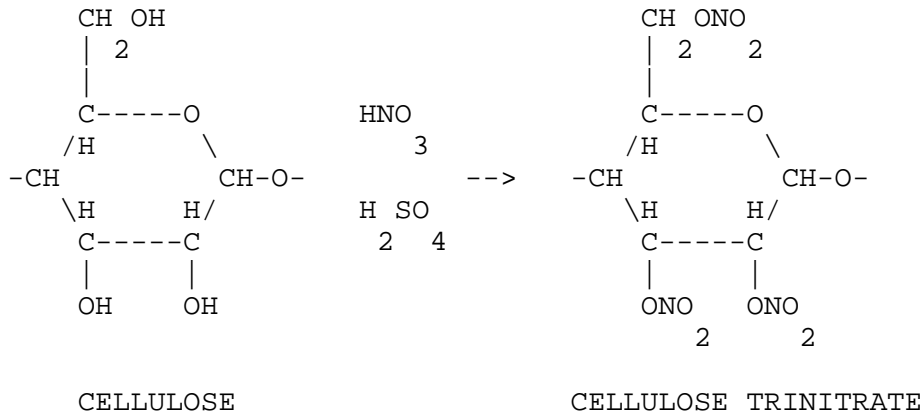

\*End Addendum

## 3.23 FUEL-OXODIZER MIXTURES

There are nearly an infinite number of fuel-oxodizer mixtures that can be produced by a misguided individual in his own home. Some are very effective and dangerous, while others are safer and less effective. A list of working fuel-oxodizer mixtures will be presented, but the exact measurements of each compound are debatable for maximum effectiveness. A rough estimate will be given of the percentages of each fuel and oxodizer:

oxodizer, % by weight	fuel, % by weight	speed #	notes
potassium chlorate 67%	sulfur 33%	5	friction/impact sensitive; unstable
potassium chlorate 50%	sugar 35% charcoal 15%	5	fairly slow burning; unstable
potassium chlorate 50%	sulfur 25% magnesium or aluminum dust 25%	8	extremely unstable!
potassium chlorate 67%	magnesium or aluminum dust 33%	8	unstable
sodium nitrate 65%	magnesium dust 30% sulfur 5%	?	unpredictable burn rate
potassium permanganate 60%	glycerine 40%	4	delay before ignition depends upon grain size
WARNING: IGNITES SPONTANEOUSLY WITH GLYCERINE!!!			
potassium permanganate 67%	sulfur 33%	5	unstable
potassium permanganate 60%	sulfur 20% magnesium or aluminum dust 20%	5	unstable
potassium permanganate 50%	sugar 50%	3	?
potassium nitrate 75%	charcoal 15% sulfur 10%	7	this is black powder!
potassium nitrate 60%	powdered iron or magnesium 40%	1	burns very hot

Oxidizer, % by weight	fuel, % by weight	speed #	notes
potassium chlorate 75%	phosphorus sesquisulfide 25%	8	used to make strike- anywhere matches
ammonium perchlorate 70%	aluminum dust 30% and small amount of iron oxide	6	solid fuel for space shuttle
potassium perchlorate 67% (sodium perchlorate)	magnesium or aluminum dust 33%	10	flash powder
potassium perchlorate 60% (sodium perchlorate)	magnesium or aluminum dust 20% sulfur 20%	8	alternate flash powder
barium nitrate 30% potassium perchlorate 30%	aluminum dust 30%	9	alternate flash powder
barium peroxide 90%	magnesium dust 5% aluminum dust 5%	10	alternate flash powder
potassium perchlorate 50%	sulfur 25% magnesium or aluminum dust 25%	8	slightly unstable
potassium chlorate 67% calcium carbonate 3%	red phosphorus 27% sulfur 3%	7	very unstable impact sensitive
potassium permanganate 50%	powdered sugar 25% aluminum or magnesium dust 25%	7	unstable; ignites if it gets wet!
potassium chlorate 75%	charcoal dust 15% sulfur 10%	6	unstable

NOTE: Mixtures that uses substitutions of sodium perchlorate for potassium perchlorate become moisture-absorbent and less stable.

The higher the speed number, the faster the fuel-oxidizer mixture burns AFTER ignition. Also, as a rule, the finer the powder, the faster the rate of burning.

As one can easily see, there is a wide variety of fuel-oxidizer mixtures that can be made at home. By altering the amounts of fuel and oxidizer(s), different burn rates can be achieved, but this also can change the sensitivity of the mixture.

### 3.24 PERCHLORATES

As a rule, any oxidizable material that is treated with perchloric acid will become a low order explosive. Metals, however, such as potassium or sodium, become excellent bases for flash-type powders. Some materials that can be perchlorated are cotton, paper, and sawdust. To produce potassium or sodium perchlorate, simply acquire the hydroxide of that metal, e.g. sodium or potassium hydroxide. It is a good idea to test the material to be treated with a very small amount of acid, since some of the materials tend to react explosively when contacted by the acid. Solutions of sodium or potassium hydroxide are ideal.

### 3.3 HIGH-ORDER EXPLOSIVES

High order explosives can be made in the home without too much difficulty. The main problem is acquiring the nitric acid to produce the high explosive. Most high explosives detonate because their molecular structure is made up of some fuel and usually three or more NO<sub>2</sub> ( nitrogen dioxide ) molecules. T.N.T., or Tri-Nitro-Toluene is an excellent example of such a material. When a shock wave passes through an molecule of T.N.T., the nitrogen dioxide bond is broken, and the oxygen combines with the fuel, all in a matter of microseconds. This accounts for the great power of nitrogen-based explosives. Remembering that these procedures are NEVER TO BE CARRIED OUT, several methods of manufacturing high-order explosives in the home are listed.

#### 3.31 R.D.X.

R.D.X., also called cyclonite, or composition C-1 (when mixed with plasticisers) is one of the most valuable of all military explosives. This is because it has more than 150% of the power of T.N.T., and is much easier to detonate. It should not be used alone, since it can be set off by a not-too severe shock. It is less sensitive than mercury fulminate, or nitroglycerine, but it is still too sensitive to be used alone. R.D.X. can be made by the surprisingly simple method outlined hereafter. It is much easier to make in the home than all other high explosives, with the possible exception of ammonium nitrate.

MATERIALS  
ÄÄÄÄÄÄÄÄÄÄ

EQUIPMENT  
ÄÄÄÄÄÄÄÄÄÄ

hexamine  
or  
methenamine  
fuel tablets (50 g)  
  
concentrated  
nitric acid (550 ml)  
  
distilled water  
  
table salt  
  
ice  
  
ammonium nitrate

500 ml beaker  
  
glass stirring rod  
  
funnel and filter paper  
  
ice bath container  
(plastic bucket)  
  
centigrade thermometer  
  
blue litmus paper

- 1) Place the beaker in the ice bath, (see section 3.13, steps 3-4) and carefully pour 550 ml of concentrated nitric acid into the beaker.
- 2) When the acid has cooled to below 20 degrees centigrade, add small amounts of the crushed fuel tablets to the beaker. The temperature will rise, and it must be kept below 30 degrees centigrade, or dire consequences could result. Stir the mixture.
- 3) Drop the temperature below zero degrees centigrade, either by adding more ice and salt to the old ice bath, or by creating a new ice bath. Or, ammonium nitrate could be added to the old ice bath, since it becomes cold when it is put in water. Continue stirring the mixture, keeping the temperature below zero degrees centigrade for at least twenty minutes
- 4) Pour the mixture into a litre of crushed ice. Shake and stir the mixture, and allow it to melt. Once it has melted, filter out the crystals, and dispose of the corrosive liquid.
- 5) Place the crystals into one half a litre of boiling distilled water. Filter the crystals, and test them with the blue litmus paper. Repeat steps 4 and 5 until the litmus paper remains blue. This will make the crystals more stable and safe.
- 6) Store the crystals wet until ready for use. Allow them to dry completely using them. R.D.X. is not stable enough to use alone as an explosive.
- 7) Composition C-1 can be made by mixing 88.3% R.D.X. (by weight) with 11.1% mineral oil, and 0.6% lecithin. Knead these material together in a plastic bag. This is a good way to desensitize the explosive.

- 8) H.M.X. is a mixture of T.N.T. and R.D.X.; the ratio is 50/50, by weight. it is not as sensitive, and is almost as powerful as straight R.D.X.
- 9) By adding ammonium nitrate to the crystals of R.D.X. after step 5, it should be possible to desensitize the R.D.X. and increase its power, since ammonium nitrate is very insensitive and powerful. Sodium or potassium nitrate could also be added; a small quantity is sufficient to stabilize the R.D.X.
- 10) R.D.X. detonates at a rate of 8550 meters/second when it is compressed to a density of 1.55 g/cubic cm.

### 3.32 AMMONIUM NITRATE

Ammonium nitrate could be made by a terrorist according to the hap-hazard method in section 2.33, or it could be stolen from a construction site, since it is usually used in blasting, because it is very stable and insensitive to shock and heat. A terrorist could also buy several Instant Cold-Paks from a drug store or medical supply store. The major disadvantage with ammonium nitrate, from a terrorist's point of view, would be detonating it. A rather powerful priming charge must be used, and usually with a booster charge. The diagram below will explain.

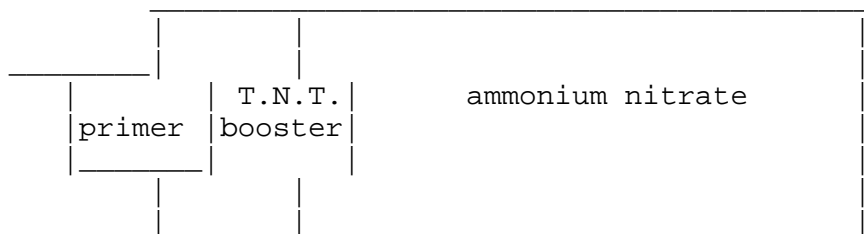

The primer explodes, detonating the T.N.T., which detonates, sending a tremendous shockwave through the ammonium nitrate, detonating it.

### 3.33 ANFOS

ANFO is an acronym for Ammonium Nitrate - Fuel Oil Solution. An ANFO solves the only other major problem with ammonium nitrate: its tendency to pick up water vapor from the air. This results in the explosive failing to detonate when such an attempt is made. This is rectified by mixing 94% (by weight) ammonium nitrate with 6% fuel oil, or kerosene. The kerosene keeps the ammonium nitrate from absorbing moisture from the air. An ANFO also requires a large shockwave to set it off.

\* Addendum From hayes.ims.alaska.edu (internet)

>

> Lately there has been a lot said about various ANFO mixtures. These are  
> mixtures of Ammonium Nitrate with Fuel Oil. This forms a reasonably powerful  
> commercial explosive, with its primary benefit being the fact that it is  
> cheap. Bulk ANFO should run somewhere around 9-12 cents the pound. This is  
> dirt cheap compared to 40% nitro gel dynamites at 1 to 2 dollars the pound.  
> To keep the cost down, it is frequently mixed at the borehole by a bulk  
> truck, which has a pneumatic delivery hopper of AN prills (that's pellets to  
> most of the world) and a tank of fuel oil. It is strongly recommended that a  
> dye of some sort, preferably red be added to the fuel oil to make it easier  
> to distinguish treated AN explosive from untreated oxidizer.

>

> ANFO is not without its problems. To begin with, it is not that sensitive  
> to detonation. Number eight caps are not reliable when used with ANFO.  
> Booster charges must be used to avoid dud blast holes. Common boosters  
> include sticks of various dynamites, small pours of water gel explosives,  
> Dupont's Detaprime cast boosters, and Atlas's power primer cast explosive.  
> The need to use boosters raises the cost. Secondly, ANFO is very water  
> susceptible. It dissolves in it, or absorbs it from the atmosphere, and  
> becomes quite worthless real quick. It must be protected from water with  
> borehole liners, and still must be shot real quick. Third, ANFO has a low  
> density, somewhere around .85. This means ANFO sacks float, which is no  
> good, and additionally, the low density means the power is somewhat low.  
> Generally, the more weight of explosive one can place in a hole, the more  
> effective. ANFO blown into the hole with a pneumatic system fractures as it  
> is placed, raising the density to about .9 or .92. The delivery system adds  
> to the cost, and must be anti static in nature. Aluminum is added to some  
> commercial, cartridge packaged ANFOs to raise the density---this also raises  
> power considerably, and a few of these mixtures are reliably cap sensitive.

>

> Now then, for formulations. An earlier article mentioned 2.5 kilos of  
> ammonium nitrate, and I believe 5 to 6 liters of diesel. This mixture is  
> extremely over fueled, and I'd be surprised if it worked. Dupont recommends  
> a AN to FO ratio of 93% AN to 7% FO by weight. Hardly any oil at all. More  
> oil makes the mixture less explosive by absorbing detonation energy, and  
> excess fuel makes detonation byproducts health hazards as the mixture is  
> oxygen poor. Note that commercial fertilizer products do not work as well as  
> the porous AN prills Dupont sells, because fertilizers are coated with  
> various materials meant to seal them from moisture, which keep the oil from  
> being absorbed.

> Another problem with ANFO: for reliable detonation, it needs confinement,  
>either from a casing, borehole, etc, or from the mass of the charge. Thus,  
>a pile of the stuff with a booster in it is likely to scatter and burn rather  
>than explode when the booster is shot. In boreholes, or reasonable strong  
>casings (cardboard, or heavy plastic film sacks) the stuff detonated quite  
>well. So will big piles. Thats how the explosive potential was discovered:  
>a small oil freighter rammed a bulk chemical ship. Over several hours the  
>cargoes intermixed to some degree, and reached critical mass. Real big  
>bang. A useful way to obtain the containment needed is to replace the fuel  
>oil with a wax fuel. Mix the AN with just enough melted wax to form a  
>cohesive mixture, mold into shape. The wax fuels, and retains the mixture.  
>This is what the US military uses as a man placed cratering charge. The  
>military literature states this can be set off by a blasting cap, but it  
>is important to remember the military blasting caps are considerable more  
>powerful than commercial ones. The military rightly insists on reliability,  
>and thus a strong cap (maybe 70-80 percent stronger than commercial). They  
>also tend to go overboard when calculating demolition charges...., but then  
>hey, who doesn't....

>  
> Two manuals of interest: Duponts "Blaster's Handbook", a \$20 manual  
>mainly useful for rock and seismographic operations. Atlas's "Powder Manual"  
>or "Manual of Rock Blasting" (I forget the title, its in the office). This  
>is a \$60 book, well worth the cash, dealing with the above two topics, plus  
>demolitions, and non-quarry blasting.

>  
> Incidentally, combining fuel oil and ammonium nitrate constitutes the  
>manufacture of a high explosive, and requires a federal permit to manufacture  
>and store. Even the mines that mix it on site require the permit to  
>manufacture. Those who don't manufacture only need permits to store. Those  
>who don't store need no permits, which includes most of us: anyone, at least  
>in the US may purchase explosives, provided they are 21 or older, and have no  
>criminal record. Note they ought to be used immediately, because you do need  
>a liscence to store. Note also that commercial explosives contain quantities  
>of tracing agents, which make it real easy for the FBI to trace the explosion  
>to the purchaser, so please, nobody blow up any banks, orphanages, or old  
>folks homes, okay.

>  
> Dean Syta, Civil Engineer at large.

\*End Addendum

## 3.34 T.N.T.

T.N.T., or Tri-Nitro-Toluene, is perhaps the second oldest known high explosive. Dynamite, of course, was the first. It is certainly the best known high explosive, since it has been popularized by early morning cartoons. It is the standard for comparing other explosives to, since it is the most well known. In industry, a T.N.T. is made by a three step nitration process that is designed to conserve the nitric and sulfuric acids which are used to make the product. A terrorist, however, would probably opt for the less economical one step method. The one step process is performed by treating toluene with very strong (fuming) sulfuric acid. Then, the sulfated toluene is treated with very strong (fuming) nitric acid in an ice bath. Cold water is added the solution, and it is filtered.

## 3.35 POTASSIUM CHLORATE

Potassium chlorate itself cannot be made in the home, but it can be obtained from labs. If potassium chlorate is mixed with a small amount of vaseline, or other petroleum jelly, and a shockwave is passed through it, the material will detonate with slightly more power than black powder. It must, however, be confined to detonate it in this manner. The procedure for making such an explosive is outlined below:

## MATERIALS

ÄÄÄÄÄÄÄÄÄÄ

potassium chlorate  
(9 parts, by volume)

petroleum jelly  
(vaseline)  
(1 part, by volume)

## EQUIPMENT

ÄÄÄÄÄÄÄÄÄÄ

zip-lock plastic bag

clay grinding bowl  
or  
wooden bowl and wooden spoon

- 1) Grind the potassium chlorate in the grinding bowl carefully and slowly, until the potassium chlorate is a very fine powder. The finer that it is powdered, the faster (better) it will detonate.
- 2) Place the powder into the plastic bag. Put the petroleum jelly into the plastic bag, getting as little on the sides of the bag as possible, i.e. put the vaseline on the potassium chlorate powder.
- 3) Close the bag, and kneed the materials together until none of the potassium chlorate is dry powder that does not stick to the main glob. If necessary, add a bit more petroleum jelly to the bag.
- 4) The material must me used within 24 hours, or the mixture will react to greatly reduce the effectiveness of the explosive. This reaction, however, is harmless, and releases no heat or dangerous products.

## 3.36 DYNAMITE

The name dynamite comes from the Greek word "dynamis", meaning power. Dynamite was invented by Nobel shortly after he made nitroglycerine. It was made because nitroglycerine was so dangerously sensitive to shock. A misguided individual with some sanity would, after making nitroglycerine (an insane act) would immediately convert it to dynamite. This can be done by adding various materials to the nitroglycerine, such as sawdust. The sawdust holds a large weight of nitroglycerine per volume. Other materials, such as ammonium nitrate could be added, and they would tend to desensitize the explosive, and increase the power. But even these nitroglycerine compounds are not really safe.

## 3.37 NITROSTARCH EXPLOSIVES

Nitrostarch explosives are simple to make, and are fairly powerful. All that need be done is treat various starches with a mixture of concentrated nitric and sulfuric acids. 10 ml of concentrated sulfuric acid is added to 10 ml of concentrated nitric acid. To this mixture is added 0.5 grams of starch. Cold water is added, and the apparently unchanged nitrostarch is filtered out. Nitrostarch explosives are of slightly lower power than T.N.T., but they are more readily detonated.

## 3.38 PICRIC ACID

Picric acid, also known as Tri-Nitro-Phenol, or T.N.P., is a military explosive that is most often used as a booster charge to set off another less sensitive explosive, such as T.N.T. It another explosive that is fairly simple to make, assuming that one can acquire the concentrated sulfuric and nitric acids. Its procedure for manufacture is given in many college chemistry lab manuals, and is easy to follow. The main problem with picric acid is its tendency to form dangerously sensitive and unstable picrate salts, such as potassium picrate. For this reason, it is usually made into a safer form, such as ammonium picrate, also called explosive D. A social deviant would probably use a formula similar to the one presented here to make picric acid.

## MATERIALS

ÄÄÄÄÄÄÄÄÄÄ

phenol (9.5 g)

concentrated  
sulfuric acid (12.5 ml)concentrated nitric  
acid (38 ml)

distilled water

## EQUIPMENT

ÄÄÄÄÄÄÄÄÄÄ

500 ml flask

adjustable heat source

1000 ml beaker  
or other container  
suitable for boiling infilter paper  
and funnel

glass stirring rod

- 1) Place 9.5 grams of phenol into the 500 ml flask, and carefully add 12.5 ml of concentrated sulfuric acid and stir the mixture.
- 2) Put 400 ml of tap water into the 1000 ml beaker or boiling container and bring the water to a gentle boil.
- 3) After warming the 500 ml flask under hot tap water, place it in the boiling water, and continue to stir the mixture of phenol and acid for about thirty minutes. After thirty minutes, take the flask out, and allow it to cool for about five minutes.
- 4) Pour out the boiling water used above, and after allowing the container to cool, use it to create an ice bath, similar to the one used in section 3.13, steps 3-4. Place the 500 ml flask with the mixed acid and phenol in the ice bath. Add 38 ml of concentrated nitric acid in small amounts, stirring the mixture constantly. A vigorous but "harmless" reaction should occur. When the mixture stops reacting vigorously, take the flask out of the ice bath.
- 5) Warm the ice bath container, if it is glass, and then begin boiling more tap water. Place the flask containing the mixture in the boiling water, and heat it in the boiling water for 1.5 to 2 hours.
- 6) Add 100 ml of cold distilled water to the solution, and chill it in an ice bath until it is cold.
- 7) Filter out the yellowish-white picric acid crystals by pouring the solution through the filter paper in the funnel. Collect the liquid and dispose of it in a safe place, since it is corrosive.
- 8) Wash out the 500 ml flask with distilled water, and put the contents of the filter paper in the flask. Add 300 ml of water, and shake vigorously.
- 9) Re-filter the crystals, and allow them to dry.
- 10) Store the crystals in a safe place in a glass container, since they will react with metal containers to produce picrates that could explode spontaneously.

### 3.39 AMMONIUM PICRATE

Ammonium picrate, also called Explosive D, is another safety explosive. It requires a substantial shock to cause it to detonate, slightly less than that required to detonate ammonium nitrate. It is much safer than picric acid, since it has little tendency to form hazardous unstable salts when placed in metal containers. It is simple to make from picric acid and clear household ammonia. All that need be done is put the picric acid crystals into a glass container and dissolve them in a great quantity of hot water. Add clear household ammonia in excess, and allow the excess ammonia to evaporate. The powder remaining should be ammonium picrate.

### 3.40 NITROGEN TRICHLORIDE

Nitrogen trichloride, also known as chloride of azode, is an oily yellow liquid. It explodes violently when it is heated above 60 degrees celsius, or when it comes in contact with an open flame or spark. It is fairly simple to produce.

- 1) In a beaker, dissolve about 5 teaspoons of ammonium nitrate in water. Do not put so much ammonium nitrate into the solution that some of it remains undissolved in the bottom of the beaker.
- 2) Collect a quantity of chlorine gas in a second beaker by mixing hydrochloric acid with potassium permanganate in a large flask with a stopper and glass pipe.
- 3) Place the beaker containing the chlorine gas upside down on top of the beaker containing the ammonium nitrate solution, and tape the beakers together. Gently heat the bottom beaker. When this is done, oily yellow droplets will begin to form on the surface of the solution, and sink down to the bottom. At this time, remove the heat source immediately.

Alternately, the chlorine can be bubbled through the ammonium nitrate solution, rather than collecting the gas in a beaker, but this requires timing and a stand to hold the beaker and test tube.

The chlorine gas can also be mixed with anhydrous ammonia gas, by gently heating a flask filled with clear household ammonia. Place the glass tubes from the chlorine-generating flask and the tube from the ammonia-generating flask in another flask that contains water.

- 4) Collect the yellow droplets with an eyedropper, and use them immediately, since nitrogen trichloride decomposes in 24 hours.

### 3.41 LEAD AZIDE

Lead Azide is a material that is often used as a booster charge for other explosive, but it does well enough on its own as a fairly sensitive explosive. It does not detonate too easily by percussion or impact, but it is easily detonated by heat from an igniter wire, or a blasting cap. It is simple to produce, assuming that the necessary chemicals can be procured.

By dissolving sodium azide and lead acetate in water in separate beakers, the two materials are put into an aqueous state. Mix the two beakers together, and apply a gentle heat. Add an excess of the lead acetate solution, until no reaction occurs, and the precipitate on the bottom of the beaker stops forming.

Filter off the solution, and wash the precipitate in hot water. The precipitate is lead azide, and it must be stored wet for safety. If lead acetate cannot be found, simply acquire acetic acid, and put lead metal in it. Black powder bullets work well for this purpose.

### 3.5 OTHER "EXPLOSIVES"

The remaining section covers the other types of materials that can be used to destroy property by fire. Although none of the materials presented here are explosives, they still produce explosive-style results.

#### 3.51 THERMITE

Thermite is a fuel-oxidizer mixture that is used to generate tremendous amounts of heat. It was not presented in section 3.23 because it does not react nearly as readily. It is a mixture of iron oxide and aluminum, both finely powdered. When it is ignited, the aluminum burns, and extracts the oxygen from the iron oxide. This is really two very exothermic reactions that produce a combined temperature of about 2200 degrees C. This is half the heat produced by an atomic weapon. It is difficult to ignite, however, but when it is ignited, it is one of the most effective firestarters around.

#### MATERIALS

ÄÄÄÄÄÄÄÄÄÄ

powdered aluminum (10 g)

powdered iron oxide (10 g)

- 1) There is no special procedure or equipment required to make thermit. Simply mix the two powders together, and try to make the mixture as homogenous as possible. The ratio of iron oxide to aluminum is 50% / 50% by weight, and be made in greater or lesser amounts.

2) Ignition of thermite can be accomplished by adding a small amount of potassium chlorate to the thermite, and pouring a few drops of sulfuric acid on it. This method and others will be discussed later in section 4.33. The other method of igniting thermite is with a magnesium strip. Finally, by using common sparkler-type fireworks placed in the thermit, the mixture can be ignited.

### 3.52 MOLOTOV COCKTAILS

First used by Russians against German tanks, the Molotov cocktail is now exclusively used by terrorists worldwide. They are extremely simple to make, and can produce devastating results. By taking any highly flammable material, such as gasoline, diesel fuel, kerosene, ethyl or methyl alcohol, lighter fluid, turpentine, or any mixture of the above, and putting it into a large glass bottle, anyone can make an effective firebomb. After putting the flammable liquid in the bottle, simply put a piece of cloth that is soaked in the liquid in the top of the bottle so that it fits tightly.

Then, wrap some of the cloth around the neck and tie it, but be sure to leave a few inches of loose cloth to light. Light the exposed cloth, and throw the bottle. If the burning cloth does not go out, and if the bottle breaks on impact, the contents of the bottle will spatter over a large area near the site of impact, and burst into flame.

Flammable mixtures such as kerosene and motor oil should be mixed with a more volatile and flammable liquid, such as gasoline, to insure ignition. A mixture such as tar or grease and gasoline will stick to the surface that it strikes, and burn hotter, and be more difficult to extinguish. A mixture such as this must be shaken well before it is lit and thrown

### 3.53 CHEMICAL FIRE BOTTLE

The chemical fire bottle is really an advanced molotov cocktail. Rather than using the burning cloth to ignite the flammable liquid, which has at best a fair chance of igniting the liquid, the chemical fire bottle utilizes the very hot and violent reaction between sulfuric acid and potassium chlorate. When the container breaks, the sulfuric acid in the mixture of gasoline sprays onto the paper soaked in potassium chlorate and sugar. The paper, when struck by the acid, instantly bursts into a white flame, igniting the gasoline. The chance of failure to ignite the gasoline is less than 2%, and can be reduced to 0%, if there is enough potassium chlorate and sugar to spare.

MATERIALS  
ÄÄÄÄÄÄÄÄÄÄ

EQUIPMENT  
ÄÄÄÄÄÄÄÄÄÄ

potassium chlorate  
(2 teaspoons)

glass bottle  
(12 oz.)

sugar (2 teaspoons)  
with plastic inside

cap for bottle, w/plastic inside

conc. sulfuric acid (4 oz.)

cooking pan with raised edges

gasoline (8 oz.)

paper towels

glass or plastic cup and spoon

- 1) Test the cap of the bottle with a few drops of sulfuric acid to make sure that the acid will not eat away the bottle cap during storage. If the acid eats through it in 24 hours, a new top must be found and tested, until a cap that the acid does not eat through is found. A glass top is excellent.
- 2) Carefully pour 8 oz. of gasoline into the glass bottle.
- 3) Carefully pour 4 oz. of concentrated sulfuric acid into the glass bottle. Wipe up any spills of acid on the sides of the bottle, and screw the cap on the bottle. Wash the bottle's outside with plenty of water. Set it aside to dry.
- 4) Put about two teaspoons of potassium chlorate and about two teaspoons of sugar into the glass or plastic cup. Add about 1/2 cup of boiling water, or enough to dissolve all of the potassium chlorate and sugar.
- 5) Place a sheet of paper towel in the cooking pan with raised edges. Fold the paper towel in half, and pour the solution of dissolved potassium chlorate and sugar on it until it is thoroughly wet. Allow the towel to dry.
- 6) When it is dry, put some glue on the outside of the glass bottle containing the gasoline and sulfuric acid mixture. Wrap the paper towel around the bottle, making sure that it sticks to it in all places. Store the bottle in a place where it will not be broken or tipped over.
- 7) When finished, the solution in the bottle should appear as two distinct liquids, a dark brownish-red solution on the bottom, and a clear solution on top. The two solutions will not mix. To use the chemical fire bottle, simply throw it at any hard surface.
- 8) NEVER OPEN THE BOTTLE, SINCE SOME SULFURIC ACID MIGHT BE ON THE CAP, WHICH COULD TRICKLE DOWN THE SIDE OF THE BOTTLE AND IGNITE THE POTASSIUM CHLORATE, CAUSING A FIRE AND/OR EXPLOSION.
- 9) To test the device, tear a small piece of the paper towel off the bottle, and put a few drops of sulfuric acid on it. The paper towel should immediately burst into a white flame.

### 3.54 BOTTLED GAS EXPLOSIVES

Bottled gas, such as butane for refilling lighters, propane for propane stoves or for bunsen burners, can be used to produce a powerful explosion. To make such a device, all that a simple-minded anarchist would have to do would be to take his container of bottled gas and place it above a can of Sterno or other gelatinized fuel, light the fuel and run. Depending on the fuel used, and on the thickness of the fuel container, the liquid gas will boil and expand to the point of bursting the container in about five minutes.

In theory, the gas would immediately be ignited by the burning gelatinized fuel, producing a large fireball and explosion. Unfortunately, the bursting of the bottled gas container often puts out the fuel, thus preventing the expanding gas from igniting. By using a metal bucket half filled with gasoline, however, the chances of ignition are better, since the gasoline is less likely to be extinguished. Placing the canister of bottled gas on a bed of burning charcoal soaked in gasoline would probably be the most effective way of securing ignition of the expanding gas, since although the bursting of the gas container may blow out the flame of the gasoline, the burning charcoal should immediately re-ignite it. Nitrous oxide, hydrogen, propane, acetylene, or any other flammable gas will do nicely.

Addendum 4/12/91:

During the recent gulf war, fuel/air bombs were touted as being second only to nuclear weapons in their devastating effects. These are basically similar to the above devices, except that an explosive charge is used to rupture the fuel container and disperse it over a wide area. a second charge is used to detonate the fuel. The reaction is said to produce a massive shockwave and to burn all the oxygen in a large area, causing suffocation.

Another benefit of a fuel-air explosive is that the gas will seep into fortified bunkers and other partially-sealed spaces, so a large bomb placed in a building would result in the destruction of the majority of surrounding rooms, rendering it structurally unsound.

\*End addendum

## 4.0 USING EXPLOSIVES

Once a terrorist has made his explosives, the next logical step is to apply them. Explosives have a wide range of uses, from harassment, to vandalism, to murder. NONE OF THE IDEAS PRESENTED HERE ARE EVER TO BE CARRIED OUT, EITHER IN PART OR IN FULL! DOING SO CAN LEAD TO PROSECUTION, FINES, AND IMPRISONMENT! The first step that a person that would use explosive would take would be to determine how big an explosive device would be needed to do whatever had to be done. Then, he would have to decide what to make his bomb with. He would also have to decide on how he wanted to detonate the device, and determine where the best placement for it would be. Then, it would be necessary to see if the device could be put where he wanted it without it being discovered or moved. Finally, he would actually have to sit down and build his explosive device. These are some of the topics covered in the next section.

### 4.1 SAFETY

There is no such thing as a "safe" explosive device. One can only speak in terms of relative safety, or less unsafe.

### 4.2 IGNITION DEVICES

There are many ways to ignite explosive devices. There is the classic "light the fuse, throw the bomb, and run" approach, and there are sensitive mercury switches, and many things in between. Generally, electrical detonation systems are safer than fuses, but there are times when fuses are more appropriate than electrical systems; it is difficult to carry an electrical detonation system into a stadium, for instance, without being caught. A device with a fuse or impact detonating fuse would be easier to hide.

#### 4.21 FUSE IGNITION

The oldest form of explosive ignition, fuses are perhaps the favorite type of simple ignition system. By simply placing a piece of waterproof fuse in a device, one can have almost guaranteed ignition. Modern waterproof fuse is extremely reliable, burning at a rate of about 2.5 seconds to the inch. It is available as model rocketry fuse in most hobby shops, and costs about \$3.00 for a nine-foot length. Fuse is a popular ignition system for pipe bombers because of its simplicity. All that need be done is light it with a match or lighter. Of course, if the Army had fuses like this, then the grenade, which uses fuse ignition, would be very impractical. If a grenade ignition system can be acquired, by all means, it is the most effective. But, since such things do not just float around, the next best thing is to prepare a fuse system which does not require the use of a match or lighter, but still retains its simplicity. One such method is described below:

## MATERIALS

---

strike-on-cover type matches

electrical tape or duct tape

waterproof fuse

1) To determine the burn rate of a particular type of fuse, simply measure a 6 inch or longer piece of fuse and ignite it. With a stopwatch, press the start button the at the instant when the fuse lights, and stop the watch when the fuse reaches its end. Divide the time of burn by the length of fuse, and you have the burn rate of the fuse, in seconds per inch. This will be shown below:

Suppose an eight inch piece of fuse is burned, and its complete time of combustion is 20 seconds.

$$\begin{array}{l} 20 \text{ seconds} \\ \hline 8 \text{ inches} \end{array} = 2.5 \text{ seconds per inch.}$$

If a delay of 10 seconds was desired with this fuse, divide the desired time by the number of seconds per inch:

$$\begin{array}{l} 10 \text{ seconds} \\ \hline 2.5 \text{ seconds / inch} \end{array} = 4 \text{ inches}$$

NOTE: THE LENGTH OF FUSE HERE MEANS LENGTH OF FUSE TO THE POWDER. SOME FUSE, AT LEAST AN INCH, SHOULD BE INSIDE THE DEVICE. ALWAYS ADD THIS EXTRA INCH, AND PUT THIS EXTRA INCH AN INCH INTO THE DEVICE!!!

2) After deciding how long a delay is desired before the explosive device is to go off, add about 1/2 an inch to the premeasured amount of fuse, and cut it off.

3) Carefully remove the cardboard matches from the paper match case. Do not pull off individual matches; keep all the matches attached to the cardboard base. Take one of the cardboard match sections, and leave the other one to make a second igniter.

4) Wrap the matches around the end of the fuse, with the heads of the matches touching the very end of the fuse. Tape them there securely, making sure not to put tape over the match heads. Make sure they are very secure by pulling on them at the base of the assembly. They should not be able to move.

- 5) Wrap the cover of the matches around the matches attached to the fuse, making sure that the striker paper is below the match heads and the striker faces the match heads. Tape the paper so that is fairly tight around the matches. Do not tape the cover of the striker to the fuse or to the matches. Leave enough of the match book to pull on for ignition.

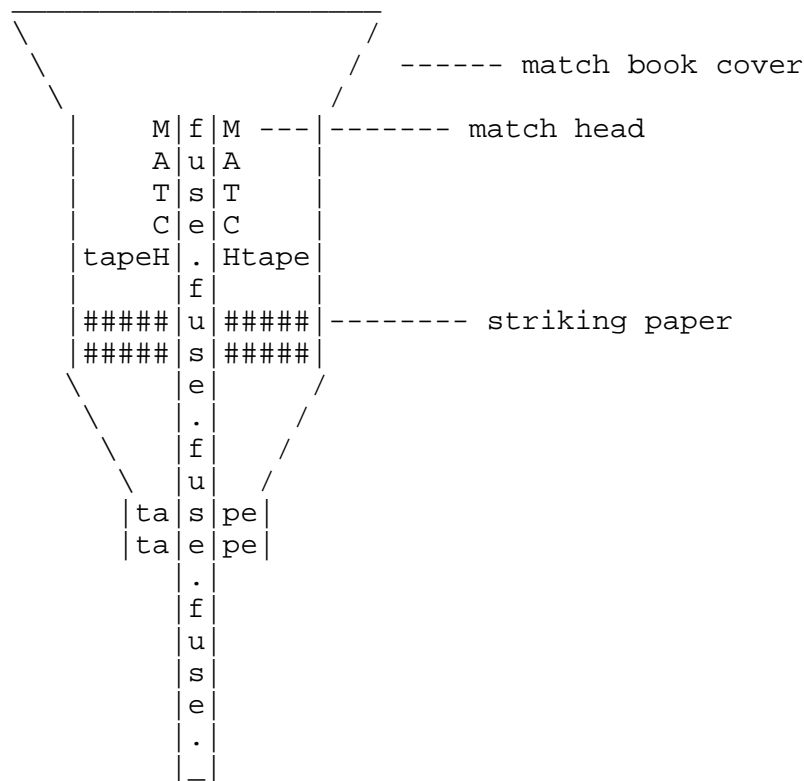

The match book is wrapped around the matches, and is taped to itself. The matches are taped to the fuse. The striker will rub against the matchheads when the match book is pulled.

- 6) When ready to use, simply pull on the match paper. It should pull the striking paper across the match heads with enough friction to light them. In turn, the burning matchheads will light the fuse, since it adjacent to the burning match heads.

#### 4.22 IMPACT IGNITION

Impact ignition is an excellent method of ignition for spontaneous terrorist activities. The problem with an impact-detonating device is that it must be kept in a very safe container so that it will not explode while being transported to the place where it is to be used. This can be done by having a removable impact initiator.

The best and most reliable impact initiator is one that uses factory made initiators or primers. A no. 11 cap for black powder firearms is one such primer. They usually come in boxes of 100, and cost about \$2.50. To use such a cap, however, one needs a nipple that it will fit on. Black powder nipples are also available in gun stores. All that a person has to do is ask for a package of nipples and the caps that fit them. Nipples have a hole that goes all the way through them, and they have a threaded end, and an end to put the cap on. A cutaway of a nipple is shown below:

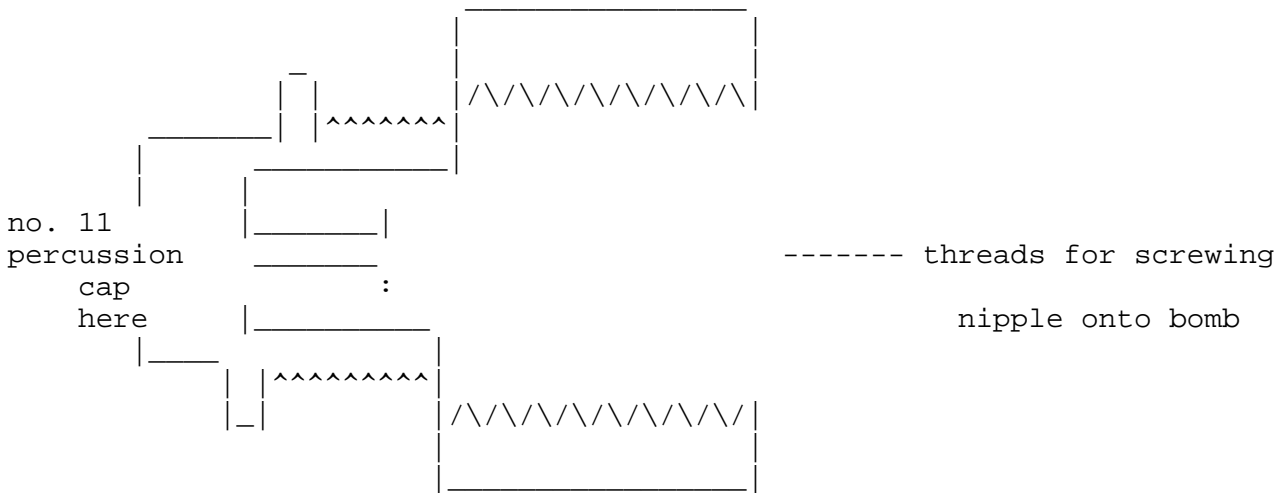

When making using this type of initiator, a hole must be drilled into whatever container is used to make the bomb out of. The nipple is then screwed into the hole so that it fits tightly. Then, the cap can be carried and placed on the bomb when it is to be thrown. The cap should be bent a small amount before it is placed on the nipple, to make sure that it stays in place. The only other problem involved with an impact detonating bomb is that it must strike a hard surface on the nipple to set it off. By attaching fins or a small parachute on the end of the bomb opposite the primer, the bomb, when thrown, should strike the ground on the primer, and explode. Of course, a bomb with mercury fulminate in each end will go off on impact regardless of which end it strikes on, but mercury fulminate is also likely to go off if the person carrying the bomb is bumped hard.

Revision by Vlad Tepes 7-29-91  
 \*\*\*\*\*

A VERY SENSITIVE and reliable impact initiator can be produced from the common MAGICUBE (\$2.40 for 12) type flashbulbs. Simply crack the plastic cover off, remove the reflector, and you will see 4 bulbs, each of which has a small metal rod holding it in place.

CAREFULLY grasp this rod with a pair of needle-nose pliers, and pry gently upwards, making sure that NO FORCE IS APPLIED TO THE GLASS BULB.

Each bulb is coated with plastic, which must be removed for them to be effective in our application. This coating can be removed by soaking the bulbs in a small glass of acetone for 30-45 minutes, at which point the plastic can be easily peeled away.

The best method to use these is to dissolve some nitrocellulose based gunpowder in acetone, forming a thick glue-like paste. Coat the end of the fuse with this paste, then stick the bulb (with the metal rod facing out) into the paste. About half the bulb should be completely covered, and if a

VERY THIN layer of nitrocellulose is coated over the remainder then ignition should be very reliable.

To insure that the device lands with the bulb down, a small streamer can be attached to the opposite side, so when it is tossed high into the air the appropriate end will hit the ground first.

\*\*\*\*

#### 4.23 ELECTRICAL IGNITION

Electrical ignition systems for detonation are usually the safest and most reliable form of ignition. Electrical systems are ideal for demolition work, if one doesn't have to worry so much about being caught. With two spools of 500 ft of wire and a car battery, one can detonate explosives from a "safe", comfortable distance, and be sure that there is nobody around that could get hurt. With an electrical system, one can control exactly what time a device will explode, within fractions of a second. Detonation can be aborted in less than a second's warning, if a person suddenly walks by the detonation sight, or if a police car chooses to roll by at the time. The two best electrical igniters are military squibs and model rocketry igniters. Blasting caps for construction also work well. Model rocketry igniters are sold in packages of six, and cost about \$1.00 per pack. All that need be done to use them is connect it to two wires and run a current through them. Military squibs are difficult to get, but they are a little bit better, since they explode when a current is run through them, whereas rocketry igniters only burst into flame. Military squibs can be used to set off sensitive high explosives, such as R.D.X., or potassium chlorate mixed with petroleum jelly.

Revision by Vlad Tepes 7-29-91

\*\*\*\*

Most squibs will NOT detonate KClO<sub>3</sub>/petroleum jelly. This requires a blasting cap type detonation in most cases. There are, however, military explosive squibs which will do the job.

\*\*\*\*

Igniters can be used to set off black powder, mercury fulminate, or guncotton, which in turn, can set off a high order explosive.

#### 4.24 ELECTRO-MECHANICAL IGNITION

Electro-mechanical ignition systems are systems that use some type of mechanical switch to set off an explosive charge electrically. This type of switch is typically used in booby traps or other devices in which the person who places the bomb does not wish to be anywhere near the device when it explodes. Several types of electro-mechanical detonators will be discussed

##### 4.241 Mercury Switches

Mercury switches are a switch that uses the fact that mercury metal conducts electricity, as do all metals, but mercury metal is a liquid at room temperatures. A typical mercury switch is a sealed glass tube with two electrodes and a bead of mercury metal. It is sealed because of mercury's nasty habit of giving off brain-damaging vapors. The diagram below may help to explain a mercury switch.

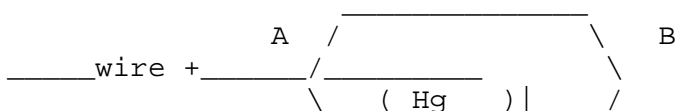

\ \_(\_Hg\_\_\_\_) |\_\_\_\_/  
wire - |

When the drop of mercury ("Hg" is mercury's atomic symbol) touches both contacts, current flows through the switch. If this particular switch was in its present position, A--B, current would be flowing, since the mercury can touch both contacts in the horizontal position.

If, however, it was in the | position, the drop of mercury would only touch the + contact on the A side. Current, then couldn't flow, since mercury does not reach both contacts when the switch is in the vertical position. This type of switch is ideal to place by a door. If it were placed in the path of a swinging door in the vertical position, the motion of the door would knock the switch down, if it was held to the ground by a piece of tape. This would tilt the switch into the vertical position, causing the mercury to touch both contacts, allowing current to flow through the mercury, and to the igniter or squib in an explosive device. Imagine opening a door and having it slammed in your face by an explosion.

#### 4.242 Tripwire Switches

A tripwire is an element of the classic booby trap. By placing a nearly invisible line of string or fishing line in the probable path of a victim, and by putting some type of trap there also, nasty things can be caused to occur. If this mode of thought is applied to explosives, how would one use such a tripwire to detonate a bomb. The technique is simple. By wrapping the tips of a standard clothespin with aluminum foil, and placing something between them, and connecting wires to each aluminum foil contact, an electric tripwire can be made. If a piece of wood attached to the tripwire was placed between the contacts on the clothespin, the clothespin would serve as a switch. When the tripwire was pulled, the clothespin would snap together, allowing current to flow between the two pieces of aluminum foil, thereby completing a circuit, which would have the igniter or squib in it. Current would flow between the contacts to the igniter or squib, heat the igniter or squib, causing it to explode.

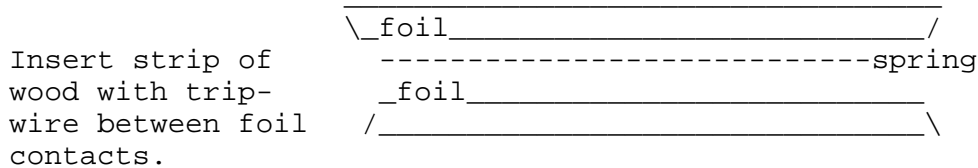

Make sure that the aluminum foil contacts do not touch the spring, since the spring also conducts electricity.

#### 4.243 Radio Control Detonators

In the movies, every terrorist or criminal uses a radio controlled detonator to set off explosives. With a good radio detonator, one can be several miles away from the device, and still control exactly when it explodes, in much the same way as an electrical switch. The problem with radio detonators is that they are rather costly. However, there could possibly be a reason that a terrorist would wish to spend the amounts of money involved with a RC (radio control) system and use it as a detonator. If such an individual wanted to devise an RC detonator, all he would need to do is visit the local hobby store or toy store, and buy a radio controlled toy. Taking it back to his/her abode, all that he/she would have to do is detach the solenoid/motor that controls the motion of the front wheels of a RC car, or detach the solenoid/motor of the elevators/rudder of a RC plane, or the rudder of a RC boat, and re-connect the squib or rocket engine igniter to the contacts for the solenoid/motor. The device should be tested several times with squibs or igniters, and fully charged batteries should be in both the controller and the receiver (the part that used to move parts before the device became a detonator).

#### 4.3 DELAYS

A delay is a device which causes time to pass from when a device is set up to the time that it explodes. A regular fuse is a delay, but it would cost quite a bit to have a 24 hour delay with a fuse. This section deals with the different types of delays that can be employed by a terrorist who wishes to be sure that his bomb will go off, but wants to be out of the country when it does.

##### 4.31 FUSE DELAYS

It is extremely simple to delay explosive devices that employ fuses for ignition. Perhaps the simplest way to do so is with a cigarette. An average cigarette burns for about 8 minutes. The higher the "tar" and nicotine rating, the slower the cigarette burns. Low "tar" and nicotine cigarettes burn quicker than the higher "tar" and nicotine cigarettes, but they are also less likely to go out if left unattended, i.e. not smoked. Depending on the wind or draft in a given place, a high "tar" cigarette is better for delaying the ignition of a fuse, but there must be enough wind or draft to give the cigarette enough oxygen to burn. People who use cigarettes for the purpose of delaying fuses will often test the cigarettes that they plan to use in advance to make sure they stay lit and to see how long it will burn. Once a cigarette's burn rate is determined, it is a simple matter of carefully putting a hole all the way through a cigarette with a toothpick at the point desired, and pushing the fuse for a device in the hole formed.

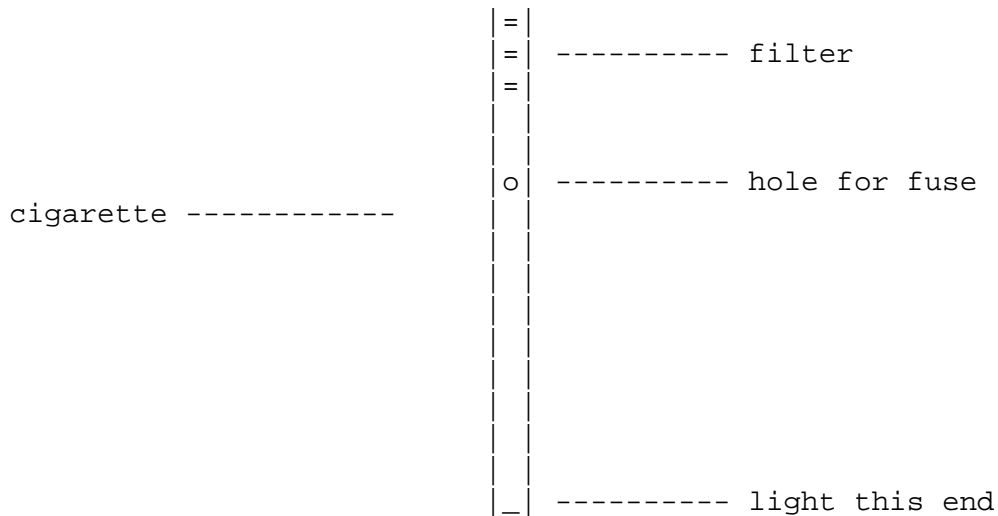

Revision 7-29-91 by Vlad Tepes

\*\*\*\*\*

A variation on the standard cigarette display was invented by my good friend Atur (THE Pyromaniac). Rather than inserting the fuse into the SIDE of the cigarette (and risk splitting it) half of the filter is cut off, and a small hole is punched THROUGH the remainder and into the tobacco.

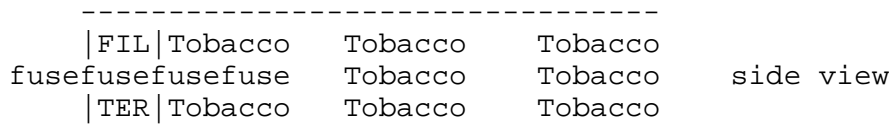

filter end view

(artwork by The Editor)

The fuse is inserted as far as possible into this hole, then taped or glued in place, or the cigarette can be cut and punched ahead of time and lit normally, then attached to the fuse at the scene.

\*\*\*\*\*

A similar type of device can be made from powdered charcoal and a sheet of paper. Simply roll the sheet of paper into a thin tube, and fill it with powdered charcoal. Punch a hole in it at the desired location, and insert a fuse. Both ends must be glued closed, and one end of the delay must be doused with lighter fluid before it is lit. Or, a small charge of gunpowder mixed with powdered charcoal could conceivably be used for igniting such a delay. A chain of charcoal briquettes can be used as a delay by merely lining up a few bricks of charcoal so that they touch each other, end on end, and lighting the first brick. Incense, which can be purchased at almost any novelty or party supply store, can also be used as a fairly reliable delay. By wrapping the fuse about the end of an incense stick, delays of up to 1/2 an hour are possible.

Finally, it is possible to make a relatively slow-burning fuse in the home. By dissolving about one teaspoon of black powder in about 1/4 a cup of boiling water, and, while it is still hot, soaking in it a long piece of all cotton string, a slow-burning fuse can be made. After the soaked string dries, it must then be tied to the fuse of an explosive device. Sometimes, the end of the slow burning fuse that meets the normal fuse has a charge of black powder

or gunpowder at the intersection point to insure ignition, since the slow-burning fuse does not burn at a very high temperature. A similar type of slow fuse can be made by taking the above mixture of boiling water and black powder and pouring it on a long piece of toilet paper. The wet toilet paper is then gently twisted up so that it resembles a firecracker fuse, and is allowed to dry.

#### 4.32 TIMER DELAYS

Timer delays, or "time bombs" are usually employed by an individual who wishes to threaten a place with a bomb and demand money to reveal its location and means to disarm it. Such a device could be placed in any populated place if it were concealed properly. There are several ways to build a timer delay. By simply using a screw as one contact at the time that detonation is desired, and using the hour hand of a clock as the other contact, a simple timer can be made. The minute hand of a clock should be removed, unless a delay of less than an hour is desired.

The main disadvantage with this type of timer is that it can only be set for a maximum time of 12 hours. If an electronic timer is used, such as that in an electronic clock, then delays of up to 24 hours are possible. By removing the speaker from an electronic clock, and attaching the wires of a squib or igniter to them, a timer with a delay of up to 24 hours can be made. All that one has to do is set the alarm time of the clock to the desired time, connect the leads, and go away. This could also be done with an electronic watch, if a larger battery were used, and the current to the speaker of the watch was stepped up via a transformer. This would be good, since such a timer could be extremely small.

The timer in a VCR (Video Cassette Recorder) would be ideal. VCR's can usually be set for times of up to a week. The leads from the timer to the recording equipment would be the ones that an igniter or squib would be connected to. Also, one can buy timers from electronics stores that would be work well. Finally, one could employ a digital watch, and use a relay, or electro-magnetic switch to fire the igniter, and the current of the watch would not have to be stepped up.

#### 4.33 CHEMICAL DELAYS

Chemical delays are uncommon, but they can be extremely effective in some cases. If a glass container is filled with concentrated sulfuric acid, and capped with several thicknesses of aluminum foil, or a cap that it will eat through, then it can be used as a delay. Sulfuric acid will react with aluminum foil to produce aluminum sulfate and hydrogen gas, and so the container must be open to the air on one end so that the pressure of the hydrogen gas that is forming does not break the container.

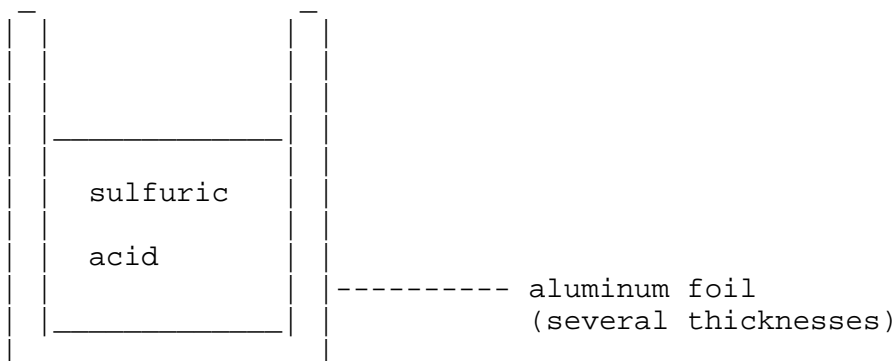

The aluminum foil is placed over the bottom of the container and secured there with tape. When the acid eats through the aluminum foil, it can be used to ignite an explosive device in several ways.

1) Sulfuric acid is a good conductor of electricity. If the acid that eats through the foil is collected in a glass container placed underneath the foil, and two wires are placed in the glass container, a current will be able to flow through the acid when both of the wires are immersed in the acid.

2) Sulfuric acid reacts very violently with potassium chlorate. If the acid drips down into a container containing potassium chlorate, the potassium chlorate will burst into flame. This flame can be used to ignite a fuse, or the potassium chlorate can be the igniter for a thermite bomb, if some potassium chlorate is mixed in a 50/50 ratio with the thermite, and this mixture is used as an igniter for the rest of the thermite.

3) Sulfuric acid reacts with potassium permanganate in a similar way.

#### 4.4 EXPLOSIVE CASINGS

This section will cover everything from making a simple firecracker to a complicated scheme for detonating an insensitive high explosive, both of which are methods that could be utilized by perpetrators of terror.

## 4.41 PAPER CONTAINERS

Paper was the first container ever used for explosives, since it was first used by the Chinese to make fireworks. Paper containers are usually very simple to make, and are certainly the cheapest. There are many possible uses for paper in containing explosives, and the two most obvious are in firecrackers and rocket engines. Simply by rolling up a long sheet of paper, and gluing it together, one can make a simple rocket engine. Perhaps a more interesting and dangerous use is in the firecracker. The firecracker shown here is one of Mexican design. It is called a "polumna", meaning "dove". The process of their manufacture is not unlike that of making a paper football. If one takes a sheet of paper about 16 inches in length by 1.5 inches wide, and fold one corner so that it looks like this:

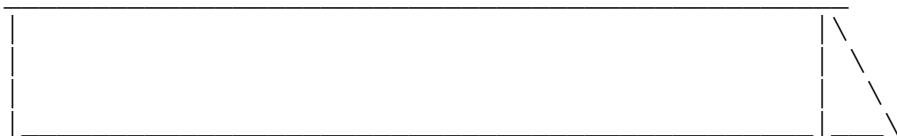

and then fold it again so that it looks like this:

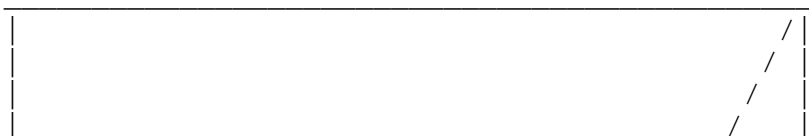

A pocket is formed. This pocket can be filled with black powder, pyrodex, flash powder, gunpowder, rocket engine powder, or any of the quick-burning fuel-oxidizer mixtures that occur in the form of a fine powder.

A fuse is then inserted, and one continues the triangular folds, being careful not to spill out any of the explosive. When the polumna is finished, it should be taped together very tightly, since this will increase the strength of the container, and produce a louder and more powerful explosion when it is lit. The finished polumna should look like a 1/4 inch - 1/3 inch thick triangle, like the one shown below:

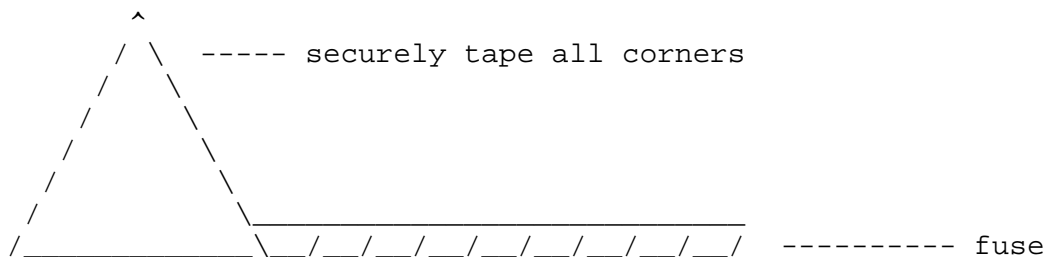

## 4.42 METAL CONTAINERS

The classic pipe bomb is the best known example of a metal-contained explosive. Idiot anarchists take white tipped matches and cut off the match heads. They pound one end of a pipe closed with a hammer, pour in the white-tipped matches, and then pound the other end closed. This process often kills the fool, since when he pounds the pipe closed, he could very easily cause enough friction between the match heads to cause them to ignite and explode the unfinished bomb. By using pipe caps, the process is somewhat safer, and the less stupid anarchist would never use white tipped matches in a bomb.

He would buy two pipe caps and threaded pipe (fig. 1). First, he would drill a hole in one pipe cap, and put a fuse in it so that it will not come out, and so powder will not escape during handling. The fuse would be at least 3/4 an inch long inside the bomb. He would then screw the cap with the fuse in it on tightly, possibly putting a drop of super glue on it to hold it tight. He would then pour his explosive powder in the bomb. To pack it tightly, he would take a large wad of tissue paper and, after filling the pipe to the very top, pack the powder down, by using the paper as a ramrod tip, and pushing it with a pencil or other wide ended object, until it would not move any further.

Finally, he would screw the other pipe cap on, and glue it. The tissue paper would help prevent some of the powder from being caught in the threads of the pipe or pipe cap from being crushed and subject to friction, which might ignite the powder, causing an explosion during manufacture. An assembled bomb is shown in fig. 2.

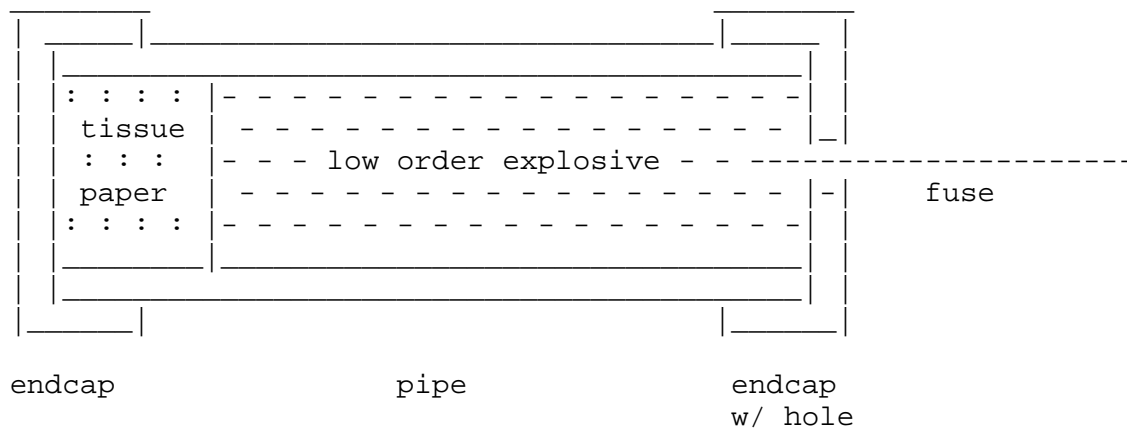

fig. 2 Assembled pipe bomb.

Revision 7-29-91 by Vlad Tepes

\*\*\*\*\*

> The metal caps are VERY difficult to drill holes in, it is much easier to  
>drill a hole into the middle of the pipe (BEFORE FILLING IT!!!) and place  
>the fuse there. L----- R. (a friend of mine) has had great success with  
>this design. After detonating one of these inside a cookie tin, he found  
>the lid about 1/2 block away, the sides of the tin blown out, and an  
>impression of the pipe (which was later found blown flat) threads and all  
>on the bottom of the tin... it seems that the welded seam gives out on  
>most modern rolled pipes, however a cast pipe (no seam) would produce  
>more shrapnel (which may or may not be desirable.

\*\*\*\*\*

This is one possible design that a mad bomber would use. If, however, he did not have access to threaded pipe with endcaps, he could always use a piece of copper or aluminum pipe, since it is easily bent into a suitable position. A major problem with copper piping, however, is bending and folding it without tearing it; if too much force is used when folding and bending copper pipe, it will split along the fold. The safest method for making a pipe bomb out of copper or aluminum pipe is similar to the method with pipe and endcaps.

First, one flattens one end of a copper or aluminum pipe carefully, making sure not to tear or rip the piping. Then, the flat end of the pipe should be folded over at least once, if this does not rip the pipe. A fuse hole should be drilled in the pipe near the now closed end, and the fuse should be inserted.

Next, the bomb-builder would fill the bomb with a low order explosive, and pack it with a large wad of tissue paper. He would then flatten and fold the other end of the pipe with a pair of pliers. If he was not too dumb, he would do this slowly, since the process of folding and bending metal gives off heat, which could set off the explosive. A diagram is presented below:

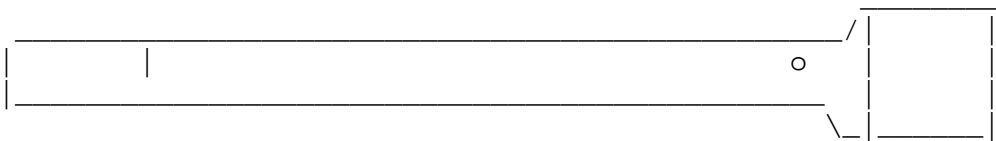

fig. 1 pipe with one end flattened and fuse hole drilled (top view)

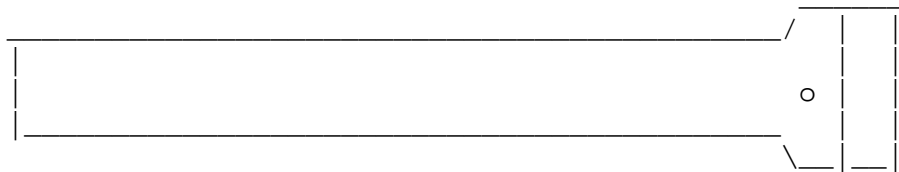

fig. 2 pipe with one end flattened and folded up (top view)

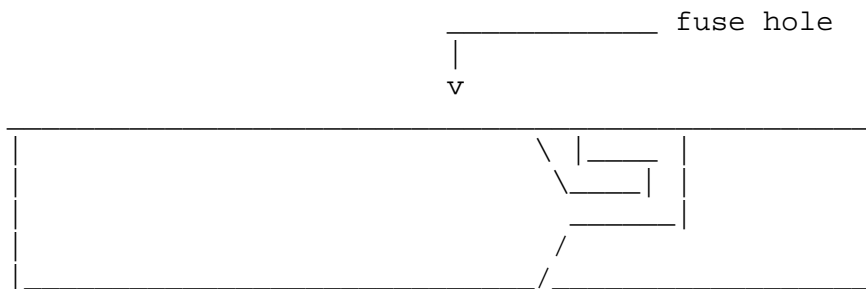

fig. 3 pipe with flattened and folded end (side view)

A CO2 cartridge from a B.B gun is another excellent container for a low-order explosive. It has one minor disadvantage: it is time consuming to fill. But this can be rectified by widening the opening of the cartridge with a pointed tool. Then, all that would have to be done is to fill the CO2 cartridge with any low-order explosive, or any of the fast burning fuel-oxidizer mixtures, and insert a fuse. These devices are commonly called "crater makers".

Addendum 4/12/91:

From personal experience, I have found that a CO2 cartridge is easiest to fill if you take a piece of paper and tape it around the opening to form a sort of funnel:

A full cartridge can also be fun-  
 \ / Use a punch or sharp philips (+) screwdriver to  
 \ / enlarge the pin-hole opening on a used cartridge.  
 @ It doesn't seem to be necessary to seal the hole,  
 / \ but if you must do so, Epoxy and electrical tape  
 | | work quite well.  
 | |  
 ( ) CONDENSATION may form inside a recently used  
 bottle- if you must use one right after emptying  
 it, heat it in a warm oven to dry it out.  
 toss it into a lite fire and it will explode, and the CO2 may extinguish the flames.

\*End Addendum

A CO2 cartridge also works well as a container for a thermite incendiary device, but it must be modified. The opening in the end must be widened, so that the ignition mixture, such as powdered magnesium, does not explode. The fuse will ignite the powdered magnesium, which, in turn, would ignite the thermite .

The previously mentioned designs for explosive devices are fine for low-order explosives, but are unsuitable for high-order explosives, since the latter requires a shockwave to be detonated. A design employing a smaller low-order explosive device inside a larger device containing a high-order explosive would probably be used.

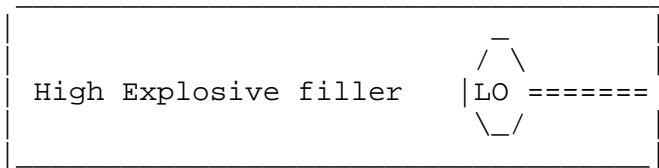

If the large high explosive container is small, such as a CO2 cartridge, then a segment of a hollow radio antenna can be made into a low-order pipe bomb, which can be fitted with a fuse, and inserted into the CO2 cartridge.

#### 4.43 GLASS CONTAINERS

Glass containers can be suitable for low-order explosives, but there are problems with them. First, a glass container can be broken relatively easily compared to metal or plastic containers. Secondly, in the not-too-unlikely event of an "accident", the person making the device would probably be seriously injured, even if the device was small. A bomb made out of a sample perfume bottle-sized container exploded in the hands of one boy, and he still has pieces of glass in his hand. He is also missing the final segment of his ring finger, which was cut off by a sharp piece of flying glass...

Nonetheless, glass containers such as perfume bottles can be used by a demented individual, since such a device would not be detected by metal detectors in an airport or other public place. All that need be done is fill the container, and drill a hole in the plastic cap that the fuse fits tightly in, and screw the cap-fuse assembly on.

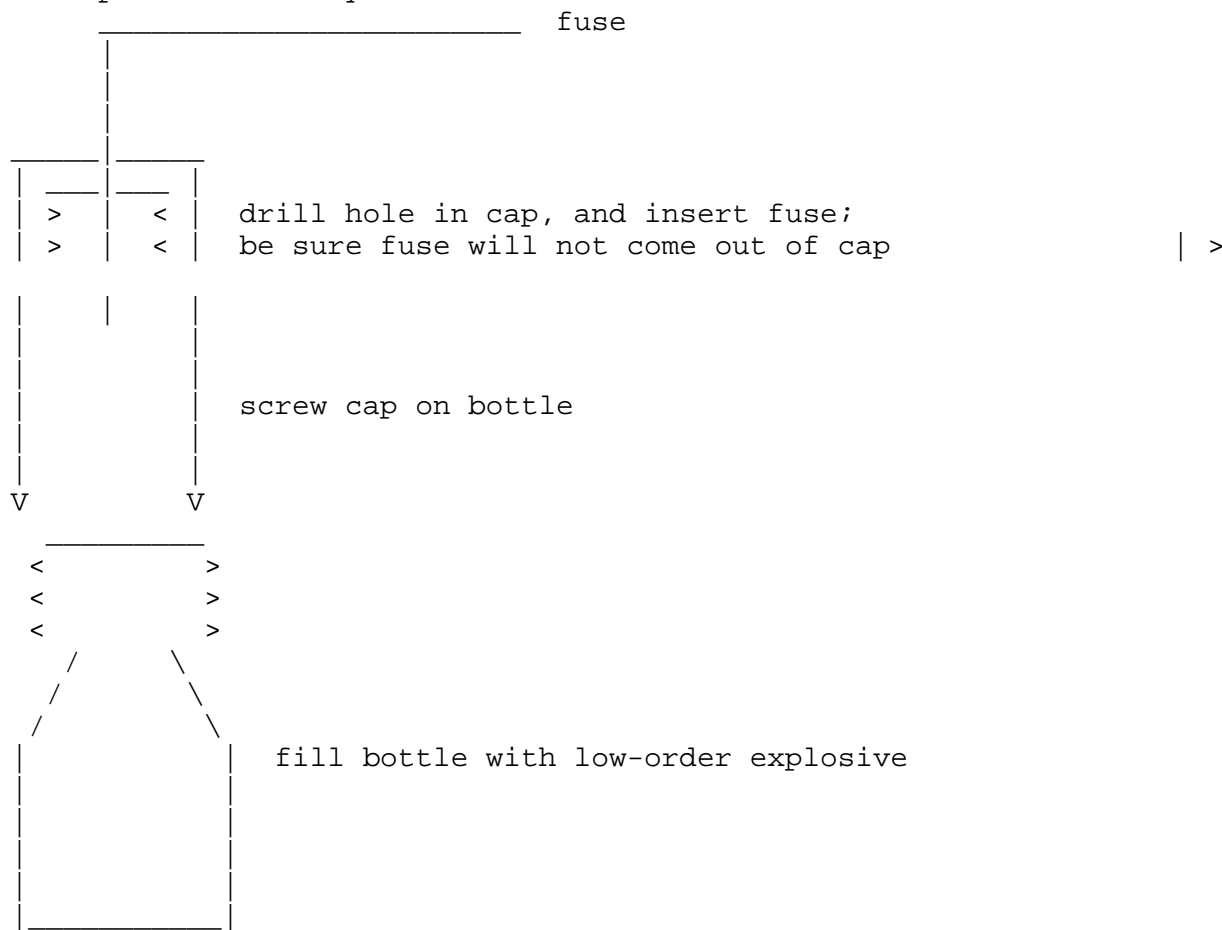

Large explosive devices made from glass containers are not practical, since glass is not an exceptionally strong container. Much of the explosive that is used to fill the container is wasted if the container is much larger than a 16 oz. soda bottle. Also, glass containers are usually unsuitable for high explosive devices, since a glass container would probably not withstand the explosion of the initiator; it would shatter before the high explosive was able to detonate.

#### 4.44 PLASTIC CONTAINERS

Plastic containers are perhaps the best containers for explosives, since they can be any size or shape, and are not fragile like glass. Plastic piping can be bought at hardware or plumbing stores, and a device much like the ones used for metal containers can be made. The high-order version works well with plastic piping. If the entire device is made out of plastic, it is not detectable by metal detectors. Plastic containers can usually be shaped by heating the container, and bending it at the appropriate place. They can be glued closed with epoxy or other cement for plastics. Epoxy alone can be used as an endcap, if a wad of tissue paper is placed in the piping. Epoxy with a drying agent works best in this type of device.

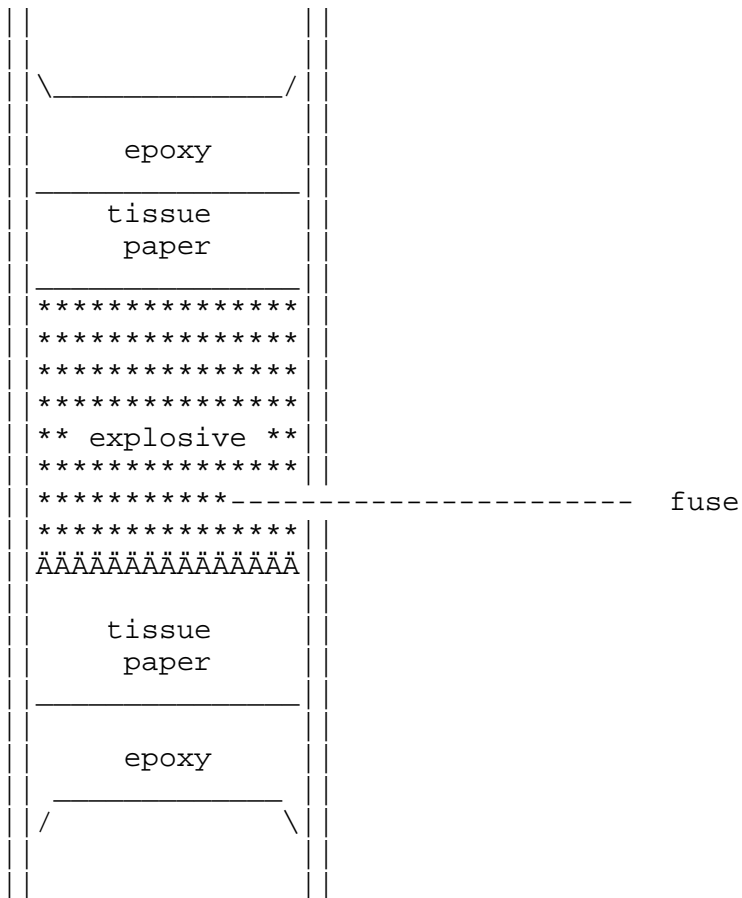

One end must be made first, and be allowed to dry completely before the device can be filled with powder and fused. Then, with another piece of tissue paper, pack the powder tightly, and cover it with plenty of epoxy. PVC pipe works well for this type of device, but it cannot be used if the pipe had an inside diameter greater than 3/4 of an inch. Other plastic puttys can be used in this type of device, but epoxy with a drying agent works best.

Addendum 4/12/91:

In my experience, epoxy plugs work well, but epoxy is somewhat expensive. One alternative is auto body filler, a grey paste which, when mixed with hardener, forms into a rock-like mass which is stronger than most epoxy. The only drawback is the body filler generates quite a bit of heat as it hardens, which might be enough to set off a overly sensitive explosive.

One benefit of body filler is that it will hold it's shape quite well, and is ideal for forming rocket nozzles and entire bomb casings.

\*End Addendum

#### 4.5 ADVANCED USES FOR EXPLOSIVES

The techniques presented here are those that could be used by a person who had some degree of knowledge of the use of explosives. Some of this information comes from demolitions books, or from military handbooks. Advanced uses for explosives usually involved shaped charges, or utilize a minimum amount of explosive to do a maximum amount of damage. They almost always involve high- order explosives.

##### 4.51 SHAPED CHARGES

A shaped charge is an explosive device that, upon detonation, directs the explosive force of detonation at a small target area. This process can be used to breach the strongest armor, since forces of literally millions of pounds of pressure per square inch can be generated. Shaped charges employ high-order explosives, and usually electric ignition systems. KEEP IN MIND THAT ALL EXPLOSIVES ARE DANGEROUS, AND SHOULD NEVER BE MADE OR USED!!

An example of a shaped charge is shown below.

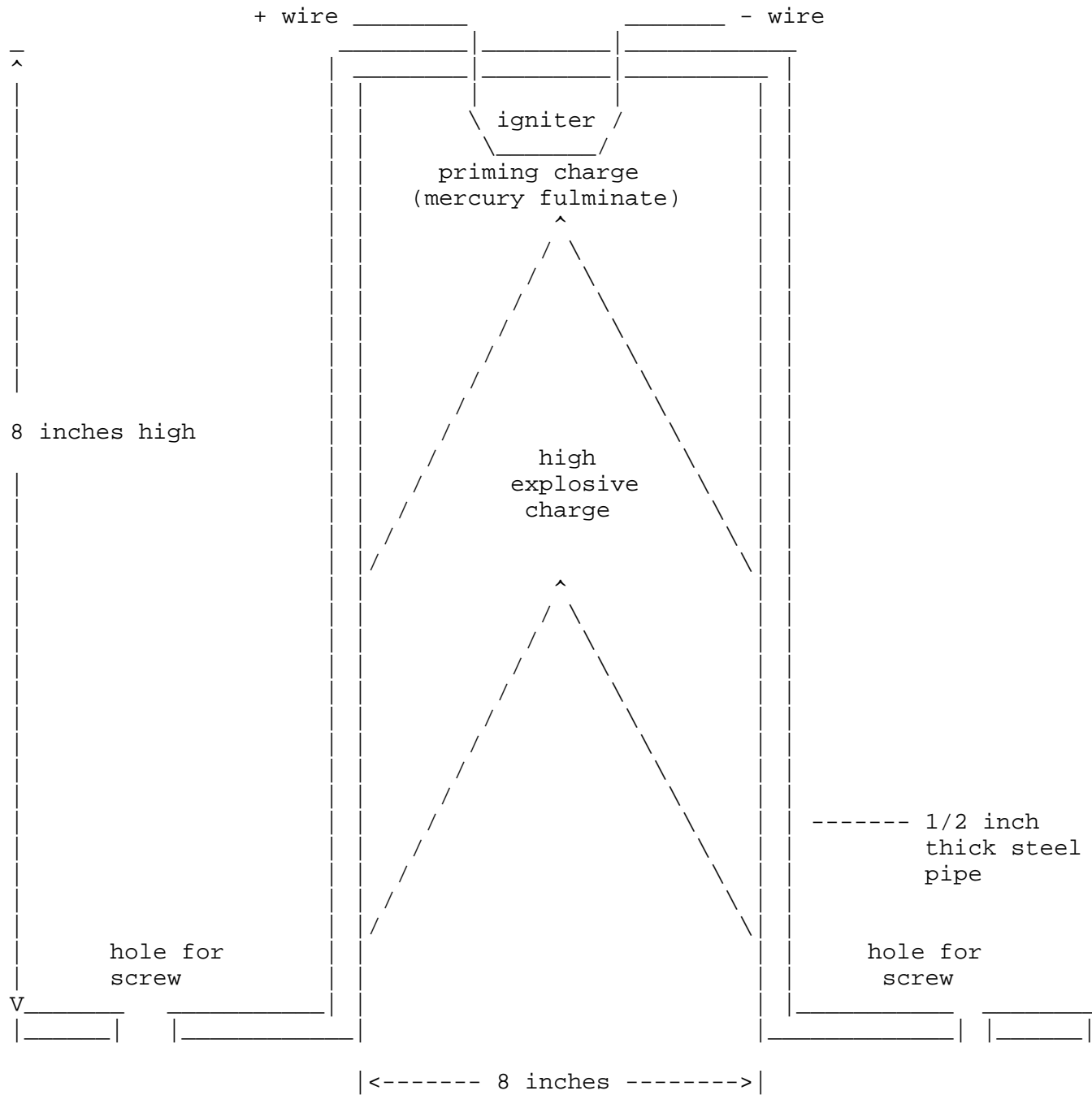

If a device such as this is screwed to a safe, for example, it would direct most of the explosive force at a point about 1 inch away from the opening of the pipe. The basis for shaped charges is a cone-shaped opening in the explosive material. This cone should have an angle of 45 degrees. A device such as this one could also be attached to a metal surface with a powerful electromagnet.

4.52 TUBE EXPLOSIVES

A variation on shaped charges, tube explosives can be used in ways that shaped charges cannot. If a piece of 1/2 inch plastic tubing was filled with a sensitive high explosive like R.D.X., and prepared as the plastic explosive container in section 4.44, a different sort of shaped charge could be produced; a charge that directs explosive force in a circular manner. This type of explosive could be wrapped around a column, or a doorknob, or a telephone pole. The explosion would be directed in and out, and most likely destroy whatever it was wrapped around. In an unbent state, a tube explosive would look like this:

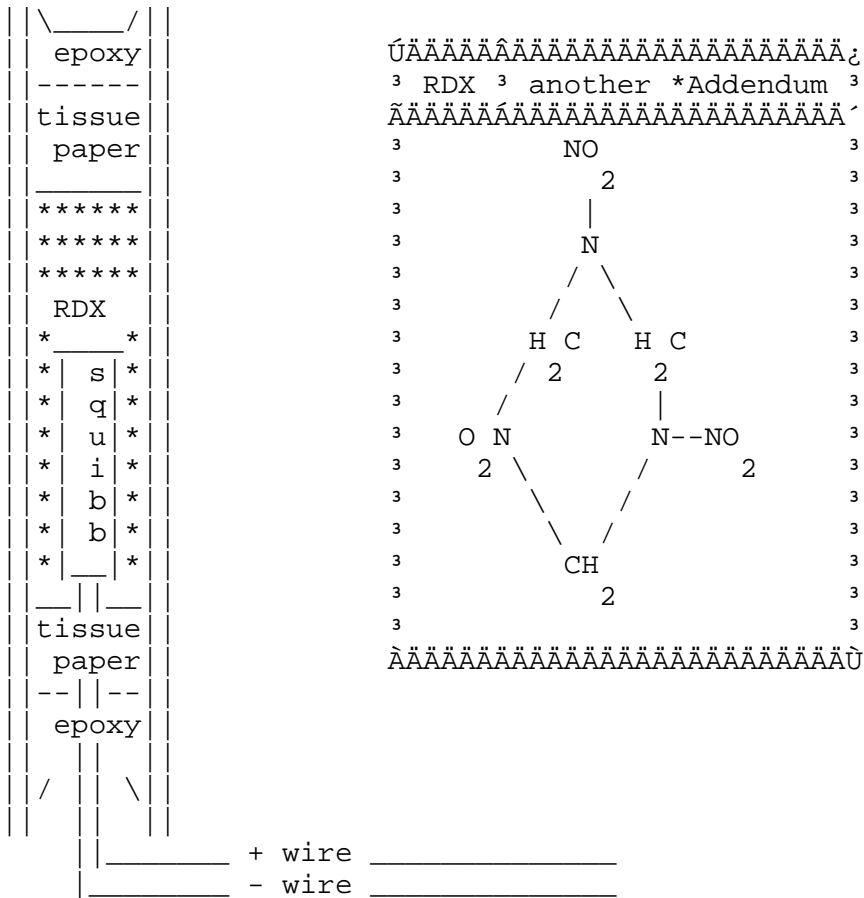

When an assassin or terrorist wishes to use a tube bomb, he must wrap it around whatever thing he wishes to destroy, and epoxy the ends of the tube bomb together. After it dries, he/she can connect wires to the squib wires, and detonate the bomb, with any method of electric detonation.

#### 4.53 ATOMIZED PARTICLE EXPLOSIONS

If a highly flammable substance is atomized, or, divided into very small particles, and large amounts of it is burned in a confined area, an explosion similar to that occurring in the cylinder of an automobile is produced. The tiny droplets of gasoline burn in the air, and the hot gasses expand rapidly, pushing the cylinder up. Similarly, if a gallon of gasoline was atomized and ignited in a building, it is very possible that the expanding gasses would push the walls of the building down. This phenomenon is called an atomized particle explosion.

If a person can effectively atomize a large amount of a highly flammable substance and ignite it, he could bring down a large building, bridge, or other structure. Atomizing a large amount of gasoline, for example, can be extremely difficult, unless one has the aid of a high explosive. If a gallon jug of gasoline was placed directly over a high explosive charge, and the charge was detonated, the gasoline would instantly be atomized and ignited. If this occurred in a building, for example, an atomized particle explosion would surely occur. Only a small amount of high explosive would be necessary to accomplish this feat, about 1/2 a pound of T.N.T. or 1/4 a pound of R.D.X. Also, instead of gasoline, powdered aluminum could be used. It is necessary that a high explosive be used to atomize a flammable material, since a low-order explosion does not occur quickly enough to atomize or ignite the flammable material.

#### 4.54 LIGHTBULB BOMBS

An automatic reaction to walking into a dark room is to turn on the light. This can be fatal, if a lightbulb bomb has been placed in the overhead light socket. A lightbulb bomb is surprisingly easy to make. It also comes with its own initiator and electric ignition system. On some lightbulbs, the lightbulb glass can be removed from the metal base by heating the base of a lightbulb in a gas flame, such as that of a blowtorch or gas stove. This must be done carefully, since the inside of a lightbulb is a vacuum. When the glue gets hot enough, the glass bulb can be pulled off the metal base. On other bulbs, it is necessary to heat the glass directly with a blowtorch or oxy-acetylene torch. In either case, once the bulb and/or base has cooled down to room temperature or lower, the bulb can be filled with an explosive material, such as black powder. If the glass was removed from the metal base, it must be glued back on to the base with epoxy. If a hole was put in the bulb, a piece of duct tape is sufficient to hold the explosive in the in the bulb. Then, after making sure that the socket has no power by checking with a working lightbulb, all that need be done is to screw the lightbulb bomb into the socket. Such a device has been used by terrorists or assassins with much success, since nobody can search the room for a bomb without first turning on the light.

## 4.55 BOOK BOMBS

Concealing a bomb can be extremely difficult in a day and age where perpetrators of violence run wild. Bags and briefcases are often searched by authorities whenever one enters a place where an individual might intend to set off a bomb. One approach to disguising a bomb is to build what is called a book bomb; an explosive device that is entirely contained inside of a book.

Usually, a relatively large book is required, and the book must be of the hardback variety to hide any protrusions of a bomb. Dictionaries, law books, large textbooks, and other such books work well. When an individual makes a bookbomb, he/she must choose a type of book that is appropriate for the place where the book bomb will be placed. The actual construction of a book bomb can be done by anyone who possesses an electric drill and a coping saw.

First, all of the pages of the book must be glued together. By pouring an entire container of water-soluble glue into a large bucket, and filling the bucket with boiling water, a glue-water solution can be made that will hold all of the book's pages together tightly. After the glue-water solution has cooled to a bearable temperature, and the solution has been stirred well, the pages of the book must be immersed in the glue-water solution, and each page must be thoroughly soaked.

It is extremely important that the covers of the book do not get stuck to the pages of the book while the pages are drying. Suspending the book by both covers and clamping the pages together in a vice works best. When the pages dry, after about three days to a week, a hole must be drilled into the now rigid pages, and they should drill out much like wood. Then, by inserting the coping saw blade through the pages and sawing out a rectangle from the middle of the book, the individual will be left with a shell of the book's pages. The pages, when drilled out, should look like this:

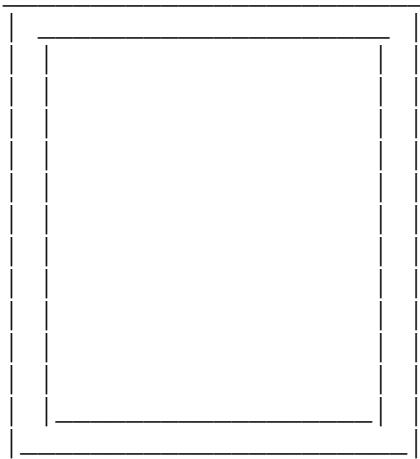

(book covers omitted)

This rectangle must be securely glued to the back cover of the book. After building his/her bomb, which usually is of the timer or radio controlled variety, the bomber places it inside the book. The bomb itself, and whatever timer or detonator is used, should be packed in foam to prevent it from rolling or shifting about. Finally, after the timer is set, or the radio control has been turned on, the front cover is glued closed, and the bomb is taken to its destination.

#### 4.56 PHONE BOMBS

The phone bomb is an explosive device that has been used in the past to kill or injure a specific individual. The basic idea is simple: when the person answers the phone, the bomb explodes. If a small but powerful high explosive device with a squib was placed in the phone receiver, when the current flowed through the receiver, the squib would explode, detonating the high explosive in the person's hand. Nasty. All that has to be done is acquire a squib, and tape the receiver switch down.

Unscrew the mouthpiece cover, and remove the speaker, and connect the squib's leads where it was. Place a high explosive putty, such as C-1 (see section 3.31) in the receiver, and screw the cover on, making sure that the squib is surrounded by the C-1. Hang the phone up, and leave the tape in place.

When the individual to whom the phone belongs attempts to answer the phone, he will notice the tape, and remove it. This will allow current to flow through the squib. Note that the device will not explode by merely making a phone call; the owner of the phone must lift up the receiver, and remove the tape. It is highly probable that the phone will be by his/her ear when the device explodes...

Addendum 4/12/91:

The above seems overly complicated to me... it would be better to rig the device as follows:

#### FIRST UNPLUG THE PHONE FROM THE WALL

```

/|-----|\  Wire the detonator IN LINE with the wires going to the earpiece,
~ | | ~      (may need to wire it with a relay so the detonator can receive
@@@@@@@@    the full line power, not just to audio power to the earpiece)
@@@@@@@@
@@@@@@@@    Pack C4 into the phone body (NOT the handset) and plug it back
in. When they pick up the phone, power will flow through the
circuit to the detonator....

```

## 5.0 SPECIAL AMMUNITION FOR PROJECTILE WEAPONS

Explosive and/or poisoned ammunition is an important part of a social deviant's arsenal. Such ammunition gives the user a distinct advantage over individual who use normal ammunition, since a grazing hit is good enough to kill. Special ammunition can be made for many types of weapons, from crossbows to shotguns.

## 5.1 SPECIAL AMMUNITION FOR PRIMITIVE WEAPONS

For the purposes of this publication, we will call any weapon primitive that does not employ burning gunpowder to propel a projectile forward. This means blowguns, bows and crossbows, and wristrockets.

### 5.11 BOW AND CROSSBOW AMMUNITION

Bows and crossbows both fire arrows or bolts as ammunition. It is extremely simple to poison an arrow or bolt, but it is a more difficult matter to produce explosive arrows or bolts. If, however, one can acquire aluminum piping that is the same diameter of an arrow or crossbow bolt, the entire segment of piping can be converted into an explosive device that detonates upon impact, or with a fuse.

All that need be done is find an aluminum tube of the right length and diameter, and plug the back end with tissue paper and epoxy. Fill the tube with any type of low-order explosive or sensitive high-order explosive up to about 1/2 an inch from the top.

Cut a slot in the piece of tubing, and carefully squeeze the top of the tube into a round point, making sure to leave a small hole. Place a no. 11 percussion cap over the hole, and secure it with super glue.

Finally, wrap the end of the device with electrical or duct tape, and make fins out of tape. Or, fins can be bought at a sporting goods store, and glued to the shaft. The finished product should look like:

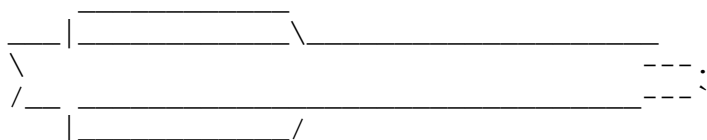

When the arrow or bolt strikes a hard surface, the percussion cap explodes, igniting or detonating the explosive.

5.12 SPECIAL AMMUNITION FOR BLOWGUNS

The blowgun is an interesting weapon which has several advantages. A blowgun can be extremely accurate, concealable, and deliver an explosive or poisoned projectile. The manufacture of an explosive dart or projectile is not difficult.

Perhaps the most simple design for such involves the use of a pill capsule, such as the kind that are taken for headaches or allergies. Such a capsule could easily be opened, and the medicine removed. Next, the capsule would be re-filled with an impact-sensitive explosive. An additional high explosive charge could be placed behind the impact-sensitive explosive, if one of the larger capsules were used.

Finally, the explosive capsule would be reglued back together, and a tassel or cotton would be glued to the end containing the high explosive, to insure that the impact-detonating explosive struck the target first.

Such a device would probably be about 3/4 of an inch long, not including the tassel or cotton, and look something like this:

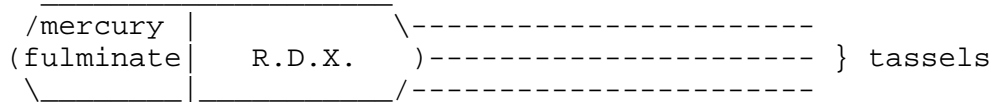

## 5.13 SPECIAL AMMUNITION FOR WRISTROCKETS AND SLINGSHOTS

A modern wristrocket is a formidable weapon. It can throw a shooter marble about 500 ft. with reasonable accuracy. Inside of 200 ft., it could well be lethal to a man or animal, if it struck in a vital area. Because of the relatively large sized projectile that can be used in a wristrocket, the wristrocket can be adapted to throw relatively powerful explosive projectiles.

A small segment of aluminum pipe could be made into an impact-detonating device by filling it with an impact-sensitive explosive material.

Also, such a pipe could be filled with a low-order explosive, and fitted with a fuse, which would be lit before the device was shot. One would have to make sure that the fuse was of sufficient length to insure that the device did not explode before it reached its intended target.

Finally, .22 caliber caps, such as the kind that are used in .22 caliber blank guns, make excellent exploding ammunition for wristrockets, but they must be used at a relatively close range, because of their light weight.

## 5.2 SPECIAL AMMUNITION FOR FIREARMS

When special ammunition is used in combination with the power and rapidity of modern firearms, it becomes very easy to take on a small army with a single weapon. It is possible to buy explosive ammunition, but that can be difficult to do. Such ammunition can also be manufactured in the home. There is, however, a risk involved with modifying any ammunition. If the ammunition is modified incorrectly, in such a way that it makes the bullet even the slightest bit wider, an explosion in the barrel of the weapon will occur. For this reason, NOBODY SHOULD EVER ATTEMPT TO MANUFACTURE SUCH AMMUNITION.

## 5.21 SPECIAL AMMUNITION FOR HANDGUNS

If an individual wished to produce explosive ammunition for his/her handgun, he/she could do it, provided that the person had an impact-sensitive explosive and a few simple tools. One would first purchase all lead bullets, and then make or acquire an impact-detonating explosive. By drilling a hole in a lead bullet with a drill, a space could be created for the placement of an explosive. After filling the hole with an explosive, it would be sealed in the bullet with a drop of hot wax from a candle. A diagram of a completed exploding bullet is shown below.

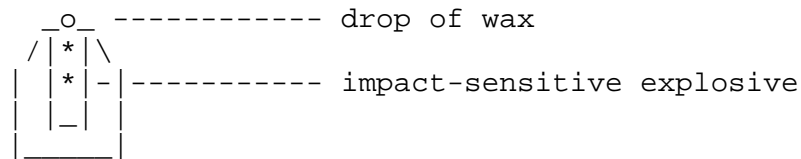

This hollow space design also works for putting poison in bullets.

## 5.22 SPECIAL AMMUNITION FOR SHOTGUNS

Because of their large bore and high power, it is possible to create some extremely powerful special ammunition for use in shotguns. If a shotgun shell is opened at the top, and the shot removed, the shell can be re-closed. Then, if one can find a very smooth, lightweight wooden dowel that is close to the bore width of the shotgun, a person can make several types of shotgun-launched weapons.

Insert the dowel in the barrel of the shotgun with the shell without the shot in the firing chamber. Mark the dowel about six inches away from the end of the barrel, and remove it from the barrel.

Next, decide what type of explosive or incendiary device is to be used. This device can be a chemical fire bottle (sect. 3.43), a pipe bomb (sect 4.42), or a thermite bomb (sect 3.41 and 4.42). After the device is made, it must be securely attached to the dowel. When this is done, place the dowel back in the shotgun. The bomb or incendiary device should be on the end of the dowel.

Make sure that the device has a long enough fuse, light the fuse, and fire the shotgun. If the projectile is not too heavy, ranges of up to 300 ft are possible. A diagram of a shotgun projectile is shown below:

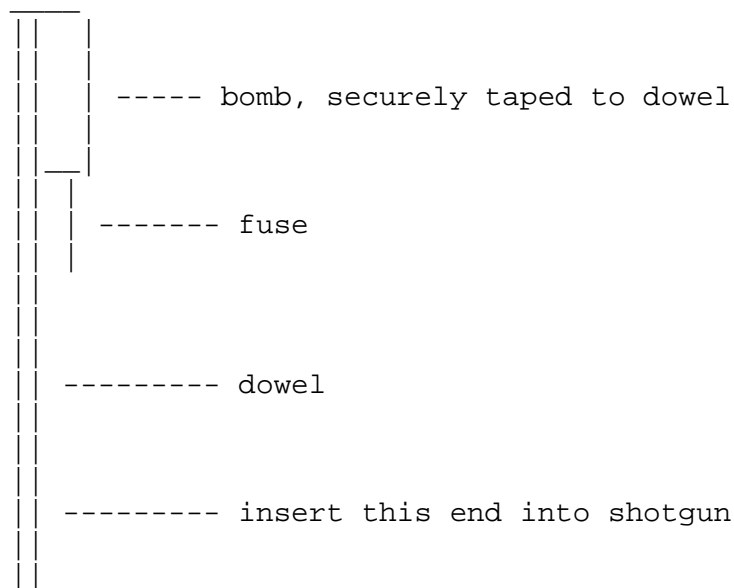

## 5.3 SPECIAL AMMUNITION FOR COMPRESSED AIR/GAS WEAPONS

This section deals with the manufacture of special ammunition for compressed air or compressed gas weapons, such as pump B.B guns, CO2 B.B guns, and .22 cal pellet guns. These weapons, although usually thought of as kids toys, can be made into rather dangerous weapons.

## 5.31 SPECIAL AMMUNITION FOR B.B GUNS

A B.B gun, for this manuscript, will be considered any type of rifle or pistol that uses compressed air or CO2 gas to fire a projectile with a caliber of .177, either B.B, or lead pellet. Such guns can have almost as high a muzzle velocity as a bullet-firing rifle. Because of the speed at which a .177 caliber projectile flies, an impact detonating projectile can easily be made that has a caliber of .177.

Most ammunition for guns of greater than .22 caliber use primers to ignite the powder in the bullet. These primers can be bought at gun stores, since many people like to reload their own bullets. Such primers detonate when struck by the firing pin of a gun. They will also detonate if they are thrown at a hard surface at a great speed.

Usually, they will also fit in the barrel of a .177 caliber gun. If they are inserted flat end first, they will detonate when the gun is fired at a hard surface. If such a primer is attached to a piece of thin metal tubing, such as that used in an antenna, the tube can be filled with an explosive, be sealed, and fired from a B.B gun. A diagram of such a projectile appears below:

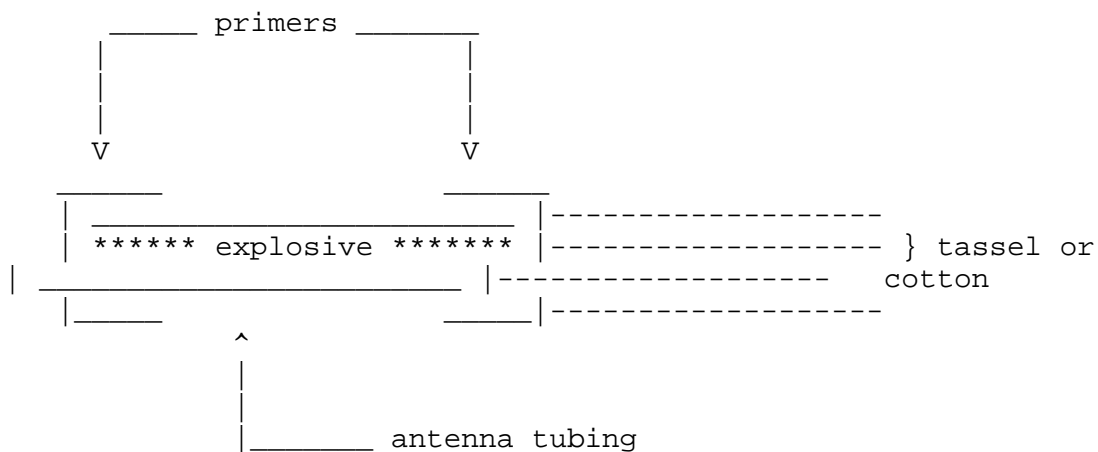

The front primer is attached to the tubing with a drop of super glue. The tubing is then filled with an explosive, and the rear primer is glued on. Finally, a tassel, or a small piece of cotton is glued to the rear primer, to insure that the projectile strikes on the front primer. The entire projectile should be about 3/4 of an inch long.

5.32 SPECIAL AMMUNITION FOR .22 CALIBER PELLET GUNS

A .22 caliber pellet gun usually is equivalent to a .22 cal rifle, at close ranges. Because of this, relatively large explosive projectiles can be adapted for use with .22 caliber air rifles. A design similar to that used in section 5.12 is suitable, since some capsules are about .22 caliber or smaller. Or, a design similar to that in section 5.31 could be used, only one would have to purchase black powder percussion caps, instead of ammunition primers, since there are percussion caps that are about .22 caliber. A #11 cap is too small, but anything larger will do nicely.

6.0 ROCKETS AND CANNONS

Rockets and cannon are generally thought of as heavy artillery. Perpetrators of violence do not usually employ such devices, because they are difficult or impossible to acquire. They are not, however, impossible to make. Any individual who can make or buy black powder or pyrodex can make such things. A terrorist with a cannon or large rocket is, indeed, something to fear.

6.1 ROCKETS

Rockets were first developed by the Chinese several hundred years before the myth of christ began. They were used for entertainment, in the form of fireworks. They were not usually used for military purposes because they were inaccurate, expensive, and unpredictable. In modern times, however, rockets are used constantly by the military, since they are cheap, reliable, and have no recoil. Perpetrators of violence, fortunately, cannot obtain military rockets, but they can make or buy rocket engines. Model rocketry is a popular hobby of the space age, and to launch a rocket, an engine is required. Estes, a subsidiary of Damon, is the leading manufacturer of model rockets and rocket engines. Their most powerful engine, the "D" engine, can develop almost 12 lbs. of thrust; enough to send a relatively large explosive charge a significant distance. Other companies, such as Centuri, produce even larger rocket engines, which develop up to 30 lbs. of thrust. These model rocket engines are quite reliable, and are designed to be fired electrically. Most model rocket engines have three basic sections. The diagram below will help explain them.

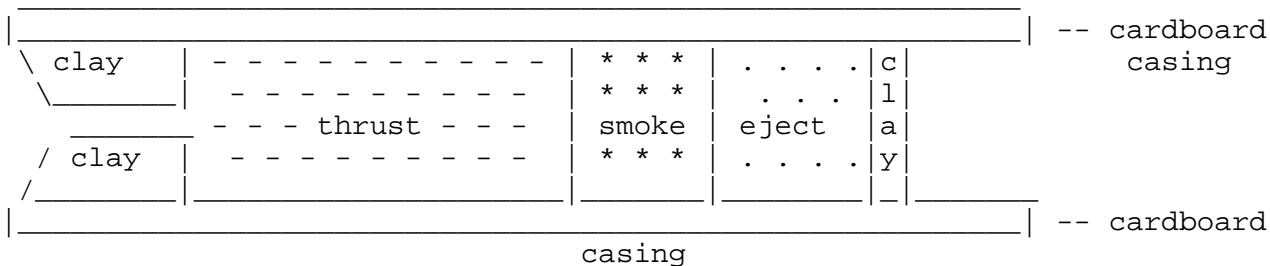

The clay nozzle is where the igniter is inserted. When the area labeled "thrust" is ignited, the "thrust" material, usually a large single grain of a propellant such as black powder or pyrodex, burns, forcing large volumes of hot, rapidly expanding gasses out the narrow nozzle, pushing the rocket forward.

After the material has been consumed, the smoke section of the engine is ignited. It is usually a slow-burning material, similar to black powder that has had various compounds added to it to produce visible smoke, usually black, white, or yellow in color. This section exists so that the rocket will be seen when it reaches its maximum altitude, or apogee.

When it is burned up, it ignites the ejection charge, labeled "eject". The ejection charge is finely powdered black powder. It burns very rapidly, exploding, in effect. The explosion of the ejection charge pushes out the parachute of the model rocket. It could also be used to ignite the fuse of a bomb...

Rocket engines have their own peculiar labeling system. Typical engine labels are: 1/4A-2T, 1/2A-3T, A8-3, B6-4, C6-7, and D12-5. The letter is an indicator of the power of an engine. "B" engines are twice as powerful as "A" engines, and "C" engines are twice as powerful as "B" engines, and so on. The number following the letter is the approximate thrust of the engine, in pounds. the final number and letter is the time delay, from the time that the thrust period of engine burn ends until the ejection charge fires; "3T" indicates a 3 second delay.

NOTE: an extremely effective rocket propellant can be made by mixing aluminum dust with ammonium perchlorate and a very small amount of iron oxide. The mixture is bound together by an epoxy.

## 6.11 BASIC ROCKET BOMB

A rocket bomb is simply what the name implies: a bomb that is delivered to its target by means of a rocket. Most people who would make such a device would use a model rocket engine to power the device. By cutting fins from balsa wood and gluing them to a large rocket engine, such as the Estes "C" engine, a basic rocket could be constructed. Then, by attaching a "crater maker", or CO2 cartridge bomb to the rocket, a bomb would be added. To insure that the fuse of the "crater maker" (see sect. 4.42) ignited, the clay over the ejection charge of the engine should be scraped off with a plastic tool. The fuse of the bomb should be touching the ejection charge, as shown below.

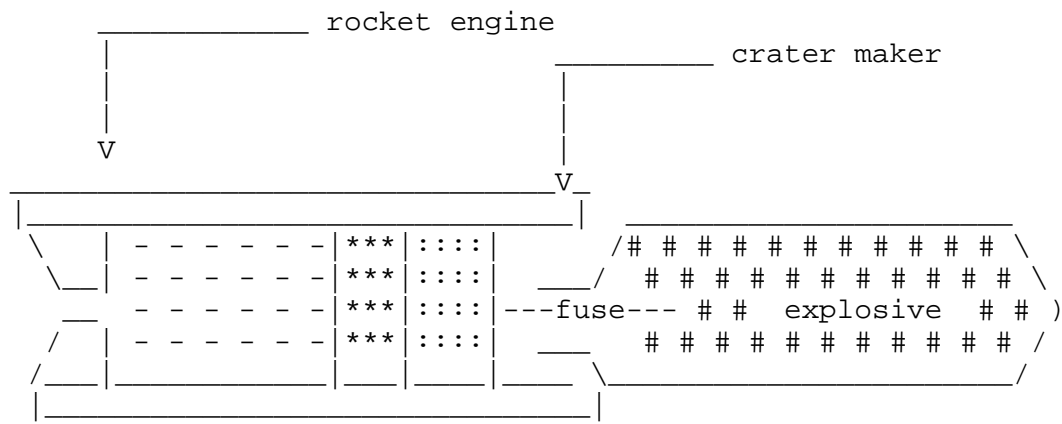

```

thrust> - - - - -
smoke>  ***
ejection charge> ::::
    
```

Duct tape is the best way to attach the crater maker to the rocket engine. Note in the diagram the absence of the clay over the ejection charge. Many different types of explosive payloads can be attached to the rocket, such as a high explosive, an incendiary device, or a chemical fire bottle.

Either four or three fins must be glued to the rocket engine to insure that the rocket flies straight. The fins should look like the following diagram:

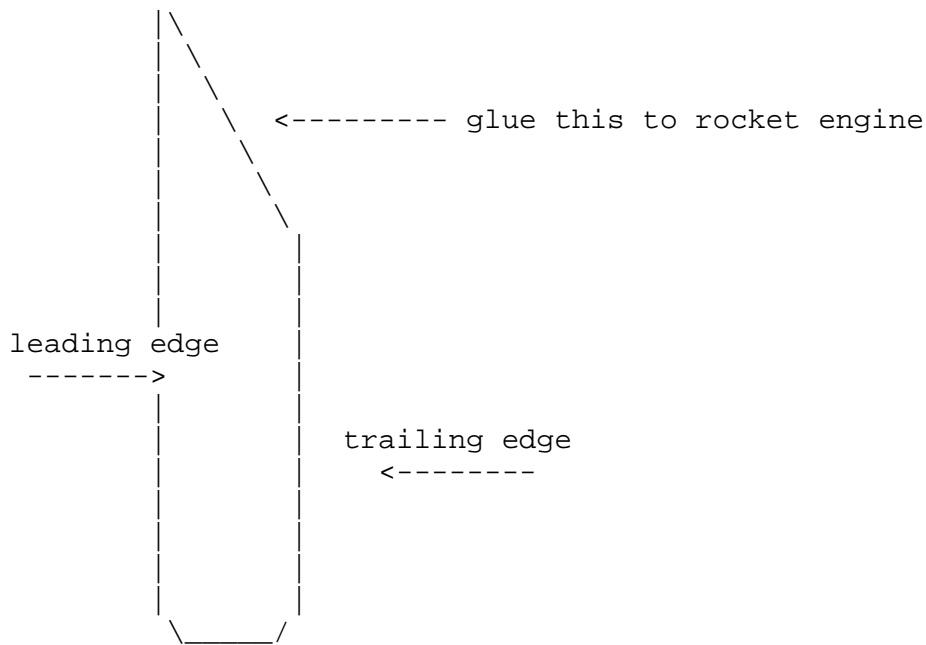

The leading edge and trailing edge should be sanded with sandpaper so that they are rounded. This will help make the rocket fly straight. A two inch long section of a plastic straw can be attached to the rocket to launch it from. A clothes hanger can be cut and made into a launch rod. The segment of a plastic straw should be glued to the rocket engine adjacent to one of the fins of the rocket. A front view of a completed rocket bomb is shown below.

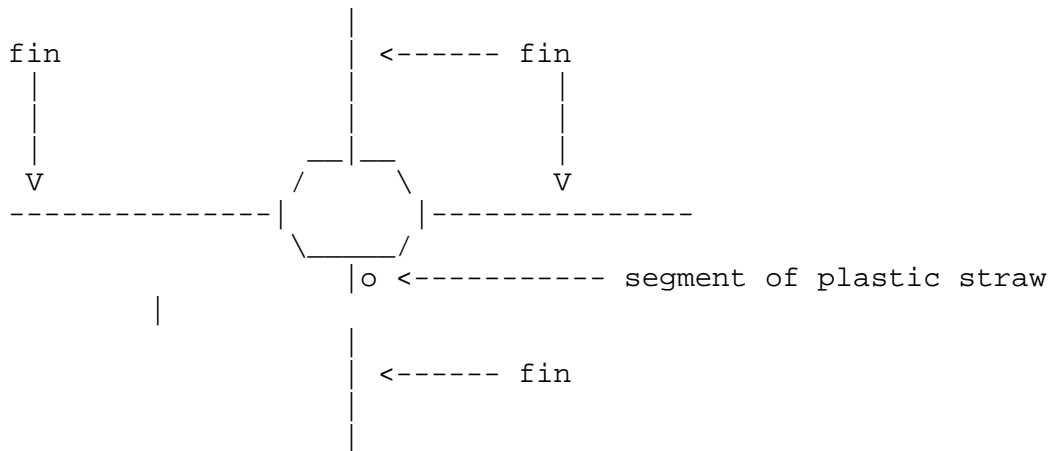

By cutting a coat hanger at the indicated arrows, and bending it, a launch rod can be made. After a fuse is inserted in the engine, the rocket is simply slid down the launch rod, which is put through the segment of plastic straw. The rocket should slide easily along a coathanger, such as the one illustrated on the following page:

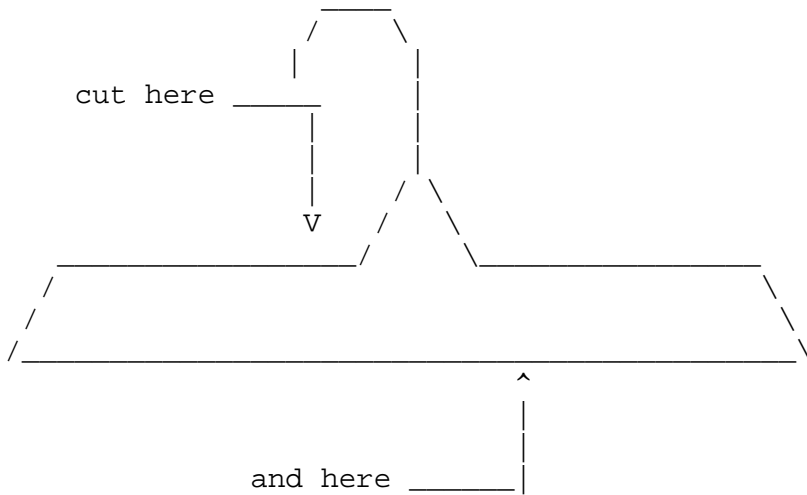

Bend wire to this shape:

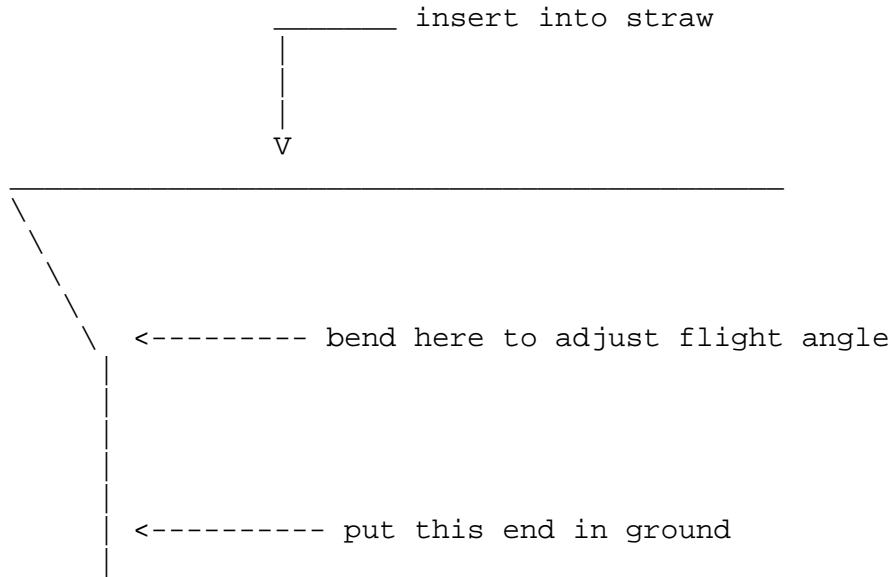

## 6.12 LONG RANGE ROCKET BOMB

Long range rockets can be made by using multi-stage rockets. Model rocket engines with an "0" for a time delay are designed for use in multi-stage rockets. An engine such as the D12-0 is an excellent example of such an engine. Immediately after the thrust period is over, the ejection charge explodes. If another engine is placed directly against the back of an "0" engine, the explosion of the ejection charge will send hot gasses and burning particles into the nozzle of the engine above it, and ignite the thrust section. This will push the used "0" engine off of the rocket, causing an overall loss of weight.

The main advantage of a multi-stage rocket is that it loses weight as travels, and it gains velocity. A multi-stage rocket must be designed somewhat differently than a single stage rocket, since, in order for a rocket to fly straight, its center of gravity must be ahead of its center of drag. This is accomplished by adding weight to the front of the rocket, or by moving the center of drag back by putting fins on the rocket that are well behind the rocket. A diagram of a multi-stage rocket appears on the following page:

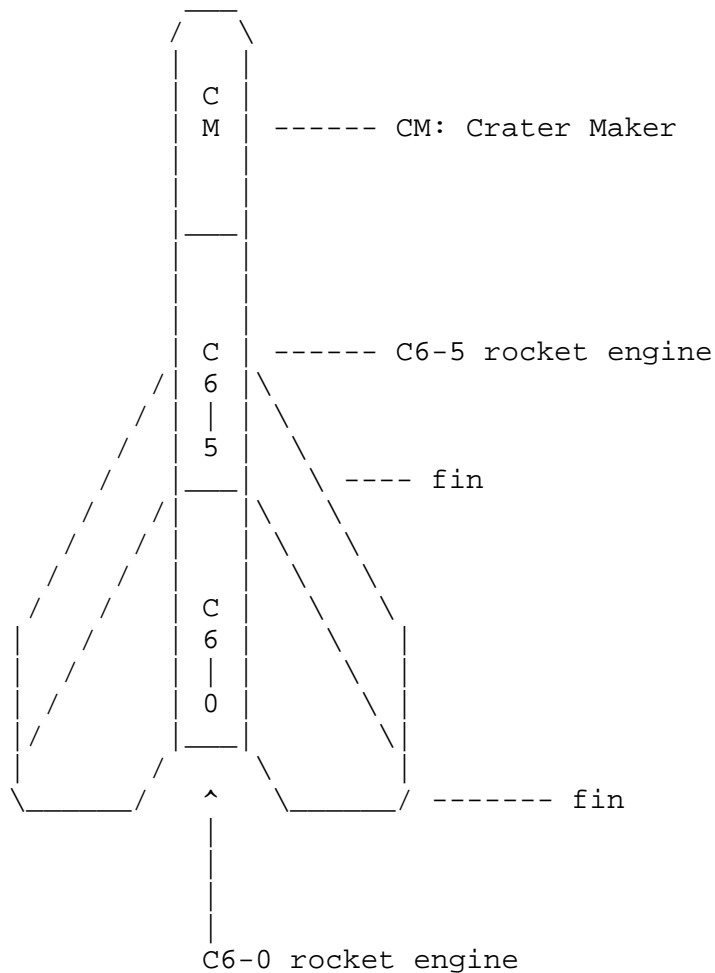

The fuse is put in the bottom engine.

Two, three, or even four stages can be added to a rocket bomb to give it a longer range. It is important, however, that for each additional stage, the fin area gets larger.

### 6.13 MULTIPLE WARHEAD ROCKET BOMBS

"M.R.V." is an acronym for Multiple Reentry Vehicle. The concept is simple: put more than one explosive warhead on a single missile. This can be done without too much difficulty by anyone who knows how to make crater-makers and can buy rocket engines. By attaching crater makers with long fuses to a rocket, it is possible that a single rocket could deliver several explosive devices to a target. Such a rocket might look like the diagram on the following page:

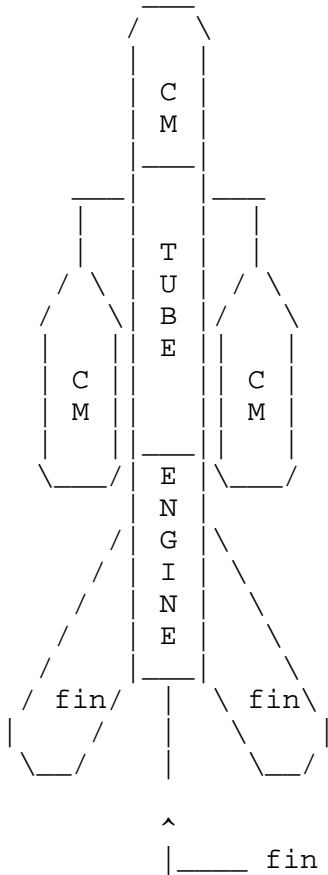

The crater makers are attached to the tube of rolled paper with tape. the paper tube is made by rolling and gluing a 4 inch by 8 inch piece of paper. The tube is glued to the engine, and is filled with gunpowder or black powder. Small holes are punched in it, and the fuses of the crater makers are inserted in these holes. A crater maker is glued to the open end of the tube, so that its fuse is inside the tube. A fuse is inserted in the engine, or in the bottom engine if the rocket bomb is multi stage, and the rocket is launched from the coathanger launcher, if a segment of a plastic straw has been attached to it.

## 6.2 CANNON

The cannon is a piece of artillery that has been in use since the 11th century. It is not unlike a musket, in that it is filled with powder, loaded, and fired. Cannons of this sort must also be cleaned after each shot, otherwise, the projectile may jam in the barrel when it is fired, causing the barrel to explode. A sociopath could build a cannon without too much trouble, if he/she had a little bit of money, and some patience.

### 6.21 BASIC PIPE CANNON

A simple cannon can be made from a thick pipe by almost anyone. The only difficult part is finding a pipe that is extremely smooth on its interior. This is absolutely necessary; otherwise, the projectile may jam. Copper or aluminum piping is usually smooth enough, but it must also be extremely thick to withstand the pressure developed by the expanding hot gasses in a cannon.



## 6.22 ROCKET FIRING CANNON

/-----\  
 | C |  
M
E
N
G
I
N
E
-----

A rocket firing cannon can be made exactly like a normal cannon; the only difference is the ammunition. A rocket fired from a cannon will fly further than a rocket alone, since the action of shooting it overcomes the initial inertia. A rocket that is launched when it is moving will go further than one that is launched when it is stationary. Such a rocket would resemble a normal rocket bomb, except it would have no fins. It would look like the image to the left.

the fuse on such a device would, obviously, be short, but it would not be ignited until the rocket's ejection charge exploded. Thus, the delay before the ejection charge, in effect, becomes the delay before the bomb explodes. Note that no fuse need be put in the rocket; the burning powder in the cannon will ignite it, and simultaneously push the rocket out of the cannon at a high velocity.

## 7.0 PYROTECHNICA ERRATA

There are many other types of pyrotechnics that a perpetrator of violence might employ. Smoke bombs can be purchased in magic stores, and large military smoke bombs can be bought through ads in gun and military magazines. Also, fireworks can also be used as weapons of terror. A large aerial display rocket would cause many injuries if it were to be fired so that it landed on the ground near a crowd of people. Even the "harmless" pull-string fireworks, which consists of a sort of firecracker that explodes when the strings running through it are pulled, could be placed inside a large charge of a sensitive high explosive. Tear gas is another material that might well be useful to the sociopath, and such a material could be instantly disseminated over a large crowd by means of a rocket-bomb, with nasty effects.

## 7.1 SMOKE BOMBS

One type of pyrotechnic device that might be employed by a terrorist in many ways would be a smoke bomb. Such a device could conceal the getaway route, or cause a diversion, or simply provide cover. Such a device, were it to produce enough smoke that smelled bad enough, could force the evacuation of a building, for example. Smoke bombs are not difficult to make. Although the military smoke bombs employ powdered white phosphorus or titanium compounds, such materials are usually unavailable to even the most well-equipped terrorist. Instead, he/she would have to make the smoke bomb for themselves.

Most homemade smoke bombs usually employ some type of base powder, such as black powder or pyrodex, to support combustion. The base material will burn well, and provide heat to cause the other materials in the device to burn, but not completely or cleanly. Table sugar, mixed with sulfur and a base material, produces large amounts of smoke. Sawdust, especially if it has a small amount of oil in it, and a base powder works well also. Other excellent smoke ingredients are small pieces of rubber, finely ground plastics, and many chemical mixtures. The material in road flares can be mixed with sugar and sulfur and a base powder produces much smoke. Most of the fuel-oxidizer mixtures, if the ratio is not correct, produce much smoke when added to a base powder. The list of possibilities goes on and on. The trick to a successful smoke bomb also lies in the container used. A plastic cylinder works well, and contributes to the smoke produced. The hole in the smoke bomb where the fuse enters must be large enough to allow the material to burn without causing an explosion. This is another plus for plastic containers, since they will melt and burn when the smoke material ignites, producing an opening large enough to prevent an explosion.

## 7.2 COLORED FLAMES

Colored flames can often be used as a signaling device for terrorists. by putting a ball of colored flame material in a rocket; the rocket, when the ejection charge fires, will send out a burning colored ball. The materials that produce the different colors of flames appear below.

COLOR	MATERIAL	USED IN
red	strontium salts (strontium nitrate)	road flares, red sparklers
green	barium salts (barium nitrate)	green sparklers
yellow	sodium salts (sodium nitrate)	gold sparklers
blue	powdered copper old pennies	blue sparklers,
white	powdered magnesium or aluminum	firestarters, aluminum foil
purple	potassium permanganate	purple fountains, treating sewage

## 7.3 TEAR GAS

A terrorist who could make tear gas or some similar compound could use it with ease against a large number of people. Tear gas is fairly complicated to make, however, and this prevents such individuals from being able to utilize its great potential for harm. One method for its preparation is shown below.

#### EQUIPMENT FOR MAKING TEAR GAS

---

- |                             |                      |
|-----------------------------|----------------------|
| 1. ring stands (2)          | 7. clamp holder      |
| 2. alcohol burner           | 8. condenser         |
| 3. erlenmeyer flask, 300 ml | 9. rubber tubing     |
| 4. clamps (2)               | 10. collecting flask |
| 5. rubber stopper           | 11. air trap         |
| 6. glass tubing             | 12. beaker, 300 ml   |

#### MATERIALS

---

10 gms glycerine    2 gms sodium bisulfate    distilled water

- 1.) In an open area, wearing a gas mask, mix 10 gms of glycerine with 2 gms of sodium bisulfate in the 300 ml erlenmeyer flask.
- 2.) Light the alcohol burner, and gently heat the flask.
- 3.) The mixture will begin to bubble and froth; these bubbles are tear gas.
- 4.) When the mixture being heated ceases to froth and generate gas, or a brown residue becomes visible in the tube, the reaction is complete. Remove the heat source, and dispose of the heated mixture, as it is corrosive.
- 5.) The material that condenses in the condenser and drips into the collecting flask is tear gas. It must be capped tightly, and stored in a safe place.

## 7.4 FIREWORKS

While fireworks cannot really be used as an effective means of terror, they do have some value as distractions or incendiaries. There are several basic types of fireworks that can be made in the home, whether for fun, profit, or nasty uses.

### 7.41 FIRECRACKERS

A simple firecracker can be made from cardboard tubing and epoxy. The instructions are below:

- 1) Cut a small piece of cardboard tubing from the tube you are using. "Small" means anything less than 4 times the diameter of the tube.
- 2) Set the section of tubing down on a piece of wax paper, and fill it with epoxy and the drying agent to a height of 3/4 the diameter of the tubing. Allow the epoxy to dry to maximum hardness, as specified on the package.
- 3) When it is dry, put a small hole in the middle of the tube, and insert a desired length of fuse.
- 4) Fill the tube with any type of flame-sensitive explosive. Flash powder, pyrodex, black powder, potassium picrate, lead azide, nitrocellulose, or any of the fast burning fuel-oxidizer mixtures will do nicely. Fill the tube almost to the top.
- 5) Pack the explosive tightly in the tube with a wad of tissue paper and a pencil or other suitable ramrod. Be sure to leave enough space for more epoxy.
- 6) Fill the remainder of the tube with the epoxy and hardener, and allow it to dry.
- 7) For those who wish to make spectacular firecrackers, always use flash powder, mixed with a small amount of other material for colors. By crushing the material on a sparkler, and adding it to the flash powder, the explosion will be the same color as the sparkler. By adding small chunks of sparkler material, the device will throw out colored burning sparks, of the same color as the sparkler. By adding powdered iron, orange sparks will be produced. White sparks can be produced from magnesium shavings, or from small, LIGHTLY crumpled balls of aluminum foil.

Example: Suppose I wish to make a firecracker that will explode with a red flash, and throw out white sparks.

First, I would take a road flare, and finely powder the material inside it. Or, I could take a red sparkler, and finely powder it.

Then, I would mix a small amount of this material with the flash powder. (NOTE: FLASH POWDER MAY REACT WITH SOME MATERIALS THAT IT IS MIXED WITH, AND EXPLODE SPONTANEOUSLY!) I would mix it in a ratio of 9 parts flash powder to 1 part of flare or sparkler material, and add about 15 small balls of aluminum foil I would store the material in a plastic bag overnight outside of the house, to make sure that the stuff doesn't react. Then, in the morning, I would test a small amount of it, and if it was satisfactory, I would put it in the firecracker.

8) If this type of firecracker is mounted on a rocket engine, professional to semi-professional displays can be produced.

#### 7.42 SKYROCKETS

An impressive home made skyrocket can easily be made in the home from model rocket engines. Estes engines are recommended.

1) Buy an Estes Model Rocket Engine of the desired size, remembering that the power doubles with each letter. (See sect. 6.1 for details)

2) Either buy a section of body tube for model rockets that exactly fits the engine, or make a tube from several thicknesses of paper and glue.

3) Scrape out the clay backing on the back of the engine, so that the powder is exposed. Glue the tube to the engine, so that the tube covers at least half the engine. Pour a small charge of flash powder in the tube, about 1/2 an inch.

4) By adding materials as detailed in the section on firecrackers, various types of effects can be produced.

5) By putting Jumping Jacks or bottle rockets without the stick in the tube, spectacular displays with moving fireballs or M.R.V.'s can be produced.

6) Finally, by mounting many home made firecrackers on the tube with the fuses in the tube, multiple colored bursts can be made.

## 7.43 ROMAN CANDLES

Roman candles are impressive to watch. They are relatively difficult to make, compared to the other types of home-made fireworks, but they are well worth the trouble.

1) Buy a 1/2 inch thick model rocket body tube, and reinforce it with several layers of paper and/or masking tape. This must be done to prevent the tube from exploding. Cut the tube into about 10 inch lengths.

2) Put the tube on a sheet of wax paper, and seal one end with epoxy and the drying agent. About 1/2 of an inch is sufficient.

3) Put a hole in the tube just above the bottom layer of epoxy, and insert a desired length of water proof fuse. Make sure that the fuse fits tightly.

4) Pour about 1 inch of pyrodex or gunpowder down the open end of the tube.

5) Make a ball by powdering about two 6 inch sparklers of the desired color. Mix this powder with a small amount of flash powder and a small amount of pyrodex, to have a final ratio (by volume) of 60% sparkler material / 20% flash powder / 20% pyrodex. After mixing the powders well, add water, one drop at a time, and mixing continuously, until a damp paste is formed.

This paste should be moldable by hand, and should retain its shape when left alone. Make a ball out of the paste that just fits into the tube. Allow the ball to dry.

6) When it is dry, drop the ball down the tube. It should slide down fairly easily. Put a small wad of tissue paper in the tube, and pack it gently against the ball with a pencil.

7) When ready to use, put the candle in a hole in the ground, pointed in a safe direction, light the fuse, and run. If the device works, a colored fireball should shoot out of the tube to a height of about 30 feet. This height can be increased by adding a slightly larger powder charge in step 4, or by using a slightly longer tube.

8) If the ball does not ignite, add slightly more pyrodex in step 5.

9) The balls made for roman candles also function very well in rockets, producing an effect of falling colored fireballs.

8.0 LISTS OF SUPPLIERS AND MORE INFORMATION

Most, if not all, of the information in this publication can be obtained through a public or university library. There are also many publications that are put out by people who want to make money by telling other people how to make explosives at home. Adds for such appear frequently in paramilitary magazines and newspapers. This list is presented to show the large number of places that information and materials can be purchased from. It also includes fireworks companies and the like.

COMPANY NAME AND ADDRESS	WHAT COMPANY SELLS
AAAAAAAAAAAAAAAAAAAAAAAAAA FULL AUTO CO. INC. P.O. BOX 1881 MURFREESBORO, TN 37133	AAAAAAAAAAAAAAAAAAAAAAAAAA EXPLOSIVE RECIPES, PAPER TUBING
UNLIMITED BOX 1378-SN HERMISTON, OREGON 97838	CHEMICALS AND FUSE
AMERICAN FIREWORKS NEWS SR BOX 30 DINGMAN'S FERRY, PENNSYLVANIA 18328	FIREWORKS NEWS MAGAZINE WITH SOURCES AND TECHNIQUES
BARNETT INTERNATIONAL INC. 125 RUNNELS STREET P.O. BOX 226 PORT HURON, MICHIGAN 48060	BOWS, CROSSBOWS, ARCHERY MATERIALS, AIR RIFLES
CROSSMAN AIR GUNS P.O. BOX 22927 ROCHESTER, NEW YORK 14692	AIR GUNS
R. ALLEN P.O. BOX 146 WILLOW GROVE, PA 19090	PROFESSIONAL FIREWORKS CONSTRUCTION BOOKS & FORMULAS
MJ DISTRIBUTING P.O. BOX 10585 YAKIMA, WA 98909	FIREWORKS FORMULAS
EXECUTIVE PROTECTION PRODUCTS INC. 316 CALIFORNIA AVE. RENO, NEVADA 89509	TEAR GAS GRENADES, PROTECTION DEVICES

COMPANY NAME AND ADDRESS	WHAT COMPANY SELLS
AAAAAAAAAAAAAAAAAAAAAAAAAAAA	AAAAAAAAAAAAAAAAAAAAAAAAAAAA
BADGER FIREWORKS CO. INC.	CLASS "B" AND "C" FIREWORKS
JANESVILLE, WISCONSIN	BOX 1451
53547	

NEW ENGLAND FIREWORKS CO. INC.	CLASS "C" FIREWORKS
STAMFORD, CONNECTICUTT	P.O. BOX 3504
06095	

RAINBOW TRAIL	CLASS "C" FIREWORKS
EDGEMONT, PENNSYLVANIA 19028	BOX 581

STONINGTON FIREWORKS INC.	CLASS "C" AND "B" FIREWORKS
WILSEY BAY U.25 ROAD	4010 NEW
RAPID RIVER, MICHIGAN 49878	

WINDY CITY FIREWORKS INC.	CLASS "C" AND "B" FIREWORKS
P.O. BOX 11	(GOOD PRICES!)
ROCHESTER, INDIANA 46975	

BOOKS  
AAAAA

THE ANARCHIST'S COOKBOOK

THE IMPROVISED MUNITIONS MANUAL

MILITARY EXPLOSIVES

FIRES AND EXPLOSIONS

## 9.0 CHECKLIST FOR RAIDS ON LABS

In the end, the serious terrorist would probably realize that if he/she wishes to make a truly useful explosive, he or she will have to steal the chemicals to make the explosive from a lab. A list of such chemicals in order of priority would probably resemble the following:

## LIQUIDS

\_\_\_\_\_

\_\_\_\_ Nitric Acid  
 \_\_\_\_ Sulfuric Acid  
 \_\_\_\_ 95% Ethanol  
 \_\_\_\_ Toluene  
 \_\_\_\_ Perchloric Acid  
 \_\_\_\_ Hydrochloric Acid

## GASES

\_\_\_\_\_

\_\_\_\_ Hydrogen  
 \_\_\_\_ Oxygen  
 \_\_\_\_ Chlorine  
 \_\_\_\_ Carbon Dioxide

## SOLIDS

\_\_\_\_\_

\_\_\_\_ Potassium Perchlorate  
 \_\_\_\_ Potassium Chlorate  
 \_\_\_\_ Picric Acid (usually a powder)  
 \_\_\_\_ Ammonium Nitrate  
 \_\_\_\_ Powdered Magnesium  
 \_\_\_\_ Powdered Aluminum  
 \_\_\_\_ Potassium Permanganate  
 \_\_\_\_ Sulfur (flowers of)  
 \_\_\_\_ Mercury  
 \_\_\_\_ Potassium Nitrate  
 \_\_\_\_ Potassium Hydroxide  
 \_\_\_\_ Phosphorus  
 \_\_\_\_ Sodium Azide  
 \_\_\_\_ Lead Acetate  
 \_\_\_\_ Barium Nitrate

## 10.0 USEFUL PYROCHEMISTRY

In general, it is possible to make many chemicals from just a few basic ones. A list of useful chemical reactions is presented. It assumes knowledge of general chemistry; any individual who does not understand the following reactions would merely have to read the first five chapters of a high school chemistry book.

1. potassium perchlorate from perchloric acid and potassium hydroxide

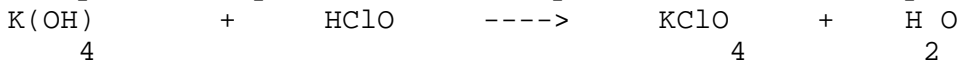

2. potassium nitrate from nitric acid and potassium hydroxide

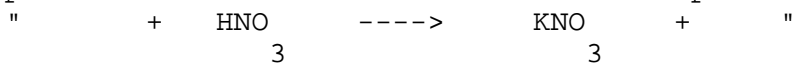

3. ammonium perchlorate from perchloric acid and ammonium hydroxide

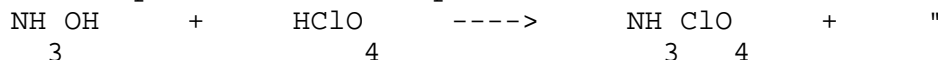

4. ammonium nitrate from nitric acid and ammonium hydroxide

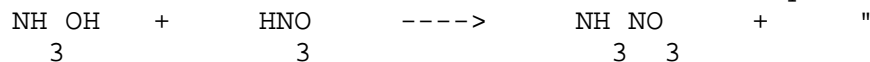

5. powdered aluminum from acids, aluminum foil, and magnesium

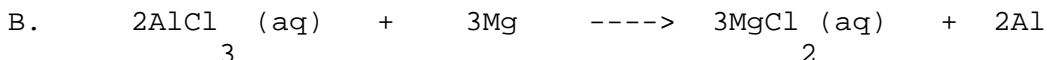
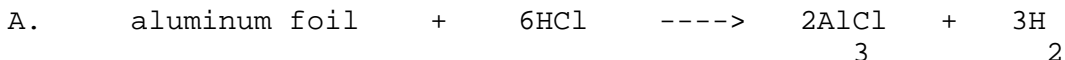

The Al will be a very fine silvery powder at the bottom of the container which must be filtered and dried. This same method works with nitric and sulfuric acids, but these acids are too valuable in the production of high explosives to use for such a purpose, unless they are available in great excess.

## 11.0 ABOUT THE AUTHOR

The author, who wishes his name to be unknown, is presently attending a college in the United States of America, majoring in Engineering. He was raised by his parents on the East Coast, and received his high school education there. He first became interested in pyrotechnics when he was about eight years of age. At age twelve, he produced his first explosive device; it was slightly more powerful than a large firecracker. He continued to produce explosive devices for several years. He also became interested in model rocketry, and has built several rockets from kits, and designed his own rockets.

While in high school, the author became affiliated with CHAOS, and eventually became the head of Gunzenbomz Pyro-Technologies. At this time, at age 18, he produced his first high explosive device, putting a 1 foot deep crater in an associate's back yard. He had also produced many types of rockets, explosive ammunition, and other pyrotechnic devices.

While he was heading Gunzenbomz Pyro-Technologies, he was injured when a home made device exploded in his hand; he did not make the device. The author learned, however, and then decided to reform, and although he still constructs an occasional explosive device, he chooses to abstain from their production.

An occasional rocket that produces effects similar to that of professional displays can sometimes be seen in the midnight sky near his college, and the Fourth of July is still his favorite day of the year.

Pax et Discordia,

the Author

END OF PART 1 OF THE COMPLEAT TERRORIST

PART 2 - Tennis ball cannons

----- Information from the Usenet. The Usenet is a worldwide network of 15,000 machines and over 500,000 people- And growing!

Addendum by David Richards:

The POINT BBS at (312) 338-0632 offers free access to several usenet message areas.

Addendum by The Editor: If you aren't in the Chicago area, check a local BBS list. If you see a BBS which runs under UNIX, odds are it carries usenet. The appropriate place to look is rec.pyrotechnics.

At this time (twelve years ago) most soft drink cans were rolled tin rather than the molded aluminum. We would cut the tops and bottoms off of a bunch of them and tape them together with duct tape, forming a tube of two feet or more.

At the end we would tape a can with the bottom intact, more holes punched (with a can opener) around the top, and a small hole in the side at the base. We then fastened this contraption to a tripod so we could aim it reliably. Any object that came somewhat close to filling the tube was then placed therein.

In the shop, we used the clock as a target and an empty plastic solder spool as ammunition, with tape over the ends of the center hole and sometimes filled with washers for weight. When taken to parties or picnics, we would use whatever was handy. Hot dog rolls or napkins filled with potato chips provided spectacular entertainment.

Once loaded, a small amount of lighter fluid was poured into the hole in the side of the end can and allowed to vaporize for a few moments. The "fire control technician" would announce "Fire in the Hole" and ignite it.

BOOM! Whoosh! The clock never worked after that!

-----

Our version of the potatoe chip cannon, was built similarly. Ours used coke cans, six with the top and bottom removed, and the seventh had church key holes all around one end. This was spiral wrapped with at least two rolls of duct tape.

A wooden shoulder rest and forward hand grip was taped to the tube. For ignition we used lantern batteries to a model-t coil, actuated by a push button on the hand grip. A fresh wilson tennis ball was stuffed all the way back to the grid, and a drop or two of lighter fluid was dropped in one of two holes in the end. The ignition wire was poked through the other hole.

We would then lie in ambush, waiting for something to move. When fired with the proper air/fuel mixture, a satisfying thoomp! At maximum range the ball would travel about 100 yards with a 45 degree launch angle. Closer up the ball would leave a welt on an warring opponent. When launched at a moving car the thud as it hit the door would generally rattle anyone inside. Luckily we never completed the one that shot golf balls.

PART 3 - Fun with dry ice. LOTS of fun with dry ice. Also from the Usenet.

Editor's Note: Dry ice can be a lot of fun, but be forewarned:

Using anything but plastic to contain dry ice bombs is suicidal. Dry ice is more dangerous than TNT, because it's extremely unpredictable. Even a

2-liter bottle can produce some nasty shrapnel: One source tells me that he caused an explosion with a 2-liter bottle that destroyed a metal garbage can. In addition, several kids have been killed by shards of glass resulting from the use of a glass bottle. As a result, dry ice bombs have been classified as infernal devices, and possession is a criminal offense.

> ... if you fill a pot with boiling water, then add some dishsoap, and then  
> drop in a large chunk of dry ice, you get a large number of bubbles VERY  
> quickly. We're talking terabubbles. Do this outside or you will be sorry.

>Has anyone ever thrown dry ice into a public pool? As long as you chuck it  
>into the bottom of the deep end, it's safe, and it's really impressive if the  
>water is warm enuff

## DRY ICE

### Time Bombs:

1. Get a small plastic container with lid (we used the small plastic cans that hold the coaters used for large-format Polaroid film). A film canister would probably work; the key is, it should seal tightly and take a fair amount of effort to open).

Place a chunk of dry ice in the can, put on the lid without quite sealing it. Put the assembled bomb in your pocket, or behind your back.

Approach the mark and engage in normal conversation. When his attention is drawn away, quickly seal the lid on the bomb, deposit it somewhere within a few feet of the mark, out of obvious sight, then leave.

Depending on variables (you'll want to experiment first), you'll hear a loud "pop" and an even louder "Aarrggghh!" within a minute, when the CO2 pressure becomes sufficient to blow off the lid.

In a cluttered lab, this is doubly nasty because the mark will probably never figure out what made the noise.

2. Put 2-3 inches of water in a 2-liter plastic pop bottle. Put in as many chunks of dry ice as possible before the smoke gets too thick. Screw on the cap, place in an appropriate area, and run like hell. After about a minute (your mileage may vary), a huge explosion will result, spraying water everywhere, along with what's left of the 2-liter bottle.

### More things to do with Dry Ice:

"I put it in my teacher's coffee. (Holy sh-t, the place is on fire!)"

"Throw it in toilets. (Creature from the Brown Lagoon)"

"Make soda from ordinary juice, etc."

"Blow up balloons and condoms with it (Put a chunk in a balloon, tie up the end.)"

"Fun stuff. It SCREAMS when it comes into contact with metal..." "You can safely hold a small piece of dry ice in your mouth if you KEEP IT MOVING CONSTANTLY. It looks like you're smoking or on fire." Fluorescein (the stuff in navy-surplus sea dye markers) is effective in swimming pools. Or try a "Baby Ruth" candy bar...

Addendum by Vlad Tepes 7-29-91

\*\*\*\*

There is no standard formula for a dry ice bomb, however a generic form is

as follows:

Take a 2-liter soda bottle, empty it completely, then add about 3/4 Lb of Dry Ice (crushed works best) and (optional) a quantity of water.

Depending on the condition of the bottle, the weather, and the amount and temperature of the bottle the bomb will go off in 30 seconds - 5 minutes.

The explosion sounds equivalent to an M-100. \_Plastic\_ 16 oz. soda bottles and 1 liter bottles work almost as well as do the 2-liters, however glass bottles aren't nearly as loud, and can produce dangerous shrapnel.

Without any water added, the 2-liter bottles will go often in 3-7 minutes if dropped into a warm river, and in 45 minutes to 1 1/2 hours in open air.

Remember, these are LOUD! Dorian, a classmate of mine, set up 10 bottles in a nearby park without adding water. After the first two went off (there was about 10 minutes between explosions) the Police arrived and spent the next hour trying to find the guy who they thought was setting off M-100's all around them...

\*\*\*\*

#### PART 4

##### More Fun Stuff for Terrorists

##### Carbide Bomb

This is EXTREMELY DANGEROUS. Exercise extreme caution.... Obtain some calcium carbide. This is the stuff that is used in carbide lamps and can be found at nearly any hardware store.

Take a few pieces of this stuff (it looks like gravel) and put it in a glass jar with some water. Put a lid on tightly. The carbide will react with the water to produce acetylene carbonate which is similar to the gas used in cutting torches.

Eventually the glass will explode from internal pressure. If you leave a burning rag nearby, you will get a nice fireball!

##### Portable Grenade Launcher

If you have a bow, this one is for you. Remove the ferrule from an aluminum arrow, and fill the arrow with black powder (I use grade FFFF, it burns easy) and then glue a shotshell primer into the hole left where the ferrule went. Next, glue a BB on the primer, and you are ready to go! Make sure no one is nearby.... Little shreds of aluminum go all over the place!!

##### Auto Exhaust Flame Thrower

For this one, all you need is a car, a sparkplug, ignition wire and a switch. Install the spark plug into the last four or five inches of the tailpipe by drilling a hole that the plug can screw into easily. Attach the wire (this is regular insulated wire) to one side of the switch and to the spark plug. The other side of the switch is attached to the positive terminal on the battery. With the car running, simply hit the switch and watch the flames fly!!! Again be careful that no one is behind you! I have seen some of these flames go 20 feet!!!

PART 5- This is all various files I gleaned from BBS's. (Added 8-23-90)

This works best if you happen to have a lot of derelict friends, as I do... Your first day of school you should bring the following items, to insure a prosperous school year:

- 1) Fountain pen (and extra ink refills)
- 2) 3 tubes of Super Glue (Krazy Glue)
- 3) Pennies (about \$1.00 worth)
- 4) Balloons (small sized for convenience)
- 5) Mirror (small hand held)
- 6) Liquid soap
- 7) Lighter, (matches as alternate)
- 8) Firecrackers (ladyfingers are great)
- 9) Screwdrivers and other tools (small)
- 10) Small squeezable bottles (like nasal de-congestant type)
- 11) Wire (10-20 ft)
- 12) Tape recorder mic. (batter operated pref.)
- 13) Ziplock baggies
- 14) Half of an orange
- 15) Light bulb (75 watts and over are great)

This will do for now... Some of the cool things to do are, take the pennies and glue them to the cafeteria tables, (and watch the custodians try to get 'em off). (this also looks good with silver dollars glued to the fire alarm (so it goes off when the custodian attempts to remove the coin) and to a door someplace... (principals preferably)

Another thing to do with a coin is, heat it up over a bunsen burner (in chem) and just as the bell rings, toss the coin into the hall, I will guarantee you will know when the coin is picked up... While you're using the bunsen burner, fill your little squeeze bottle with gas, then cap it tight and put it in your pocket... later, take a firecracker, and glue it to the bottle, use a cigarette as a fuse extension, then put it in the bathroom, and get to class fast... (gas and glue make a nice flame)...

While you're in the bathroom, place a light bulb over the door, and when the superintendent goes to see what the explosion was, he gets a nice little surprise...

Now for the wire, if you can access a room near your locker, when no one is in the room, take off the speaker cover on the PA system, and hook 2 wires from it, to your mic. ( then into your locker) This is good for get-ting your friends out of classes... Just ask for them... (use your tools for that one, and try to be neat about it)...

Now for your mirror, you can use this for getting your, uh... "Friend's" locker combination... after you get that, take that little baggie you got, and put the orange in it... let it sit for a week or four, then open the baggie, and place it in your friends locker... I can guarantee he/ she will love it...

Another thing that is fun to do, is, Take a penny, and glue it over the key hole on your friends gym locker, just after he goes out, thus he has to truck around all day in his gym stuff, (unless you rent him your screwdriver to pry the penny off)

Balloons are fun to play with in chem lab, fill them with the gas that you get out of the taps on the lab desks, then tie up the balloon tight, and drop it out the window to the burnouts below, you know, the ones that are always smoking, they love to pop balloons with lit cigarette.... get the picture? Good...

Those fountain pens are cool, because if you make a slight jerking motion with your hand, ink squirts all over the room, (or person, whatever you're aiming at) It is a good idea not to let the teachers know you have one of those, it makes it too easy to find out who did it when there's ink all over the principals face... (or on the floors, walls, and ceilings...)

Liquid soap is great for use in crowded hallways, it turns every-body into a ice skating star, (works especially well when people come in from the rain)... If your school is anything like the one I go to, people never flush the toilets, A little liquid soap in here makes for a nice surprise, I mean, what happens when the soap is not flushed out of the toilet, and the suds aren't flushed out either? The janitors have a really good time trying to figure out that one... (glue a quarter in one of the urinals, always fun)... Turn off the water under the sinks too. Getting back to the soap, it is also good on the hand railings in hall-ways and on steps, If you mix perfume with it, some poor grub has to have that stench on him all day.

- The Dark Side (312) - 787 - 2174 / Exilic Xyth - Sysop / 24 hours 9600  
The Modern Speeders Guide to Radar and State Troopers  
By : Exilic Xyth January 11, 1988

### Introduction:

Touched off by the discussion on Ripco <312>-528-5020, I found many users asking questions about police radar, radar detectors, and speeding. With Ron Majors talking about the oil spill that will appear in detail on the news at ten I thought a informative file on the subject might be beneficial. I myself had my first experience with police radar in my fathers car, then following in baseball and my own driving, much more on the subject. What a fascinating device, that it will return your speed instantly, what fun one would be to have! After a quick talk with a police friend of mine, I soon took possession of a used police radar gun.

### Part one: Operation.

Police Radar works via the doppler effect, best demonstrated by sound rather than microwaves. The doppler effect is the relation of speed to the pitch of 'sound'. Sometime, all of you must have had the distinct pleasure of being honked at by a motorist on the go, you might have noticed that the horn <an F flat on most american cars> begins with a higher pitch and as the car passes, drowns off to a lower tone. The sound waves at the front of the car are pressed together by the forward motion of the car, creating a higher pitch. As the car passes, the tone dies off to a lower pitch because the waves are spread out.

Police radar works in much the same way. The major differences are the frequency and the concentration of the carrier. As of 1988, the F.C.C. is rumored to have lifted restrictions on police radar frequencies. Before, only two frequencies were approved for police radar use. X-band <10.525 GHz> which is most commonly used, and K-band <24.15 Ghz>. I will assume for now, due to lack of any SOLID evidence supporting the restriction lift, that those are the only two in operation. Police radar 'beams' are similar in shape to a flashlight beam. They begin with a thin width and cone outwards with distance. Most guns operating at the X-band level have a range of about 2000 ft., although high power units can exceed 2500 and 3000ft., and K-band guns fall shorter at about 1200 ft.. At 1500ft., the radar beam becomes about the width of four highway lanes, so for practical purposes radars range is around 1700 ft..

A radar signal transmitted from the 'Radar Gun's' transmitter, (called the oscillator) will bounce off a object and return to the radar receiver (or antenna). If the object is moving, the frequency of the beam will be altered as it bounces. This is most easily visualized watching water ripples. Assume now that I have just dropped a pebble in a pond, and the ripples are moving outward, assume also for purposes of simplicity that the ripples are moving at 1 foot per second, and that they are one foot apart. The ripples are therefore also one second apart. Upon bouncing off a stationary object the ripples will return weakened, but at the same interval and speed <Not really the same speed, but let's not complicate things>.

Now let us assume that a toy boat is traveling in the water at .5 ft. per second, 1/2 the speed of the ripples, away from the point which I dropped the pebble. Assume the first ripple has hit the boat and is traveling back. The second ripple now traveling at 1 foot per second is only gaining on the boat by .5 feet per second <1 ft. per second - .5 ft. per second>. This means that the ripple is one foot away from the boat, as the ripples are one foot apart. The ripple will take 2 second to reach the boat, as the closure speed is .5 ft. per second and the distance is 1 foot. The ripple strikes the boat and bounces back two seconds after the first ripple. The process works inversely for an object moving towards the pebbles point of impact.

As the distance between the ripples can be determined by the speed, on the other side, the speed can be determined by the distance between the ripples. Police radar works in the same way with microwaves. The microwave signal bounces off a moving vehicle and returns altered in frequency. In this way the radar unit determines the speed of the object.

Radar is only accurate when the object is moving directly at, or directly away from the gun, although some modern guns will account for this 'COSINE error', most won't. Cosine error can be defined as this: When a radar signal bounces off an object at an angle from the objects direction of travel it will return a portion of the objects speed computed by the cosine of the infraction angle. If the angle of the objects direction and the radars direction is 20 degrees the speed returned by the radar is 93.97% of the objects actual speed.  $\cos(20) = .93969262 * \text{objects speed} = \text{returned speed}$ .

For example: A car is traveling at 75 m.p.h.. The state trooper, in his infinite wisdom, decides to "Clock" the automobile in hopes of meeting his quota for the month. Picking up his handy radar gun, he aims, and fires an invisible beam of microwave energy. The officer however, being the rookie he is, leaves a high angle between the cars direction and his beam of 45 degrees.  $\cos(45) = .707106781$   $.707106781 * 75\text{m.p.h.} = 53.03300859$  53 m.p.h. is displayed on the officers screen. Lucky motorist. Sorry 40 column users.

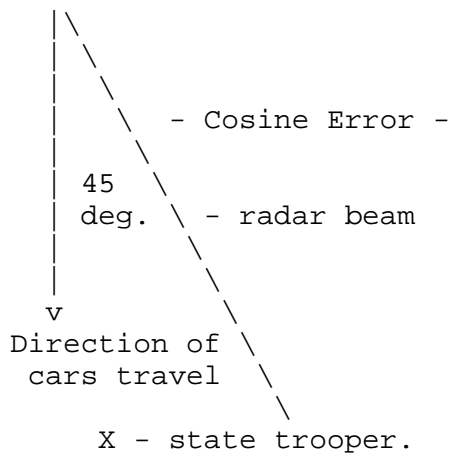

## Part 2: Application

In 1986, over 15 million speeding tickets were issued, and experts estimate that over 25% of them were in error. Police have been using radar for speed control for many years, and as the technology has become more complex and accurate, so has the ability to get away with the slight infractions of the speed limits set by the government become more difficult. In recent years, the three most damaging advances to motorists in radar technology include:

- A> Instant on radar.
- B> K-band radar.
- and C> Cosine error correcting radar units.

### Instant on radar.

With the increase of radar receivers, or "Detectors" on the roads, police have attempted to bypass the motorists first line of defense. The most damaging advance in the war against speeding motorists is instant on radar. The idea behind instant on radar is to make the radar detector useless to the motorist by making his warning too late to react to. Instant on radar was developed in early 1983, but never marketed until late 1984 when the michigan state troopers were equipped with the first instant on radar guns. It operates by deactivating the oscillator until triggered by the officer. When used properly and under the right traffic conditions, it is indefensible. It works like a camera, the officer operating the radar will position himself behind a blind corner or over a hill. When the approaching car crests the hill or rounds the corner, the officer will activate the oscillator, taking a "snapshot" of your car. As microwaves travel at the speed of light, any attempt at slowing down is futile, the officer behind the gun has your speed in less than a tenth of a second.

### K-band Radar.

When radar detectors were first marketed by the makers of ESCORT, there was only one type of radar. X-band. In an attempt to increase the dwindling speeding ticket revenue, K-band was brought to life. K-band is a different frequency that could not be picked up by the primitive detectors of the age. However, as the frequency got out, the detectors adapted, and now any detector worth a dollar will detect both X and K bands. K band is more dangerous as most K-band guns are instant on and they have less 'Splash' and range than X-band guns. This means that a K-band signal is probably closer to you.

### Cosine error correcting guns.

Cosine error was a major failing of radar in the judicial system, all readings were under question in court, the result was a gun which will correct for cosine error by determining the angle which the radar beam "impacts" with the car. Also new in correcting cosine error were guns with 'Speed lock on' in which the highest speed reading received by the gun is locked in and displayed.

Moving radar guns.

Until new developments, all radar units had to remain stationary as radar measures only closure speed, and not actual speed. Moving radar ended this trend. Moving radar works like this. First the radar gun determines the patrol cars speed by clocking a sign or fixed object. The closing speed of the patrol car to the sign is subtracted from the now taken closing speed to the target car.

Patrols speed - 60 m.p.h.

Closing speed to car - 120 m.p.h.

120 m.p.h. - 60 m.p.h. = 60 m.p.h..

### Part 3: Defense

From the dawn of speed enforcement, motorists have sought to defeat the laws, starting with detectors, continuing to jammers and topping out with the new 'CHiPs detectors' The unfortunate conditions now favor the police and law enforcement officials with the introduction of new radar technologies such as instant on radar.

#### Detectors:

The simple radar receiver is the first line of defense from radar. Varied in operation and features, the radar detectors of today are designed to provide high sensitivity and low rates of false alarms. Good detectors will measure signal strength and type <K or X> and have an effective range of about 3000 ft. and a probable range of well over a mile. Sensitivity tops out around 110.5 dBm/cm<sup>2</sup> for X band and 108 dBm/cm<sup>2</sup> for K band <Both set by the passport>. A detector can give you an excellent advantage over radar by alerting you it's there. Detectors become especially useful in Chicago where instant on radar is not typically used.

#### Jammers:

Radar jammers are essentially units that transmit microwaves at a frequency dictating a certain speed. The result is regardless of your speed, the police radar unit will display the speed you set the jammer to transmit. Jammers are highly illegal and will be confiscated if discovered, expect a stiff fine.

#### Chip's detector.

This is a new device, which is really a scanner on the police radio band. It takes advantage of a signal transmitted by the patrol cars in some states as part of their dispatch system. The signal carries for about three miles, and the Chip's Detector will alert you if you are within that range of a highway patrol unit. It also allows scanning of police radio channels.

#### Last words.

Radar is a basically accurate instrument, when used properly, it can be deadly. As I have said before instant on radar is impossible to avoid when there is no other traffic around, regardless of a detector. The only thing that comes close is a Radar Jammer, which will most likely not serve you well unless it is WELL hidden. Radar jammers are dangerous with the introduction of the HAWK, a radar unit by Kustom Signals, which DETECTS radar jammers in the hold mode.

Aside from radar, VASCAR <Visual average speed computer and recorder> is a new danger to motorists. It is basically a stopwatch used to time your movement between two point of which the interval distance is known. Using the formula Average velocity = distance / time, the state trooper can determine your speed without setting off your detector.

Instant on radar defense.

The only real defense for instant on radar is traffic. Traffic will cause the trooper to activate his radar gun more often, cluing you into his presence. A jammer well hidden will help, but the best technique is to follow a car making good time. Any police units in the area will clock him first, and legally they have to ticket him, unless you're too close.

Remember:

Do not speed, it is a dangerous practice, and I can not be responsible for any injury, or action due to this file, it is for informational purposes only. The state troopers enforce speed limits for your safety.

Radar guns: Models.

Radar guns are manufactured by many different companies, but the primary ones are Kustom Signals, M.p.h. Industries, and Decatur. The deadliest gun now available is the HAWK manufactured by Kustom Signals. It is the first gun capable of clocking cars moving the SAME direction as the patrol car. It has two antennas, one forward, and one back. Like I stated before, it is also the first gun capable of detecting radar jammers. These run about \$~2000

Kr-11

This gun is a two piece model which uses a weak pulse signal in the moving mode to determine the patrol car's speed while not triggering detectors. This gun permits a faster clocking time for instant on moving radar, it runs about \$~1200

Falcon

This is a hand held gun operating on K band Small and compact it is preferred among law enforcement radars. It runs about 600\$

Hr-4 Hr-8 Hr-12

400,500,750\$ respectively, these are hand held radar guns made by Kustom Signals

All these units are available to you via me for less than the troopers pay for them. For prices, and statistics, call my board at (312) - 787 - 2174 or send me mail at Ripco (312) 528-5020

Prices for radar units range from 250-2000\$

I personally enjoy harassing that 911 who barrels by at 95 with a detector.

## Picking combo locks:

Ok, so ya say ya wanna learn how to pick combination locks...This text file should help you. As a matter of fact, if ya do it right, it will help you.

First of all, let me tell you about the set-up of a lock. When the lock is locked, there is a curved piece of metal wedged inside the little notch on the horseshoe shaped bar that is pushed in to the lock when you lock it.

To free this wedge, you usually have to turn the lock to the desired combination and the pressure on the wedge is released therefore letting the lock open. I will now tell you how to make a pick so you can open a lock without having to waste all that time turning the combination (this also helps when ya don't know the combination to begin with).

First of all, ya need to find a hairpin. What's a hairpin? Well, just ask your mom. She will have one. If she asks what its for, say ya gotta hold something together... If she says use a rubberband or use a paperclip, go to the store and rip off a box of 50 or so.

Once you have your hair pin (make sure it's metal), take the ridged side and break it off right before it starts to make a U-turn onto the straight side. The curved part t can now be used as a handle. Now, using a file, file down the other end until it is fairly thin. You should do this to many hairpins and file them so they are of different thicknesses so you can pick various locks. Some locks are so cheap that ya don't even have ta file! But most are not.

Ok, now you have a lock pick. Now if ya haven't figured it out, here's how ya use it. You look at a lock to see which side the lock opens from. If you can't tell, you will just have to try both sides. When ya find out what side it opens from, , take the lock pick and stick the filed end into the inside of the horseshoe-shaped bar on whichever side the lock opens from.

Now, put pressure on the handle of the lock pick (pushing down, into the crack) and pull the lock up and down. The lock will then open because the pick separated the wedge and the notch allowing us thieves to open it. Don't say bullshit until you've tried it. Because I have gotten lots of beer money from doin' this to fellow students' gym lockers.

Also, this technique works best on American locks. I have never picked a Master lock before because of the shape a pressure of the wedge but if anyone does it, let me know how long it took. Also, the Master lock casing is very tight so ya can't get the pick in. So, if you're locking something valuable up, use a Master, cuz at least ya know I won't be picking it and I'm sure there aren't that many that could. And when I say pick, i don't mean lighting a stick of dynamite next to the lock, picking is opening a lock without using force, making a substitute key, etc...

If any of you believe that this information is not sufficient for picking an American lock, or any other kind besides Master, leave me a message at /\ \etallant 1 (503) 538-0761. This concludes my text file on picking combination locks. My next text file will probably be "Picking key locks". See ya later, The Byte basher.

How to pick MASTER locks By Gin Fizz & Ninja NYC

Have you ever tried to impress your friends by picking one of those Master combination locks and failed? Well then read on. The Master lock company has made this kind of lock with a protection scheme. If you pull the handle of it hard, the knob won't turn. That was their biggest mistake..... Ok, now on to it.

1st number. Get out any of the Master locks so you know what's going on. 1: The handle part (the part that springs open when you get the combination), pull on it, but not enough so that the knob won't move. 2: While pulling on it turn the knob to the left until it won't move any more. Then add 5 to this number. Congratulations, you now have the 1st number.

2nd number. (a lot tougher) Ok, spin the dial around a couple of times, then go to the 1st number you got, then turn it to the right, bypassing the 1st number once. WHEN you have bypassed. Start pulling the handle and turning it. It will eventually fall into the groove and lock. While in the groove pull on it and turn the knob. If it is loose go to the next groove; if it's stiff you got the second number.

3rd number: After getting the 2nd, spin the dial, then enter the 2 numbers, then after the 2nd, go to the right and at all the numbers pull on it. The lock will eventually open if you did it right. If can't do it the first time, be patient, it takes time.

Addendum 4/12/91: I've tried this, and it no longer seems to work (master wised up)

HOWEVER- the "MASTER warded padlock" locks are easily picked...

These are the lock with the keys that look like this:



Just file the key down so it looks like this:



Now you can bypass the wards... sometimes you have to pull the key up and down, turning as you pass each block, to release the latch.

\*End Addendum

## PYROTECHNICAL DELIGHTS

WRITTEN BY RAGNER ROCKER

Many of you out there probably have fantasies of revenge against teachers, principals and other people who are justassholes. depending on your level of hatred of this person i would advise that you do some of these following experiments:

(1) Pouring dishsoap into the gas tank of your enemy- many of you already know that gasoline + dishsoap(e.g. joy, palmolive, etc.) form a mixture called napalm. now napalm is a jelly-like substance used in bombs, flamethrowers, etc. now you can only guess what this mixture would do to someone's fuel line!!!!

(2) Spreading dirty motor oil/castor oil on someone's exhaust pipe- when the exhaust pipe heats up(and it will!!)the motor oil or castor oil on the pipe will cause thick, disgusting smoke to ooze forth from the back of that car. Who knows maybe he/she might be pulled over and given a ticket!!

(3) Light Bulb Bomb- see part one of the file

(4) Simple smoke/stink bomb- you can purchaase sulphur at a drugstore under the name flowers of sulphur. now when sulphur burns it will give off a very strong odor and plenty of smoke. now all you need is a fuse from a firecracker, a tin can, and the sulphur. fill the can with sulphur(pack very lightly), put aluninum foil over the top of the can, poke a small hole into the foil, insert the wick, and light it and get out of the room if you value your lungs. you can find many uses for this( or at least i hope so.

## FUN WITH ALARMS

A fact I forgot to mention in my previous alarm articles is that one can also use polyurethane foam in a can to silence horns and bells. you can purchase this at any hardware store as insulation. it is easier to handle and dries faster.

Many people that travel carry a pocket alarm with them. this alarm is a small device that is hung around the door knob, and when someone touches the knob his body capacitance sets off the alarm. these nasty nuisences can be found by walking down the halls of a hotel and touching all the door knobs very quickly. if you happen to chance upon one, attach a 3' length of wire or other metal object to the knob. this will cause the sleeping business pig inside to think someone is breaking in and call room service for help. all sorts of fun and games will ensue.

Some high-security instalations use keypads just like touch-tone pads (a registered trade mark of bell systems) to open locks or disarm alarms. most use three or four digits. to figure out the code, wipe the key-pad free from all fingerprints. after it had been used just apply finger print dust and all four digits will be marked. now all you have to do is figure out the order. if you want to have some fun with a keypad, try pressing the \* and # at the same time. many units use this as a panic button. This will bring the owner and the cops running and ever-one will have a good time. never try to remove them from the wall, as they all have tamper switches.

On the subject of holdups, most places (including super-markets, liquer stores, etc.) have what is known as a money clip. these little nasties are placed at the bottom of a money drawer and when the last few bills are with-drawn a switch closes and sets the alarm off. that's why when you make your withdrawl it's best to help your-self so you can check for these little nasties. if you find them, merely insert ones underneath the pile of twenties, and then pull out the twen-ties, leaving the one-dollar bill behind to prevent the circuit from closing.

If you shoplift and see cameras, look at the brand. if it is surveillance video systems (SVS) you need not worry. these cameras look realistic to the point of pilot lights, coax, and scanning. however, they are only empty boxes.

How to make TNT

By THE SCREAMER

Probably the most important explosive compound in use today is TNT (trinitrotoluene). This and other very similar types of high explosives are all used by the military, because of their fantastic power- about 2.25 millions pounds per square inch, and their great stability. TNT also has the great advantage of being able to be melted at 82 degrees F., so that it can be poured into shells, mortars, or any other projectiles. Military TNT comes in containers which resemble dry cell batteries, and are usually ignited by an electrical charge, coupled with an electrical blasting cap, although there are other methods.

Preparation of TNT

1. Take two beakers. In the first prepare a solution of 76 percent sulfuric acid, 23 percent nitric acid and 1 percent water. In the other beaker, prepare another solution of 57 percent nitric acid and 43 percent sulfuric acid (percentages are on a weight ratio rather than volume).
2. Ten grams of the first solutions are poured into an empty beaker and placed in an ice bath.
3. Add ten grams of toluene, and stir for several minutes.
4. Remove this beaker from the ice bath and gently heat until it reaches 50 degrees C. The solution is stirred constantly while being heated.

5. Fifty additional grams of the acid, from the first beaker, are added and the temperature is held for the next ten minutes, and an oily liquid will begin to form on the top of the acid.
6. After 10 or 12 minutes, the acid solution is returned to the ice bath, and cooled to 45 degrees C. when reaching this temperature, the oily liquid will sink and collect at the bottom of the beaker. At this point, the remaining acid solution should be drawn off, by using a syringe.
7. Fifty more grams of the first acid solution are added to the oily liquid while the temperature is SLOWLY being raised to 83 degrees C. After this temperature is reached, it is maintained for a full half hour.
8. At the end of this period, the solution is allowed to cool to 60 degrees C>, and is held at this temperature for another full half hour. After this, the acid is again drawn off, leaving once more only the oily liquid at the bottom.
9. Thirty grams of sulfuric acid are added, while the oily liquid is gently heated to 80 degrees C. All temperature increases must be accomplished slowly and gently.
10. Once the desired temperature is reached, 30 grams of the second acid solution are added, and the temperature is raised from 80 degrees C> to 104 degrees C., and is held for three hours.
11. After this three hour period, the mixture is lowered to 100 degrees C. and held there for a half hour.
12. After this half hour, the oil is removed from the acid and washed with boiling water.
13. After the washing with boiling water, while being stirred constantly, the TNT will begin to solidify.
14. When the solidification has started, cold water is added to the beaker, so that the TNT will form into pellets. Once this is done, you have a good quality TNT. NOTE: the temperatures used in the preparation of TNT are EXACT, and must be used as such.

DO NOT estimate or use approximations. Buy a good centigrade thermometer. The author takes NO RESPONSIBILITY for any damage to persons or property for this formula. It is supplied for STUDY PURPOSES ONLY.

SOFT DRINK CAN BOMB AN ARTICLE FROM THE BOOK:

THE POOR MAN'S JAMES BOND BY KURT SAXON

This is an anti-personnel bomb meant for milling crowds. the bottom of a soft drink can is half cut out and bent back. a giant firecracker or other explosive is put in and surrounded with nuts and bolts or rocks. the fuse is then armed with a chemical delay in a plastic drinking straw.

```

! !
! !
! ! <-CHEMICAL INGITER
----
! !1! !
! ===== !
!* ! ! " !
! ! ! !
! ! ! ! <- BIG FIRECRACKER
! ! !% !
! ===== !
! ! !
! # !
! --- !
! ! ! <- NUTS & BOLTS
! / !
! ! !
-----

```

After first making sure there are no children nearby, the acid or glycerine is put into the straw and the can is set down by a tree or wall where it will not be knocked over. the delay should give you three to five minutes. it will then have a shattering effect on passersby.

It is hardly likely that anyone would pick up and drink from someone else's soft drink can. but if such a crude person should try to drink from your bomb he would break a nasty habit fast!

## El Pirata's Guild On How To Make A Chemical Fire Bottle

Written for: Toxic Oyster Guild 05/12/85

### Materials Required:

=====

Sulphuric Acid (Battery Acid)	Gasoline
Potassium Chlorate (Drug Store)	Sugar
Glass bottle w/stopper (roughly 1 quart size)	Small bottle or jar w/lid
Rag or absorbent paper(newspaper,towels, etc.)	
String or rubber bands	

### Procedure:

=====

1) Sulphuric Acid Must be Concentrated. If battery acid or other dilute acid is used, concentrate it by boiling until dense white fumes are given off. Container used should be of enamelware or oven glass.

CAUTION: Sulphuric acid will burn skin and destroy clothing. If any is spilled, wash it away with a large quantity of water. Fumes are also dangerous and should not be inhaled.

2) Remove the acid from heat and allow to cool to room temperature.

3) Pour gasoline into the large (1 quart) bottle until it is approximately 2/3 full.

4) Add concentrated sulphuric acid to gasoline slowly until the bottle is filled to within 1' to 2' from top. Place the stopper on the bottle.

5) Wash the outside of the bottle thoroughly with clear water.

CAUTION: If this is not done, the fire bottle may be dangerous to handle during use.

6) Wrap a clean cloth or several sheets of absorbent paper around the outside of the bottle. Tie with string or fasten with rubber bands.

7) Dissolve 1/2 cup (100 gm) of potassium chlorate and 1/2 cup (100 gm) of sugar in one cup (250 cc) of boiling water.

8) Allow the solution to cool, pour into the small bottle and cap tightly. The cooled solution should be approx. 2/3 crystals and 1/3 liquid. If there is more liquid than this, pour off excess before using.

CAUTION: Store this bottle separately from the other bottle.

How To Use:

- 1) Shake the small bottle to mix contents and pour onto the cloth or paper around the large bottle. Bottle can be used wet or after solution has dried. However, when dry, the sugar - Potassium chlorate mixture is very sensitive to spark or flame and should be handled accordingly.
- 2) Throw or launch the bottle. When the bottle breaks against a hard surface (target) the fuel will ignite.

Conclusion:

=====

This weapon proves to be very useful in torching Assholes and/or their possessions. Use your imagination.

El Pirata (c) 1985 TOG ENTERPRISES

Pyro Book ][ by Capt Hack and Grey Wolf

TIME DELAYED CHEMICAL FUSE

- 1) Put 1 teaspoon full of of potassium permanganate in a tin can.
- 2) add glycerine
- 3) wait 3-4 min.
- 4) get the hell out.. the stuff will smoke, then burst into flame..

\*\* potasium permanganate stains like iodine but worse [it's purple]  
\*\* the reaction will spatter a bit ->it can be messy...  
\*\* it doesn't matter if the amounts are uneven [ie. 1 part to 3 parts]

## THERMITE

This stuff can burn \*anything\*. [except Tungsten].. It's great for burning open a fortress fone [a pay phone, for those who do not know]

Here is the step-by-step on how to make it.

1) First you need rust. The best way to make alot of it is....

a) get an electric train transformer and attach a common nail to the PLUS (+) end of the transformer. take a glass jar and fill it with water, then put salt [table salt is fine] into the water. put the other wire into the water with the nail [leave the transformer out, of course]. Turn on the transformer and let the contraption run overnight. seperate out all the red shit [that's the rust] with a filter or a spoon. let the stuff dry [like on a paper towel] that's it! you have rust!

2) Get some aluminum filings from the hardware store [or shave your own from a bar with less that 94% pure aluminum, called duralumin]

3) Now, just mix:

8 grams rust / 3 grams aluminum filings

4) That's Thermite!! Now, to ignite it...

5) You now need some Magnesium ribbon. To get it, you can:

a) steal it from the chemistry lab at school  
b) buy it at the hardware store or from a chemical supply house.

6) Alright, shove the Magesium ribbon into the Thermite at a fuse.

7) Then light it with a blowtorch. [It won't get hot enough to ignite the Thermite, though]

8) last step: get the hell back. [it can vaporize CARBON STEEL!]

## EXPLOSIVES AND INCENDIARIES by THE RESEARCHER

INTRODUCTION: The trouble with text books on chemistry and explosives is the attitude with which they are written. They don't say, "Now I know you would like to blow holy hell out of something just for the fun of it so here is how to whip up something in your kitchen to do it". They tell you how Dupont does it or how the anchient Chinese did it but not how you can do it with the resourses and materials available to you.

Even army manuals on field expedient explosives are almost useless because they are just outlines written with the understanding that an instructor is going to fill in the blanks. It is a fun game to search out the materials that can be put together to make something go "boom". You can find what you need in grocery stores, hardware stores, and farm supplies. An interesting point to remember is that it is much easier to make a big e explosion than a small one. It is very difficult for a home experimenter to make a firecracker, but a bomb capable of blowing the walls out of a building is easy.

The king of explosives for the do-it-yourselfer is black powder. It is easy to make and when properly confined is capable of devastating power.

It is cheap and works well. Some drug stores sell sulfur under the name Flowers of Sulfur. If you use Nitrate of Soda, it will be in the form of prills (little round beads). Bake it in an oven at 250 degrees for 10-15 minutes to drive out the moisture.

Then dump a cup or two into a blender and switch it on. It will do a beautiful job of reducing it to powder. Buy a bag of charcoal briquettes at a grocery store. Put a few briquettes in a rag and pound with hammer. Dump the result into the blender, grind, then strain through a tea strainer.

Mix by volume: 6 parts potassium or Sodium Nitrate, 2 parts powdered charcoal, 1 part sulfur. This mixture will burn if ignited and will explode if ignited while tightly confined. It can be greatly improved, however, by processing it as follows:

Moisten with water until it will stick together when pinched between thumb and finger. Press it into a disposable aluminum pie pan. Bake in a preheated oven at 250 degrees for about 30 minutes--get it totally dry. Grind into as fine a powder as possible. A mortar and pestle is best.

If you use a blender at this point, there is a danger of explosion. It is not very sensitive to friction or impact, but is very sensitive to sparks. If you followed these directions, you should have a fine slate-grey powder.

When baking black powder, remember to preheat the oven. Place your pie pan approximately in the center of the oven. Do not set it on the bottom of the oven.

These warnings are to prevent hot spots that could ignite the powder causing a fire or explosion. Something went wrong once when my father-in-law was doing this and it blew the door right off the oven. His training in military demolitions included field expedient explosives. The point is that things can go wrong even when you know what you are doing. Protect yourself at all times. Use common sense. Wear safety glasses; don't stand in front of oven, etc.

#### HOW TO MAKE BLACKMATCH FUSE:

Take a flat piece of plastic or metal (brass or aluminum are easy to work with and won't rust). Drill a 1/16th inch hole through it. This is your die for sizing the fuse. You can make fuses as big as you want, but this is the right size for the pipe bomb I will be getting to later.

To about 1/2 cup of black powder add water to make a thin paste. Add 1/2 teaspoon of corn starch. Cut some one foot lengths of cotton thread. Use cotton, not silk or thread made from synthetic fibers. Put these together until you have a thickness that fills the hole in the die but can be drawn through very easily.

Tie your bundle of threads together at one end. Separate the threads and hold the bundle over the black powder mixture. Lower the threads with a circular motion so they start curling onto the mixture. Press them under with the back of a teaspoon and continue lowering them so they coil into the paste. Take the end you are holding and thread it through the die. Pull it through smoothly in one long motion.

To dry your fuse, lay it on a piece of aluminum foil and bake it in your 250 degree oven or tie it to a grill in the oven and let it hang down. The fuse must be baked to make it stiff enough for the uses it will be put to later. Air drying will not do the job. If you used Sodium Nitrate, it will not even dry completely at room temperatures.

Cut the dry fuse with sissors into 2 inch lengths and store in an air tight container. Handle this fuse carefully to avoid breaking it. You can also use a firecracker fuse if you have any available. The fuses can usually be pulled out without breaking. To give yourself some running time, you will be extending these fuses (blackmatch or firecracker fuse) with sulfured wick.

#### HOW TO MAKE SULFURED WICK

Use heavy cotton string about 1/8th inch in diameter. You can find some at a garden supply for tieing up your tomatoes. Be sure it's cotton. You can test it by lighting one end. It sould continue to burn after the match is removed and when blown out will have a smoldering coal on the end. Put some sulfur in a small container like a small pie pan and melt it in the oven at 250 degrees.

It will melt into a transparent yellow liquid. If it starts turning brown, it is too hot. Coil about a one foot length of string into it. The melted sulfur will soak in quickly. When saturated, pull it out and tie it up to cool and harden.

It can be cut to desired lengths with sissors. 2 inches is about right. These wicks will burn slowly with a blue flame and do not blow out easily in a moderate wind. They will not burn through a hole in a metal pipe, but are great for extending your other fuse. They will not throw off sparks. Blackmatch generates sparks which can ignite it along its length causing unpredictable burning times.

Now you have the basic ingredients to shake the earth like thunder. In the next installment or two, I will tell you how to put it all together to do just that. You will find that you have baked a very deadly pie. I have twice been accused of setting off dynamite in the woods. The explosive power of your little grey powder may exceed your expectations, so choose your testing ground with care.

#### HOW TO MAKE A PIPE BOMB

Buy a section of metal water pipe 1/2 by 6 inches long, threaded on both ends. Buy two metal caps to fit. These are standard items in hardware stores. Drill a 1/16th hole in the center of the pipe. This is easy with a good drill bit.

Hanson is a good brand to use. Screw a metal cap tightly on one end. Fill the pipe to within 1/2 inch of the top with black powder. Do not pack the powder. Don't even tap the bottom of the pipe to make it settle. You want the powder loose. For maximum explosive effect, you need dry, fine powder sitting loose in a very rigid container.

Wipe off any powder that has gotten onto the top or threads of the pipe. Gently screw on the second cap. Hand tighten only. Place a small piece of tape over the hole and go to your test site. Remove the tape and insert a two inch piece of black match fuse or a firecracker fuse into the hole. Place the bomb behind a large rock or tree.

Using thread or string, lightly tie a 2 inch piece of sulfured wick to the end of the fuse. Avoid letting the wick touch any objects. This might cause it to go out. Light the wick and head for cover in a direction that keeps the rock or tree between you and the bomb at all times. Get behind cover at least 50 yards away. You may not expect such a large explosion from such a small object.

Be extra cautious until you have done this a time or two and it gets real what you are dealing with. The pipe will be blown to pieces which will fly through the air like bullets. An accident could seriously wound or kill you. This is not a big firecracker. It is more like a hand grenade. The size of the bomb can be increased by using a larger pipe and caps.

To make a big noise without blowing up your pipe, cap one end only. Drill a 1/16 hole at the top of the threads at the capped end. Put in about 3 to 4 rounded teaspoonsful of powder. Pack about 2 inches of wadding on top of the powder. Toilet paper or kleenex is good for this. Pack it tight. Open up a safety pin and stick it into the hole. Work it around to loosen up the powder so a fuse can be inserted. When this goes off, the recoil will be tremendous. You will lose your pipe unless you brace it securely against something.

The pipe can be reloaded and used again. A fun trick is to mount the pipe pointing upward. Drop a tin can over the open end and light the fuse. The can will be blown high into the air. Campbell's soup cans are great for this.

#### HOW TO MAKE ROCKET FUEL

This is easy to make and fun to play with. Mix equal parts by volume Potassium or So dium Nitrate and granulated sugar. Pour a big spoonful of this into a pile. Stick a piece of blackmatch fuse into it; light; and step back. This is also a very hot incendiary. A little imagination will suggest a lot of experiments for this.

#### ANOTHER ROCKET FUEL

Mix equal parts by volume of zinc dust and sulfur. Watch out if you experiment with this. It goes off in a sudden flash. It is not a powerful explosive, but is violent stuff even when not confined because of its fast burning rate.

--- As I continue from this point some of the ingredients are going to be harder to get without going through a chemical supply. I try to avoid this. I happen to know that B. Prieser Scientific (local to my area) has been instructed by the police to send them the names of anyone buying chemicals in certain combinations. For example, if a person were to buy Sulfuric acid, Nitric acid and Toluene (the makings for TNT) in one order the police would be notified. I will do the best I can to tell you how to make the things you need from commonly available materials, but I don't want to leave out something really good because you might have to scrounge for an ingredient. I am guessing you would prefer it that way.

#### HOW TO MAKE AN EXPLOSIVE FROM COMMON MATCHES

The word "safety" in safety matches is misleading. The chemical on the heads of safety matches is a powerful explosive. It is similar to black powder but has a lower ignition temperature (more sensative to heat) and unlike black powder is easily detonated by impact.

This feature moves it up into the high explosives class. To test this, lay a paper safety match on a hard flat surface and hit the head sharply with a hammer. What do you know! It goes bang! To collect a quantity of this explosive, it is best to use wooden safety matches. Buy several cartons. They're cheap. Note that these should be safety matches, not the strike anywhere kind.

Pinch the head near the bottom with a pair of wire cutters to break it up; then use the edges of the cutters to scrape off the loose material. It gets easy with practice. You can do this while watching TV and collect enough for a bomb without dying of boredom.

Once you have a good batch of it, you can load it into a pipe instead of black powder. Be careful not to get any in the threads, and wipe off any that gets on the end of the pipe. Never try to use this stuff for rocket fuel. A science teacher was killed that way.

Just for fun while I'm on the subject of matches, did you know that you can strike a safety match on a window pane? Hold a paper match between your thumb and first finger. With your second finger, press the head firmly against a large window. Very quickly, rub the match down the pane about 2 feet while maintaining the pressure. The friction will generate enough heat to light the match.

Another fun trick is the match rocket. Tightly wrap the top half of a paper match with foil. Set it in the top of a pop bottle at a 45 degree angle. Hold a lighted match under the head until it ignites. If you got it right, the match will zip up and hit the ceiling.

I just remembered the match guns I used to make when I was a kid. These are made from a bicycle spoke. At one end of the spoke is a piece that screws off. Take it off and screw it on backwards. You now have a piece of stiff wire with a small hollow tube on one end. Pack the material from a couple of wooden safety matches into the tube. Force the stem of a match into the hole. It should fit very tightly. Hold a lighted match under the tube until it gets hot enough to ignite the powder. It goes off with a bang.

--- For later projects, like a chemical time delay fuse, you will need some concentrated sulfuric acid. So, I better tell you how to make it.

## HOW TO MAKE CONCENTRATED SULFURIC ACID FROM BATTERY ACID

Go to an auto supply store and ask for "a small battery acid". This should only cost a few dollars (about 4 dollars). What you will get is about a gallon of dilute sulfuric acid. Put a pint of this into a heat resistant glass container. The glass pitchers used for making coffee are perfect.

Do not use a metal container. Use an extension cord to set up a hotplate out doors. Boil the acid until white fumes appear. As soon as you see the white fumes, turn off the hot plate and let the acid cool. Pour the now concentrated acid into a glass container. The container must have a glass stopper or plastic cap -- no metal. It must be air tight. Otherwise, the acid will quickly absorb moisture from the air and become diluted. Want to know how to make a time bomb that doesn't tick and has no wires or batteries? Hold on to your acid and follow me into the next installment.

## HOW TO MAKE A CHEMICAL TIME DELAY FUSE:

To get an understanding of how this is going to work, mix up equal parts by volume Potassium chlorate and granulated sugar. Pour a spoonful of the mixture in a small pile and make a depression in the top with the end of a spoon. Using a medicine dropper, place one drop of concentrated sulfuric acid in the depression and step back.

It will snap and crackle a few times and then burst into vigorous flames. To make the fuse, cut about 2 inches off a plastic drinking straw. Tamp a small piece of cotton in one end. On top of this put about an inch of the chlorate/sugar mixture.

Now lightly tamp in about a quarter inch of either glass wool or asbestos fibers. Secure this with the open end up and drop in 3 or 4 drops of sulfuric acid. After a few minutes the acid will soak through the fibers and ignite the mixture.

The time delay can be controlled by the amount of fiber used and by varying how tightly it is packed. Don't use cotton for this. The acid will react with cotton and become weakened in the process. By punching a hole in the side of the straw, a piece of blackmatch or other fuse can be inserted and used to set off the device of your choice.

Potassium chlorate was very popular with the radical underground. It can be used to make a wide variety of explosives and incendiaries, some of them extremely dangerous to handle. The radicals lost several people that way. But, don't worry. I am not going to try to protect you from yourself. I have decided to tell all. I will have more to say about Potassium chlorate, but for now, let's look at a couple of interesting electric fuses.

### HOW TO MAKE AN ELECTRIC FUSE

Take a flashlight bulb and place its glass tip down on a file. Grind it down on the file until there is a hole in the end. Solder one wire to the case of the bulb and another to the center conductor at the end. Fill the bulb with black powder or powdered match head. One or two flashlight batteries will heat the filament in the bulb causing the powder to ignite.

### ANOTHER ELECTRIC FUSE

Take a medium grade of steel wool and pull a strand out of it. Attach it to the ends of two pieces of copper wire by wrapping it around a few turns and then pinch on a small piece of solder to bind the strand to the wire. You want about 1/2 inch of steel strand between the wires. Number 18 or 20 is a good size wire to use.

Cut a 1/2 by 1 inch piece of cardboard of the type used in match covers. Place a small pile of powdered match head in the center and press it flat. Place the wires so the steel strand is on top of and in contact with the powder. Sprinkle on more powder to cover the strand.

The strand should be surrounded with powder and not touching anything else except the wires at its ends. Place a piece of blackmatch in contact with the powder. Now put a piece of masking tape on top of the lot, and fold it under on the two ends. Press it down so it sticks all around the powder.

The wires are sticking out on one side and the blackmatch on the other. A single flashlight battery will set this off.

### ELECTRIC FUSE # 3

An excellent electric fuse can be bought ready made at hobby and toy stores. They are sold for setting off model rockets.

### MORE SPONTANIOUS COMBUSTION

Some of the ingredients for these can only be had from a chemical supply so they are not my favorites. Look for powdered aluminum at a good painting supply.

#### METHOD # 1

Scatter out a few crystals of chromic anhydride. Drop on a little ethyl alcohol. It will burst into flame immediately.

#### METHOD # 2

Mix by weight, four parts ammonium chloride, one part ammonium nitrate, four parts powdered zinc. Pour out a small pile of this and make a depression on top. Put one or two drops of water in the depression. Stay well back from this.

#### METHOD # 3

Put one gram of powdered potassium permanganate into a paper cup. Drop two drops of glycerine onto it. After a few seconds it will burst into flames.

METHOD # 4

Spoon out a small pile of powdered aluminum. Place a small amount of sodium peroxide on top of this. A volume the size of a small pea is about right. One drop of water will cause this to ignite in a blinding flare.

METHOD # 5

Mix by volume 3 parts concentrated sulfuric acid with 2 parts concentrated nitric acid. Hold a dropper of turpentine about 2 feet above the mixture. When drops strike the acid they will burst into flame.

HOW TO MAKE NITROGEN TRIIODIDE

Here are some notes I took four years ago on how to make this wild explosive that can be detonated by a fly walking on it.

Five grams iodine, three grams potassium iodide, 20 ml. concentrated ammonium hydroxide, filter paper, funnel.

Stir the potassium iodide and iodine together in a beaker with 50 ml. of water. Add the ammonium hydroxide with stirring until no more precipitate forms.

Filter and spread a thin layer of the wet solid on several filter papers. Break the filter papers into many small pieces and allow to dry for several hours. On drying, the paper is extremely sensitive to touch and will explode violently with the slightest disturbance. Can be handled safely when wet. Do not let any sizeable quantity of the dry material accumulate.

--- I was able to buy concentrated ammonium hydroxide from a photographic supply.

I. COMMON "WEAK" EXPLOSIVES.

A. GUNPOWDER:

75% POTASSIUM NITRATE  
15% CHARCOAL  
10% SULFUR

The chemicals should be ground into a fine powder (seperately!) with a mortar & pestle. If gunpowder is ignited in the open, it burns fiercely, but if in a closed space it builds up pressure from the released gases and can explode the container. Gunpowder works like this: the potassium nitrate oxidizes the charcoal and sulfur, which then burn fiercely. carbon dioxide and sulfur dioxide are the gases released.

B. AMMONAL:

Ammonal is a mixture of ammonium nitrate (a strong oxidizer) with aluminum powder (the 'fuel' in this case). I am not sure of the % composition for ammonal, so you may want to experiment a little using small amounts.

C. CHEMICALLY IGNITED EXPLOSIVES:

1. using various chemicals, I have developed a mixture that works very well for imitating volcanic eruptions. i have given it the name 'mpg volcanite'

Here it is: potassium chlorate + potassium perchlorate + ammonium nitrate + ammonium dichromate + potassium nitrate + sugar + sulfur + iron filings + charcoal + zinc dust + some coloring agent.

(scarlet= strontium nitrate, purple= iodine crystals, yellow= sodium chloride, crimson= calcium chloride, etc...).

PEROXYACETONE

PEROXYACETONE IS EXTREMELY FLAMMABLE AND HAS BEEN REPORTED TO BE SHOCK SENSITIVE.

MATERIALS-

4ML ACETONE

4ML 30% HYDROGEN PEROXIDE

4 DROPS CONC. HYDROCHLORIC ACID

150MM TEST TUBE

Add 4ml acetone and 4ml hydrogen peroxide to the test tube. then add 4 drops concentrated hydrochloric acid. In 10-20 minutes a white solid should begin to appear. if no change is observed, warm the test tube in a water bath at 40 celsius. Allow the reaction to continue for two hours. Swirl the slurry and filter it. Leave out on filter paper to dry for at least two hours. To ignite, light a candle tied to a meter stick and light it (while staying at least a meter away) .

B. SMOKE SMOKE SMOKE...

The following reaction should produce a fair amount of smoke. Since this reaction is not all that dangerous you can use larger amounts if necessary

6 pt. ZINC POWDER

1 pt. SULFUR POWDER

Insert a red hot wire into the pile, step back.

There are many other experiments I could have included, but i will save them for the next chemist's corner article. upcoming articles will include glow-in-the-dark reactions, 'party' reactions, things you can do with household chemicals , etc...

I would like to give credit to a book by shakashari entitled "Chemical demonstrations" for a few of the precise amounts of chemicals in some experiments.

...ZAPHOD BEEBLEBROX/MPG!

THE CHEMIST'S CORNER #2: HOUSEHOLD CHEMICALS, BY ZAPHOD BEEBLEBROX/MPG

This article deals with instructions on how to do some interesting experiments with common household chemicals. Some may or may not work depending on the concentration of certain chemicals in different areas and brands. I would suggest that the person doing these experiments have some knowledge of chemistry, especially for the more dangerous experiments.

I am not responsible for any injury or damage caused by people using this information. It is provided for use by people knowledgeable in chemistry who are interested in such experiments and can safely handle such experiments.

#### I. A LIST OF HOUSEHOLD CHEMICALS AND THEIR COMPOSITION

VINEGAR: 3-5% ACETIC ACID	BAKING SODA: SODIUM BICARBONATE
DRAIN CLEANERS: SODIUM HYDROXIDE	SANI-FLUSH: 75% SODIUM BISULFATE
AMMONIA WATER: AMMONIUM HYDROXIDE	CITRUS FRUIT: CITRIC ACID
TABLE SALT: SODIUM CHLORIDE	SUGAR: SUCROSE
MILK OF MAGNESIA-MAGNESIUM HYDROXIDE	TINCTURE OF IODINE- 4% IODINE
RUBBING ALCOHOL- 70 OR 99% (DEPENDS ON BRAND)	ISOPROPYL ALCOHOL (DO NOT DRINK!)

#### GENERATING CHLORINE GAS

This is slightly more dangerous than the other two experiments, so you should know what you're doing before you try this...

Ever wonder why ammonia bottles always say 'do not mix with chlorine bleach', and visa-versa? That's because if you mix ammonia water with ajax or something like it, it will give off chlorine gas. To capture it, get a large bottle and put ajax in the bottom. then pour some ammonia down into the bottle. since the chlorine is heavier than air, it will stay down in there unless you use large amounts of either ajax or ammonia (don't!). for something fun to do with chlorine STAY TUNED....

#### CHLORINE + TURPENTINE

Take a small cloth or rag and soak it in turpentine. Quickly drop it into the bottle of chlorine. It should give off a lot of black smoke and probably start burning...

#### GENERATING HYDROGEN GAS

To generate hydrogen, all you need is an acid and a metal that will react with that acid. Try vinegar (acetic acid) with zinc, aluminum, magnesium, etc. You can collect hydrogen in something if you note that it is lighter than air.... light a small amount and it burns with a small \*pop\*.

Another way of creating hydrogen is by the electrolysis of water. this involve sseperating water (H<sub>2</sub>O) into hydrogen and oxygen by an electric current. To do this, you need a 6-12 volt battery (or a DC transformer), two test tubes, a large bowl, two carbon electrodes (take them out of an unworking 6-12 volt battery), and table salt. Dissolve the salt in a large bowl full of water. Submerge the two test tubes in the water and put the electrodes inside them, with the mouth of the tube aiming down. Connect the battery to some wire going down to the electrodes.

This will work for a while, but chlorine will be generated along with the oxygen which will corrode your copper wires leading to the carbon electrodes... (the table salt is broken up into chlorine and sodium ions, the chlorine comes off as a gas with oxygen while sodium reacts with the water to form sodium hydroxide....). therefore, if you can get your hands on some sulfuric acid, use it instead. it will not affect the reaction other than making the water conduct electricity.

Addendum 4/12/91: DO NOT use a transformer that outputs AC current!

Not only is AC inherently more dangerous than DC, it also produces equal amount of Hydrogen and Oxygen at each electrode.

#### HYRDOGEN + CHLORINE

Take the test tube of hydrogen and cover the mouth with your thumb. Keep it inverted, and bring it near the bottle of chlorine (not one that has reacted with turpentine). Say "goodbye test tube", and drop it into the bottle. The hydrogen and chlorine should react and possibly explode (depending on purity and amount of each gas). An interesting thing about this is they will not react if it is dark and no heat or other energy is around. When a light is turned on, enough energy is present to cause them to react...

#### PREPARATION OF OXYGEN

Get some hydrogen peroxide (from a drug store) and manganese dioxide (from a battery- it's a black powder). Mix the two in a bottle, and they give off oxygen. If the bottle is stoppered, pressure will build up and shoot it off.

Try lighting a wood splint and sticking it (when only glowing) into the bottle. The oxygen will make it burst into flame. The oxygen will allow things to burn better...

#### IODINE

Tincture of iodine contains mainly alcohol and a little iodine. To seperate them, put the tincture of iodine in a metal lid to a bottle and heat it over a candle. Have a stand holding another metal lid directly over the tincture (about 4-6 inches above it) with ice on top of it. The alcohol should evaporate, and the iodine should sublime, but should reform iodine crystals on the cold metal lid directly above. If this works (I haven't tried), you can use the iodine along with household ammonia to form nitrogen triiodide.

...ZAPHOD BEEBLEBROX/MPG!

CHLOROX-DRAINNO By The Mortician Sysop of: The Morgue (201)376-4462

I am not too sure on how this works but I am pretty sure that you can make a really powerful bomb by taking a can of draino and mixing it with Chlorox. I think that these two compounds will spontaneously explode so don't just pour them together.

I think what you do is get the draino in a cardboard can and then put it in a bucket of chlorox and what will happen is either the draino or chlorox will eat through the cardboard and they will meet and explode.

You might want to experiment with this by rigging it up so you can cause the two to combine while you stand a distance a way. I reccomend extreme caution with this and wear goggles....

Just like pour some chlorox into a pan and then have a can of draino with a string tied to it so you can make it spill into the chlorox... Be Careful. I don't need a law suit... If you find anything out call The Morgue and leave me feedback and/or get me in chat and I will update this file with credit to you....

Addendum 4/12/91: All this reaction does is produce heat and gas.

I have found that Pool Chlorine tablets with strong household ammonia react to produce LOTS of chlorine gas and heat... also mixing the tablets with rubbing alcohol produces heat, a different (and highly flammable) gas, and possibly some sort of acid (it eats away at just about anything it touches)

If you have any more info, send me mail: KADOKEV@IITVAX (Bitnet)  
kadokev@iitvax.iit.edu

I'd especially appreciate chemical formulas, or other interesting combinations (also a source for the pure chemicals in the tablets and in household ammonia)

\*End Addendum

## HOW TO MAKE DRUGS !

IN NO WAY AM I RESPONSIBLE FOR FOR ANY INJURIES CAUSED BY THE USE/MISUSE OF THESE DRUGS. YOU SHOULD TREAT THESE DRUGS LIKE ALCOHOL. USE THEM ONLY AS AN ADDED EXPERIENCE IN LIFE, RATHER THAN AN ESCAPE.

THESE RECIPES ARE ALL FOUND IN A BOOK WHICH HAS RELIABLE SOURCES. ALL SHOULD WORK IF MADE PROPERLY.

### BANANDINE (MADE FROM BANANA!)

BANANAS DO CONTAIN A SMALL QUANTITY OF A MILD SHORT LASTING PSYCHODELIC DRUG. THERE ARE BETTER WAYS OF GETTING HIGH BUT THE GREAT ADVANTAGE OF THIS IS THAT BANANAS ARE LEGAL (FOR NOW)

- 1] OBTAIN 15 LBS OF RIPE YELLOW BANANAS
- 2] PEEL THEM ALL, EAT THE CHOW, KEEP THE PEELS.
- 3] WITH A SHARP KNIFE, SCRAPE OFF THE INSIDES OF THE PEELINGS, AND SAVE THE SCRAPED MATERIAL.
- 4] PUT ALL SCRAPED MATERIAL IN A LARGE POT AND ADD WATER. BOIL FOR THREE TO FOUR HOURS UNTIL IT HAS ATTAINED A SOLID PASTE.
- 5] SPREAD THIS PASTE ON COOKIE SHEETS AND DRY IN OVEN FOR ABOUT 20 MIN. TO A HALF AN HOUR. THIS WILL RESULT IN A FINE BLACK POWDER ROLL IT UP AND SMOKE ABOUT 3-4 OF THOSE DUDES

### PEANUTS!

- 1] OBTAIN A POUND OF PEANUTS.
- 2] SHELL THEM, SAVING THE SKINS AND DISCARDING THE SHELLS.
- 3] PORK OUT ON THE NUTS WHILE WATCHING David Letterman ONE NIGHT.
- 4] GRIND UP THE SKINS, ROLL THEM, SMOKE THEM.

Any fool can grow their own marijuana.... just plant the seeds in a warm, sunny and not too public place, water and fertilize as you would any other plant, and in a short while you'll have your own homegrown weed. I've heard that you can kill mites by soaking some tobacco (buy a pack of plain pipe tobacco) in water, and spraying it on the leaves (you don't want to use toxic chemicals on something you're going to smoke later)

If you're not used to the stuff, cut it with 50% tobacco, and smoke it in a filtered pipe or use the mixture to refill a cigarette- the tar content is MUCH higher than that of a regular cigarette.

Remember, cultivation is a FEDERAL crime, so if you can do it at home, just pick a room with no windows, and put in some grow lights (sodium vapor lamps are reputed to be the best- steal a couple streetlights) and a water spigot.

## TRIPWIRES

by The Mortician

Well first of all I reccommend that you read the file on my board about landmines... If you can't then here is the concept.

You can use an m-80,h-100, blockbuster or any other type of explosive that will light with a fuse. Now the way this works is if you have a 9 volt battery, get either a solar igniter (preferably) or some steel wool you can create a remote ignition system. What you do it set up a schematic like this.

```

----->+ batery
steel ||          ->- batery
wool  ||          /
:==:--- <--fuse  \
  ||              /
---- spst switch--\

```

So when the switch is on the currnet will flow through the steel wool or igniter and heat up causing the fuse to light.

Note: For use with steel wool try it first and get a really thin piece of wire and pump the current through it to make sure it will heat up to light the explosive.

Now the thing to do is plant your explosive wherever you want it to be,bury it and cover the wires. Now take a fishing line (about 20 lb. test) and tie one end to a secure object. Have your switch secured to something and make a loop on the other end on the line. Put the loop around the switch such that when pulled it will pull the switch and set off the explosive.

To ignite the explosive... The thing to do is to experiment with this and find your best method... Let me know on any good kills, or new techniques... On my board... (201)376-4462

Addendum 4/12/91:

I would suggest you try the clothespin trick, it works much better.

BOOBY TRAP TRIP WIRES..... BY Vlad Tepes (of Chgo C64 fame)

Here is a method for constructing boobytraps which I personally invented, and which I have found to work better than any other type of release booby trap.

There are many possible variations on this design, but the basic premise remains the same. What you'll need is 3-4 nails each 2 inches long and soft enough to bend easily (galvanized iron works well), some wire or fishing line, some string or rope, and a really sick mind.

Hammer two of the nails into the trunk of a tree (about one inch apart) so they form a horizontal line. They should be angled slightly upward, about 30 degrees.

Bend each nail Downward about one inch out from the trunk. Take your nefarious device (say a small rock suspended in a tree) and rig a rope or string so it comes DOWN towards the two nails. Tie a loop in the string so the loop \*just\* reaches between the two nails, and pass a third nail between the two nails with the loop around this nail between the two others (see diagrams)

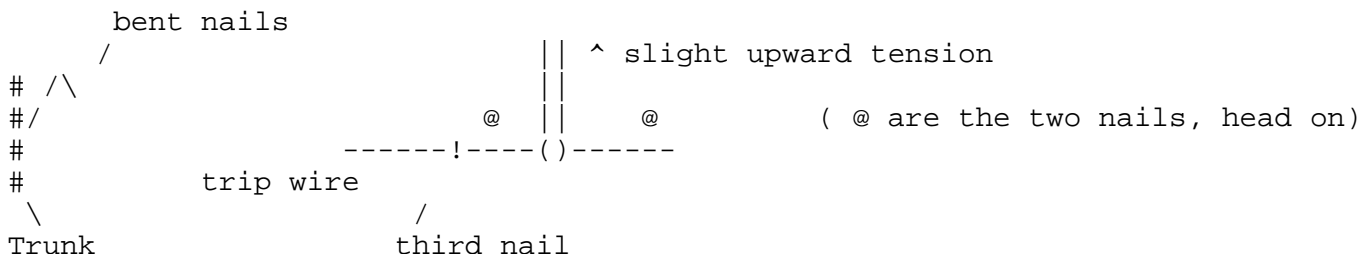

Now tie one end of the fishing line to the head of the third nail, and the other end around another tree or to a nail (in another tree, a root or a stump etc).

When somebody pulls on the trip wire, the nail will be pulled out and your sick creation will be released to do it's damage (try tying it to a firing pin). There are several possible variations. More than one trip wire can be attached to the same nail, or this device can be used to arm a second trip wire. Large wire staples or hook and eye loops can be used to replace the two bent nails.

A more interesting variation uses a straight piece of metal rod with a hole at each end, or with a short wire loop welded to each end. One end is attached to the tripwire, the other is attached to a spring.

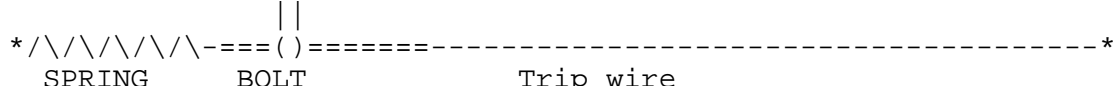

With this design the loop will be released if the tripwire is pulled or if it is broken. The spring should be under moderate tension and well oiled.

RECIPE FOR A STANDARD PLASTIC EXPLOSIVE

INGREDIENTS:

GASOLINE - 1 PART      OIL - 1 HALF PART      STYROFOAM - 1 PART

1) MELT STYROFOAM. -REMEMBER NEVER AT ANY TIME LET THE MIXTURE GET TOO HOT.

Addendum 4/12/91

Acetone will dissolve the styrofoam, and requires no heat- this is an ingredient in nail polish remover, or it is available at any good automotive supply store in the paint section.

A nice trick is to walk into a store, grab a bottle of nail polish remover (check the ingredients, it should have acetone in it) then "accidentally" pour it into a large stack of (uncoated) styrofoam coolers and wander off.

\*End Addendum

2) LET COOL TO A THICK VISCOSITY.

3) MIX 3 INGREDIENTS TOGETHER IN FOLLOWING ORDER: FIRST ADD STYROFOAM, THEN OIL, THEN GAS.

4) MIX IN A DEEP POT - KEEP MIXTURE AWAY FROM ANY TYPE OF FIRE! DO THIS STEP WITH EXTREME CAUTION.

5) LET THE MIXTURE COOL TO A LITTLE BIT WARMER THAN ROOM TEMPERATURE - AROUND 88 DEGREES FARENHEIT.

6) MOLD THE MIXTURE HOW YOU WANT. (DIFFERENT SHAPES WILL MAKE IT MORE OR LESS LETHAL).

OPTIONAL: YOU CAN ADD NUTS, BOLTS, AND SCREWS WHILE MIXING, ALONG WITH GUNPOWDER, 2 M-80'S, OR ANY OTHER TYPE OF EXPLOSIVE TO MAKE IT THE EQUIVILANT OF A MOLOTOV COCKTAIL.

NOTE: THE FRAGMENTS (NUTS, BOLT, ETC.) ARE DEADLY. THEY WILL PENETRATE A BRICK WALL WHEN THE MIXTURE IS DETONATED.

DETONATION

1) THE MIXTURE CAN BE THROWN, BUT SOMETIMES DETONATION DOES NOT OCCUR.

2) THE MIXTURE CAN BE WIRED FOR AN ELECTRIC CHARGE TO BE SENT THROUGH IT, IT WILL DETONATE WITHOUT DOUBT. A REGULAR FUSE CAN BE SENT THROUGH IT ALSO. IF THIS METHOD IS USED, SOME SORT OF TIMER IS RECOMMENDED.

Addendum 4/12/91: This just burns and smokes, WILL NEVER explode.. don't bother!

Nitroglycerin [heretofore Nitro] is a very powerful high- explosive. I am not sure who invented it but he probably didn't-- the first person to make it probably blew himself up and his friend got the info off his notes.

Well anyway, the next best thing to Nitro is TNT which is ten times harder to make but also ten times safer to make. If you can't use common sense then dont even TRY to make this stuff--a few drops can blow off your hand in the right circumstances.

To make Nitro:

Mix 100 parts fuming nitric acid (for best results it should have a specific gravity of 50 degrees Baume') with 200 parts sulphuric acid.

This is going to be HOT at first--it won't splatter if you pour the nitric INTO the sulphuric but don't try it the other way around. The acid solutions together can dissolve flesh in a matter of seconds so take the proper measures for God's sake!!!

When cool, add 38 parts glycerine as slowly as possible. Let it trickle down the sides of the container into the acids or it won't mix thourily and the reaction could go to fast--which causes enough heat to ignite the stuff.

Stir with a **\*\*GLASS\*\*** rod for 15 seconds or so then **CARFULLY** pour it into 20 times it's **\*VOLUME\*** of water. It will visibly precipitate immediatly. there will be twice as much Nitro as you used glycerin and it is easy to separate. Mix it with baking soda as soon as you have separated it-- this helps it not to go off spontainiously.

Addendum 4/12/91: Do NOT let the temperature get above 32 degrees centigrade!!!

NOTES: Parts are by weight and he Baume' scale of spicific gravity can be found in most chem. books. You can get fuming nitric and sulfuric acids wherever good chemicals or fertilizers are sold.

It is positivly **\*STUPID\*** to make more than 200 grams of Nitro at a time. When mixing the stuff wear goggles, gloves, etc. When I first made the stuff I had the honor of having it go off by itself (I added too much glycerine at a time.)

I was across the room at the time, but I felt the impact--so did the table it was on as well as the window it was next to--they were both smashed by only 25 grams in an open bowl. Oh, yes, glycerine you can get at any pharmacy and you need an adult signature for the acids. Any bump can make Nitro go off if you don't add the bicarbonate of (baking) soda--but even with that, if it gets old I wouldn't play catch with it.

Addendum 4/12/91: Freezing it will make it less sensitive to shock.

Once you have made the Nitro and saturated it with Bicarb. you can make a really powerful explosive that won't go off by itself by simply mixing it with as much cotton as you can and then saturating that with molten (but as cool as possible, of course) parifine--just enough to make it sealed and hard. Typically, use the same amounts (by weight) of each Nitro, cotton and paraffin. This, when wrapped in newspaper, was once known as "Norbin & Ohlsson's Patent Dynamite," but that was back in 1896.

## Improvised Explosives

Gelatine Explosive from Anti-Freeze

Written by: The Lich

This explosive is almost the same as the nitro-gelatin plastique explosive except that it is supple and pliable to -10 to -20 deg. C

Antifreeze is easier to obtain than glycerine and is usually cheaper. It needs to be freed of water before the manufacture and this can be done by treating it with calcium chloride until a specific gravity of 1.12 @ 0 deg. C. or 1.11 @ 20 deg. C. is obtained.

This can be done by adding calcium chloride to the antifreeze and checking with a hydrometer and continue to add calcium chloride until the proper reading is obtained. The antifreeze is then filtered to remove the calcium chloride from the liquid. This explosive is superior to nitro-gelatin in that it is easier to collidon the IMR smokeless powder into the explosive and that the 50/50 ether ethyl alcohol can be done away with. It is superior in that the formation of the collidon is done very rapidly by the nitroethelene glycol.

It's detonation properties are practically the same as the nitro-gelatine. Like the nitro-gelatine it is highly flammable and if caught on fire the chances are good that the flame will progress to detonation. In this explosive as in nitro-gelatine the addition of 1% sodium carbonate is a good idea to reduce the chance of recidual acid being present in the final explosive. The following is a slightly different formula than nitro-gelatine:

Nitro-glycol 75% Guncotton (IMR) 6% Potassium Nitrate 14% Flour 5%

In this process the 50/50 step is omitted. Mix the potassium nitrate with the nitro-glycol. Remember that this nitro-glycol is just as sensitive to shock as is nitroglycerin.

The next step is to mix in the baking flour and sodium carbonate. Mix these by kneading with gloved hands until the mixture is uniform. This kneading should be done gently and slowly. The mixture should be uniform when the IMR smokeless powder is added. Again this is kneaded to uniformity. Use this explosive as soon as possible.

If it must be stored, store in a cool, dry place (0-10 deg. C.). This explosive should detonate at 7600-7800 m/sec.. These two explosives are very powerful and should be sensitive to a #6 blasting cap or equivalent.

These explosives are dangerous and should not be made unless the manufacturer has had experience with this type compound. The foolish and ignorant may as well forget these explosives as they won't live to get to use them.

Don't get me wrong, these explosives have been manufactured for years with an amazing record of safety. Millions of tons of nitroglycerine have been made and used to manufacture dynamite and explosives of this nature with very few mis haps.

Nitroglycerin and nitroglycol will kill and their main victims are the stupid and foolhardy. Before manufacturing these explosives take a drop of nitroglycerin and soak into a small piece of filter paper and place it on an anvil.

Hit this drop with a hammer and don't put any more on the anvil. See what I mean! This explosive compound is not to be taken lightly. If there are any doubts DON'T.

Improvised Explosives Plastique Explosive from Aspirin by: The Lich

This explosive is a phenol derivative. It is toxic and explosive compounds made from picric acid are poisonous if inhaled, ingested, or handled and absorbed through the skin. The toxicity of this explosive restricts its use due to the fact that over exposure in most cases causes liver and kidney failure and sometimes death if immediate treatment is not obtained.

This explosive is a cousin to T.N.T. but is more powerful than its cousin. It is the first explosive used militarily and was adopted in 1888 as an artillery shell filler. Originally this explosive was derived from coal tar but thanks to modern chemistry you can make this explosive easily in approximately three hours from acetylsalicylic acid (aspirin purified).

This procedure involves dissolving the acetylsalicylic acid in warm sulfuric acid and adding sodium or potassium nitrate which nitrates the purified aspirin and the whole mixture drowned in water and filtered to obtain the final product. This explosive is called trinitrophenol. Care should be taken to ensure that this explosive is stored in glass containers. Picric acid will form dangerous salts when allowed to contact all metals except tin and aluminum. These salts are primary explosive and are super sensitive. They also will cause the detonation of the picric acid.

To make picric acid obtain some aspirin. The cheaper brands work best but buffered brands should be avoided. Powder these tablets to a fine consistency. To extract the acetylsalicylic acid from this powder place this powder in methyl alcohol and stir vigorously. Not all of the powder will dissolve. Filter this powder out of the alcohol. Again wash this powder that was filtered out of the alcohol with more alcohol but with a lesser amount than the first extraction. Again filter the remaining powder out of the alcohol. Combine the now clear alcohol and allow it to evaporate in a pyrex dish. When the alcohol has evaporated there will be a surprising amount of crystals in the bottom of the pyrex dish.

Take forty grams of these purified acetylsalicylic acid crystals and dissolve them in 150 ml. of sulfuric acid (98%, specific gravity 1.8) and heat to dissolve all the crystals. This heating can be done in a common electric frying pan with the thermostat set on 150 deg. F. and filled with a good cooking oil.

When all the crystals have dissolved in the sulfuric acid take the beaker, that you've done all this dissolving in (600 ml.), out of the oil bath. This next step will need to be done with a very good ventilation system (it is a good idea to do any chemistry work such as the whole procedure and any procedure on this disk with good ventilation or outside). Slowly start adding 58 g. of sodium nitrate or 77 g. of potassium nitrate to the acid mixture in the beaker very slowly in small portions with vigorous stirring. A red gas (nitrogen trioxide) will be formed and this should be avoided.

The mixture is likely to foam up and the addition should be stopped until the foaming goes down to prevent the overflow of the acid mixture in the beaker. When the sodium or potassium nitrate has been added the mixture is allowed to cool somewhat (30- 40 deg. C.). The solution should then be dumped slowly into twice it's volume of crushed ice and water. The brilliant yellow crystals will form in the water. These should be filtered out and placed in 200 ml. of boiling distilled water. This water is allowed to cool and then the crystals are then filtered out of the water. These crystals are a very, very pure trinitrophenol. These crystals are then placed in a pyrex dish and places in an oil bath and heated to 80 deg. C. and held there for 2 hours. This temperature is best maintained and checked with a thermometer.

The crystals are then powdered in small quantities to a face powder consistency. These powdered crystals are then mixed with 10% by weight wax and 5% vaseline which are heated to melting temperature and poured into the crystals. The mixing is best done by kneading together with gloved hands. This explosive should have a useful plasticity range of 0-40 deg. C.. The detonation velocity should be around 7000 m/sec.. It is toxic to handle but simply made from common ingredients and is suitable for most demolition work requiring a moderately high detonation velocity. It is very suitable for shaped charges and some steel cutting charges. It is not as good an explosive as C-4 or other R.D.X. based explosives but it is much easier to make. Again this explosive is very toxic and should be treated with great care.

AVOID HANDLING BARE-HANDED, BREATHING DUST AND FUMES, AVOID ANY CHANCE OF INGESTION. AFTER UTENSILS ARE USED FOR THE MANUFACTURE OF THIS EXPLOSIVE RETIRE THEM FROM THE KITCHEN AS THE CHANCE OF POISONING IS NOT WORTH THE RISK. THIS EXPLOSIVE, IF MANUFACTURED AS ABOVE, SHOULD BE SAFE IN STORAGE BUT WITH ANY HOMEMADE EXPLOSIVE STORAGE IS NOT RECOMMENDED AND EXPLOSIVES SHOULD BE MADE UP AS NEEDED.

Improvised Explosives Plastique Explosive from Bleach by: The Lich

This explosive is a potassium chlorate explosive. This explosive and explosives of similar composition were used in World War II as the main explosive filler in grenades, land mines, and mortar used by French, German, and other forces involved in that conflict. These explosives are relatively safe to manufacture.

One should strive to make sure these explosives are free of sulfur, sulfides, and picric acid. The presence of these compounds result in mixtures that are or can become highly sensitive and possibly decompose explosively while in storage. The manufacture of this explosive from bleach is given as just an expedient method. This method of manufacturing potassium chlorate is not economical due to the amount of energy used to boil the solution and cause the 'dissociation' reaction to take place. This procedure does work and yields a relatively pure and a sulfur/sulfide free product. These explosives are very cap sensitive and require only a #3 cap for instigating detonation.

To manufacture potassium chlorate from bleach (5.25% sodium hypochlorite solution) obtain a heat source (hot plate etc.) a battery hydrometer, a large pyrex or enameled steel container (to weigh chemicals), and some potassium chloride (sold as salt substitute). Take one gallon of bleach, place it in the container and begin heating it. While this solution heats, weigh out 63 g. potassium chloride and add this to the bleach being heated. Bring this solution to a boil and boiled until when checked by a hydrometer the reading is 1.3 (if a battery hydrometer is used it should read full charge).

When the reading is 1.3 take the solution and let it cool in the refrigerator until it's between room temperature and 0 deg. C.. Filter out the crystals that have formed and save them. Boil the solution again until it reads 1.3 on the hydrometer and again cool the solution. Filter out the crystals that have formed and save them. Boil this solution again and cool as before.

Filter and save the crystals. Take these crystals that have been saved and mix them with distilled water in the following proportions: 56 g. per 100 ml. distilled water. Heat this solution until it boils and allow it to cool. Filter the solution and save the crystals that form upon cooling. The process of purification is called fractional crystallization. These crystals should be relatively pure potassium chlorate.

Powder these to the consistency of face powder (400 mesh) and heat gently to drive off all moisture. Melt five parts vasoline and five parts wax. Dissolve this in white gasoline (camp stove gasoline) and pour this liquid on 90 parts potassium chlorate (the crystals from the above operation) in a plastic bowl. Knead this liquid into the potassium chlorate until immediately mixed. Allow all the gasoline to evaporate. Place this explosive in a cool, dry place. Avoid friction, sulfur, sulfide, and phosphorous compounds.

This explosive is best molded to the desired shape and density (1.3g./cc.) and dipped in wax to water proof. These block type charges guarantee the highest detonation velocity. This explosive is really not suited to use in shaped charge applications due to its relatively low detonation velocity. It is comparable to 40% ammonia dynamite and can be considered the same for the sake of charge computation.

If the potassium chlorate is bought and not made it is put into the manufacture process in the powdering stages preceding the addition of the wax/vaseline mixture. This explosive is brisant and powerful. The addition of 2-3% aluminum powder increases its blast effect. Detonation velocity is 3300 m/sec..

Plastique Explosives From Swimming Pool Chlorinating Compound By the Lich

This explosive is a chlorate explosive from bleach. This method of production of potassium or sodium chlorate is easier and yields a more pure product than does the plastique explosive from bleach process.

In this reaction the H.T.H. (calcium hypochlorite  $\text{CaCl}_2$ ) is mixed with water and heated with either sodium chloride (table salt, rock salt) or potassium chloride (salt substitute). The latter of these salts is the salt of choice due to the easy crystalization of the potassium chlorate.

This mixture will need to be boiled to ensure complete reaction of the ingredients. Obtain some H.T.H. swimming pool chlorination compound or equivalent (usually 65% calcium hypochlorite). As with the bleach process mentioned earlier the reaction described below is also a dissociation reaction. In a large pyrex glass or enameled steel container place 1200g. H.T.H. and 220g. potassium chloride or 159g. sodium chloride. Add enough boiling water to dissolve the powder and boil this solution. A chalky substance (calcium chloride) will be formed. When the formation of this chalky substance is no longer formed the solution is filtered while boiling hot. If potassium chloride was used potassium chlorate will be formed.

This potassium chlorate will drop out or crystalize as the clear liquid left after filtering cools. These crystals are filtered out when the solution reaches room temperature. If the sodium chloride salt was used this clear filtrate (clear liquid after filtration) will need to have all water evaporated. This will leave crystals which should be saved.

These crystals should be heated in a slightly warm oven in a pyrex dish to drive off all traces of water (40-75 deg. C.). These crystals are ground to a very fine powder (400 mesh).

If the sodium chloride salt is used in the initial step the crystalization is much more time consuming. The potassium chloride is the salt to use as the resulting product will crystalize out of the solution as it cools. The powdered and completely dry chlorate crystals are kneaded together with vaseline in a plastic bowl. ALL CHLORATE BASED EXPLOSIVES ARE SENSITIVE TO FRICTION AND SHOCK AND THESE SHOULD BE AVOIDED. If sodium chloride is used in this explosive it will have a tendency to cake and has a slightly lower detonation velocity.

This explosive is composed of the following:

potassium/sodium chlorate 90%  
vaseline 10%

Simply pour the powder into a plastic baggy and knead in the vaseline carefully. this explosive (especially if the Sodium Chlorate variation is used) should not be exposed to water or moisture.

The detonation velocity can be raised to a slight extent by the addition of 2-3% aluminum substituted for 2-3% of the vaseline. This addition of this aluminum will give the explosive a bright flash if set off at night which will ruin night vision for a short while. The detonation velocity of this explosive is approximately 3200 m/sec. for the potassium salt and 2900 m/sec. for the sodium salt based explosive.

Addendum 4/12/91:

It was claimed above that this explosive degrades over time. I would assume that this occurs due to the small amount of water present in the vaseline, and that a different type of fuel would be better than the vaseline.

Revenge: Don't get mad - Get even      By George Hayduke

subtitled: Fun Things To Do      Written by The Ghost  
SPEED DEMON 415/522-3074 24 HOURS

This is from a book by George Hayduke. It describes a variety of ways to get back at people who cause you distress. The book has contains a lot of tips on causing expensive damage to "marks". Well, I picked the good ones. Ones that don't cause a lot of expense, in currency that is. Well, I hope you enjoy. Get back at the losers using the system. Sort of like piracy and phreaking.

In a car with automatic transmission, switch the #1 and #8 wires on the distributor cap. This will allegedly allow the car to operate in Neutral and Park, but the engine mysteriously dies in Drive.

Castor Oil squirted into the tailpipe of a car, will cause a large amount of smoke. Just the thing to help nervous drivers.

If you can get a bank account number for a person, truly wonderful things can happen. Depositing one penny every day can get the employees very pissed. It happens that given a few hundred wanted posters, one will look like you. OR anybody else you can imagine. Close anyway. Think of all the bounty hunters just waiting to claim their reward.

Place an ad in a paper for Male Secretarys only. \$11 an hour, must be physically attractive, gentle, and other related social traits. This is for anybody who has an office. Give the time to show up one half hour before the normal opening hour. For example, if the office opens at 9:00, put the time to be 8:30. All these faggots will show up and start bitching at each other and your loser.

Run an ad in the local paper with the following message.  
"I need all used christmas trees. Please leave them on my lawn, and I'll pay \$5 for each one." then leave the losers address. The paper will take your \$ and print the ad without thinking.

If you know the guy is going to throw a party, arrange for him to find out that somebody was going to crash his party, dressed up like cops. Then call the cops telling them of a real rowdy party going on.

If your college uses computers to handle admissions, try this. Fill out course withdrawl forms in the losers name. Then enter them, they probably won't check. The guy will go the entire block unknowing, then when grades are posted. "Where are mine?" "Why didn't I get grades?"

Call your colleges administration, tell them you are the undertaker of your losers hometown. He just died, please take him off your records, records will follow. Then call the parents. He just died in a fraternity accident. This will work better if the guy decides to skip a week or so of classes.

Instead of credit card fraud, just call up the company and tell them that you just lost your cards. You name? Why it's (insert loser)

If you want, advertise the losers phone number as a Dial A Joke. For bigots, Dial A Black, etc.

If you dislike a fast food place with a drive thru, try this. Order everything you can think of. Then just don't go to the window. Do it during dinner hours. Or, order a normal sized meal, but with extra helpings of mustard. Then the next car will try the food, then freak out at the joint.

Garage door openers often have dip switches that can be changed to other combinations. The cheaper the model, the better. Sears sells just the unit. Say you broke yours or something. Then change the settings.

Wax crayons tossed into a wash do wonders to whites or anything else.

There is a whole section of phun things to do with a phone. Call in a bomb threat to a school or something, then leave the handset offhook. Of course, do this only at the losers house. Someone will visit.

Ads placed in papers saying that (insert loser) will sell YOU! the plans to a device enabling inexpensive calls. Mention that you keep no records. If you are getting back at somebody with a multi-line system, this is good.

If you can get a private minute with your marks phone, and the handset is modular, cover the handset plug with clear nail polish. The phone rings, then its unlimited "Hello?" "Hello?"

Remove the pins from all but one of the hinges of a front door of a business. The door will work fine, for a while, then fall off. People start screaming.

Add luminescent paint into the cans of someone who is painting their fence. Then, at night, it glows.

Get some copper paint and paint a small line across the insulator of a spark plug in a car. They'll never find it.

If your loser gets a parking ticket, get it before he sees it. Then get a stamp flicking the cops off. Send it in with no money.

If you dislike a pet hater, here's one. Advertise that you(the loser) would like to buy all unwanted strays. \$10 for each one. Then call the SPCA, telling them that the loser wants the animals to conduct black masses and pagan rites.

Laxatives slipped into dogfood does wonders.

Or better yet, toss some normal meat into the dog-owners yard. Then call him up(in a disguised voice) and tell him you saw a suspicious person hanging around the yard....

Mail a letter to the Chief Executive detailing the sexual acts you would like to commit, the Secret Service investigates this with no humor.

PA systems in department stores are great. Just walk up to a deserted unit, look around, then deliver the most disgusting statement you can think of.

Call about thirty people, telling them they just won a sweepstakes. Answer the questions, no obligation, it's just to show how generous people are. Then give the losers phone number to call for more info.

Remember two things, hot metal and hot glass do not look different from cool. (as long as it's not too hot)

Western Telegram has a check on everything going through. Certain key words trip alarms. Guns, Drugs, Sex, Terrorist, etc all ring bells. Have fun

There are many ways to thrash someones car. But they basicly fall under 2 topics. These are, 1 to just fuck it up and 2, to distroy it. As long as your at it don't for get to steal the stero & speakers.

#### Sweet-Gas

This involves taking the gas cap off of you victims car. If it is a locking cap break it off. Or you might pry it off. Once you have the gas cap off pour 4 or 5 pounds of white sugar in there gas tank. Now when the start there

car up and drive away they will go about 2 miles or so then the car will crap out and they will have to pay some \$'s to get it fixed.

Addendum 4/12/91: This does NOT work- try confectioner's sugar, it might.

#### Sweet-Oil

In this one you open there hood and pour some honey in their oil spout. if you have time you might remover the oil plug first and drain some of the oil out. I have tried this one but wasn't around to see the effects but I am sure that I did some damage.

#### Slow Air

Ok, sneak up the victums car and poke a small hole somewhere in 2 of his/her tires. They only have 1 spare. Now if the hole is small but there then there tire will go flat some where on the road. You could slice the tire so this is blows out on the road wih a razor blade. Cut a long and fairly deep (don't cut a hole) and peel a little bit of the rubber back and cut that off. Now very soon there tires will go flat or a possible blow out at a high speed if your lucky.

#### Vanishing Paint

Spread a little gas or paint thiner on the victims car and this will make his paint run and fade. Vodka will eat the paint off and so will a little 190. Eggs work great on paint if they sit there long enough.

#### Loose Wheel

Loosen the lugs on you victums tires so that they will soon fall off. This can really fuck some one up if they are cruising when the tire falls off.

No name for this one. but where you pour oil into the engine, pour some sand, this will scar the head and pushrodes and possible scrach the fuck out of the cylinder.

### Dual Neutral

This name sucks but pull the 10 bolt or what ever they have there off. (On the real wheels, in the middle of the axle) Now throw some screws, bolts, nuts and assorted things in there and replace the cover. At this point you could chip some of the teeth off the gears.

### Un-Midaser

Crawl under there car with a ratchet and losen all the nuts on their exhaust so that it hangs low and will fall off soon. This method also works on transmissions but is a little harder to get all bolts off, but the harder you work the more you fuck them over.

A quickie bomb, stolen from MacGyver

-----  
Typed, Uploaded, and Translated by

(\_> Shadow Hawk 1 <\_)

Ok. Heres a really simple bomb that you can make from things you've probably got lying around the house... What you ne eed:

A bag of fertilizer

Some Cotton

Some Starter Fluid (etherous kind)

Some Newspaper

Ok... You fold the newspaper until its in sort of a pocket shape, then fill it up with fertilizer (not too much).. Next, you put cotton on top of the fertilizer. Then, pour some starter fluid on it (the fertilizer), wrap up the newspaper (you can use tape). Now this isnt the kind of bomb you leave lying around for a couple days, as it drys out. When you want to use it, just light the edge of the newspaper and throw it. Pretty simple, eh?

Addendum 4/12/91: This is stupid. Starting fluid is DANGEROUS stuff. Try it if you like, but I recommend a better detonation technique than burning newspaper... Maybe a spark plug?

P.S. I never noticed before, but all the formulas, etc. that the dude on macgyver uses are real, (i checked quite a few of em). (c) 1986 The J-Men

## How To Make Mercury Fulminate by The Lockpic & The Blitz

When employing the use of any high explosive, an individual must also use some kind of detonating device. Blasting caps are probably the most popular today, since they are very functional and relatively stable. The prime ingredient in most blasting caps and detonating devices in general is mercury fulminate. There are several methods for preparing mercury fulminate.

1. Take 5 grams of pure mercury and mix it with 35 ml. of nitric acid.
2. The mixture is slowly and gently heated. As soon as the solution bubbles and turns green, one knows that the silver mercury is dissolved.
3. After it is dissolved, the solution should be poured, slowly, into a small flask of ethyl alcohol. This will result in red fumes.
4. After a half hour or so, the red fumes will turn white, indicating that the process is nearing its final stage.
5. After a few minutes, add distilled water to the solution.
6. The entire solution is now filtered, in order to obtain the small white crystals. These crystals are pure mercury fulminate, but should be washed many times, and tested with litmus paper for any remaining undesirable acid.

### Method No. 2

1. Mix one part mercuric oxide with ten parts ammonia solution. When ratios are described, they are always done according to weight rather than volume.
2. After waiting eight to ten days, one will see that the mercuric oxide has reacted with the ammonia solution to produce the white fulminate crystals.
3. These crystals must be handled in the same way as the first method described, in that they must be washed many times and given several litmus paper tests.

Many other fulminates can be made, however most are extremely unstable and sensitive to shock. All fulminates including mercury fulminate, are sensitive to shock and friction, and in no circumstances should they be handled in a rough or careless manner..

Call these Commodore X-changes

The headquarters (817)430-8239  
T.A.R.G.E.T. (817)295-9228  
Pirates Exchange (214)446-2219  
(C) Hang Ten '86

How to Make Ammonium Nitrate from THE POOR MAN'S JAMES BOND by: Kurt Saxon  
TYPED BY THE REFLEX

Disclaimer:

I, THE REFLEX, will accept full responsibility for any damage caused by information obtained from this text-file. As a matter of fact, I'll let you sue me and I'll pay. All you have to do is tell your lawyer, "It's all THE REFLEX's fault." I'll see you when you get out of the institution.

Some Militants who don't have much dynamite use ammonium nitrate. This can be bought by anyone at \$3.75 for and 80 pound bag. It is fertilizer.

Ammonium nitrate explodes at rates up to 14,000 feet per second. It is roughly compared to dynamite having 60% nitro.

The fertilizer grade Militants use is mixed with motor oil at the ratio of one pint of oil to 8-1/2 pounds of ammonium nitrate. This has to be detonated with a stick of gelatin dynamite [I didn't say all was easy. Try to find another file about that crap.].

Purified ammonium nitrate can be detonated with a number six dynamite cap. The pure stuff can be bought at chemical supply houses or the fertilizer grade can be purified with distilled wood alcohol.

Put several pounds of fertilizer grade ammonium nitrate in a pan. Pour in enough wood alcohol (methanol) to cover the fertilizer. Then stir it until a lot of it has dissolved. Next, let it set for a few minutes to allow the impurities to settle to the bottom along with the undissolved ammonium nitrate.

Another pan is set on some pieces of dry ice for the next step. Dry ice can be found in the business section of the phone book under "Dry Ice." Locker companies will sell it to anyone, cheaply and in small amounts.

The dissolved ammonium nitrate is poured into the cold pan. This is done carefully so as to leave the impurities and undissolved ammonium nitrate behind.

The dry ice causes the purified ammonium nitrate to precipitate out of the solution in crystals. When no more crystals are formed they are removed from the alcohol.

The alcohol is then poured back into the other pan and stirred to dissolve any ammonium nitrate left undissolved. After setting a few minutes the solution is again poured off the dregs and the dregs are thrown away. When the last batch of crystals is removed, the alcohol can be stored and reused.

The dry ice is simply frozen carbon dioxide and its fumes are harmless unless they are enough to replace the air. Don't handle the dry ice with your bare hands [unless you are into pulling your skin off to the bone] as its cold will cause blisters.

In order for pure ammonium nitrate to be detonated by a dynamite cap, it must be very dry. Spread it out under a heat lamp or in the sun. When completely dry, store it in tightly closed plastic bags.



flat window screening, 1 ft. sq.	heat source
water, 3 cups	alcohol, 5 pints (any kind)
sulfer, powdered, 1/2 cup (flowers of sulfer, at a drug store)	wood charcoal, powdered, 2 cups
2 buckets, both 2 gallon, one must be heat resistant	potassium nitrate, granulatd, 3 cups (saltpeter, at drug stores)

PROCEDURE:

1. PLACE ALCOHOL IN ONE OF THE BUCKETS.
2. PLACE POTASSIUM NITRATE, CHARCOAL, AND SULFUR IN THE HEAT RESISTANT BUCKET. ADD 1 CUP WATER AND MIX THOROUGHLY WITH WOODEN STICK UNTIL ALL INGREDIENTS ARE DISSOLVED.
3. ADD REMAINING WATER (2 CUPS) TO MIXTURE. PLACE BUCKET ON HEAT SOURCE AND STIR UNTIL SMALL BUBBLES BEGIN TO FORM.

CAUTION: DO NOT BOIL MIXTURE. BE SURE ALL MIXTURE STAYS WET. IF ANY IS DRY, AS ON SIDES OF PAN, IT MAY IGNITE.

4. REMOVE BUCKET FROM HEAT AND POUR MIXTURE INTO ALCOHOL WHILE STIRRING VIGOROUSLY.
5. LET ALCOHOL MIXTURE STAND ABOUT 5 MINUTES. STRAIN MIXTURE THROUGH CLOTH TO OBTAIN BLACK POWDER. DISCARD LIQUID. WRAP CLOTH AROUND BLACK POWDER AND SQUEEZE TO REMOVE ALL EXCESS LIQUID.
6. PLACE SCREENING OVER DRY BUCKET. PLACE WORKABLE AMOUNT OF DAMP POWDER ON SCREEN AND GRANULATE BY RUBBING SOLID THROUGH SCREEN.

NOTE: IF GRANULATED PARTICLES APPEAR TO STICK TOGETHER AND CHANGE SHAPE, RECOMBINE ENTIRE BATCH OF POWDER AND REPEAT STEPS 5 AND 6.

7. SPREAD GRANULATED BLACK POWDER ON FLAT DRY SURFACE SO THAT LAYER ABOUT 1/2 INCH IS FORMED. ALLOW TO DRY. USE RADIATOR, OR DIRECT SUNLIGHT. THIS SHOULD BE DRIED AS SOON AS POSSIBLE, PREFERABLY IN ONE HOUR. THE LONGER THE DRYING PERIOD, THE LESS EFFECTIVE THE BLACK POWDER.

CAUTION: REMOVE FROM HEAT AS SOON AS GRANULES ARE DRY. BLACK POWDER IS NOW READY FOR USE!

## EXPEDIENT GRENADES The Cheshire Cat

There are many possibilities in the field of grenade manufacture, but for the most part, when you're dealing with grenades that must be constructed of easily available materials, the quality and the safety of the grenade is reduced dramatically.

Here I will deal with this problem, trying to produce a reasonable type of grenade that is relatively safe, can be stored and transported easily, but produces dramatic effects. I strongly suggest that if you find it possible, you are far better off getting a REAL grenade than trying to produce one yourself, but you can be the judge. As always, I want to note that this is all for educational purposes only, and I do not recommend anyone trying any of the following for real.

The first thing you need is explosives. If you can't get black powder, or gun powder, or make your own plastic explosives (we know there sure are enough text files floating around to explain how to make all of the above!) than you're really in a for making a grenade of this type.

You'll also need a coffee can, a smaller sized can (probably like an orange juice can, or V8), a coat hanger, and a fuse. As for explosives, mercury fulminate is extremely good for this sort of thing.

You could probably get together a ton of firecrackers and take out the black powder (if you're desperate) or get a couple quarter sticks from someone. The explosive goes in the juice can. Don't pack it together too tight. Loose black powder is better than compressed. This is the main explosive.

Cut up the coat hanger into little pieces approximately 1/2" long and fill up the coffee can until you can put the juice can in and the top of the juice can is level with the top of the coffee can. If you don't have the time, and need to fill up the space faster, chuck in a couple small rocks or pieces of glass, and stuff like that until you have the bottom of the can filled.

Now place the juice can in the coffee can, and center it. Then fill the space around the coffee can with coat hanger stuff until the juice can is relatively stable. Put a model rocket fuse in the explosive in the juice can. Leave (at least) 3 1/2" to light from. If necessary, secure the juice can or the explosive with some masking tape, ect... as long as it doesn't interfere with the action of the grenade.

Take the lid of the coffee can and cut a hole so that the fuse is exposed. You now have a fragmentation grenade. It might be a good idea to practice with a football for a while before trying to destroy the neighbor's garage with it.

try OSB systems (215)-395-1291 an awesome AE/BBS. Later, The Cheshire Cat

## How to Counterfeit

Written by The Wave

This article deals with how to make counterfeit money. Before reading this article it would be a very good idea to get a book about photo-offset printing, for that's how you'll have to print it. For someone who is familiar with offset printing, printing money is a breeze. Real money is made by a process called gravure. It involves carving out of a metal block (but I don't think anyone can do that by hand-if you can, you should be on That's Incredible!). When you are done (if you did everything correctly) you will have a finished product nearly identical to real money, depending on your printing skills. Well, let's get started!

First I'd like to tell you briefly how offset printing works. It starts by making negatives (kind of like when you take a picture with your camera). Then you take the negatives and put them on a piece of masking material (usually orange). Then you expose the STRIPPED negatives or FLATS to a lithographic plate with an arc light plate maker. The BURNED plates are then developed with the proper developer chemical. These plates (one at a time of course) are wrapped around the plate cylinder of the press. The press to use should be an 11 by 14 (or so) offset such as the 11 by 17 AB Dick 360. Then the printing begins! To learn in detail how to do each of these steps you should again get a book on the subject. The presswork takes some practice, but you'll get the hang of it.

BTW you can

pick up an 11 by 14 offset for about \$500 if you shop around (or you can \*\*BORROW\*\* a press from your local Insty Prints at about 3:00 in the morning!). First, like I said before, you need negatives. Make 2 negatives of the portrait side of the bill and 1 of the back side. After developing them and letting them dry, take them to a light table. Get some opaque and, on one of the portrait sides, touch out all the green (the seal and the serial numbers). Line that one up on the FLAT and leave about 1/2 inch from the top of the flat. Then for the other portrait, touch out everything BUT the seal and serial numbers. The back side doesn't require any retouching because it is all one color.

Now, make sure all the negatives are lined up right, or REGISTERED, on the flats. By the way, every time you need another serial number, just shoot 1 neg. of the portrait side and cut out the serial number. Cut out the old serial number from the flat and replace it with the new one. Ok, now you have 3 flats, each represents a different color-black and 2 shades of green (which of course are made by mixing inks). Now you are ready to burn the plates. Take a lithographic plate and mark 3 marks on it. These marks must be 2 & 9/16 in. apart, starting on one of the short edges.

Do the same thing to 2 more plates. Then take 1 of the flats and place it on the plate, lining the short edge up with the edge of the plate-EXACTLY! Burn it, move it up to the next mark, and cover up the exposed area you already burned. Burn that and do the same thing 2 more times-moving the flat up one mark. Then do the same process with the other 2 flats (each on a separate plate). Develop all 3 plates. You should have 4 images on each plate with an equal space between each bill.

## Roll the Presses!

The paper you will need won't match exactly, but you can make it pretty damn close (close enough for the cashier at K-Mart!). The paper to use should have a 25% rag content. I have found that Disaperf computer paper works great - that's the kind that you can barely see the perforation. Take this paper (cut the pinfeed holes off first!) and load it into the press. Be sure to set the air, buckle, and paper thickness right.

Start with the black plate (the one with out the serial numbers). Wrap it around the cylinder and load black ink in. Make sure you run more than you need because there will be a lot of rejects. Then, while that's printing, mix the inks for the serial #'s and the back side. You'll need to add some white and maybe yellow to the serial # ink. You need to add black to back side. Experiment till you get it right. Clean the press and print the other side. Now you have the bill with no green seal or serial numbers. Print a few with one serial number, make another and repeat. Keep doing this until you have as many different numbers as you want.

Then cut the bills to the exact size with a paper cutter Now you have a lot of money, except there is still one problemo - the paper is pure white. To dye it, mix the following in a pan: 2 cups hot water, 4 tea bags, and about 16-20 drops of green food coloring (experiment). Dip one of The bills in and compare it to a brand new REAL bill. Make the necessary adjustments, and dye all the bills. Then it is a good idea to make them look used. Wrinkle them, rub coffee grinds on them, etc. Congratulations! You're rich!

Some of the info was taken from The Poor Man's James Bond, but most from personal knowledge. Also, it would be a good idea to see the movie To Live and Die in L.A. It is about a counterfeiter and they did a good job of showing how to do it. Well, that's all folks!

Call the Shadowkeep AE (513) 832-1938 AE:TAC

Addendum 4/12/91:

I have heard that there are several methods of detecting CONTERFEIT money. First, most green ink flouresces under UV light. Second, some money verifiers sold use MAGNETIC ink and INFRARED detection to tell if the money is real.

I do NOT know what the pattern used is, if anybody does, send E-mail.

HOMEMADE GUNS from "The Poor Man's James Bond"

### PIPE OR "ZIP" GUNS

Commonly known as "zip" guns, guns made from pipe have been used for years by juvenile punks. Today's Militants make them just for the hell of it or to shoot once in an assassination or riot and throw away if there is any danger of apprehension.

They can be used many times but with some, a length of dowel is needed to force out the spent shell.

There are many variations but the illustration shows the basic design.

First, a wooden stock is made and a groove is cut for the barrel to rest in. The barrel is then taped securely to the stock with a good, strong tape.

The trigger is made from galvanized tin. A slot is punched in the trigger flap to hold a roofing nail, which is wired or soldered onto the flap. The trigger is bent and nailed to the stock on both sides.

The pipe is a short length of one-quarter inch steel gas or water pipe with a bore that fits in a cartridge, yet keeps the cartridge rim from passing through the pipe.

The cartridge is put in the pipe and the cap, with a hole bored through it, is screwed on. Then the trigger is slowly released to let the nail pass through the hole and rest on the primer.

To fire, the trigger is pulled back with the left hand and held back with the thumb of the right hand. The gun is then aimed and the thumb releases the trigger and the thing actually fires.

Pipes of different lengths and diameters are found in any hardware store. All caliber bullets, from the .22 to the .45 are used in such guns.

Some zip guns are made from two or three pipes nested within each other. For instance, a .22 shell will fit snugly into a length of a car's copper gas line. Unfortunately, the copper is too weak to withstand the pressure of the firing. So the length of gas line is spread with glue and pushed into a wider length of pipe. This is spread with glue and pushed into a length of steel pipe with threads and a cap.

Using this method, you can accommodate any cartridge, even a rifle shell. The first size of pipe for a rifle shell accommodates the bullet. The second accommodates its wider powder chamber.

A 12-gauge shotgun can be made from a 3/4 inch steel pipe. If you want to comply with the gun laws, the barrel should be at least eighteen inches long.

Its firing mechanism is the same as that for the pistol. It naturally has a longer stock and its handle is lengthened into a rifle butt. Also, a small nail is driven half way into each side of the stock about four inches in the front of the trigger. The rubber band is put over one nail and brought around the trigger and snagged over the other nail.

In case you actually make a zip gun, you should test it before firing it by hand. This is done by first tying the gun to a tree or post, pointed to where it will do no damage. Then a string is tied to the trigger and you go off several yards. The string is then pulled back and let go. If the barrel does not blow up, the gun is (probably) safe to fire by hand.

Astrolite and Sodium Chlorate Explosives By: Future Spy & The Fighting Falcon

Note: Information on the Astrolite Explosives were taken from the book  
'Two Component High Explosive Mixtures' By Desert Pub'l

Some of the chemicals used are somewhat toxic, but who gives a fuck! Go ahead! I won't even bother mentioning 'This information is for enlightening purposes only!' I would love it if everyone made a gallon of astrolite and blew their fucking school to kingdom scum!

#### Astrolite

The astrolite family of liquid explosives were products of rocket propellant research in the '60's. Astrolite A-1-5 is supposed to be the world's most powerful non-nuclear explosive -at about 1.8 to 2 times more powerful than TNT. Being more powerful it is also safer to handle than TNT (not that it isn't safe in the first place) and Nitroglycerin.

#### Astrolite G

"Astrolite G is a clear liquid explosive especially designed to produce very high detonation velocity, 8,600MPS (meters/sec.), compared with 7,700MPS for nitroglycerin and 6,900MPS for TNT...In addition, a very unusual characteristic is that it the liquid explosive has the ability to be absorbed easily into the ground while remaining detonatable...In field tests, Astrolite G has remained detonatable for 4 days in the ground, even when the soil was soaked due to rainy weather" know what that means?...Astrolite Dynamite!

To make (mix in fairly large container & outside)

Two parts by weight of ammonium nitrate mixed with one part by weight 'anhydrous' hydrazine, produces Astrolite G...Simple enough eh? I'm sure that the 2:1 ratio is not perfect, and that if you screw around with it long enough, that you'll find a better formula. Also, dunno why the book says 'anhydrous' hydrazine, hydrazine is already anhydrous...

Hydrazine is the chemical you'll probably have the hardest time getting hold of. Uses for Hydrazine are: Rocket fuel, agricultural chemicals (maleic hydra-zide), drugs (antibacterial and antihypertension), polymerization catalyst, plating metals on glass and plastics, solder fluxes, photographic developers, diving equipment. Hydrazine is also the chemical you should be careful with.

#### Astrolite A/A-1-5

Mix 20% (weight) aluminum powder to the ammonium nitrate, and then mix with hydrazine. The aluminum powder should be 100 mesh or finer. Astrolite A has a detonation velocity of 7,800MPS.

#### Misc. info

You should be careful not to get any of the astrolite on you, if it happens though, you should flush the area with water. Astrolite A&G both should be able to be detonated by a #8 blasting cap.

### Sodium Chlorate Formulas

Sodium Chlorate is similar to potassium chlorate, and in most cases can be a substitute. Sodium chlorate is also more soluble in water. You can find sodium chlorate at Channel or any hardware/home improvement store. It is used in blowtorches and you can get about 3lbs for about \$6.00.

### Sodium Chlorate Gunpowder

65% sodium chlorate, 22% charcoal, 13% sulfur, sprinkle some graphite on top.

### Rocket Fuel

6 parts sodium chlorate mixed \*THOROUGHLY\* with 5 parts rubber cement.

### Rocket Fuel 2 (better performance)

50% sodium chlorate, 35% rubber cement ('One-Coat' brand),  
10% epoxy resin hardener, 5% sulfur

You may want to add more sodium chlorate depending on the purity you are using.

### Incendiary Mixture

55% aluminum powder (atomized), 45% sodium chlorate, 5% sulfur

### Impact Mixture

50% red phosphorus, 50% sodium chlorate

Unlike potassium chlorate, sodium chlorate won't explode spontaneously when mixed with phosphorus. It has to be hit to be detonated.

### Filler explosive

85% sodium chlorate, 10% vaseline, 5% aluminum powder

### Nitromethane formulas

I thought that I might add this in since it's similar to Astrolite.

Nitromethane (CH3NO2)                      specific gravity:1.139  
flash point:95f                              auto-ignite:785f

Derivation: reaction of methane or propane with nitric acid under pressure.  
Uses:            Rocket fuel; solvent for cellulosic compounds, polymers, waxes,  
fats, etc.

To be detonated with a #8 cap, add:

- 1) 95% nitromethane + 5% ethylenediamine
- 2) 94% nitromethane + 6% aniline

Power output: 22-24% more powerful than TNT. Detonation velocity of 6,200MPS.

### Nitromethane 'solid' explosives

2 parts nitromethane, 5 parts ammonium nitrate (solid powder)

soak for 3-5 min. when done, store in an air-tight container. This is  
supposed to be 30% more powerful than dynamite containing 60% nitro-glycerin,  
and has 30% more brilliance.

### The Firey Explosive Pen    Written by Blue Max of Anarchist-R-Us

#### Materials Needed

- 1] One Ball Point `Click` pen
- 2] Gun Powder
- 3] 8 or 10 match heads
- 4] 1 Match stick
- 5] a sheet of sand paper (1 1/2" X 2")

Here's a GREAT little trick to play on  
your best fiend (no thats not a typo) at  
skool, or maybe as a practical joke on a  
friend!

- 1] Unscrew pen and remove all parts but leave the button in the top.
- 2] Stick the match stick in the part of the pen clicker where the other little  
parts and the ink fill was.
- 3] Roll sand paper up and put around the match stick that is in the clicker.
- 4] Put the remaining Match Heads inside the pen, make sure that they are on  
the inside on the sand paper.
- 5] Put a small piece of paper or something in the other end of the pen where  
the ball point comes out.
- 6] Fill the end with the piece of paper in it with gun powder. The paper is  
to keep the powder from spilling.

The Finished pen should look like this:

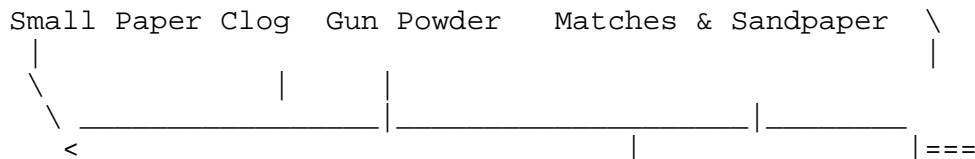

## HOW TO BLOW UP A CAR: A different way

by THE FLYING HERMIT

There are times in a man's life when he gets mad at someone. And then there are times when he gets REAL mad at someone. These are the times for vengeance. And what better way to get back at someone than damaging his/her car. The thing which s/he has saved up for, worked hard for, and paid for.

Yes!!! This is the item which you must attack, for most of the time, it is parked outside, easily accesible at night and very important to the asshole you want to annoy. The method I will describe is relatively easy and safe to set up, but very effective in causing damage. The method of destruction will be explosion. The explosive device is already inside the car, factory installed just for you to use. It is the standard 12 volt car battery.

Let's look at the princple behind the exploding battery:

You are by now familiar with the theory of how batteries work, and if you aren't, your probably too young to be thinking of these sorts of things. Anyway, within the battery, is not only a current flowing from positive to negative (actually, it is from negative to positive, but that's another story), but also a small internal resistance. The resistance inside the battery is in the order of magnitude of roughly .0024 OHM, an amount so small, it is usually ignored. But, that is for normal operation of the battery. The case we're interested in is for the closed circuit of the battery by itself. For a closed circuit, the internal resistance becomes a big deal, and the following holds true:

$$12\text{volt}/.0024 \text{ ohm} = 5000 \text{ amps}$$

Amazing!!!! by causing a short circuit (closed circuit), the battery produces 5000 amps of current running through that little bugger. However, this current is short lived, and the battery cannot handle this capacity for long, so therefore the battery explodes. It explodes with a rather large force, causing considerable damage from the pressure, flames, and hurling lead. All these goodies combined with the volatile liquids hidden inside the engine will cause the vehicle to add another member to the big junk yard in the sky.

Great!! now we know how to make the car blow up, but we don't want to go up with hte car, so what we need is a triggering device. one can go from the simple to elaborate, by incorporating sophisticated devices such as radio transmitters, but for our purposes, we will opt for a simple timer and relay device.

First, we will need some heavy cable, capable of handling the massive current without melting, then we will need a relay also able to cope with large currents. Next, we need a timer which will count down the seconds to our triumphant vengeance. And finally, a small battery to run the relay (the small battery will run both the relay and the timer if you are using a digital timer).

Now: Connect the small battery to the timer, the timer to the relay, and the relay to the car battery. Connect the heavy duty relay to the the car battery with the heavy cable. There you have it!!!!

remember, tinkering with other people's property is a no-no, and officer friendly might get ugly with you if he sees you doing this, so be forewarned. Also, car batteries are dangerous to play with, and if handled improperly, may explode unintentionally, causing the concentrated acid to spray in your face, making you look like the elephant man. so don't come crying to me when something happens, cause i'll just laugh at you and possibly urinate over you if you rub me the wrong way.

call the RIPCO bulletin board, 'a hell of a bbs' at (312) 528-5020

MERCURY BATTERY BOMB! By Phucked Agent!

Materials:

1 Mercury Battery (1.5 or 1.4 V Hearing Aid), 1 working lamp with on/off switch

It is VERY SIMPLE!!! Hurray! Kids under 18 shouldn't considered try this one or else they would have mercuric acid on their faces!

1. Turn the lamp switch on to see if lite-bulb light up.
2. If work, leave the switch on and unplug the cord
3. Unscrew the bulb (Dont touch the hot-spot!)
4. Place 1 Mercury Battery in the socket and make sure that it is touching the Hot-spot contact.
5. Move any object or furniture - Why? There may be sparx given off!
6. Now your favorite part, stand back and plug in cord in the socket.
7. And you will have fun!! Like Real Party!!!

If your house is on fire (VERY RARE), get that damm fire blower! This stuph will NOT destroy your plugs, but maybe the fuse depending how often you do that.... Best try outside or college dorm... <eof>

TRY SKIDD'S LAB BBS 312-631-5256

A milk carton bomb is relatively simple and safe. It's only purpose is to create a loud noise.

The ingredients needed to make this are few and easy to acquire. You will need a plastic milk carton, lighter fluid (type used in cigarette lighters), a piece of paper, and a pair of chopsticks. If you can not obtain chop sticks, it's okay to substitute them with something that can hold the paper and is long enough so that you won't be harmed by the flames.

After acquiring all of the ingredients, you can now start to make the bomb. The procedure is easy. First, puncture a hole at the bottom of the milk carton with a screw driver or equivalent. Next fill one-fourth of the milk carton with lighter fluid.

Place the milk carton in a fairly large area outside. Hold a piece of paper between the chopsticks and light the paper with a match. Cautiously place the lighted paper under the hole of the carton and BOOM! You have your loud explosion with little damage to the surrounding area. It would be a good idea to have some water handy to extinguish any flames.

Be careful when doing this and have fun.