

TRAFFIC LIGHT CHANGER

IT IS A VIOLATION OF MOST STATE LAWS TO OPERATE A FLASHING / STROBE LIGHT IN OR ON YOUR VEHICLE UNLESS YOU ARE AUTHORIZED. DO NOT USE THIS DEVICE IN OR ON YOUR VEHICLE UNLESS YOU ARE AUTHORIZED. PLANS AND KITS IS NOT LIABLE FOR USE OR MISUSE.

When properly assembled, this device will allow you to change the traffic light signal to green within 2 seconds upon activation. Assembly is simple requiring only a soldering iron and wire cutters.

Parts list:

C1 .01UF MONO CAPACITOR (103)
C2-C7 33UF 100V ELECTROLYTIC CAPACITORS
C8 1UF MYLAR CAPACITOR
D1 1N4007 DIODE
F1 PIGTAIL FUSE RATED 12VDC AT 4AMPS
FT HORSESHOE XENON FLASHTUBE
L1 NEON LAMP
P1 250K-1MEG OHM POTENTIOMETER
Q1 TIP36 PNP POWER TRANSISTOR W/HEAT SINK
Q2-Q3 0500 NPN POWER TRANSISTORS W/HEAT SINKS
Q4 106 SCR
R1 1K OHM RESISTOR 1/4WATT
R2-R3 47K OHM RESISTOR 1/4WATT OR 1/2WATT (BETTER)
S1 PUSH BUTTON SWITCH
T1-T2 YELLOW INVERTER TRANSFORMERS
T3 COMMON TRIGGER COIL FOR STROBE
PCB PRINTED CIRCUIT BOARD
REFL MYLAR REFLECTOR WITH CIRCUIT BOARD BACKING

USE RESIN OR ROSIN CORE SOLDER ONLY. INSTALL SMALLEST PARTS FIRST. INSTALL THE FLASHTUBE LAST. CONNECT WIRES AND POWER CORD LAST THEN PLACE IN BOX AND MOUNT BUTTON ON TOP OF BOX.

YOU CAN USE FILTER MATERIAL AROUND THE STROBE TUBE TO BLOCK THE WHITE LIGHT AND ALLOW ONLY RED AND IR THROUGH. THIS SHOULD WORK FINE IN MOST AREAS.

TO USE THE DEVICE YOU USE ACTIVATE THE STROBE SEQUENCE AT LEAST 100 YARDS BEFORE THE LIGHT BUT 300 YARDS IS THE STANDARD DUE TO SHADE FILTERS AROUND THE TRAFFIC LIGHT SENSORS. THE SENSOR CAN ONLY "SEE" THE LIGHT FROM 200-300 YARDS IN MOST CASES. ONCE YOU ACTIVATE THE STROBE FOR A FEW SECONDS THE TRAFFIC LIGHT SHOULD NOTIFY CROSS TRAFFIC BY TURNING YELLOW THEN RED WITHIN 2 SECONDS.

THEORY OF OPERATION

The C6460 12VDC variable rate High Power Strobelight kit uses a direct coupled oscillator made up of transistors Q1, Q2 and Q3 along with capacitor C1, transformers T1, T2 and resistors R1 and R2. The purpose of the transformers is to change the low voltage AC produced by the oscillator into a high voltage AC. The output of the transformer goes to a diode D1, which is connected to capacitor bank C2-C7. As soon as the storage capacitor bank C2-C7 charges up, it powers the neon relaxation oscillator formed by R3, P1, C8, L1, Q4 and T3. Potentiometer P1 is a variable resistor which controls the frequency (or rate) of flashing. Each time the charge on C8 is sufficient to ionize L1, it causes the silicon controlled rectifier (SCR) Q4 to fire, which causes about 60 volts on C8 to be converted to 4KV by the action of the trigger coil T3. This trigger voltage causes FT1 to flash. When FT1 flashes, it discharges C8 and the cycle repeats itself.

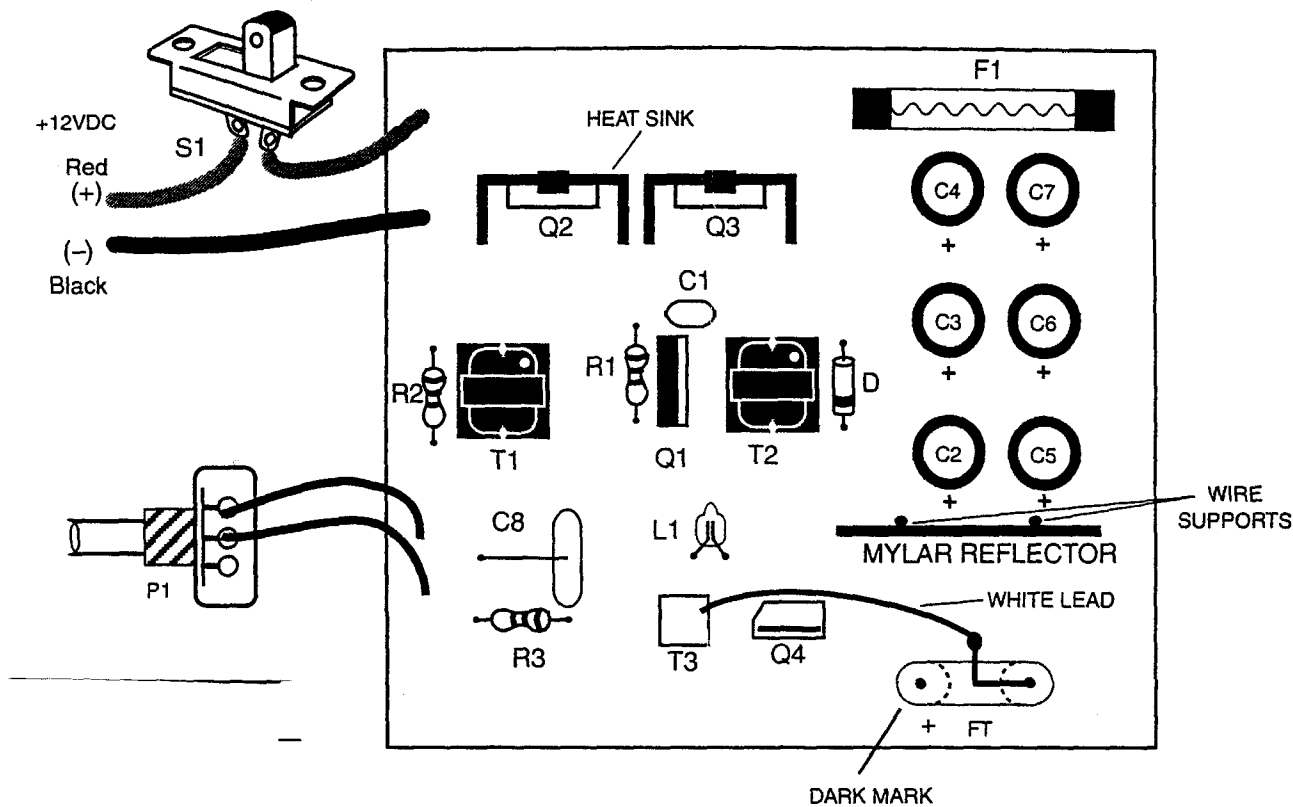
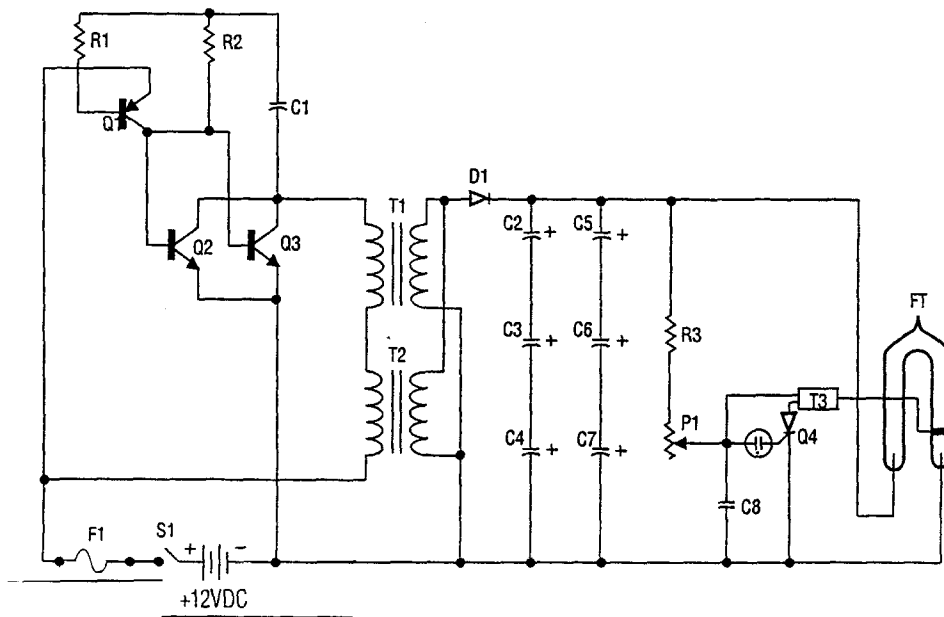

RESISTOR COLOR CODE



BAND COLOR	1st DIGIT	2nd DIGIT	MULTIPLIER
BLACK	0	0	1
BROWN	1	1	10
RED	2	2	100
ORANGE	3	3	1,000 (K)
YELLOW	4	4	10,000
GREEN	5	5	100,000
BLUE	6	6	1,000,000 (M)
VIOLET	7	7	10,000,000
GRAY	8	8	100,000,000
WHITE	9	9	1,000,000,000

*TOLERANCE: NO COLOR 20%; SILVER 10%; GOLD 5%.

TRANSISTOR/SCR INFORMATION

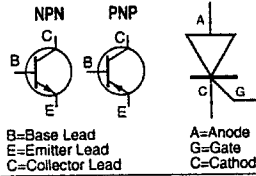

CASES

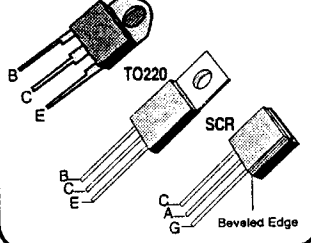

Plans And Kits Unlimited
1830-D West Vista Way #515
Vista CA 92083-6119
www.plans-kits.com

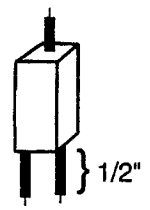

NOTE: There is no polarity to observe when installing T3 (you can ignore the white dot).

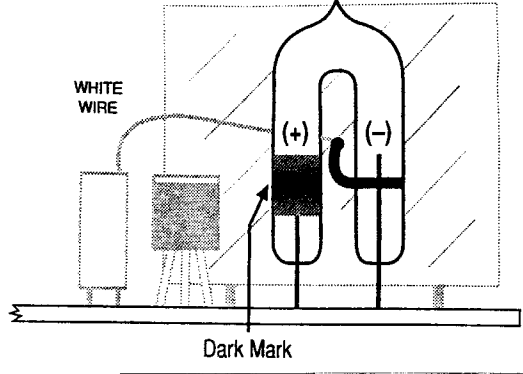

FOIL PATTERN OF PC BOARD

