

The transmitter circuit consists of WZ-X01 RF module, Holtek HT-640 encoder and 8-bit A/D converter. U1 ADC0804 converts the analog voltage to digital data; U2 encodes that data (D0~D6) along with D6, D7 and transmitting through the RF transmitter module. The potentiometer VR1 varies the voltage to the A/D U1 pin6, since only the lower 6 bits are used; the trim pot VR2 has to adjust so that the maximum input to the U1 will not exceed 1.25V. The S2 (D6) and S3 (D7) are used for controlling the rotation direction of the motors. S1 set the transmitter address; this address has to match with the address of the decoder circuit.

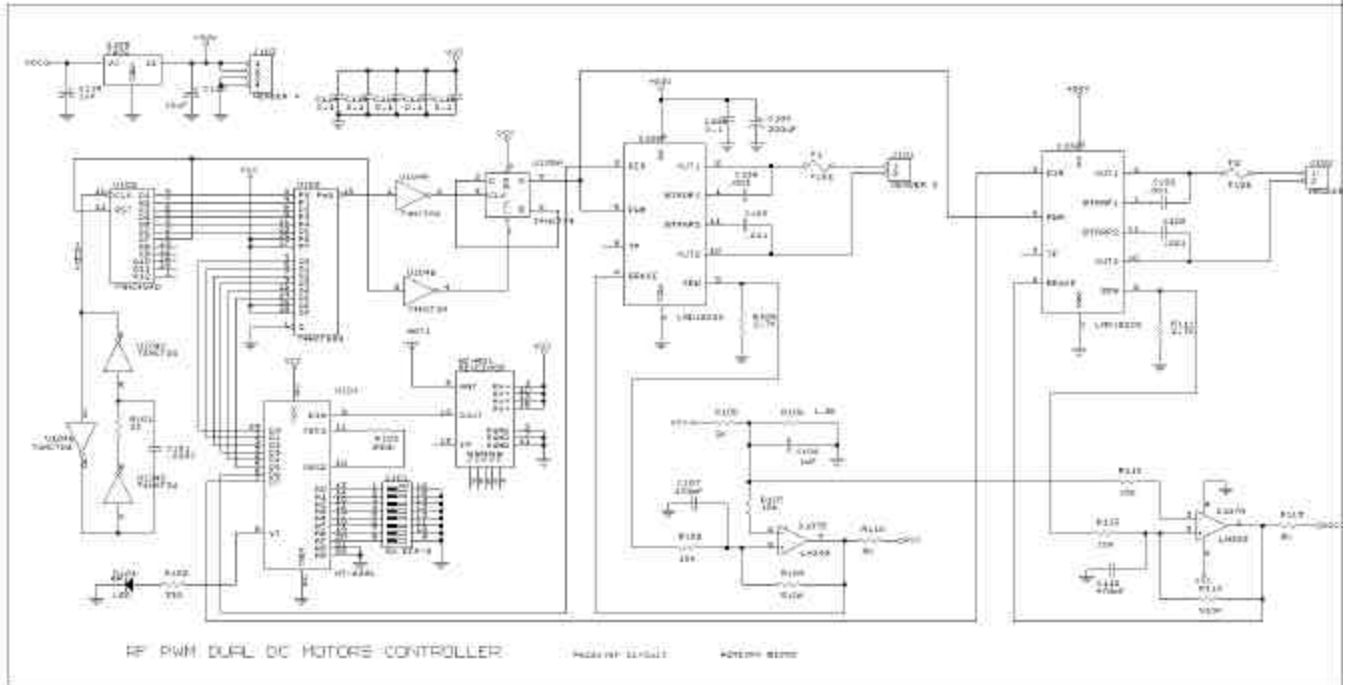

The receiver module WZ-R01 receives the data from the transmitter and feeds that data to the decoder U1 (HT-648L); the 8bit data will then be decoded. The first two significant bits D7 and D6 control the motor rotation direction. The lower 6 bits vary the duty cycle of the output pulse. U2 is a 12bit counter; it is configured so that it will reset itself every 64 counts. The oscillation circuit forms by U4c, U4d and U4e providing approximately 1MHz clock to the counter U2.

The 8-bit magnitude comparator U3 (74HCT688) compares the data from the counter U2 with the data of the decoder U1; when data from both are match, it will output a pulse to cause the D-flip flop U5 changing it's state.

By varying the data output of the decoder from 0-64, the duty cycle of the output pulse at U5 pin5 can also change from 0-100%. This output pulse will then be used to control the speed of the motor.

With 1MHz clock input the PWM frequency output is about 15.6KHz. The motor has less audible noise when run at a frequency higher than 10KHz. You may need to change the frequency depending on the motor you're going to use.

The motor driver section is very straightforward; the LMD18200 can handle 3A continuous motor current and 6A peak. In this circuit the sign/magnitude mode of operation is implemented. The current sensing circuit provides protection to both the driver and the motor; it set at 2A max. You can change the current limit by using a different current sensing resistor value (see LMD18200 data sheet for details) or the voltage reference at pin6 of the U7Op-Amp

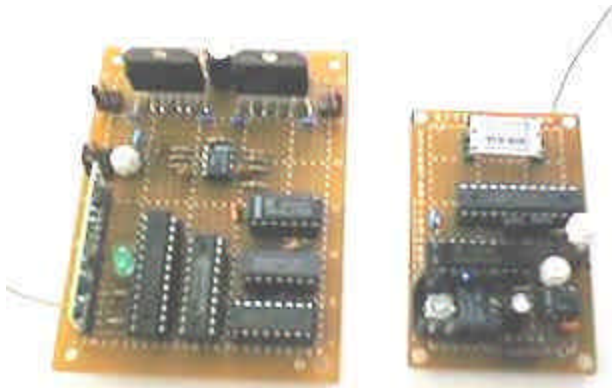

The above picture is the prototype, It works great! We had been able to control the motors at more than 100 feet away.

