

HEWLETT-PACKARD

HP 8560A/8561B/8563A Spectrum Analyzer Quick Reference Guide

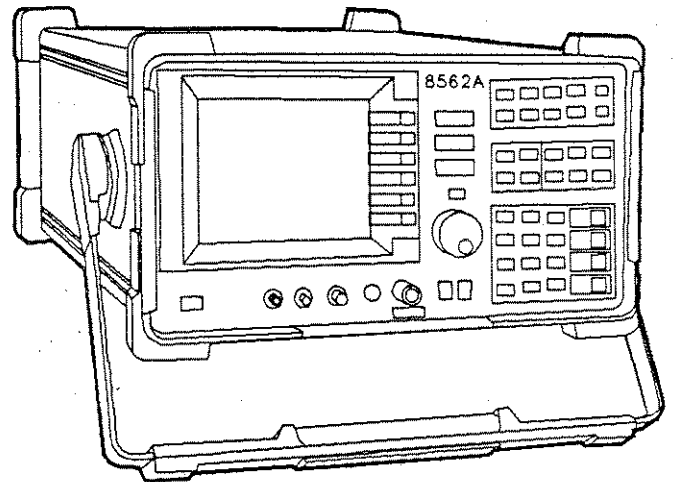

SPECTRUM ANALYZER 50Hz-2.9GHz

HEWLETT
PACKARD
8560A

INSTRUMENT STATE

PRESET CONFIG CAL COPY

MODULE SAVE RECALL MEAS/USER SOL SWP

MARKER CONTROL

MKR MKR → SWEEP BW TRIG

FREQ COUNT PEAK SEARCH AUTO COUPLE TRACE DISPLAY

DATA

7	8	9	GHZ 4-dBm dB
4	5	6	MHZ -dBm dBc
1	2	3	KHZ mV mV
0	.	ENTER	HZ µV µV

FREQUENCY

SPAN

AMPLITUDE

HOLD

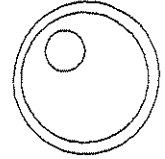

STEP

↑

↓

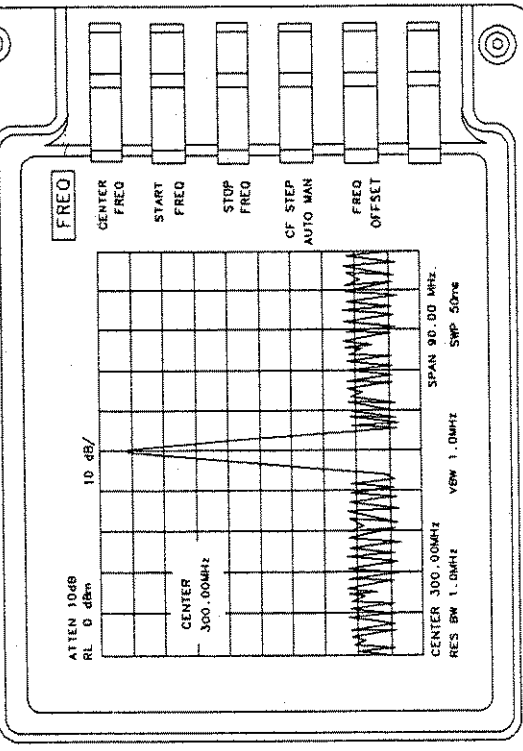

INPUT 50 Ω

50Hz - 2.9GHz

PROBE POWER

CAL OUTPUT

IF INPUT

1ST LO OUTPUT

VOLUME

LINE

0

300 MHz
-10 dBm

0Vdc MAX (1N) MAX

+30dBm

**HP 8560A/8561B/8563A Spectrum Analyzer
Quick Reference Guide**



Manual Part Number: 5958-7050
Microfiche Part Number: 5958-7051
Printed in the USA October 1989

Copyright © 1989 by Hewlett-Packard Company
1212 Valley House Drive, Rohnert Park, CA 94928-4999

Introduction

This guide provides a quick reference for experienced spectrum analyzer users.

The HP 8560A/8561B/8563A Quick Reference Guide is a convenient reference for both manual and automated measurements. Chapter 1 gives an overview of front-panel keys and connectors, rear-panel connectors, and display annotation. Chapter 2 leads you through a simple procedure that demonstrates some general-purpose measurement techniques. Chapters 3 and 4 document softkey functions and HP-IB commands. The appendixes list error messages and cross references to front-panel functions and programming commands. Menu trees and simplified block diagrams can be found at the end of the guide.

For additional instrument information, consult the *HP 8560A/8561B/8563A Operating and Programming Manual*, the *HP 8560A Installation and Verification Manual*, the *HP 8561B Installation and Verification Manual*, or the *HP 8563A Installation and Verification Manual*.

Contents

1	1. Instrument Overview	
1	The Front Panel	1-1
3	Display Annotation	1-4
	The Rear Panel	1-6
3	2. Making a Basic Measurement	
	Reference Level Calibration	2-6
	3. Function Descriptions	
	4. Programming Reference	
1	Introduction	4-1
1	How to Use This Guide	4-1
2	Notation Conventions	4-1
3	Syntax Conventions	4-1
5	Programming Codes (functional index)	4-1
5	Amplitude Control	4-1
5	Bandwidth Control	4-1
5	Coupling Control	4-1
6	Demodulation	4-1
6	Display Control	4-1
6	External Mixing*	4-1
7	Frequency Control	4-1
7	Information and Service Diagnostics	4-1
8	Instrument State Control	4-1
8	Marker Control	4-1
9	Operator Entry	4-1
9	Output Format Control	4-1
9	Plotter and Printer Output	4-1
9	Preselector Control	4-1

Service Request	4-9
Sweep and Trigger Control	4-10
Synchronization	4-10
Trace Functions	4-10
Processing	4-10
Math	4-11
Other	4-11
Tracking Generator Control	4-11
User Measurements	4-12
Programming Codes (alphabetical index)	4-13
Secondary Key Word Summary	4-47

- A. Error Messages
- B. Softkey Cross Reference
- C. Key versus Programming Command Cross Reference
- D. Programming Command versus Key
- E. Menu Trees
- F. Block Diagrams

Figures

1-1. HP 8560A Front Panel	1-1
1-2. Display Annotation	1-4
1-3. HP 8560A Rear Panel	1-6
2-1. 300 MHz Center Frequency	2-2
2-2. 20 MHz Frequency Span	2-3
2-3. Activated Normal Marker	2-4
2-4. -10 dBm Reference Level	2-5
2-5. Peaked Signal to Reference Level	2-7

Tables

1-1. Front-Panel Connector Data	1-3
3-1. Conversion-Loss Flatness Data	3-18
3-2. External Frequency Bands and Recommended Harmonics	3-18
A-1. Remote Operation Errors	A-2
A-2. Data and Other User-Generated Errors	A-4
B-1. Softkey Cross Reference	B-1
C-1. Softkey Cross Reference	C-1
D-1. Command versus Key	D-1

Instrument Overview

This chapter introduces the front- and rear-panel keys and connectors on the HP 8560A, HP 8561B, and HP 8563A Spectrum Analyzers. Complete descriptions of each front-panel function appear in Chapter 2 of the *HP 8560A/8561B/8563A Portable Spectrum Analyzer Operating and Programming Manual*.

The Front Panel

The following paragraphs briefly describe the groups of front-panel keys shown in Figure 1-1.

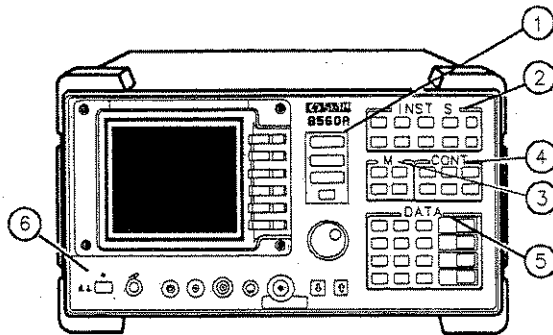

Figure 1-1. HP 8560A Front Panel

1. FREQUENCY, SPAN, and AMPLITUDE are the fundamental functions for most measurements. The HOLD key freezes the active function and holds it at a set value until a function key is pressed again. HOLD also blanks the

softkey menu and expands the graticule display horizontally to fill the full CRT.

2. INSTRUMENT STATE functions generally affect the state of the entire spectrum analyzer, not just the state of a single function.
3. MARKER functions read out frequencies and amplitudes along the spectrum analyzer trace; allow you to make relative measurements; automatically locate the signal of highest amplitude on a trace; and tune the analyzer to track a signal automatically.
4. CONTROL functions allow you to adjust the resolution and video bandwidths, the sweep time, and the display, and to vary other functions that control spectrum analyzer measurement capabilities.
5. DATA keys, STEP keys, and the knob allow you to change the numeric value of an active function. Use the data keys to enter an exact value or to move quickly from one end of the frequency range to the other. The step keys vary a value in predefined increments or, for some functions, in increments that you choose. The knob allows you to fine-tune most numeric values.
6. The front-panel connectors include an RF input, active-probe power, a 300 MHz calibrator signal, a 310.7 MHz IF input (not available on the HP 8560A Option 002), and a first LO output. A short specification summary of these connectors is outlined in Table 1-1. A volume knob is provided for making adjustments to the volume of the built-in speaker. The LINE button turns the spectrum analyzer on and off. The LED above the LINE button indicates whether or not ac power is applied to the spectrum analyzer.

Caution

The maximum input level to the 50 Ω input is +30 dBm with a minimum of 10 dB input attenuation. Both the HP 8560A and HP 8561B are ac/dc coupled. The HP 8563A is dc coupled only. When ac coupled, the maximum dc voltage to the RF input is 50 V. When dc coupled, no dc voltage should be presented to the RF input. The default power-up mode is ac coupled. It is best to leave the analyzer in ac-coupled mode for maximum protection. Exceeding the maximum safe input levels can damage the input attenuator and the input mixer.

Table 1-1. Front-Panel Connector Data

Connector	Frequency Range	Amplitude/ Voltage Limits
INPUT 50Ω	HP 8560A: 50 Hz—2.9 GHz (dc coupled) 100 kHz—2.9 GHz (ac coupled)	+30 dBm Max 0 V dc Max (dc coupled) 50 V dc Max (ac coupled)
	HP 8561B: 50 Hz—6.5 GHz (dc coupled) 100 kHz—6.5 GHz (ac coupled)	+30 dBm Max 0 V dc Max (dc coupled) 50 V dc Max (ac coupled)
	HP 8563A: 9 kHz—22 GHz (dc coupled)	+30 dBm Max 0 V dc Max (dc coupled)
PROBE POWER	—	+15 V, -12.6 V (150 mA max)
CAL OUTPUT	300 MHz	-10 dBm
IF INPUT* (for use with external mixers)	310.7 MHz	0 V dc Max
1ST LO OUTPUT	3.00 GHz—6.81 GHz	+16.5 dBm ±2.0 dB +14.5 dBm ±3.0 dB†
RF OUT 50Ω‡	300 kHz—2.9 GHz	-10 dBm to +1 dBm
* Not available with an HP 8560A Option 002. † LO output of an HP 8560A Option 002. ‡ Available only with an HP 8560A Option 002.		

Display Annotation

Figure 1-2 illustrates the display annotation; descriptions of the annotation follow.

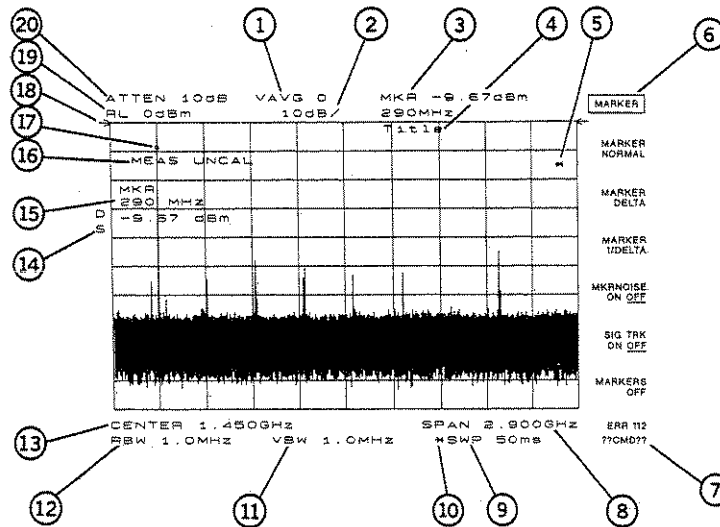

Figure 1-2. Display Annotation

1. Number of video averages.
2. Logarithmic or linear amplitude scale per division.
3. Marker amplitude and frequency.
4. Title area.
5. Data invalid indicator, displayed when analyzer settings are changed before completion of a full sweep.
6. Menu title and softkey menu.
7. Error message area.
8. Frequency span or stop frequency.

1-4 Instrument Overview

9. Sweep time.
10. Indicator of uncoupled function for sweep time, resolution bandwidth, video bandwidth, or input attenuation.
11. Video bandwidth.
12. Resolution bandwidth.
13. Center or start frequency.
14. Active special functions: the following characters appear in a vertical line alongside the graticule. This information is also available by pressing **ANNOT HELP** under the **DISPLAY** key.

A = IF adjust turned OFF
C = DC coupling selected (ac coupling is default)
D = Detector mode set to sample, negative peak, or positive peak
E = Special sweep-time equations in use (refer to tracking generator menus)
F = Frequency offset is less than or greater than 0 Hz
G = Internal tracking generator is ON
K = Signal track is ON
M = Trace math is ON
N = Normalization is ON
R = Reference level offset is less than or greater than 0 dB
S = Single-sweep mode
T = Trigger mode set to line, video, or external
X = 10 MHz reference is external
+ = External mixer bias is greater than 0 mA
- = External mixer bias is less than 0 mA

15. Active function area.
16. Message area.
17. Marker indicator.
18. Indicator of reference-level position when in normalized mode.
19. Reference level.
20. Input attenuator value or conversion loss when internal mixing or external mixing is used, respectively.

The Rear Panel

The functions available from the rear panel are shown in Figure 1-3; descriptions of these functions follow.

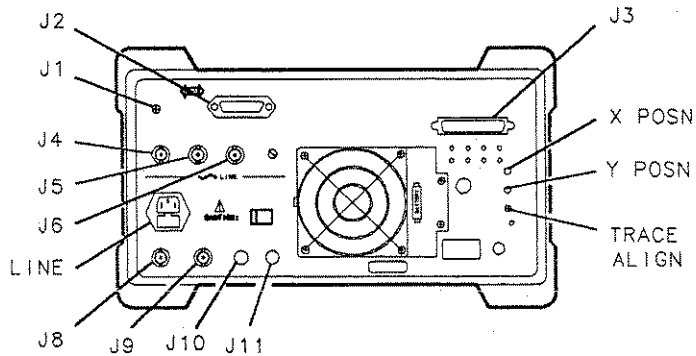

Figure 1-3. HP 8560A Rear Panel

Caution



To prevent damage to the instrument, be sure to set the voltage selector to the appropriate value for your local line-voltage output. For more information, refer to the *HP 8560A/8561B/8563A Installation and Verification Manual*.

The LINE input operates at nominally 115 V (47—440 Hz) or at nominally 230 V (47—66 Hz).

J1 provides a 4 Ω impedance earphone jack.

J2 is the Hewlett-Packard Interface Bus (HP-IB) connector.

J3 allows connection of option modules, such as the HP 85629B Test and Adjustment Module or the HP 85620A Mass Memory Module.

J4 provides a detected video signal that is proportional to the vertical deflection of the CRT trace. The output range is 0—1 V when terminated in 50 Ω , and can be used when the display is in 10 dB/div or LINEAR mode. For

1-6 Instrument Overview

resolution bandwidth settings less than 300 Hz, a 4.8 kHz IF signal with a dc offset is present at J4.

J5 provides an external trigger input. The input signal range is 0—5 V (TTL). When the trigger is in external mode, the instrument sweep triggers on the rising, positive edge of the signal (about +1.5 V).

J6 provides a blanking output from 0—5 V (TTL) that is low (0 V) during spectrum analyzer sweeps. The output is high (5 V) during retrace and when the instrument is between bands in multiband sweeps. Use this output for pen lift when plotting with nondigital plotters. This output is also useful for synchronizing instruments.

J8 provides two different selectable outputs: a 0—10 V ramp corresponding to the sweep ramp that tunes the local oscillator, or a sweeping dc output of 0.5 V/GHz. The sweeping dc output ranges from 0—2.9 GHz for an HP 8560A, 0—6.5 GHz for an HP 8561B, and 0—22 GHz for an HP 8563A. The output can be selected from the softkeys `0 -> 10V LO SWP` and `.5 V/GHz (FAV)`, respectively, which are in the `REAR PANEL` softkey menu under the `AUX CTRL` key. When using preselected external mixers, the 0.5 V/GHz output provides a signal of approximately 1.5 V/GHz of LO frequency to control the preselected mixer. External tracking generators, such as the HP 85640A, require the 0.5 V/GHz output for operation.

J9 provides a 10 MHz, 0 dBm minimum, time-base reference signal. This connector can be switched to an input, in order to connect an external reference. An external reference must be 10 MHz at a minimum of 0 dBm. To select the external reference mode, use the softkey `10 MHz EXT INT` in the `REAR PANEL` softkey menu under the `AUX CTRL` key.

J10 is the output for an HP 8560A Option 001, HP 8561B Option 001, or HP 8563A, 310.7 MHz IF output.

J11 is an external leveling input for use with an HP 8560A Option 002 (built-in tracking generator).

X POSN, Y POSN, and TRACE ALIGN allow you to align the spectrum analyzer CRT using a special CRT pattern. Refer to the softkey `CRT ADJ PATTERN` under the `CAL` menu, or consult the *HP 8560A/8561B/8563A Installation and Verification Manual* for your instrument.

Making a Basic Measurement

A basic measurement involves tuning the spectrum analyzer to place a signal on the screen, then measuring the frequency and amplitude of the signal with marker.

We can measure an input signal in four simple steps.

1. Set the center **frequency**.
2. Set the frequency **span**.
3. Activate the **marker**.
4. Set the **amplitude**.

As an example, we will measure the 300 MHz calibration signal. First, turn on the spectrum analyzer (for maximum accuracy, if the analyzer has just been powered up, allow for a 5-minute warm-up). Press **PRESET**, connect the analyzer's CAL OUTPUT to the INPUT 50Ω on the front panel, and complete the four steps as described below.

1. Set the center frequency.

Press **FREQUENCY**. This activates the center frequency function, indicated by **CENTER** appearing in the active function block on the left side of the display. See Figure 2-1. To set the center frequency to 300 MHz, use the keys in the **DATA** section of the front panel and enter 300 MHz. These data keys allow you to select the exact numeric value of the active function, which, in this case, is the center frequency. The step keys and knob also allow you to select function values.

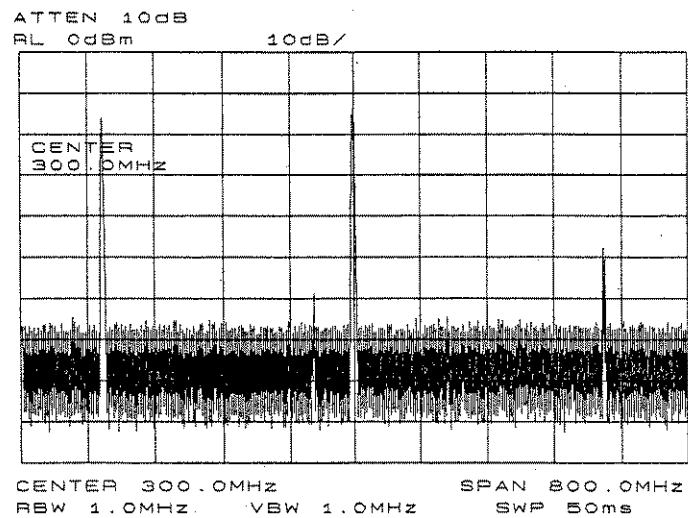

Figure 2-1. 300 MHz Center Frequency

2-2 Making a Basic Measurement

2. Set the frequency span.

Press **SPAN**. Note that SPAN is now displayed in the active function block, identifying it as the current active function. To reduce the frequency span—for example, to 20 MHz—either key in 20 MHz or use the STEP **▼** key to “step down” to this value. (Like data keys, step keys can also be used to change the numeric value of the active function.) The resulting display is shown in Figure 2-2. Note that the resolution and video bandwidths are coupled to the frequency span; they are automatically adjusted to appropriate values for a given span. (Sweep time is also a coupled function.)

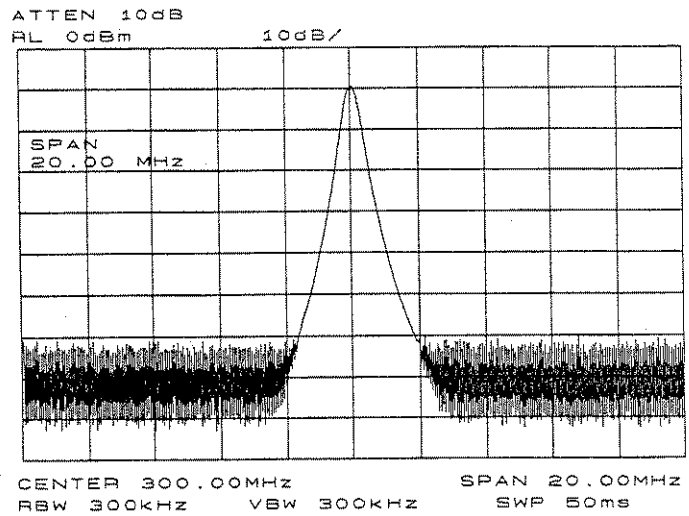

Figure 2-2. 20 MHz Frequency Span

3. Activate the marker.

Press **MKR**, which is located in the MARKER section of the front panel. This activates the normal marker and places it at the center of the trace (in this case, at or near the peak of the signal). Use the knob to place the marker at the peak of the signal. The marker reads both the frequency and the amplitude, and displays these values in the active function block. In this case, the marker reads "300.00 MHz" and "-10.00 dBm", as shown in Figure 2-3.

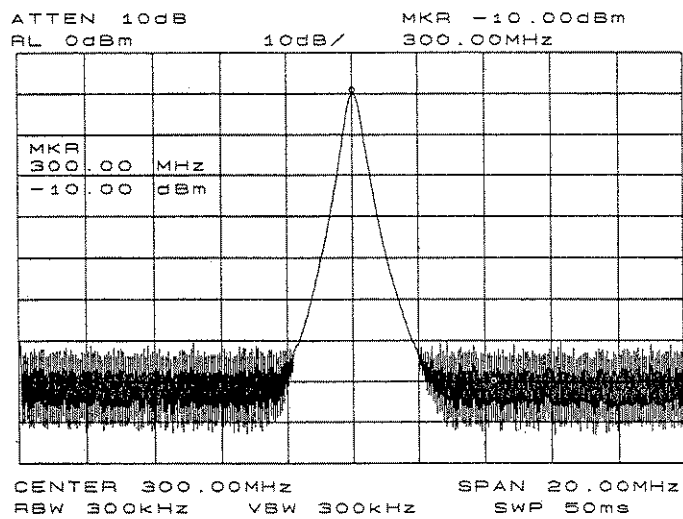

Figure 2-3. Activated Normal Marker

2-4 Making a Basic Measurement

4. Set the amplitude.

Generally, placing the signal peak at the reference level provides the best measurement accuracy. When a marker is active, a fast method to fine-tune the signal peak to the reference level is to use **MARKER → REF LVL**, which is located under the **MKR ->** key. This function sets the reference level equal to the marker amplitude value. See Figure 2-4. When no marker is active, to adjust the signal peak to the reference level press **AMPLITUDE**, then key in -10 dBm, or use either the step keys or the knob. Using the knob is the easiest way to fine-tune the signal peak to the reference level, which is located at the top of the graticule.

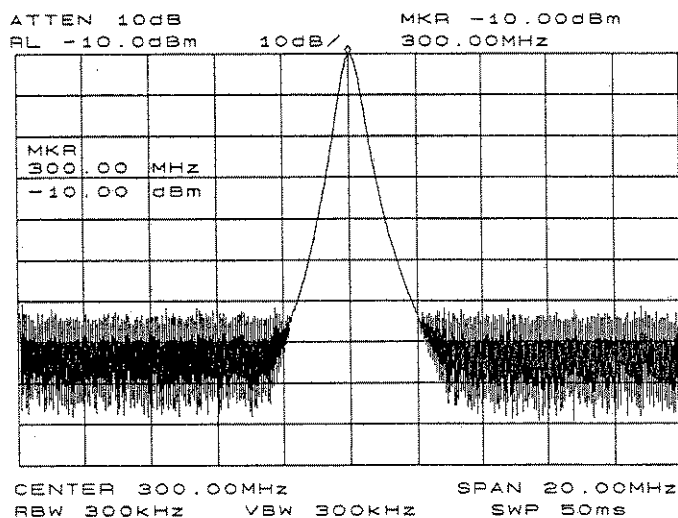

Figure 2-4. -10 dBm Reference Level

Reference Level Calibration

The reference-level calibration function, **REF LVL ADJ**, permits adjusting the spectrum analyzer's internal gain so that when the calibrator is connected to the input, the reference level at top-screen equals the calibrator amplitude. Use the instrument state from the previous example and follow the procedure below to calibrate the reference level.

Turn the marker off by pressing **(MKR) MARKERS OFF**. Press **(CAL)**. This accesses a menu of calibration routines. The fifth function on this list is **REF LVL ADJ**. Press **REF LVL ADJ** to activate the function. To calibrate the spectrum analyzer, use the knob on the front panel to adjust the peak of the signal to the reference level, as shown in Figure 2-5. Note the number that appears in the active function block. In this example, the number 1 appears when the signal is adjusted. This number, which ranges from -33 to +33, is a relative value indicating how much amplitude correction was required to calibrate the spectrum analyzer. The number is usually around 0. If the amplitude is at either end of the range, or if it cannot be adjusted to a value within this range, consult the Installation and Verification Manual. To store the value, press **STORE REF LVL**. When entering or storing a value using the data keys, the entry must be terminated by pressing **(ENTER)**, which is located in the lower right-hand corner of the analyzer.

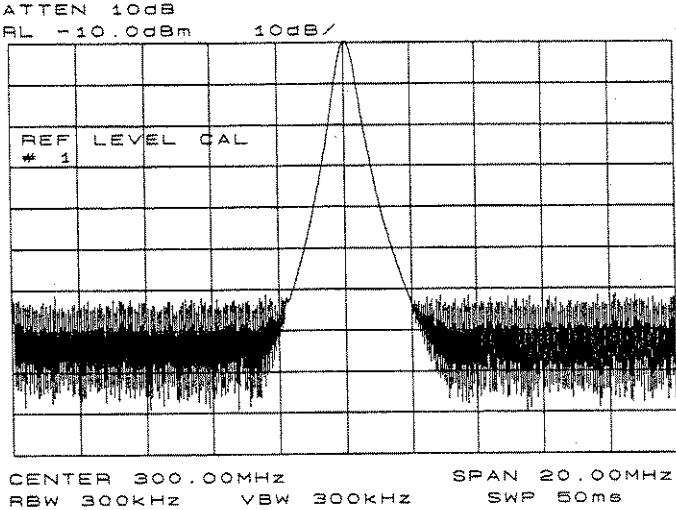

Figure 2-5. Peaked Signal to Reference Level

Recalibrating the reference level is usually necessary only when the ambient temperature changes more than 10°C. Because the spectrum analyzer continually monitors and reduces any IF errors, executing the reference-level calibration is seldom necessary.

Function Descriptions

This chapter lists the HP 8560A, HP 8561B, and HP 8563A front-panel functions in alphabetical order. Next to each key is a brief description of its operation. Tables are located at the end of the chapter. For detailed descriptions, refer to the *HP 8560A/8561B/8563A Portable Spectrum Analyzer Operating and Programming Manual*.

0—10V LD SWP

Selects as output for J8 (on the rear panel) the 0 to 10 volt ramp corresponding to the sweep ramp that tunes the local oscillator.

0.5 V/GHz (FAV)

Specifies a 0.5 volts per GHz sweep output (the “frequency-analog voltage”) at the rear-panel sweep output J8; primarily used with external tracking generators.

10 MHz EXT INT

Selects an external (EXT) or internal (INT) frequency reference. When external mode is selected an X appears on the left side of the display.

A+B→A

Adds the contents of trace A with those of trace B and places the result in trace A.

A-B→A ON OFF

When it is ON, this function continuously subtracts the contents of trace B from those of trace A, and places the result in trace A. An M appears on the left side of the display when this function is on.

A-B+DL→A ON OFF

When it is ON, this function subtracts the contents of trace B from those of trace A, adds the display line to the result, then places the result in trace A. An M appears on the left side of the display when this function is on.

ADJ CURR IF STATE	Adjusts various parameters in the IF bandwidth currently in use, producing optimum amplitude accuracy.
A EXCH B	Exchanges the contents of trace A with those of trace B, then places traces A and B in view mode.
AGC ON OFF	Switches automatic gain control on or off and keeps the volume relatively constant during AM demodulation.
ALC INT EXT	Selects internal or external leveling, which improves the amplitude accuracy of tracking generator measurements. <i>Available with an HP 8560A Option 002 only.</i>
ALL	Couples all "AUTO" functions: resolution bandwidth, video bandwidth, sweep time, input attenuation, center frequency step-size, and amplitude units.
AM DEMOD ON OFF	Turns AM demodulation on and off.
AM/FM DEMOD	Accesses functions for AM or FM demodulation.
AMPLITUDE	Activates the reference level function and accesses a menu of amplitude related functions.
AMPTD CORRECT	Accesses functions that set conversion loss and flatness data for external mixer measurements. <i>Not available with an HP 8560A Option 002.</i>
AMPTD UNITS	Accesses a menu of amplitude units.
ANALYZER ADDRESS	Displays the current HP-IB address of the spectrum analyzer, which can be changed, entered, and then stored using STORE HP-IB .
ANNOT HELP	Displays descriptions of the annunciators that appear on the left-hand side of the screen.
ANNOT ON OFF	Switches the display annotation on and off.

3-2 Function Descriptions

ATTEN AUTO MAN

Adjusts the spectrum analyzer input attenuator, which is either coupled to the reference level (AUTO) or adjusted manually (MAN). *Internal mixing only.*

AUTO COUPLE

Accesses a menu of couple-mode functions.

AUX CTRL

Accesses a menu of tracking generator, internal mixer, external mixer, demodulation, and rear-panel functions.

AVERAGE CNV LOSS

Displays the mean conversion loss for the current harmonic and allows you to enter new conversion loss data. Any change to the average conversion loss also affects flatness data. *Not available with an HP 8560A Option 002.*

B-DL→B

Subtracts the display-line value from the contents of trace B, then places the result in trace B.

BACK SPACE

Deletes the last character placed in the current title.

BIAS

Displays a menu of functions for selecting unpreselected external-mixer bias. *Unpreselected external mixing only and not available with an HP 8560A Option 002.*

BIAS OFF

Turns external-mixer bias off. *Not available with an HP 8560A Option 002.*

BLANK A

Blanks the contents of trace A from the display.

BLANK B

Blanks the contents of trace B from the display.

B & W

Selects a monochromatic printer configuration for use with **COPY**.

CAL

Accesses a menu of calibration functions.

CAL OPN/SHRT

Measures and computes the average of an open- and a shorted-input calibration, then stores the data in trace B and in instrument state register 8. Use when making reflection measurements with a tracking generator.

CAL THRU	Stores thru calibration in trace B and in instrument state register 9. Use when making transmission measurements with a tracking generator.
CENTER FREQ	Activates the center frequency function and sets the spectrum analyzer to center frequency/span mode.
CF STEP AUTO MAN	Adjusts the center frequency step-size so that when a step key is pressed, the center frequency shifts by the selected step size. This function may be coupled to the frequency span function (AUTO), or set manually (MAN).
CHAR SET 1 2	Accesses character sets used for creating titles.
CLEAR WRITE A	Clears trace A and sets it to accept and display new input-signal data continuously.
CLEAR WRITE B	Clears trace B and sets it to accept and display new input-signal data continuously.
CNV LOSS VS FREQ	Displays the conversion loss for a specific frequency in the current band. For use with external mixers; see Table 3-1. <i>Not available with an HP 8560A Option 002.</i>
COLOR	Selects the HP PaintJet or similar color printer configuration for use with COPY .
CONFIG	Accesses a menu of functions used to configure a plotter and a printer as hard-copy devices, set the spectrum analyzer HP-IB address, and view the instrument datecode and options.
CDNT	Activates continuous-sweep mode.
COPY	Copies the display contents onto a plotter or a printer.
COPY DEV PRNT PLT	Selects a printer or a plotter as the hard-copy device used when COPY is activated.

3-4 Function Descriptions

COUNTER ON OFF

Switches the precision frequency counter ON and OFF (activating a marker if none is present), and displays counter results when the counter is on.

COUNTER RES

Adjusts the resolution of the frequency counter readout.

COUPLING AC DC

Selects ac or dc coupling to the input; ac coupling protects the input of the analyzer from damaging dc signals. When dc coupling is selected, a C appears on the left edge of the display. *Not available with an HP 8563A.*

CRT ADJ PATTERN

Displays an alignment pattern which is used in conjunction with X POSN, Y POSN, and TRACE ALIGN adjustments (located on the rear panel).

DATECODE & OPTIONS

Displays the analyzer's firmware datecode, its instrument serial number, its model number, and any options present.

dB/ μ V

Selects absolute decibels relative to 1 microvolt as the amplitude units.

dBm

Selects absolute decibels relative to 1 milliwatt as the amplitude units.

dBmV

Selects absolute decibels relative to 1 millivolt as the amplitude units.

DEMOD TIME

Selects the duration of demodulation between successive sweeps.

DETECTOR MODES

Accesses a menu of detector modes.

DETECTOR NEG PEAK

Selects negative-peak detection of the video signal and places a D on the left side of the display.

DETECTOR NORMAL

The normal-detector mode alternately displays positive and negative-peaks when the presence of noise is detected, and displays positive peaks otherwise.

DETECTOR POS PEAK

Selects positive-peak detection of the video signal and places a D on the left side of the display.

DETECTOR SAMPLE	Samples the video signal and places a D on the left side of the display.
DISPLAY	Accesses a menu of display-related functions.
DSPL LIN ON OFF	Switches the display line on and off.
ELAPSED TIME	Displays the cumulative operating time of the spectrum analyzer.
ERASE TITLE	Erases the current title from the display.
EXTERNAL	Sets the trigger to external mode; connect external trigger sources to J5 (EXT TRIG INPUT) on the rear panel. When this mode is selected a T appears on the left side of the display.
EXTERNAL MIXER	Accesses a menu of external-mixer functions. <i>Not available with an HP 8560A Option 002.</i>
EXT MXR PRE UNPR	Selects either preselected or unpreselected external mixing mode. <i>Not available with an HP 8560A Option 002.</i>
FACTORY PRSEL PK	Restores the factory preselector-peaking data as the current preselector data. <i>HP 8561B and HP 8563A internal mixing only.</i>
FFT MEAS	Performs a discrete Fourier transform on the input signal, converting zero-span information into the frequency domain.
FM DEMOD ON OFF	Switches FM demodulation ON and OFF.
FOCUS	Permits focusing of the display using the data keys, the step keys, or the knob.
FREE RUN	Sets the trigger to free-run mode; sweep triggers occur as rapidly as the spectrum analyzer will allow.
FREQ COUNT	Turns on the frequency counter (and a marker if none is present) and accesses a menu of counter and marker functions.

3-6 Function Descriptions

FREQ DIAGNOSE

Accesses a menu of diagnostic functions which allow various internal parameters to be retrieved.

FREQ DSP OFF

Turns off all frequency related annotation.

FREQ OFFSET

Adds an offset value to displayed frequency values, including marker frequency values. The range of the sweep (that is, the span) is not affected. When this function is active an F appears on the left edge of the display.

FREQUENCY

Activates the center frequency (or the start frequency) and accesses a menu of frequency functions.

FULL BAND

Selects commonly-used frequency bands above 18 GHz and activates the harmonic-lock function. See Table 3-2. *Not available with an HP 8560A Option 002.*

FULL IF ADJ

Executes a complete adjustment of the IF system for optimum measurement accuracy.

FULL SPAN

Sets the spectrum analyzer span to its maximum frequency range.

GRAT ON OFF

Turns the display graticule ON and OFF.

HOLD

Holds the active function to its present value, blanks the softkeys from the display, and expands the remaining display.

IF ADJ ON OFF

Switches the automatic IF adjustment ON and OFF. When it is ON, various IF parameters are adjusted during retrace to ensure amplitude accuracy within specifications. If this function is turned off an A appears on the left side of the display.

INTENSTY

Permits changing the display intensity using the data keys, step keys, or the knob.

INTERNAL MIXER	Accesses a menu of signal-identification functions or returns the spectrum analyzer from external-mixer mode to its internal frequency coverage. <i>Not available with an HP 8560A Option 002.</i>
LAST SPAN	Sets the spectrum analyzer to the previously-selected span.
LAST STATE	Recalls the state that existed before preset was pressed or power was turned off.
LINE	Sets the trigger to line mode; sweep triggers occur at intervals synchronized to the line frequency. When this mode is selected a T appears on the left side of the display.
LINEAR	Selects the linear amplitude scale.
LOCK HARMONIC	Displays the number of the harmonic currently used to sweep the selected frequency band. Only frequencies and spans that fall within the frequency band of the current harmonic may be entered. See Table 3-2. <i>Not available with an HP 8560A Option 002.</i>
LOCK ON/OFF	Turns the harmonic lock on and off. When it is on, it performs the same function as LOCK HARMONIC . <i>Not available with an HP 8560A Option 002.</i>
LO FREQ	Displays the first local-oscillator frequency corresponding to the current start frequency.
LOG dB/DIV	Selects a 1, 2, 5, or 10 dB logarithmic amplitude scale.
MAIN ROLLER	Displays the main-roller-oscillator frequency corresponding to the current start frequency.
MAN TRK ADJ	Permits manual adjustment of the tracking generator oscillator using the data keys, the step keys or the knob. <i>HP 8560A Option 002 only.</i>

3-8 Function Descriptions

MARKER→CF

Sets the center frequency equal to the marker frequency.

MARKER→CF STEP

Sets the center frequency step-size equal to the marker frequency; the step keys change the center frequency in increments equal to the delta value.

MARKER→REF LVL

Sets the reference level equal to the amplitude of the marker.

MARKER DELTA

Reads the difference in amplitude and in frequency (or time when the span equals 0 Hz) and displays these values.

MARKER 1/DELTA

Sets the marker readout to a frequency equal to the reciprocal of the delta value. For use with zero span mode.

MARKER NORMAL

Activates a single marker and places it at the center of the trace.

MARKERS OFF

Turns all markers off, blanks the softkey menu, and expands the display.

MAX HOLD A

Displays and holds the maximum responses of the input signal in trace A.

MAX HOLD B

Displays and holds the maximum responses of the input signal in trace B.

MAX MXR LEVEL

Selects the maximum mixer level seen at the input mixer for signals at or below the reference level.

Internal mixing only.

MEAS/USER

Accesses softkeys that perform user-defined functions power bandwidth, and FFT measurements.

MKR

Activates a marker and accesses a menu of marker functions.

MKR→

Activates a marker and accesses a menu of marker functions.

MKR Δ→CF

Sets the center frequency equal to the delta frequency value.

MKR Δ →CF STEP

Sets the center frequency step-size equal to the delta frequency value.

MKR Δ →SPAN

Sets the frequency span equal to the delta frequency value.

MKR $1/\Delta$ →CF

Sets the center frequency equal to the reciprocal of the delta value. For use in zero span mode.

MKR $1/\Delta$ →CF STEP

Sets the center frequency step-size equal to the reciprocal of the delta value. For use in zero span mode.

MKRNOISE ON OFF

Turns the marker noise function on or off. When it is on, it normalizes the equivalent amplitude of the measured noise to a 1 Hz bandwidth. Not for use with tracking generators.

MODULE

Accesses the functions of an optional, rear panel module when it is present.

NEGATIVE BIAS

Selects negative bias for an external mixer. When this function is selected a - appears on the left side of the display. *Not available with an HP 8560A Option 002.*

NEXT PEAK

Moves the active marker to the next-highest trace peak relative the current marker position.

NEXT PK LEFT

Finds the next peak to the left of the current marker position.

NEXT PK RIGHT

Finds the next peak to the right of the current marker position.

NORMLIZE ON OFF

Switches the normalization routine for stimulus-response measurements on and off. An N appears on the left side of the display when this function is active.

NORM REF LVL

Activates the normalized reference level, permitting an offset to be introduced to the displayed trace. For use with **NORMLIZE ON OFF**.

3-10 Function Descriptions

NORM REF POSN

Adjusts the normalized-reference position; for use with **NORMLIZE ON OFF**.

OFFSET ROLLER

Displays the offset-roller-oscillator frequency corresponding to the start frequency.

PEAK EXCURSN

Defines what constitutes a peak on a trace. The selected value specifies the amount that a trace must increase monotonically then decrease monotonically in order to be a peak.

PEAK SEARCH

Places a marker at the highest point on a trace and accesses a menu of marker functions.

PEAK SEARCH

Places a marker on the highest point on a trace and displays the marker frequency and amplitude.

PEAK THRESHLD

Sets the minimum amplitude level from which a peak on a trace can be detected.

PLOT ANNOT

Plots only the display annotation. To halt plotting before it is complete, press **STOP ANNOT**.

PLOT GRATICUL

Plots only the graticule. To halt plotting before it is complete, press **STOP GRAT**.

PLOT ORG DSP GRAT

Selects either the display (DSP) or the graticule area (GRAT) for plotting. In either case, the plot fills the entire area defined by the P1 and P2 plot parameters.

PLOTTER ADDRESS

Displays the HP-IB address of the plotter. After changing and entering the address, press **STORE HP-IB ADR**.

PLOTTER CONFIG

Accesses a menu for configuring a plotter as a hard-copy device.

PLOT TRACE A

Plots only the contents of trace A and any markers associated with the trace. To halt plotting before it is complete, press **STOP TRACE A**.

PLOT TRACE B	Plots only the contents of trace B and any markers associated with the trace. To halt plotting before it is complete, press STOP TRACE B .
POSITIVE BIAS	Selects positive mixer bias for an external mixer. When this function is selected a + appears on the left side of the display. <i>Not available with an HP 8560A Option 002.</i>
POWER BANDWIDTH	Integrates the power displayed and returns the bandwidth containing 99% of the total displayed power.
POWER ON	Sets the instrument state to the state stored in the power-on register.
PRESEL AUTO PK	Automatically peaks the preselector for the desired signal on a trace.
PRESEL MAN ADJ	Permits manual adjustment of the preselector. Peak the preselector using the data keys, the step keys, or the knob.
PRESEL PEAK	Displays a menu of functions for preselected external mixers. <i>Preselected external mixing only.</i>
PRESET	Presets the spectrum analyzer.
PRINTER ADDRESS	Displays the HP-IB address of the printer. After changing the address, press STORE HPIB ADR .
PRINTER CONFIG	Accesses a menu for configuring a printer as a hard-copy device.
PWR ON STATE	Saves the current state in the power-on register; the spectrum analyzer is set to this state whenever LINE is turned on or when POWER ON is pressed.
PWR SWP ON OFF	Switches the power-sweep function on and off. The tracking generator output power sweeps over the chosen amplitude range. <i>HP 8560A Option 002 only.</i>

3-12 Function Descriptions

RANGE LVL

Activates the dynamic-range-level function and ensures the displayed range is compression-free. For use with **NORMLIZE ON OFF**.

RBW/SPAN RATIO

Displays the current coupling ratio between the resolution bandwidth and the frequency span.

REALIGN LO & IF

Activates the LO and IF alignment routines for a complete LO and IF alignment.

RECALL

Accesses a menu of functions that recall instrument data.

RECALL ERRORS

Displays the last error that has occurred. Use the step keys to cycle through accumulated errors.

RECALL OPN/SHRT

Recalls the stored, averaged open/short calibration data into trace B, and sets the instrument to the calibration state.

RECALL PRSEL PK

Recalls the preselector data initially stored in the user table using **SAVE PRSEL PK**. *For use with preselected external mixing and HP 8561B and HP 8563A internal mixing.*

RECALL STATE

Displays a menu of ten registers from which instrument states can be recalled and displayed.

RECALL THRU

Recalls stored thru-calibration data into trace B and sets the instrument to the calibration state.

RECALL TO TR A

Displays a menu of eight registers from which data can be recalled and placed in trace A.

RECALL TO TR B

Displays a menu of eight registers from which data can be recalled and placed in trace B.

REAR PANEL

Accesses a menu for selecting the signal available at J8 (LO SWP|0.5V/GHz OUTPUT) and at J9 (10 MHz REF IN/OUT).

REF LVL

Activates the reference-level function.

REF LVL ADJ	Permits adjusting the spectrum analyzer's internal gain so that when the calibrator signal is connected to the input, the reference level at top-screen equals the calibrator amplitude.
REF LVL OFFSET	Introduces an offset to all amplitude readouts, but does not change the position of the on-screen trace. When this function is active an R appears on the left side of the display.
RES BW AUTO MAN	Adjusts the resolution bandwidth of the spectrum analyzer. The resolution bandwidth may be coupled to other functions (AUTO) or adjusted manually (MAN).
SAMPLER FREQ	Displays the sampling-oscillator frequency corresponding to the current start frequency.
SAMPLER HARMONIC	Displays the sampler harmonic number corresponding to the current start frequency.
SAVE	Accesses a menu for storing instrument data.
SAVELOCK ON OFF	When this function is on, the data in the state and trace registers cannot be erased or overwritten; no new data may be entered into the registers until this function is turned off.
SAVE PRSEL PK	Saves the current preselector-peak data in a user data table. <i>For use with preselected external mixing and HP 8561B and HP 8563A internal mixing.</i>
SAVE STATE	Displays a menu of ten registers for storing the current instrument state.
SAVE TRACE A	Displays a menu of nine registers for storing trace contents.
SAVE TRACE B	Displays a menu of nine registers for storing trace contents.
SCREEN TITLE	Accesses a menu of functions for creating on-screen titles.

3-14 Function Descriptions

SELECT CHAR

Causes the currently selected character in the active block to appear in the next available position of the title.

SGL SWP

Initiates one sweep and activates single-sweep mode.

SIG ID AT MKR

Locates the frequency and harmonic number of the mixer response where a marker has been positioned. *Not available with an HP 8560A Option 002.*

SIG ID→CF

Sets the center frequency to the frequency obtained from executing **SIG ID AT MKR**. *Not available with an HP 8560A Option 002.*

SID ID ON OFF

Switches manual signal identification on and off. Signals that are correct for the selected band are shifted less than 50 kHz. Limit frequency spans to less than 20 MHz for best performance. *Not available with an HP 8560A Option 002.*

SIGNAL IDENT

Accesses a menu of signal-identification functions. *Unpreselected external mixing only and not available with an HP 8560A Option 002.*

SIG TRK ON OFF

Switches the signal-tracking function ON and OFF. When it is ON, it keeps the active marker on the peak of the signal where it was initially placed and sets the center frequency to the marker value. A K appears on the left side of the display to indicate this function is active.

SINGLE

Activates the single-sweep mode. Pressing **SINGLE** initiates one sweep. When this function is active, an S appears on the left side of the display.

SOURCE CAL MENU

Accesses a menu of functions used to calibrate frequency-response errors in test setups when using tracking generator.

SPACE

Places a blank space in the next available character position in the title.

SPAN	Activates the frequency span, sets the spectrum analyzer to center-frequency/span mode, and accesses a menu of span-related functions.
SPAN	Activates the span-width function and sets the spectrum analyzer to center-frequency/span mode.
SPAN ZOOM	Tracks a marked signal and activates the span function so that the span may be reduced quickly without losing the signal from the display. If no marker is present, the peak-search function is executed before the span is reduced. See also SIG TRK ON OFF .
SQUELCH ON OFF	Adjusts the squelch level for demodulation.
SRC PWR OFFSET	Offsets the displayed power of the tracking generator. <i>HP 8560A Option 002 only.</i>
SRC PWR ON OFF	Switches the tracking generator output power on and off. A G appears on the left side of the display when this function is active. <i>HP 8560A Option 002 only.</i>
SRC PWR STP SIZE	Sets the step-size of the source power level, the source power offset, and the power-sweep range functions. <i>HP 8560A Option 002 only.</i>
START FREQ	Activates the start frequency and sets the spectrum analyzer to start/stop mode.
STOP FREQ	Activates the stop frequency and sets the spectrum analyzer to start/stop mode.
SWEEP	Activates the sweep-time function and accesses a menu of sweep related functions.
SWP CPL SR SA	Selects an auto-coupled, sweep time equation for stimulus-response (SR) measurements with a tracking generator or for spectrum-analyzer (SA) measurements. When SR mode is selected an E appears on the left side of the display.

3-16 Function Descriptions

SWP TIME AUTO MAN

Adjusts the sweep time of the spectrum analyzer. The sweep time may be coupled to bandwidth and span settings (AUTO) or adjusted manually (MAN).

THRESHLD ON OFF

Sets a threshold that determines the lower limit of an active trace. Adjust the threshold using the data keys, the step keys, or the knob.

TITLE DONE

Fixes the current title.

TRACE

Accesses a menu of trace functions.

TRACE A B

Accesses trace-related functions for traces A and B.

TRACKING GENERATOR

Accesses a menu of tracking-generator functions.

TRACKING PEAK

Adjusts the coarse and fine tracking adjustments to peak the tracking generator response on the spectrum analyzer display automatically. *HP 8560A Option 002 only.*

TRANSFER ROLLER

Displays the transfer-roller oscillator frequency corresponding to the start frequency.

TRIG

Accesses a menu of trigger functions.

UNITS AUTO MAN

Accesses a menu of amplitude units. AUTO indicates default units for the amplitude scale are in use; MAN indicates other units have been selected.

VBW/RBW RATIO

Displays the coupling ratio between the video bandwidth and the resolution bandwidth.

VID AVG ON OFF

Turns video averaging on and off. It smooths the trace by averaging successive traces with each other.

VIDEO

Sets the trigger to video modem. Sweep triggers occur whenever the input signal passes through, with a positive slope, the video trigger level. When this mode is selected a T appears on the left side of the display.

Table 3-1. Conversion-Loss Flatness Data

Band	Frequency Range	Number of Flatness Points	Point Spacing	Conversion Loss
6 (K)	18.6—26.5 GHz	6	2 GHz	30 dB
7 (A)	26.5—40.0 GHz	8	2 GHz	30 dB
8 (Q)	33.0—50.0 GHz	7	3 GHz	30 dB
9 (U)	40.0—60.0 GHz	6	4 GHz	30 dB
10 (V)	50.0—75.0 GHz	6	5 GHz	30 dB
11 (E)	60.0—90.0 GHz	7	5 GHz	30 dB
12 (W)	75.5—110.0 GHz	8	5 GHz	30 dB
13 (F)	90.0—140.0 GHz	6	10 GHz	30 dB
14 (D)	110.0—170.0 GHz	7	10 GHz	30 dB
15 (G)	140.0—220.0 GHz	9	10 GHz	30 dB
16 (Y)	170.0—260.0 GHz	7	15 GHz	30 dB
17 (J)	220.0—325.0 GHz	8	15 GHz	30 dB

Table 3-2.**External Frequency Bands and Recommended Harmonics**

Band	Frequency Range	Mixing Harmonic	Conversion Loss
6 (K)	18.6—26.5 GHz	6— (External)	30 dB
7 (A)	26.5—40.0 GHz	8— (External)	30 dB
8 (Q)	33.0—50.0 GHz	10— (External)	30 dB
9 (U)	40.0—60.0 GHz	10— (External)	30 dB
10 (V)	50.0—75.0 GHz	14— (External)	30 dB
11 (E)	60.0—90.0 GHz	16— (External)	30 dB
12 (W)	75.5—110.0 GHz	18— (External)	30 dB
13 (F)	90.0—140.0 GHz	24— (External)	30 dB
14 (D)	110.0—170.0 GHz	30— (External)	30 dB
15 (G)	140.0—220.0 GHz	36— (External)	30 dB
16 (Y)	170.0—260.0 GHz	44— (External)	30 dB
17 (J)	220.0—325.0 GHz	54— (External)	30 dB

Programming Reference

Introduction

The following pages describe HP 8560A, HP 8561B, and HP 8563A programming codes. Detailed information of each command can be found in the *HP 8560A/8561B/8563A Portable Spectrum Analyzer Operating and Programming Manual*.

How to Use This Guide

This reference is written for the experienced spectrum analyzer programmer. To find a programming code which performs a particular function, first refer to "Programming Codes (functional index)" in this reference. The index shows programming codes grouped according to similar function, and includes the code and a brief definition. Once the desired code is found, refer to the "Programming Codes (alphabetical index)" in this reference for a more detailed key word description and syntax information. An example of how to use each command is also given. The examples are written in HP BASIC for the HP 9000 Series 200 and 300 computers.

For more information on syntax, refer to "Notation Conventions" and "Syntax Conventions" in this reference. Secondary key words are parameters appearing in capital letters within the argument of key words. Their definitions can be found under "Secondary Key Word Summary" in this reference.

Notation Conventions

The following symbols and type styles found in this guide denote the following:

- BOLD TYPE** All characters appearing in bold type are key words and must appear exactly as shown.
- CAPITAL LETTERS** All characters that are capital letters are secondary key words and appear within the key word syntax. They must appear exactly as shown; their meanings can be found under "Secondary Key Word Summary."
- < > Characters appearing in angular brackets are considered to be elements of the language being defined. Their meanings can be found under "Syntax Conventions," unless otherwise specified with the key word definition.
- [] Square brackets indicate that whatever occurs within the brackets is optional.
- | "Or" indicates a choice of exactly one element from a list (for example, <a>| indicates <a> or but not both).
- () Parentheses are used to clarify which elements to choose from.
- Underscore indicates a space must be placed at that location (for example, A_<a> indicates there must be a space between the key word, A, and the element, <a>).
- ::= "Is defined as." For example, <a>::=<c> indicates that <a> can be replaced by the series of elements <c> in any statement where <a> occurs.
- { } Integers appearing in braces indicate that the integer is transmitted to the analyzer as a single 8-bit byte.

Syntax Conventions

<A-block data field>::=	#A<length><command list> (use when the length of the command list is known)
<A-block data format>::=	#A<length><command list>
<amplitude unit>::=	DB DM DBM DBMV DBUV V W
<block data field>::=	<A-block data field> <I-block data field>
<command list>::=	one or more spectrum analyzer commands
<CR>::=	ASCII 13 (carriage return)
<delimiter>::=	<CR> <LF> , ;
<END>::=	end of data transmission
<frequency unit>::=	HZ KZ KHZ MZ MHZ GZ GHZ
<I-block data field>::=	#I<command list>END; (use when the length of the command list is not known)
<integer>::=	positive or negative integer number in the range of -32768 through +32767
<length>::=	two 8-bit bytes specifying the length of the command list
<LF>::=	ASCII 10 (line feed)
<numeric data format>::=	<real><LF><EOI>
<real>::=	positive or negative real number
<string data field>::=	<string delimiter> or <text><string delimiter>
<string delimiter>::=	! " \$ % & ' / : = @ \ ~ `
<terminator>::=	(<amplitude unit> <time unit> <frequency unit>)<delimiter>

<time unit>::=	S SC SEC MS MSEC US
<trace destination>::=	TRA TRB
<trace source>::=	TRA TRB
<trace widow>::=	TRA TRB

4-4 Programming Reference

Programming Codes (functional index)

Programming commands are listed by function in this section. Included are alternate commands common to the HP 8560A/8561B/8563A and the HP 8566A/8568A, which are shown in parentheses ().

Amplitude Control

AT	Specifies input attenuation.
AT AUTO	Couples input attenuation (CA).
AUNITS	Specifies amplitude units for input, output and display.
COUPLE	Selects ac or dc input coupling.
LG	Selects log scale.
LN	Selects linear scale.
MKRL	Moves the active marker amplitude to the reference level (E4).
ML	Specifies mixer level.
RL	Specifies reference level.
RLCAL	Calibrates reference level.
ROFFSET	Specifies reference level offset.

Bandwidth Control

RB	Specifies resolution bandwidth.
RB AUTO	Couples resolution bandwidth (CR).
RBR	Specifies the coupling ratio of resolution bandwidth and frequency span.
VB	Specifies video bandwidth.
VB AUTO	Couples video bandwidth (CV).
VBR	Specifies coupling ratio of video bandwidth and resolution bandwidth.

Coupling Control

AUTOCP	Auto-couple all controls.
AT AUTO	Auto-couple the input attenuator (CA).
RB AUTO	Auto-couple resolution bandwidth (CR).
SS AUTO	Auto-couple center frequency step-size (CS).
ST AUTO	Auto-couple sweep time (CT).

VB AUTO Auto-couple video bandwidth (CV).
RBR Specifies coupling ratio of resolution bandwidth and frequency span.
VBR Specifies coupling ratio of video bandwidth and resolution bandwidth.

Demodulation

DEMOD Demodulation.
DEMODAGC Demodulation automatic gain control.
DEMODT Demodulation time.
SQUELCH Squelch control for demodulation.

Display Control

ANNOT Turns annotation on or off. Preset condition is on.
AUNITS Specifies amplitude units for input, output, and display.
DL Specifies display line level in dBm.
DLE Turns display line on and off (L0).
FDSP Turns all frequency display annotation off. Preset is the only method to turn annotation back on.
GRAT Turns graticule on or off. Preset condition is on.
LG Selects log scale.
LN Selects linear scale.
TH Turns threshold on or off (T0).
TITLE Writes specified ASCII characters in title block area of display.

External Mixing*

CNVLOSS Sets reference level offset to compensate for external mixer conversion loss.
EXTMXR Selects either preselected or unpreselected external mixing mode.
FULBAND Sets start and stop frequencies for full waveguide bands.
HNLOCK Locks to specified harmonic number.
HNUNLK Unlocks the specified harmonic number.
IDCF Sets center frequency to frequency of SIGID.

* Not available with an HP 8560A Option 002.

4-6 Programming Reference

IDFREQ	Returns frequency of identified signal.
MBIAS	Specifies the bias level for external mixers.
MKPX	Specifies minimum excursion for peak identification.
MXRMODE	Specifies either internal or external mixing.
SIGDEL	Specifies the maximum amplitude difference allowed for signal identification.
SIGID	Identifies signals in external mixing frequency bands.

Frequency Control

CF	Specifies center frequency.
SS AUTO	Couples center frequency step size (CS).
FA	Specifies start frequency.
FB	Specifies stop frequency.
FOFFSET	Specifies frequency offset.
FREF	Specifies the frequency reference source.
FS	Specifies full frequency span as defined by instrument state.
FULBAND	Sets the start and stop frequency for full waveguide band (external mixing only).
MKFCR	Specifies resolution of frequency counter.
SP	Specifies frequency span.
SS	Specifies center frequency step size.

Information and Service Diagnostics

ADJALL	Initiates power-on adjustment sequence.
ADJCRT	Initiates CRT adjustment patterns.
ADJIF	Initiates IF adjustment sequence.
ERR?	Returns list of instrument error codes.
ET?	Elapsed time.
FDIAG	Returns frequency of specified oscillator.
ID?	Returns the HP model number of analyzer used (HP 8560A, HP 8561B, or HP 8563A) and any installed options.
PSDAC	Selects preselector peak DAC number.
REV?	Returns analyzer firmware revision date (YYMMDD format).
RLCAL	Permits reference level calibration.
SER?	Returns analyzer serial number.

Instrument State Control

IP	Sets instrument parameters to preset values.
RCLS	Recalls previously saved state (RC).
PSTATE	Protects saved states (save lock).
SAVES	Saves current state of the analyzer in the specified register (SV).

Marker Control

MKA	Returns the amplitude of active marker (MA).
MKCF	Enters marker frequency into center frequency (E2).
MKD	Moves delta marker to specified frequency (M3).
MKDR	Specifies the marker delta reciprocal, read out in time.
MKF	Specifies the frequency of active marker (MF).
MKFC	Counts marker frequency for greater accuracy (See MKFCR).
MKFCR	Specifies resolution of marker frequency counter.
MKMIN	Moves marker to minimum signal detected.
MKN	Moves marker to specified frequency or center screen (M2).
MKNOISE	Average noise value at a marker and normalize to a 1 Hz bandwidth.
MKOFF	Turns the active marker off (M1).
MKPK	Moves marker to signal peak (E1).
MKPT	Specifies marker peak threshold.
MKPX	Specifies minimum excursion for peak identification. Default value is 6 dB.
MKRL	Moves active marker to reference level (E4).
MKSP	Moves marker delta frequency into span.
MKSS	Moves marker frequency to center frequency step size (E3).
MKT	Positions marker at point corresponding to the time from beginning of sweep.
MKTRACK	Turns marker signal track on (MT1) or off (MT0).

Operator Entry

HD Holds or disables data entry and blanks active function CRT readout.

Output Format Control

AUNITS Specifies amplitude units for input, output, and display.
MKA? Returns marker amplitude (MA).
MKF? Returns marker frequency (MF).
SWPOUT Specifies the sweep output.
TRA? Outputs trace A (TA).
TRB? Outputs trace B (TB).
TDF Selects trace data output format as real number parameter units (P) format, binary (B) format, A-block (A) format, I-block (I) format, and measurement units (M) format.

Plotter and Printer Output

OP Returns lower left and upper right vertices of analyzer display.
PLOT Sends analyzer display to a plotter.
PLOTORG Specifies scaling points for plot.
PLOTSRC Specifies plot source.
PRINT Sends the analyzer display to a printer.

Preselector Control

PP Peaks preselector.
PSDAC Specifies preselector peak data.

Service Request

RQS Specifies the decimal weighting of status byte bits which are allowed during service request. Set to 0 with power up or device clear.
SRQ Sets service request if operand bits are allowed by RQS.
STB Returns the decimal equivalent of the bits set in the status byte.

Bit	Decimal	Definition
7	—	Not used.
6	64	Request service.
5	32	Error present in error register.
4	16	Command complete
3	—	Not used.
2	4	End of sweep.
1	2	Message occurred.
0	0	Cleared.

Sweep and Trigger Control

CONTS Selects continuous sweep mode (S1).
ST Specifies sweep time.
ST AUTO Couples sweep time.
SNGLS Selects single sweep mode (S2).
TM Selects trigger mode: free run (T1), video (T4), line (T2), external (T3).
TS Takes a sweep.
VTL Sets the video trigger level.

Synchronization

TS Takes a sweep.
DONE? Returns a 1 when task has been completed.

Trace Functions

Processing

BLANK Stores and blanks specified trace register (A4|B4).
CLRW Clear-writes specified trace register (A1|B1).
MINH Holds the minimum trace register values.
MXMH Holds the maximum trace register values (A2|B2).
RCLT Recalls specified trace data.

4-10 Programming Reference

SAVET	Saves specified trace data.
TRA	Inputs or outputs trace A.
TRB	Inputs or outputs trace B.
VIEW	Views specified trace register (A3 B3).

Math

AMB	Performs A-B into A (C1 C2).
AMBPL	Performs A-B+DL into A.
APB	Performs A+B into A.
AXB	Exchanges A and B (EX).
BML	Performs B-DL into B (BL).
VAVG	Turns video averaging on or off.

Other

AUNITS	Specifies amplitude units for input, output, and display.
DET	Specifies video detector type.

Tracking Generator Control

NORMLIZE	Activates normalization routine.
NRL	Sets the normalized reference level.
NRPOS	Adjusts the normalized reference position.
RCLOSCAL	Recalls stored open/short trace calibration data.
RCLTHRU	Recalls stored thru calibration data.
RL	Adjusts the range level.
SRCALC*	Selects internal or external leveling.
SRCRSTK*	Coarse-tunes the tracking generator oscillator.
SRCFINTK*	Fine-tunes the tracking generator oscillator.
SRCPOFS*	Offsets displayed tracking-generator source power.
SRCPSTP*	Sets the step size of the source power level.
SRCPSWP*	Controls the power-sweep function.
SRCPWR*	Controls the output power of the tracking generator.
SRCTKPK*	Peaks the tracking generator response.
STOREOPEN	Saves open reference data for use with STORESHORT.
STORESHORT	Averages shorted and open reference data and saves the average.

* HP 8560A Option 002 only.

STORETHRU Stores thru-reference data.
SWPCPL Selects a stimulus response or spectrum analyzer auto-coupled sweep time equation.

User Measurements

FFT Performs a discrete Fourier transform.
PWRBW Returns the bandwidth equal to a percentage of total power.
TWNDOW Creates a trace array for the FFT function.

Programming Codes (alphabetical index)

—A—

ADJALL;

Initiates the LO and IF alignment routines.
OUTPUT 718;"ADJALL;IP;"

ADJCRT;

Turns on CRT adjustment patterns. Execute IP when adjustment is complete.
OUTPUT 718;"ADJCRT;"

ADJIF_ON|OFF|1|0|FULL|CURR|?;

Activates constant IF adjustment sequence.
Default is on.
OUTPUT 718;"ADJIF OFF;"

Query response: 1|0
OUTPUT 718;"ADJIF?;"
ENTER 718;Adjif

AMB_ON|OFF|1|0|?;

Subtracts trace B from trace A and sends the result to trace A.
OUTPUT 718;"CLRW TRB;TS;VIEW TRB;TS;AMB ON;"

Query response: 1|0
OUTPUT 718;"AMB?;"
ENTER 718;Amb

AMBPL_ON|OFF|1|0|?;

Subtracts trace B from trace A, adds the display line value to the difference, and sends the result to trace A.

OUTPUT 718;"CLRW TRB;TS;VIEW TRB;DL -50DBM;"

OUTPUT 718;"AMBL ON;"

Query response: 1|0

OUTPUT 718;"AMBPL?;"

ENTER 718;Ambpl

ANNOT_ON|OFF|1|0|?;

Turns the display annotation on or off.

IP turns on the annotation.

OUTPUT 718;"ANNOT OFF;"

Query response: 1|0

OUTPUT 718;"ANNOT?;"

ENTER 718;Annot

APB;

Adds trace A and trace B and sends the result to trace A.

OUTPUT 718;"VIEW TRA;CLRW TRB;TS;VIEW TRB;"

OUTPUT 718;"APB;"

AT_(<integer>DB)|UP|DN|EP|MAN|AUTO|?;

Specifies the RF input attenuation, in dB.

<integer>::=0 through 70

UP/DN increment::=10 dB

OUTPUT 718;"AT 30 DB;"

OUTPUT 718;"AT UP;"

Query response: <integer>

OUTPUT 718;"AT AUTO;"

OUTPUT 718;"AT?;"

ENTER 718;Atten

AUNITS_<amplitude units>|AUTO|MAN|?;

Specifies the amplitude units for input, output and display.

OUTPUT 718;"AUNITS DBUV;"

OUTPUT 718;"AUNITS AUTO;"

Query response: <amplitude units>

OUTPUT 718;"AUNITS?;"

ENTER 718;Units\$

AUTOCPL;

Auto-couple all controls.

OUTPUT 718;"AUTOCP L;"

AXB;

Exchanges trace A and trace B.

OUTPUT 718;"AXB;"

—B—

BLANK_TRA|TRB;

Stores and blanks the specified trace register.

OUTPUT 718;"BLANK TRB;"

BML;

Subtracts the display line from trace B and sends the result to trace B.

OUTPUT 718;"DL -30 DBM;CLR W TRB;TS;"

OUTPUT 718;"BML;"

CF_(<real><frequency units>)|UP|DN|EP|?;
Specifies the center frequency. Default units are Hz.
UP/DN increment::=10% of span or step size
OUTPUT 718;"CF 2.750 GHZ;"
OUTPUT 718;"CF DN;"
Query response: <numeric data format>
OUTPUT 718;"CF?;"
ENTER 718;Freq

CLRW_TRA|TRB;
Clear-writes the specified trace register.
OUTPUT 718;"CLRW TRA;"

CNVLOSS_(<real>DB)|UP|DN|EP|?;
Specifies the conversion loss of an external mixer used to extend the analyzer frequency range.
UP/DN increment::=0.1 db
OUTPUT 718;"CNVLOSS 24.5 DB;"
OUTPUT 718;"CNVLOSS DN;"
Query response: <numeric data format>
OUTPUT 718;"CNVLOSS?;"
ENTER 718;Mixer_loss

CONTS;
Selects continuous sweep mode.
Selected with IP.
OUTPUT 718;"SP 10 MHZ;CONTS;"

COUPLE.AC|DC|?;

Sets the input coupling to ac or dc coupling. Default is ac.
(Not available with an HP 8563A.)

OUTPUT 718;"COUPLE AC;"

Query response: AC|DC

OUTPUT 718;COUPLE?;"

ENTER 718;Couple\$

—D—

DEMOD_FM|AM|OFF|?;

Selects FM or AM demod and turns demodulation off.

OUTPUT 718;"DEMOD FM;"

OUTPUT 718;"DEMOD OFF;"

Query response: FM|AM|OFF

OUTPUT 718;"DEMOD?;"

ENTER 718;Demod\$

DEMODAGC_ON|OFF|1|0|?;

Turns the demodulation automatic gain control (AGC) on or off. IP turns AGC off.

OUTPUT 718;"DEMODAGC ON;"

Query response: 1|0

OUTPUT 718;"DEMODAGC?;"

ENTER 718;Demodagc

DEMODT_(<real><time units>)|UP|DN|EP|?;

Selects the time the sweep pauses at marker for demodulation of signal
UP/DN increment::=1,2,5,10 sequence

OUTPUT 718;"DEMODT 10 SC;"

Query response: <numeric data format>

OUTPUT 718;"DEMODT?;"

ENTER 718;Delay

DET_POS|NEG|NRM|SMP|?;

Selects the specified analyzer video detection.

OUTPUT 718;"DET POS;"

Query response: POS|NEG|NRM|SMP

OUTPUT 718;"DET?;"

ENTER 718;Det\$

DL_(<real><amplitude units>)|UP|DN|ON|OFF|EP|?;

Specifies a line level that is displayed on the CRT.

UP/DN increment::=1 vertical division

OUTPUT 718;"DL -25 DBM;"

Query response: <numeric data format>

OUTPUT 718;"DL?;"

ENTER 718;Line

<command list>;[TS;]DONE[_]?;

This command is a synchronizing function that sends a 1 to the controller after the take sweep has been executed. When TS (take sweep) precedes DONE, execution of the command list is assured before the 1 is returned.

OUTPUT 718;"SP 100 MHZ;TS;DONE?;"

ENTER 718;Done

—E—

ERR?;

Returns to a controller a list of error numbers. Positive numbers are error codes. An error code of 0 means there are no errors.

Query response: <integer><,><LF><EOI>

OUTPUT 718;"ERR?;"

ENTER 718; Err\$

PRINT Err\$

ET?;

Returns the elapsed time of operation in hours. Reset by Hewlett-Packard.

Query response: <numeric data format>

OUTPUT 718;"ET?;"

ENTER 718;Time

EXTMXR_(PRE|UNPR)?;

Specifies external mixing mode.

OUTPUT 718;"EXTMXR PRE;"

Query response: PRE|UNPR

OUTPUT 718;"EXTMXR?;"

ENTER 718;Mxrmode

—F—

FA_(<real><frequency units>)|UP|DN|EP?;

Specifies the start frequency. Default units are Hz.

UP/DN increment::=10% of span

OUTPUT 718;"FA 150 KHZ;"

Query response: <numeric data format>

OUTPUT 718;"FA?"

ENTER 718;Startfreq

FB_(<real><frequency units>)|UP|DN|EP?;

Specifies the stop frequency. Default units are Hz.

UP/DN increment::=10% of span

OUTPUT 718;"FB 540 MHZ;"

Query response: <numeric data format>

OUTPUT 718;"FB?;"

ENTER 718;Stopfreq

FDIAG_(LO|SMP|HARM|MROLL|OROLL|XROLL), ?;

Frequency diagnostic routine. Returns the frequency of the specified oscillator.

OUTPUT 718;"FDIAG LO ?;"

ENTER 718;Lo_freq

FDSP_OFF|?;

Turns all frequency related annotation off. Power-on or preset is the only way to turn frequency annotation back on and no last state is saved under this condition.

OUTPUT 718;"FDSP OFF;CF 12.25 GHZ;"

Query response: 1 if frequency annotation is blanked|0 if shown

OUTPUT 718;"FDISP?;"

ENTER 718;Disp

FFT_<trace destination>,<trace source>,<trace window>;

Performs a discrete Fourier transform on the source trace. Use to transform zero-span AM information into the frequency domain. See also TWINDOW.

OUTPUT 718;"TWINDOW TRA,UNIFORM;TS;"

OUTPUT 718;"FFT TRA,TRB,TRA;"

FOFFSET_(<real><frequency units>)|UP|DN|EP|?;

Specifies the frequency offset for all absolute frequency readouts such as center frequency. Default units are Hz.

UP/DN increment::=20% of span

OUTPUT 718;"FOFFSET 25 MHZ;"

Query response: <numeric data format>

OUTPUT 718;"FOFFSET?;"

ENTER 718;Offset

FREF_INT|EXT|?;

Specifies the frequency reference source.

OUTPUT 718;"FREF INT;"

Query response: INT|EXT

OUTPUT 718;"FREF ?;"

ENTER 718;Freqref

FS;

Selects the full frequency span as defined by the instrument.
OUTPUT 718;"CF 1.5 GHZ;FS;"

FULBAND_K|A|Q|U|V|E|W|F|D|G|Y|J;

Selects the full frequency span for the external mixing frequency band the analyzer is currently tuned to (for example, 26.5 to 40.0 GHz equals band A)

OUTPUT 718;"MXRMODE EXT;FULBAND Q;"

Band	Frequency Range	Mixing Harmonic	Conversion Loss
6 (K)	18.6—26.5 GHz	6— (External)	30 dB
7 (A)	26.5—40.0 GHz	8— (External)	30 dB
8 (Q)	33.0—50.0 GHz	10— (External)	30 dB
9 (U)	40.0—60.0 GHz	10— (External)	30 dB
10 (V)	50.0—75.0 GHz	14— (External)	30 dB
11 (E)	60.0—90.0 GHz	16— (External)	30 dB
12 (W)	75.5—110.0 GHz	18— (External)	30 dB
13 (F)	90.0—140.0 GHz	24— (External)	30 dB
14 (D)	110.0—170.0 GHz	30— (External)	30 dB
15 (G)	140.0—220.0 GHz	36— (External)	30 dB
16 (Y)	170.0—260.0 GHz	44— (External)	30 dB
17 (J)	220.0—325.0 GHz	54— (External)	30 dB

—G—

GRAT_ON|OFF|1|0|?;

Turns the graticule on or off. IP turns on the graticule.

OUTPUT 718;"GRAT OFF;"

Query response: 1|0

OUTPUT 718;"GRAT?;"

ENTER 718;Grat

—H—

HD;

Holds or disables data entry and blanks the active function readout.
OUTPUT 718;"CF 14 GHZ;TS;HD;"

HNLOCK_<integer> |ON|OFF|UP|DN|?;

Locks the specified harmonic number to prevent multi-harmonic sweeps.
<integer>::= 1 through 50
UP/DN increment::=1
OUTPUT 718;"MXRMODE EXT;HNLOCK 8;"

Query response: <integer>

OUTPUT 718;"HNLOCK ?;"
ENTER 718;Harmonic_lock

HNUNLK;

Unlocks the harmonic number.
OUTPUT 718;"HNUNLK;CF 65 GHZ;HNLOCK ON;"

—I—

ID[-]?;

Returns the HP model number of the analyzer being used
(HP 8560A or 8561B) and any options installed.

DIM ID\$[50]
OUTPUT 718;"ID?;"
ENTER 718;ID\$

IDCF;

Sets the center frequency (CF) to the frequency of the signal identified
by the SIGID function.

OUTPUT 718;"MKPK HI;SIGID AUTO;IDCF;"

IDFREQ[.];

Returns to the controller the frequency of the identified signal.

Returns 0 if invalid signal identification.

OUTPUT 718;"SIGID AUTO;IDFREQ?;"

ENTER 718; Sig_freq

IP;

Sets instrument parameters to their preset values.

OUTPUT 718;"IP;CF 100MHZ;SP 1MHZ;TS;"

—L—

LG_(<integer>DB)|UP|DN|EP|?;

Specifies the scale of the logarithmic display in 10, 5, 2, or 1 dB/div.

Default units are dB, and 10 dB per division is selected with IP.

<integer>::=1|2|5|10

UP/DN increment::=1, 2, 5, 10 sequence

OUTPUT 718;"LG 2 DB;"

OUTPUT 718;"IP;LG DN DN;"

Query response::=<integer>

A query response of zero indicates a linear scale.

OUTPUT 718;"LG ?;"

ENTER 718;Log_scale

LN;

Selects the linear scale.

OUTPUT 718;"RL -30 DBM;LN;"

MBIAS_(<real>A|MA|UA)|ON|OFF|UP|DN|EP|?;

Selects the bias level for external mixers that require diode bias for efficient mixer operation.

<real>::= -10 to 10

UP/DN increment::=0.01 mA

OUTPUT 718;"MXRMODE EXT;HNLOCK A;MBIAS 20 MA;"

Query response: <numeric data format>

OUTPUT 718;"MBIAS ?;"

ENTER 718;Mixer_bias

MINH_TRA|TRB;

Similar to MAX HOLD except that the minimum trace values are stored.

OUTPUT 718;"CLRW TRA;MINH TRA;"

MKA[.]?;

Returns the amplitude of the active marker. Default units are dBm.

Note: Because MKA returns only a numeric value, know the amplitude units in use (see AUNITS).

Query response: <numeric data format>

OUTPUT 718;"SNGLS;TS;MKPK HI;MKA?;"

ENTER 718;Amptd

MKCF;

Moves the active marker to the center frequency.

OUTPUT 718;"CF 600 MHZ;SP 1 GHZ;"

OUTPUT 718;"TS;MKPK HI;MKCF;TS;"

MKD_(**<real><frequency units>**)|UP|DN|EP|?;

Places a second marker at the specified frequency from the active marker. Frequency may be positive or negative. Default units are Hz. In zero frequency span the units are time.

UP/DN increment::=10% of span

OUTPUT 718;"CF 450 MHZ;SP 400 MHZ;"

OUTPUT 718;"TS;MKPK HI;MKD 300 MHZ;"

Query response: <numeric data format>

OUTPUT 718;"MKPK HI;MKD;MKPK NH:MKD?;"

ENTER 718;Marker_del

MKDR_(**<real><frequency units>**|**<time units>**)|EP|?;

Reads the reciprocal of marker delta, which is the time period between markers. In zero frequency span the units are frequency.

OUTPUT 718;"TS;MKPK HI;MKD;MKPK NH;MKDR;"

Query response: <numeric data format>

OUTPUT 718;"TS;MKPK HI;MKD;MKPK NH;MKDR?;"

ENTER 718;Period

MKF_(**<real><frequency units>**)|EP|?;

Specifies the frequency of the active marker. Default units are Hz.

OUTPUT 718;"CF 450 MHZ;SP 400 MHZ;MKF 600 MHZ;"

Query response: <numeric data format>

OUTPUT 718;"TS;MKPK HI;MKF?;"

ENTER 718;Mfreq

MKFC_ON|OFF;

Counts the marker frequency for a more accurate readout of the marker frequency. The resolution is determined by the MKFCR command.

OUTPUT 718;"MKPK HI;MKFC ON;TS;MKF?;"

ENTER 718;Freq_count

MKFCR_(**<real><frequency units>**)|EP|?;

Specifies the resolution of the marker frequency counter.

OUTPUT 718;"MKFCR 100 HZ;MKFC ON;"

Query response: <numeric data format>

OUTPUT 718;"MKFCR?;"

ENTER 718;Count_res

MKMIN;

Moves the active marker to the minimum signal detected.
OUTPUT 718;"TS;MKPK HI;MKD;MKMIN;"

MKN_[(<real><frequency units>|<time units>)]UP|DN|EP|?];

Moves the active marker to the specified frequency. Default units are Hz.

UP/DN increment::=10% of span

OUTPUT 718;"TS;MKN;"

OUTPUT 718;"CF 100 MHZ;SP 100 MHZ;TS;MKN 75 MHZ;"

Query response: <numeric data format>

OUTPUT 718;"MKPK HI;MKN?;"

ENTER 718;Marker

MKNOISE_ON|OFF|1|0|?];

Calculates the average value at the marker, normalized to a 1 Hz bandwidth, after correction for resolution bandwidth and detection mode (log or linear).

OUTPUT 718;"TS;MKMIN;MKNOISE ON;MKA?;"

ENTER 718;Amptd

Query response: 1|0

OUTPUT 718;"MKNOISE?;"

ENTER 718;Mknoise

MKOFF[_ALL];

Turns the active marker, or all markers, off.

OUTPUT 718;"MKOFF;"

MKPK_HI|NH|NR|NL;

Moves the active marker to the maximum signal detected or to the next highest, next right, or next left signal detected. Marker defaults to maximum signal detected.

OUTPUT 718;"TS;MKPK HI;"

OUTPUT 718;"TS;MKPK HI;MKPK NL;"

OUTPUT 718;"TS;MKPK;"

MKPT_<real>DBM|UP|DN|EP|?;

Specifies the marker peak threshold.

UP/DN increment::=10 dB

OUTPUT 718;"MKPT -95 DBM;"

OUTPUT 718;"AUNITS DBUV;MKPT UP;"

Query response: <numeric data format>

OUTPUT 718;"MKPT?;"

ENTER 718;Peak_thresh

MKPX_(<real>DB)|UP|DN|EP|?;

Specifies the minimum excursion for peak identification. Default units are dB. IP selects 6 dB for minimum excursion.

<real>::=values 0.0 through 30.0

UP/DN increment::=10 dB

OUTPUT 718;"MKPX 3DB;TS;MKPK HI;"

Query response: <numeric data format>

OUTPUT 718;"MKPX?;"

ENTER 718;Peak_ex

MKRL;

Moves the active marker to the reference level.

OUTPUT 718;"TS;MKPK HI;MKRL;TS;"

MKSP;

Moves the marker delta frequency into the frequency span.

OUTPUT 718;"TS;MKPK HI;MKD;MKPK NH;MKSP;TS;"

MKSS;

Moves the marker frequency into the center frequency step size.

OUTPUT 718;"TS;MKPK HI;MKSS;CF UP UP;"

MKT_<real><time units>|?;

Sets the marker to the position corresponding to the sweep time from the beginning of sweep.

OUTPUT 718;"ST 2 SEC;MKT 1.6 SEC;"

Query response: <real>

OUTPUT 718;"MKT ?;"

ENTER 718;Mkr_time

MKTRACK_ON|OFF|1|0|?;

Turns the marker signal track ON or OFF.

OUTPUT 718;"CF 300 MHZ;SP 100 MHZ;"

OUTPUT 718;"MKPK HI;MKTRACK ON;"

OUTPUT 718;"SP 100 KHZ;MKTRACK OFF;"

Query response: 1|0

OUTPUT 718;"MKTRACK?;"

ENTER 718;Track\$

ML_(<integer>DBM)|UP|DN|EP|?;

Specifies the mixer level. Default units are dBm.

<integer>::=-10 through -80

UP/DN increment::=10 dB

OUTPUT 718;"ML - DBM;"

OUTPUT 718;"ML 60 DBUV;"

OUTPUT 718;"ML 10 DBMV;"

Query response: <integer>

OUTPUT 718;"ML?;"

ENTER 718;Mixer_|v|

MXMH_TRA|TRB;

Updates each trace element with the maximum level detected.

OUTPUT 718;"CLRW TRA;CLRW TRB;MXMH TRA;"

}
}
}
} MXRMODE INT|EXT|?;

Specifies an external or internal mixer mode.

OUTPUT 718;"MXRMODE EXT;"

Query response: INT|EXT

OUTPUT 718;"MXRMODE?;"

ENTER 718; Mode\$

—N—

}
}
}
} NORMLIZE_ON|OFF|1|0|?;

Activates the normalization routine for stimulus-response measurements.

Trace B is subtracted from trace A, offset by the normalized reference level (NRL), and the result is sent to trace A. See also STOREOPEN and STORETHRU.

!assumes a valid reference trace is stored

OUTPUT 718;"NORMLIZE ON;TS;DONE?;"

ENTER 718;Done

Query response: <numeric data format>

OUTPUT 718;"NORMLIZE?;"

ENTER 718;Normalized

}
}
}
} NRL_(<real>DB)|?;

Sets the normalized reference level.

OUTPUT 718;"IP;SNGLS;"

OUTPUT 718;"NRL -10DB;TS;DONE?;"

ENTER 718;Done

END

Query response: <numeric data format>

OUTPUT 718;"NRL?;"

ENTER 718;Nref_lvl

NRPOS_<real>|UP|DN|EP|?;
Adjusts the normalized reference position.
OUTPUT 718;"IP;SNGLS;"
OUTPUT 178;"NRPOS 5;TS;DONE?;"
ENTER 718;Done
Query response: <numeric data format>
OUTPUT 718;"NRPOS?;"
ENTER 718;Pos

—0—

OP?;
Returns the parameters which represent the dimensions of the lower left
and upper right vertices of the analyzer display in plotter units.
Response = "P1x, P1y, P2x, P2y;"
Default is "72, 16, 712, 766;"
OUTPUT 718;"OP?;"
ENTER 718;P1x,P1y,P2x,P2y

PLOT[_P1x,P1y,P2x,P2y];

Plots the analyzer display on any HP-IB plotter. P1x and P1y::=plotter dependent values that specify the lower left plotter dimension. P2x and P2y::=plotter dependent values that specify the upper right plotter dimension.

Default is current plotter P1, P2 settings.

DIM Param_string\$[200]

Sel_code=7

Plt_addr=5

Sa_addrs=18

Param_string\$=VAL\$(P1x)&","VAL\$(P1y)&","VAL\$(P2x)&","
VAL\$(P2y)&";"

OUTPUT 718;"PLOT "Param_string\$

SEND Sel_code;UNT UNL LISTEN Plt_addr TALK Sa_addrs DATA

PLOTORG_DSP|GRT|?;

Specifies whether plotter P1, P2 settings are the origin for the graticule or the entire spectrum analyzer display. Allows plotting trace data on paper with preprinted graticule lines.

OUTPUT 718;"PLOTORG GRT;PLOT;"

SEND Sel_code;UNT UNL LISTEN Plt_addr TALK Sa_addrs DATA

Query response: DSP|GRT

OUTPUT 718;"PLOTORG?;"

ENTER 718;Origin\$

PLOTSRC_ALL|TRA|TRB|GRT|ANNT|?;

Specifies the source for PLOT.

Default is ALL.

OUTPUT 718;"PLOTORG GRT;PLOTSRC TRA;"

OUTPUT 718;"PLOTORG DSP;PLOTSRC ALL;"

OUTPUT 718;"PLOTORG GRT;PLOTSRC ANNT;PLOTSRC TRB;"

Query response: ALL|TRA|TRB|GRT|ANNT

OUTPUT 718;"PLOTSRC?;"

ENTER 718;Source\$

PP;

Peaks the preselector. HP 8561B only.

OUTPUT 718;"CF 5 GHZ;SP 100 MHZ;

OUTPUT 718;"TS;MKPK HI;MKCF;SP 10 MHZ;TS;PP;"

PRINT_1|0;

Sends the display contents to a printer. Select 0 for a monochrome printer, 1 for a color format (used with an HP PaintJet printer).

Sel_code=7

Prt_addrs=1

Sa_addrs=18

OUTPUT 718;"PRINT 0;"

SEND Sel_code;UNT UNL LISTEN Prt_addrs TALK Sa_addrs DATA

PSDAC_<integer>|UP|DN|EP|?;

Specifies the preselector peak DAC setting.

<integer>::=0 through 255

UP/DN increment::=1

OUTPUT 718;"PSDAC 35;"

Query response: <integer>

OUTPUT 718;"PSDAC?;"

ENTER 718;Presel_dac

PSTATE_ON|OFF|1|0|?;

Protect state (save lock.)

OUTPUT 718;"SAVES 2;PSTATE ON;"

OUTPUT 718;"PSTATE OFF;SAVES 4;"

Query response: 1|0

OUTPUT 718;"PSTATE ?;"

ENTER 718;Pstate

PWRBW_<trace source>,<real>;

Returns the bandwidth equal to the specified percentage of total power in a trace.

OUTPUT 718;"PWRBW TRA,99?;"

ENTER 718;Pwrbw

RB_(<real><frequency units>)|UP|DN|EP|AUTO|MAN|?;

Specifies the resolution bandwidth.

<real>::=10 Hz to 2 MHz

UP/DN increment::= 1, 3, 10 sequence

OUTPUT 718;"SP 1 MHZ;RB 1 MHZ;TS;"

Query response: <numeric data format>

OUTPUT 718;"RB UP UP;RB?;"

ENTER 718;Res_bw

RBR_([+<real>)|UP|DN|EP|?;

Specifies the ratio between the resolution bandwidth and the frequency span. If the span is changed, the resolution bandwidth will change to maintain the ratio.

<real>::=.002 to .100

UP/DN increment::= 2, 5, 10 sequence

OUTPUT 718;"RBR .3;SP 100KHZ;TS;"

Query response: <numeric data format>

OUTPUT 718;"RBR DN DN DN;RBR ?;"

ENTER 718;Rbw_ratio

RCLOSCAL;

Recalls averaged open/short reference trace data into trace B.

!assume a valid reference trace is stored

OUTPUT 718;"IP;"

OUTPUT 718;"RCLSOCAL;TS;DONE?;"

ENTER 718;Done

OUTPUT 718;"NORMLIZE ON;TS;DONE?;"

ENTER 718;Done

LOCAL 718

RCLS_<integer>|LAST|PWRON;
 Recalls a previously saved state stored in registers 0 through 9, the last instrument state, or the power-on state.
 <integer>::=0 through 9
 OUTPUT 718;"IP;RCLS 2;"
 OUTPUT 718;"CF 10MHZ;SP 1MHZ;TS;IP;RCLS LAST;"

RCLT_(TRA|TRB),<integer>;
 Recalls a previously saved trace stored in registers 0 through 7.
 <integer>::= 0 through 7
 OUTPUT 718;"CLRW TRA;VIEW TRB;"
 OUTPUT 718;"RCLT TRB,4;"

RCLTHRU;
 Recalls a thru-reference trace into trace B.
 !assumes a valid thru trace is stored.
 OUTPUT 718;"RCLTHRU;TS;DONE?;"
 ENTER 718;Done
 OUTPUT 718;"NORMLIZE ON;TS;DONE?;"
 ENTER 718;Done

REV?
 Returns the firmware revision number of the analyzer. Number returned is in the date format of "YYMMDD".
 Query response: <numeric data format>
 OUTPUT 718;"REV?;"
 ENTER 718;Revision

RL_(<real><amplitude units>)|UP|DN|EP|?;
 Specifies the reference level or range level. Default units are dBm.
 UP/DN increment::=Log scale/div or 10 dB in linear scale
 OUTPUT 718;"CF 300MHZ;SP 1MHZ;RL -10DBM;TS;"
 Query response: <numeric data format>
 OUTPUT 718;"TS;MKPK HI;MKRL;TS;"
 ENTER 718;Ref_lvl

RLCAL_<integer>|?;
Calibrates reference level.
<integer>::= -33 through +33
OUTPUT 718;"RLCAL ";Rl_cal
Query response: <integer>
OUTPUT 718;"RLCAL ?;"
ENTER 718;Rl_cal

ROFFSET_(<real>DB)|UP|DN|EP|?;
Specifies the reference level offset. Default units are dB.
UP/DN increment::= Log scale/div or 10 dB in linear scale
OUTPUT 718;"ROFFSET -20DB;"
Query response: <numeric data format>
OUTPUT 718;"ROFFSET?;"
ENTER 718;Ret_offset

RQS_<integer>|?;
Specifies a mask which allows the bits that are not masked for service request.
<integer>::= 0 through 255
OUTPUT 718;"RQS 16;"
OUTPUT 718;"RQS 4;"
OUTPUT 718;"RQS 20;"
Query response: returns the decimal weighting of the status byte bits which are enabled during a service request.
OUTPUT 718;"RQS?;"
ENTER 718;Rqs

—S—

SAVES_<integer>|PWRON;
Saves the current state of the analyzer in the specified state register.
<integer>::= 0 through 9
OUTPUT 718;"CF 20MHZ;SAVES 3;IP;"

SAVET_(TRA|TRB),<integer>;

Saves the current trace of the analyzer in the specified trace register.
<integer>::= 0 through 7

OUTPUT 718;"CLRW TRB;TS;SAVET TRB,4;"

SER?;

Returns the serial number of the spectrum analyzer to the controller.

OUTPUT 718;"SER?;"

ENTER 718;Serial_number\$

SIGID_AUTO|MAN|OFF?;

Identifies signals for the external mixing frequency bands.

OUTPUT 718;"TS;MKPK HI;MKRL;SIGID AUTO;"

Query response: 0 = OFF or AUTO, 1 = MAN

OUTPUT 718;"SIGID?;"

ENTER 718;Status

SNGLS;

Selects single sweep mode.

OUTPUT 718;"IP;CF 100MHZ;SP 1MHZ;SNGLS;TS;"

SP_(<real><amplitude units>)|FULL|ZERO|LAST|UP|DN|EP|?;

Specifies the frequency span. Default units are Hz.

UP/DN increment::=1,2,5 sequence

OUTPUT 718;"CF 10MHZ;SP DN DN;"

OUTPUT 718;"TS;MKPK HI;MKTRACK ON;SP 100KHZ;TS;MKTRACK OFF;"

Query response: <numeric data format>

OUTPUT 718;"SP UP UP;SP?;"

ENTER 718;Span

SQUELCH (<real><amplitude units>)|ON|OFF|UP|DN|EP|?;
Squelch for demodulation.
UP/DN increment ::= Log scale/div or 10 dB in linear scale
OUTPUT 718;"DEMOD AM;SQUELCH -80 DBM;"
Query response: <numeric data format>
OUTPUT 718;"SQUELCH?;"
ENTER 718;Squelch

SRCALC_INT|EXT|?;
Selects internal or external leveling. For use with the HP 8560A Option 002 tracking generator.
OUTPUT 718;"IP;SNGLS;TS;CF 300MHZ;SP 1MHZ;"
OUTPUT 718;"SRCALC EXT;"
Query response: INT|EXT
OUTPUT 718;"SRCALC?;"
ENTER 718;Alc\$

SRCRSTK_<integer>|UP|DN|EP|?;
Adjusts the coarse tuning of the HP 8560A Option 002 Tracking Generator oscillator.
<integer> ::= 0 to 255
OUTPUT 718;SCR PWR ON;SWPCPL SR;RB 10KHZ;"
OUTPUT 718;"TS:DONE?;"
Enter 718;Done
OUTPUT 718;"SRCRSTK EP;"
PAUSE
Query response: <integer>
OUTPUT 718;"SRCRSTK?;"
ENTER 718;Tuning

SRCFINTK_<integer>|UP|DN|EP|?;
Adjusts the fine tuning of the HP 8560A Option 002 tracking generator oscillator.

<integer>::= 0 to 255

OUTPUT 718;SRCPWR ON;SWPCPL SR;RB 10KHZ;"

OUTPUT 718;"TS:DONE?;"

Enter 718;Done

OUTPUT 718;"SRCFINTK EP;"

PAUSE

Query response: <integer>

OUTPUT 718;"SRCFINTK?;"

ENTER 718;Tuning

SRCPOFS_(<real>DB)|UP|DN|EP|?;

Offsets the displayed power of the tracking generator to compensate for tracking generator test condition gains and losses.

<real>::= -100 to 100

OUTPUT 718;"SRCPWR -10DBM;SRCPSWP 10DB;TS;"

INPUT "ENTER THE GAIN OF THE PREAMP UNDER TEST",Gain

OUTPUT 718;"SRCPOFS ";Gain;"DB;"

Query response: <numeric data format>

OUTPUT 718;"SRCPOFS?;"

ENTER 718;Offset

SRCSTP_(<real>DB)|UP|DN|EP|?;

Sets the step size of the source power offset, level, and sweep range.

<real>::= 0.1 to 12.75

UP/DN increment::= 0.1 dB steps

OUTPUT 718;"SRCPWR -10DBM;SRCSTP 1DB;TS;"

Query response: <numeric data format>

OUTPUT 718;"SRCSTP?;"

ENTER 718;Step

SRCPSWP_(**<real>**DB)|UP|DN|EP|?;

Sweeps the output power of the tracking generator over the chosen power-sweep range.

<real>::= 0 to 12.75

UP/DN increment::= 0.1 dB

OUTPUT ;718;;"SRCPWR -10DBM;SRCPSWP 10DB;TS;"

Query response: **<numeric data format>**

OUTPUT 718;"SRCPSWP?;"

ENTER 718;Psweep

SRCPWR_(**<real>****<amplitude units>**)ON|OFF|UP|DN|EP|?;

Activates the output power of the HP 8560A Option 002 Tracking Generator.

<real>::= -10 to 2.8

OUTPUT 718;"SRCPWR ON;TS;DONE?;"

ENTER 718;Done

Query response: 1|0

OUTPUT 718;"SRCPWR?;"

ENTER 718;Srcpower

SRQ_**<integer>**;

Sets a service request if the operand bits are allowed by RQS.

<integer>::= 0 through 255

OUTPUT 718;"RQS 4;SRQ 4;"

SS_(**<real>****<frequency units>**)|AUTO|MAN|UP|DN|EP|?;

Specifies the center frequency step size.

Default units are Hz.

UP/DN increment::=1,2,5 sequence

OUTPUT 718;"CF 100MHZ;SS 100MHZ;"

Query response: **<numeric data format>**

OUTPUT 718;"TS;MKPK HI;MKSS;SS?;"

ENTER 718;Step_size

ST_(<real><time units>)|UP|DN|EP|AUTO|MAN|?;

Specifies the sweep time.

Default units are seconds.

UP/DN increment::= 1,2,5 sequence

OUTPUT 718;"CF 20MHZ;SP 10MHZ;ST UP UP;"

OUTPUT 718;"ST 5SEC;"

Query response: <numeric data format>

OUTPUT 718;"SP 100KHZ;ST?;"

ENTER 718;Sweep_time

STB?;

Status byte query returns to the controller the decimal equivalent of the bits set in the status byte.

OUTPUT 718;"RQS 20;SRQ 20;"

Repeat: !

OUTPUT 718;"STB?"

ENTER 718;Status

IF Status < > 20 THEN GOTO Repeat

STOREOPEN;

Saves the current instrument state and trace A in memory. Use STOREOPEN with STORESHORT to obtain an averaged open/short calibration trace.

OUTPUT 718;"IP;SNGLS;FA 300KHZ;FB 1GHZ;SRCPWR ON;SWPCPL SR;"

PRINT "CONNECT OPEN. PRESS CONTINUE TO STORE OPEN DATA."

PAUSE

OUTPUT 718;"TS;DONE?;"

ENTER 718;Done

OUTPUT 718;"STOREOPEN;"

OUTPUT 718;"TS;DONE?;"

ENTER 718;Done

STORESHORT;

Averages the current data in trace A with open data stored using STOREOPEN, then stores it in state register 8. To ensure valid averaged data, the instrument state must be the same when STOREOPEN and STORESHORT are executed.

!example continued from STOREOPEN

```
PRINT "CONNECT SHORT. PRESS CONTINUE TO AVERAGE AND STORE DATA"
```

```
PAUSE
```

```
OUTPUT 718;"TS;DONE?;"
```

```
ENTER 718;Done
```

```
OUTPUT 718;"STORESHORT;TS;DONE?;"
```

```
ENTER 718;Done
```

STORETHRU;

Stores a thru calibration trace in trace B and in state register 9.

```
OUTPUT 718;"IP;SNGLS;FA 300KHZ;FB 1GHZ;SRCPWR ON;SWPCPL SR;"
```

```
PRINT "CONNECT THRU. PRESS CONTINUE TO STORE DATA."
```

```
PAUSE
```

```
OUTPUT 718;"SRCTKPK;TS;DONE?;"
```

```
ENTER 718;Done
```

```
OUTPUT 718;"STORETHRU;TS;DONE?;"
```

```
ENTER 718;Done
```

SWPCPL_SR|SA|?;

Selects a stimulus response (SR) or spectrum analyzer (SA) sweep time equation.

```
OUTPUT 718;"SRCPWR ON;SWPCPL SR;TS;"
```

Query response: SR|SA

```
OUTPUT 718;"SWPCPL?;"
```

```
ENTER 718,Swpcpl$
```

```

SWPOUT_RAMP|FAV|?;
  Select the sweep output at J8.
  RAMP::= sweep ramp 0 to 10 volts
  FAV::= frequency analog voltage
  0.5 volt/GHz.
  OUTPUT 718;"SWPOUT RAMP;"
Query response: RAMP|FAV
  OUTPUT 718;"SWPOUT ?;"
  ENTER 718;Sweep$

```

—T—

```

TDF_A|B|I|M|P|?;
  Formats trace information for return to a controller. IP selects P.
  A::= specifies A-block format
  B::= specifies binary data format
  I::= specifies I-block data format
  M::= specifies ASCII data format
  P::= specifies real number output format. Numbers are Hz, volts, watts,
  dBm, dB $\mu$ V, dBV, or seconds.
  OUTPUT 718;"TS;VIEW TRA;TDF P:TRA?;"
Query response: P|B
  OUTPUT 718;"TDF?;"
  ENTER 718;Format$

```

```

TH_(<real><amplitude units>)|ON|OFF|UP|DN|EP|?;
  Blanks signal responses below the specified threshold level. Default units
  are dBm.
  UP/DN increment::= Log scale/div or 10 dB in linear scale
  OUTPUT 718;"TH -75DBM;"
  OUTPUT 718;"TH OFF;"
Query response: <numeric data format>
  OUTPUT 718;"TH?;"
  ENTER 718;Threshold

```

TITLE_<string data field>;

Sets the analyzer to title mode where characters called from the analyzer character set appear near the upper right-hand corner of the display. Up to two 16-character lines can be displayed.

```
OUTPUT 718;"TITLE%This is a sample";
```

```
OUTPUT 718;"title, two lines%";
```

TM_FREE|VID|LINE|EXT|?;

Selects the trigger mode.

```
OUTPUT 718;"TM LINE";
```

```
OUTPUT 718;"TM FREE";
```

Query response: FREE|VID|LINE|EXT

```
OUTPUT 718;"TM ?";
```

```
ENTER 718;Trigger$
```

TRA_<block data field>|?;

Input or output 601 data points to or from trace A. (See TDF.) Places trace A in view mode before trace data transfer.

```
DIM A(0:600)
```

```
OUTPUT 718;"SNGLS;TS;TDF P;TRA ";
```

```
FOR I=0 TO 599
```

```
OUTPUT 718;A(I);"DBM,";
```

```
NEXT I
```

```
OUTPUT 718;A(600);"DBM;"
```

Query response: <block data field>

```
DIM B(0:600)
```

```
OUTPUT 718;:"TDF P;TRA?";
```

```
ENTER 718;B(*)
```

```

TRB.<block data field>|?;
    Input or output 601 data points to or from trace B. (See TDF.) Places
    trace B in view mode before trace data transfer.
    INTEGER A(0:600)
    OUTPUT 718;"SNGLS;TS;TDF B;TRB ";
    OUTPUT 718 USING "#,W";A(*)
Query response: <block data field>
    INTEGER A(0:600)
    OUTPUT 718;"TDF B;TRB?;"
    ENTER 718 using "#,W";A(*)
    OUTPUT 718;"RL?;"
    ENTER 718;Ref_lvl
    OUTPUT 718;"LG ?;"
    ENTER 718;Scale
    FOR X=0 TO 600
        A(X)=Ref_lvl+Scale*(A(X)/60-10)
    NEXT X

TS;
    Takes a sweep.
    OUTPUT 718;"SNGLS;CF 10MHZ;SP 1MHZ;TS;"

TWINDOW.<trace destination>,<window>;
    Creates a window trace array for the FFT function. The window is a
    weighting function that forces the ends of FFT input data smoothly to
    zero. This reduces step discontinuity and measurement error.
    <window>::= FLATTOP|HANNING|UNIFORM
    OUTPUT 718;"TWINDOW TRA,UNIFORM;TS;"
    OUTPUT 718;"FFT TRA,TRB,TRA;"

```

VAVG_<integer>|ON|OFF|UP|DN|EP|?;
Turns the video averaging on or off.
<integer>::= represents the maximum number of sweeps executed for averaging. Default is 100.
UP/DN increment::=1
OUTPUT 718;"VAVG 10;"
Query response: <integer>
OUTPUT 718;"VAVG ?;"
ENTER 718;Vid_avg

VB_(<real><frequency units>)|UP|DN|AUTO|MAN|EP|?;
Specifies the video bandwidth. Default units are Hz.
<real>::= 1 Hz to 3 MHz
UP/DN increment::= 1,3 10 sequence
OUTPUT 718;"RB 10KHZ;VB DN;"
OUTPUT 718;"VB 1HZ;"
Query response: <numeric data format>
OUTPUT 718;"RB 100KHZ;VB UP UP;VB?;"
ENTER 718;Video_bw

VBR_<real>|UP|DN|EP|?;
Specifies the ratio between the video bandwidth and the resolution bandwidth. When the resolution bandwidth is changed, the video bandwidth changes to maintain the ratio. For example, an entry of 0.3 sets the video bandwidth one bandwidth step lower than the resolution bandwidth.
<real>::= .003 to 3.00
UP/DN increment::= 1,3 10 sequence
OUTPUT 718;"VBR 3;RB 10KHZ;"
Query response: <numeric data format>
OUTPUT 718;"VBR DN DN;VBR?;"
ENTER 718;"Video_ratio

VIEW_TRA|TRB;

Stores and views the specified trace.

OUTPUT 718;"CLRW TRA;TS;VIEW TRA;"

VTL_<real><amplitude units>|UP|DN|EP|?;

Sets the level for video trigger.

UP/DN increment::=Log scale/div or 10 dB in linear scale

OUTPUT 718;"TM VID;VTL -55 DBM;"

Query response: <numeric data format>

OUTPUT 718;"VTL ?;"

ENTER 718;Trig_lvl

Secondary Key Word Summary

A	ampere (unit); A-block data format; external mixer frequency band
AC	alternating current (coupling)
ALL	all (marker off, plot screen, if adjust)
AM	amplitude modulation (DEMODO)
ANNT	annotation
AUTO	automatic operation
B	8-bit byte output format
CURR	current (IF adjustment)
D	external mixer frequency band
DC	direct current (coupling)
DB	relative decibel (unit)
DBM	absolute decibel milliwatt (unit)
DBMV	absolute decibel millivolt (unit)
DBUV	absolute decibel microvolt (unit)
DM	absolute decibel milliwatt (unit)
DN	decrement the parameter
DSP	display
E	external mixer frequency band
EP	enable parameter for front panel operator entry. The analyzer remains in "remote" mode but permits manual entry of the data via the data keys, the step keys, the knob. Press HOLD after using the data keys or the step keys.
EXT	external
F	external mixer frequency band
FAV	frequency analog voltage (sweep output)
FLATTOP	FFT window format
FM	frequency modulation (DEMODO)
FREE	free run
FULL	full band span width
G	external mixer frequency band
GHZ	gigahertz (unit)
GRT	graticule
GZ	gigahertz (unit)

HANNING	FFT window format
HARM	harmonic number (frequency diagnostic)
HI	highest
HZ	hertz
I	I-block data format
INT	internal (reference, mixer mode)
J	external mixer frequency band
K	external mixer frequency band
KHZ	kilohertz (unit)
KZ	kilohertz (unit)
LAST	previous state before a change
LAST SPAN	previous span before a change
LINE	line, as in line trigger
LO	local oscillator (frequency diagnostic)
M	ASCII display data output format
MA	milliamp (unit)
MAN	manual operation
MHZ	megahertz (unit)
MS	millisecond (unit)
MSEC	millisecond (unit)
MROLL	main roller oscillator (frequency diagnostic)
MV	millivolt (unit)
MW	milliwatt (unit)
MZ	megahertz (unit)
NEG	negative peak detection
NH	next highest
NL	next left
NR	next right
NRM	normal rosenfell detection
OA	function query (same as "?")
OFF	turn function off
ON	turn function on
OROLL	offset roller oscillator (frequency diagnostic)
P	real number output format
POS	positive peak detection
PRE	preselected external mixer mode

PWRON	sets same state as turning power on
Q	external mixer frequency band
RAMP	sweep ramp voltage (sweep output)
S	second (unit)
SA	spectrum analyzer (sweep time coupling)
SC	second (unit)
SEC	second (unit)
SMP	sample detection, sampling oscillator (frequency diagnostic)
SR	stimulus response (sweep time coupling)
TRA	trace A
TRB	trace B
U	external mixer frequency band
UA	microamp (unit)
UNIFORM	FFT window format
UNPR	unpreselected external mixer mode
UP	increment the parameter
UV	microvolt (unit)
US	microsecond (unit)
V	volt (unit); external mixer frequency band
VID	video
W	watt (unit); external mixer frequency band
XROLL	transfer roller oscillator (frequency diagnostic)
Y	external mixer frequency band
ZERO	zero span
0	off
1	on
?	returns a query response containing the value or state of the associated parameter (same as OA)

Error Messages

This appendix lists the error messages that can appear during spectrum analyzer operation. Next to each message is a description of the error. Error messages are combined into several general categories:

- Series 100 errors indicate incorrect spectrum analyzer programming via HP-IB. These error messages are described in Table A-1.
- Series 200 and 300 errors indicate hardware or firmware failure.
- Series 400 and 500 errors indicate IF alignment failure. The automatic alignment routine adjusts amplitude parameters first, then resolution bandwidths in this sequence: 300 kHz, 1 MHz, 2 MHz, 100 kHz, 30 kHz, 10 kHz, 3 kHz, 1 kHz, 300 Hz, 100 Hz, 30 Hz, and 10 Hz. The routine restarts from the beginning if a fault is detected. Errors labeled "AMPL" imply amplitude accuracy failure. Errors labeled "RBW" imply resolution bandwidth and amplitude accuracy problems. Parameters adjusted after the routine begins and before the fault is detected should be acceptable; parameters adjusted later in the sequence are suspect. Thus, bandwidth values in the error message indicate that the displayed bandwidth or a narrower bandwidth may have poor shape or gain accuracy.
- Series 600 and 700 errors indicate failure in hardware and firmware interaction or indicate checksum error.
- Series 800 errors indicate failure in an option module.
- Series 900 errors indicate incorrect data entry or user operation that resulted in measurement error. These errors are described in Table A-2.

For a complete listing of all error messages, refer to either Appendix E of the *HP 8560A/8561B/8563A Portable Spectrum Analyzers Operating and Programming Manual* or Chapter 5, "Error Messages," of any of the portable spectrum analyzer Installation and Verification Manuals.

The spectrum analyzer displays error messages in the lower left corner of the display and shows one error message at a time. To check for additional errors, press **RECALL** **MORE 1 OF 2** **RECALL ERRORS**. Additional error messages appear in the active function block of the display. Use the step keys to scroll through additional messages. If an error occurs during remote operation, **ERRORS** appears in the softkey menu. Pressing **ERRORS** accesses error messages.

Realigning the LO and IF may eliminate some errors. Press **CAL** and **REALIGN LO & IF** to activate the alignment routines.

Table A-1. Remote Operation Errors

Error Message	Description
ERR 100 NO PWRON	Power-on state is invalid; default state is loaded.
ERR 101 NO STATE	State to be recalled not valid or not saved.
ERR 106 ABORTED!	Current operation is aborted; HP-IB parser reset.
ERR 107 HELLO ??	No HP-IB listener is present.
ERR 108 TIME OUT	Analyzer timed out when acting as controller.
ERR 109 CtrlFail	Analyzer unable to take control of the bus.
ERR 110 NOT CTRL	Analyzer is not system controller.
ERR 111 # ARGMTS	Command does not have enough arguments.
ERR 112 ??CMD??	Unrecognized command.
ERR 113 FREQ NO!	Command cannot have frequency units.
ERR 114 TIME NO!	Command cannot have time units.
ERR 115 AMPL NO!	Command cannot have amplitude units.
ERR 116 ?UNITS??	Unrecognizable units.
ERR 117 NOP NUM	Command cannot have numeric units.
ERR 118 NOP EP	Enable parameter cannot be used.
ERR 119 NOP UPDN	UP/DN are not valid arguments for command.
ERR 120 NOP ONOF	ON/OFF are not valid arguments for command.
ERR 121 NOP ARG	AUTO/MAN are not valid arguments for command.
ERR 122 NOP TRC	Trace registers are not valid for command.
ERR 123 NOP ABLK	A-block format not valid here.
ERR 124 NOP IBLK	I-block format not valid here.
ERR 125 NOP STRNG	Strings are not valid for this command.
ERR 126 NO ?	This command cannot be queried.

A-2 Error Messages

Table A-1. Remote Operation Errors (continued)

Error Message	Description
ERR 127 BAD DTMD	Not a valid peak detector mode.
ERR 128 PK WHAT?	Not a valid peak search parameter.
ERR 129 PRE TERM	Premature A-block termination.
ERR 130 BAD TDF	Arguments are only for TDF command.
ERR 131 ?? AM/FM	AM/FM are not valid arguments for this command.
ERR 132 !FAV/RMP	FAV/RAMP are not valid arguments for this command.
ERR 133 !INT/EXT	INT/EXT are not valid arguments for this command.
ERR 134 ??? ZERO	ZERO is not a valid argument for this command.
ERR 135 ??? CURR	CURR is not a valid argument for this command.
ERR 136 ??? FULL	FULL is not a valid argument for this command.
ERR 137 ??? LAST	LAST is not a valid argument for this command.
ERR 138 !GRT/DSP	GRT/DSP are not valid arguments for this command.
ERR 139 PLOTONLY	Argument can only be used with PLOT command.
ERR 140 ?? PWRON	PWRON is not a valid argument for this command.
ERR 141 BAD ARG	Argument can only be used with FDIAG command.
ERR 142 BAD ARG	Query expected for FDIAG command.
ERR 143 NO PRESL	No preselector hardware for use with a command.

Table A-2. Data and Other User-Generated Errors

Error Message	Description
ERR 900 TG UNLVL	Tracking generator output is unlevelled and the start frequency is greater than 300 kHz. Check the internal/external leveling mode; this error should not appear when internal leveling is used.
ERR 901 TGFrqLmt	Tracking generator output is unlevelled and the start frequency is set below the tracking generator frequency limit of 300 kHz. Set the start frequency to greater than or equal to 300 kHz.
ERR 902 BAD NORM	The state of the stored trace does not match the current state of the analyzer; thus, the normalization is not meaningful.
ERR 903 A > DLMT	Part or all of unnormalized trace A is off screen with trace math or normalization on; thus, part or all of the result is inaccurate.
ERR 904 B > DLMT	Part or all of the calibration trace (trace B) is off screen with trace math or normalization on; thus part or all of the result is inaccurate.

Softkey Cross Reference

This appendix lists the HP 8560A, HP 8561B, and HP 8563A softkeys in alphabetical order. Next to each softkey is the front-panel key under whose menu the softkey is found. Some softkeys are available on certain models only. Access to some marker softkeys may depend on the number of markers in use and the selected frequency span.

Table B-1. Softkey Cross Reference

Softkey	Front-Panel Key
0 → 10V LO SWP	AUX CTRL
0.5 V/GHz (FAV)	AUX CTRL
10 MHz EXT INT	AUX CTRL
A	
A+B → A	TRACE
A-B → A ON OFF	TRACE
A-B+DL → A ON OFF	TRACE
ADJ CURR IF STATE	CAL
A EXCH B	TRACE
AGC ON OFF	AUX CTRL

Table B-1. Softkey Cross Reference (continued)

Softkey	Front-Panel Key
A (continued)	
ALC INT EXT*†	AUX CTRL
ALL	AUTO COUPLE
AM DEMOD ON OFF	AUX CTRL
AM/FM DEMOD	AUX CTRL
AMPTD CORRECT*	AUX CTRL
AMPTD UNITS	AMPLITUDE
ANALYZER ADDRESS	CONFIG
ANNOT HELP	DISPLAY
ANNOT ON OFF	DISPLAY
ATTEN AUTO MAN ‡	AMPLITUDE, AUTO COUPLE
AVERAGE CNV LOSS*	AUX CTRL
B	
B-DL→B	TRACE
B & W	CONFIG
BACK SPACE	DISPLAY
BIAS*	AUX CTRL
BIAS OFF*	AUX CTRL
BLANK A	TRACE
BLANK B	TRACE
*Not available with an HP 8560A Option 002.	
†Available only with an HP 8560A Option 002.	
‡Available only with internal mixing.	

B-2 Softkey Cross Reference

Table B-1. Softkey Cross Reference (continued)

Softkey	Front-Panel Key
C	
CAL OPN/SHRT	AUX CTRL
CAL THRU	AUX CTRL
CENTER FREQ	FREQUENCY
CF STEP AUTO MAN	FREQUENCY, AUTO COUPLE
CHAR SET 1 2	DISPLAY
CLEAR WRITE A	TRACE
CLEAR WRITE B	TRACE
CNV LOSS VS FREQ *	AUX CTRL
COLOR	CONFIG
CONT	SWEEP, TRIG
COPY DEV PRNT PLT	CONFIG
COUNTER ON OFF	FREQ COUNT
COUNTER RES	FREQ COUNT
COUPLING AC DC	AMPLITUDE
CRT ADJ PATTERN	CAL
D	
DATECODE & OPTIONS	CONFIG
dBm	AMPLITUDE
*Not available with an HP 8560A Option 002.	

Table B-1. Softkey Cross Reference (continued)

Softkey	Front-Panel Key
D (continued)	
dBmV	AMPLITUDE
dBμV	AMPLITUDE
DEMOD TIME	AUX CTRL
DETECTOR MODES	TRACE
DETECTOR NEG PEAK	TRACE
DETECTOR NORMAL	TRACE
DETECTOR POS PEAK	TRACE
DETECTOR SAMPLE	TRACE
DSPL LIN ON OFF	DISPLAY
E	
ELAPSED TIME	RECALL
ERASE TITLE	DISPLAY
EXTERNAL	TRIG
EXTERNAL MIXER *	AUX CTRL
EXT MXR PRE UNPR *	CONFIG
F	
FACTORY PRSEL PK †	RECALL
FFT MEAS	MEAS/USER
FM DEMOD ON OFF	AUX CTRL
*Not available with an HP 8560A Option 002. †Available only with internal mixing.	

B-4 Softkey Cross Reference

Table B-1. Softkey Cross Reference (continued)

Softkey	Front-Panel Key
F (continued) FOCUS FREE RUN FREQ DIAGNOSE FREQ DSP OFF FREQ OFFSET FULL BAND† FULL IF ADJ FULL SPAN	DISPLAY TRIG CAL DISPLAY FREQUENCY AUX CTRL CAL SPAN
G GRAT ON OFF	DISPLAY
I IF ADJ ON OFF INTENSTY INTERNAL MIXER*	CAL DISPLAY AUX CTRL
L LAST SPAN LAST STATE LINE LINEAR	SPAN PRESET , RECALL TRIG AMPLITUDE
*Not available with an HP 8560A Option 002.	

Table B-1. Softkey Cross Reference (continued)

Softkey	Front-Panel Key
L (continued)	
LOCK HARMONIC*	AUX CTRL
LOCK ON OFF*	AUX CTRL
LO FREQ	CAL
LOG dB/DIV	AMPLITUDE
M	
MAIN ROLLER	CAL
MAN TRK ADJ †	AUX CTRL
MARKER → CF	MKR →, PEAK SEARCH
MARKER → CF STEP	MKR →
MARKER → REF LVL	MKR →
MARKER DELTA	AUX CTRL †, FREQ COUNT, MKR, PEAK SEARCH
MARKER 1/DELTA	MKR
MARKER NORMAL	AUX CTRL, FREQ COUNT, MKR, PEAK SEARCH †
MARKERS OFF	MKR
MAX HOLD A	TRACE
MAX HOLD B	TRACE
<p>*Not available with an HP 8560A Option 002. †Available only with an HP 8560A Option 002.</p>	

B-6 Softkey Cross Reference

Table B-1. Softkey Cross Reference (continued)

Softkey	Front-Panel Key
M (continued)	
MAX MKR LEVEL*	AMPLITUDE
MKR $\Delta \rightarrow$ CF †	MKR \rightarrow
MKR $\Delta \rightarrow$ CF STEP †	MKR \rightarrow
MKR $\Delta \rightarrow$ SPAN †	MKR \rightarrow
MKR $1/\Delta \rightarrow$ CF ‡	MKR \rightarrow
MKR $1/\Delta \rightarrow$ CF STEP ‡	MKR \rightarrow
MKRNOISE ON OFF	MKR
N	
NEGATIVE BIAS §	AUX CTRL
NEXT PEAK	AUX CTRL, FREQ COUNT, PEAK SEARCH
NEXT PK LEFT	PEAK SEARCH
NEXT PK RIGHT	PEAK SEARCH
NORMLIZE ON OFF	AUX CTRL, TRACE
NORM REF LVL	AMPLITUDE
NORM REF POSN	AMPLITUDE, AUX CTRL, TRACE
<p>* Available only with internal mixing. † Available when delta marker mode is active. ‡ Available when delta marker mode and zero span are in use. § Not available with an HP 8560A Option 002. Softkey appears only when NORMLIZE ON OFF is set to ON.</p>	

Table B-1. Softkey Cross Reference (continued)

Softkey	Front-Panel Key
O	
OFFSET ROLLER	CAL
P	
PEAK EXCURSM	PEAK SEARCH
PEAK SEARCH	AUX CTRL, FREQ COUNT
PEAK THRESHLD	PEAK SEARCH
PLOT ANNOT	CONFIG
PLOT GRATICUL	CONFIG
PLOT DRG DSP GRAT	CONFIG
PLOTTER ADDRESS	CONFIG
PLOTTER CONFIG	CONFIG
PLOT TRACE A	CONFIG
PLOT TRACE B	CONFIG
POSITIVE BIAS*	AUX CTRL
POWER BANDWDTH	MEAS/USER
POWER ON	RECALL
PRESEL AUTO PK	AMPLITUDE, AUX CTRL
PRESEL MAN ADJ	AMPLITUDE, AUX CTRL
PRESEL PEAK†	AUX CTRL
*Not available with an HP 8560A Option 002. †Available only with <i>preselected</i> external mixing.	

B-8 Softkey Cross Reference

Table B-1. Softkey Cross Reference (continued)

Softkey	Front-Panel Key
P (continued)	
PRINTER ADDRESS	CONFIG
PRINTER CONFIG	CONFIG
PWR ON STATE	SAVE
PWR SWP ON OFF *	AUX CTRL
R	
RANGE LVL †	AMPLITUDE †, AUX CTRL
REW/SPAN RATIO	BW
REALIGN LO & IF	CAL
RECALL ERRORS	RECALL
RECALL OPN/SHRT	AUX CTRL
RECALL PRSEL PK ‡	RECALL
RECALL STATE	RECALL
RECALL THRU	AUX CTRL
RECALL TO TR A	RECALL
RECALL TO TR B	RECALL
REAR PANEL	AUX CTRL
REF LVL	AMPLITUDE
<p>*Available only with an HP 8560A Option 002. †Softkey appears when NORMALIZE ON OFF is set to ON. ‡Available only with preselected external mixing and HP 8561B and HP 8563A internal mixing.</p>	

Table B-1. Softkey Cross Reference (continued)

Softkey	Front-Panel Key
R (continued)	
REF LVL ADJ	CAL
REF LVL OFFSET	AMPLITUDE
RES BW AUTO MAN	AUTO COUPLE, BW
S	
SAMPLER FREQ	CAL
SAMPLER HARMONIC	CAL
SAVELOCK ON OFF	SAVE
SAVE PRSEL PK*	SAVE
SAVE STATE	SAVE
SAVE TRACE A	SAVE
SAVE TRACE B	SAVE
SCREEN TITLE	DISPLAY
SELECT CHAR	DISPLAY
SIG ID AT MKR ††	AUX CTRL
SIG ID → CF ††	AUX CTRL
SID ID ON OFF ††	AUX CTRL
SIGNAL IDENT ††	AUX CTRL
SIG TRK ON OFF	MKR
<p>*Available only with preselected external mixing and HP 8561B and HP 8563A internal mixing. †Not available with an HP 8560A Option 002. ††Available only with <i>unpreselected</i> external mixing.</p>	

B-10 Softkey Cross Reference

Table B-1. Softkey Cross Reference (continued)

Softkey	Front-Panel Key
S (continued)	
SINGLE	SWEEP, TRIG
SOURCE CAL MENU	AUX CTRL
SPACE	DISPLAY
SPAN	SPAN
SPAN ZOOM	SPAN
SQUELCH ON OFF	AUX CTRL
SRC PWR OFFSET*	AUX CTRL
SRC PWR ON OFF*	AUX CTRL
SRC PWR STP SIZE*	AUX CTRL
START FREQ	FREQUENCY
STOP FREQ	FREQUENCY
SWP CPL SR SA	AUX CTRL
SWP TIME AUTO MAN	AUTO COUPLE, SWEEP
T	
THRESHLD ON OFF	DISPLAY
TITLE DONE	DISPLAY
TRACE A B	TRACE
TRACKING GENRATOR	AUX CTRL
*Available only with an HP 8560A Option 002.	

Table B-1. Softkey Cross Reference (continued)

Softkey	Front-Panel Key
T (continued)	
TRACKING PEAK*	AUX CTRL
TRANSFER ROLLER	CAL
U	
UNITS AUTO MAN	AMPLITUDE, AUTO COUPLE
V	
VBW/RBW RATIO	BW
VID AVG ON OFF	BW, TRACE
VIDEO	TRIG
VIDEO BW AUTO MAN	AUTO COUPLE, BW
VIEW A	TRACE
VIEW B	TRACE
VOLTS	AMPLITUDE
W	
WATTS	AMPLITUDE
Z	
ZERD SPAN	SPAN
*Available only with an HP 8560A Option 002.	

Key versus Programming Command Cross Reference

This appendix lists the HP 8560A, HP 8561B, and HP 8563A keys in alphabetical order. Next to a key is the related programming command. In some cases, a key has no corresponding programming command.

Table C-1. Softkey Cross Reference

Key	Programming Command
0→10V LO SWP	SWPOUT
0.5 V/GHz (FAV)	SWPOUT
10 MHz EXT INT	FREF
A	
A+B →A	APB
A-B →A ON OFF	AMB
A-B+DL →A ON OFF	AMBPL
A EXCH B	AXB
ADJ CURR IF STATE	ADJIF
AGC ON OFF	DEMODAGC
ALC INT EXT	SRCALC
ALL	AUTOCPPL
AM DEMOD ON OFF	DEMOD

Table C-1. Softkey Cross Reference (continued)

Key	Programming Command
A (continued)	
AM/FM DEMOD	—
AMPLITUDE	RL
ANPTD CORRECT	—
ANPTD UNITS	AUNITS
ANALYZER ADDRESS	—
ANNOT HELP	—
ANNOT ON OFF	ANNOT
ATTEN AUTO MAN	AT
AVERAGE CNV LOSS	CNVLOSS
AUTO COUPLE	—
AUX CTRL	—
B	
B-DL→B	BML
B & W	PRINT
BACK SPACE	—
BIAS	MBIAS
BIAS OFF	MBIAS
BLANK A	BLANK
BLANK B	BLANK
BW	RB

C-2 Key versus Programming Command Cross Reference

Table C-1. Softkey Cross Reference (continued)

Key	Programming Command
C	
CAL	—
CAL OPN/SHRT	STOREOPEN, STORESHORT
CAL THRU	STORETHRU
CENTER FREQ	CF
CF STEP AUTO MAN	SS
CHAR SET 1 2	—
CLEAR WRITE A	CLRW
CLEAR WRITE B	CLRW
CNV LOSS VS FREQ	—
COLOR	PRINT
CONFIG	—
CONT	CONTS
COPY	PLOT, PRINT
COPY DEV PRNT PLT	—
COUNTER ON OFF	MKFC
COUNTER RES	MKFCR
COUPLING AC DC	COUPLE
CRT ADJ PATTERN	ADJCRT

Table C-1. Softkey Cross Reference (continued)

Key	Programming Command
D	
DATECODE & OPTIONS	ID, REV, SER
dB μ V	AUNITS
dBm	AUNITS
dBmV	AUNITS
DEMOD TIME	DEMODT
DETECTOR MODES	—
DETECTOR NEG PEAK	DET
DETECTOR NORMAL	DET
DETECTOR POS PEAK	DET
DETECTOR SAMPLE	DET
DSPL LIN ON OFF	DL
DISPLAY	—
E	
ELAPSED TIME	ET
ERASE TITLE	—
EXTERNAL	TM
EXTERNAL MIXER	MXRMODE
EXT MXR PRE UNPR	EXTMXR
F	
FACTORY PRSEL PK	—
FFT MEAS	FFT

Table C-1. Softkey Cross Reference (continued)

Key	Programming Command
F (continued)	
FM DEMOD ON OFF	DEMOMD
FOCUS	—
FREE RUN	TM
FREQ COUNT	MKFC
FREQ DIAGNOSE	FDIAG
FREQ DSP OFF	FDSP
FREQ OFFSET	FOFFSET
FREQUENCY	CF
FULL BAND	FULBAND
FULL IF ADJ	ADJIF
FULL SPAN	FS
G	
GRAT ON OFF	GRAT
H	
HOLD	HD
I	
IF ADJ ON OFF	ADJIF
INTENSTY	—
INTERNAL MIXER	MXRMODE

Table C-1. Softkey Cross Reference (continued)

Key	Programming Command
L	
LAST SPAN	—
LAST STATE	RCLS
LINE	TM
LINEAR	LN
LOCK HARMONIC	HNLOCK
LOCK ON OFF	HNLOCK, HNUNLK
LO FREQ	FDIAG
LOG dB/DIV	LG
M	
MAIN ROLLER	FDIAG
MAN TRK ADJ	SROCRSTK, SRCFINTK
MARKER → CF	MKCF
MARKER → CF STEP	MKSS
MARKER → REF LVL	MKRL
MARKER DELTA	MKD
MARKER 1/DELTA	MKDR
MARKER NORMAL	MKN
MARKERS OFF	MKOFF
MAX HOLD A	MXMH
MAX HOLD B	MXMH

C-6 Key versus Programming Command Cross Reference

Table C-1. Softkey Cross Reference (continued)

Key	Programming Command
M (continued)	
MAX MR LEVEL	ML
MEAS/USER	—
MKR	MKN
MKR→	MKN
MKR Δ→CF	MKCF
MKR Δ→CF STEP	MKSS
MKR Δ→SPAN	MKSP
MKR 1/Δ→CF	—
MKR 1/Δ→CF STEP	—
MKRNOISE ON OFF	MKNOISE
MODULE	—
N	
NEGATIVE BIAS	MBIAS
NEXT PEAK	MKPK
NEXT PK LEFT	MKPK
NEXT PK RIGHT	MKPK
NORMLIZE ON OFF	NORMLIZE
NORM REF LVL	NRL
NORM REF POSN	NRPOS
O	
OFFSET ROLLER	FDIAG

Table C-1. Softkey Cross Reference (continued)

Key	Programming Command
P	
PEAK EXCURSN	MKPX
PEAK SEARCH	MKPK
PEAK SEARCH	MKPK
PEAK THRSOLD	MKPT
PLOT ANNOT	PLOTSRC
PLOT GRATICUL	PLOTSRC
PLOT DRG DSP GRAT	PLOTORG
PLOTTER ADDRESS	—
PLOTTER CONFIG	PLOTSRC
PLOT TRACE A	PLOTSRC
PLOT TRACE B	PLOTSRC
POSITIVE BIAS	MBIAS
POWER BANDWDTH	PWRBW
POWER ON	RCLS
PRESEL AUTO PK	PP
PRESEL MAN ADJ	PSDAC
PRESEL PEAK	—
PRESET	IP
PRINTER ADDRESS	—
PRINTER CONFIG	—
PWR ON STATE	SAVES
PWR SWP ON OFF	SRCPSWP

C-8 Key versus Programming Command Cross Reference

Table C-1. Softkey Cross Reference (continued)

Key	Programming Command
R	
RANGE LVL	RL
REW/SPAN RATIO	RBR
REALIGN LO & IF	ADJALL
RECALL	—
RECALL ERRORS	ERR
RECALL OPN/SHRT	RCLOSCAL
RECALL PRSEL PK	—
RECALL STATE	RCLS
RECALL THRU	RCLTHRU
RECALL TO TR A	RCLT
RECALL TO TR B	RCLT
REAR PANEL	—
REF LVL	RL
REF LVL ADJ	RLCAL
REF LVL OFFSET	ROFFSET
RES BW AUTO MAN	RB
S	
SAMPLER FREQ	FDIAG
SAMPLER HARMONIC	FDIAG
SAVE	—

Table C-1. Softkey Cross Reference (continued)

Key	Programming Command
S (continued)	
SAVELOCK ON OFF	PSTATE
SAVE PRSEL PK	—
SAVE STATE	SAVES
SAVE TRACE A	SAVET
SAVE TRACE B	SAVET
SCREEN TITLE	TITLE
SELECT CHAR	—
SGL SWP	SNGLS
SIG ID AT MKR	SIGID
SID ID ON OFF	SIGID
SIG ID—CF	IDCF
SIGNAL IDENT	—
SIG TRK ON OFF	MKTRACK
SINGLE	SNGLS
SOURCE CAL MENU	—
SPACE	—
SPAN	SP
SPAN	SP
SQUELCH ON OFF	SQUELCH
SRC PWR OFFSET	SRCPOFS
SRC PWR ON OFF	SRCPWR

Table C-1. Softkey Cross Reference (continued)

Key	Programming Command
S (continued)	
SRC PWR STP SIZE	SRCPSTP
START FREQ	FA
STOP FREQ	FB
SWEEP	ST
SWP CPL SR SA	SWPCPL
SWP TIME AUTO MAN	ST
T	
THRESHLD ON OFF	TH
TITLE DONE	TITLE
TRACE	—
TRACE A B	TRA, TRB
TRACKING GENRATOR	—
TRACKING PEAK	SRCTKPK
TRANSFER ROLLER	FDIAG
TRIG	—
U	
UNITS AUTO MAN	AUNITS
V	
VBW/RBW RATIO	VBR
VID AVG ON OFF	VAVG

Table C-1. Softkey Cross Reference (continued)

Key	Programming Command
V (continued) VIDEO VIDEO BW AUTO MAN VIEW A VIEW B VOLTS	TM, VTL VB VIEW VIEW AUNITS
W WATTS	AUNITS
Z ZERO SPAN	SP

Programming Command versus Key

This appendix lists HP 8560A, HP 8561B, and HP 8563A programming commands. The programming commands are listed in alphabetical order, followed by a brief command name, and (if applicable) the corresponding key.

Table D-1. Command versus Key

Command	Name	Key
ADJALL	Execute LO and IF Adjustments	REALIGN LO & IF
ADJCRT	Adjust CRT Alignment	CRT ADJ PATTERN
ADJIF	Adjust IF	ADJ CURR IF STATE, FULL IF ADJ, IF ADJ ON OFF
AMB	Trace A Minus Trace B	A-B→A ON OFF
AMBPL	Trace A Minus Trace B Plus Display Line	A-B+DL→A ON OFF
ANNOT	Annotation On/Off	ANNOT ON OFF
APB	Trace A Plus Trace B	A+B→A
AT	Input Attenuation	ATTEN AUTO MAN
AUNITS	Absolute Amplitude Units	UNITS AUTO MAN
AUTOCPPL	Autocouple All "AUTO" Functions	ALL
AXB	Trace A Exchange Trace B	A EXCH B
BLANK	Blank Trace	BLANK A, BLANK B

Table D-1. Command versus Key (continued)

Command	Name	Key
BML	Trace B Minus Display Line	B-DL→B
CF	Center Frequency	CENTER FREQ, FREQUENCY
CLRW	Clear/Write Trace	CLEAR WRITE A, CLEAR WRITE B
CNVLOSS	External Mixer Conversion Loss	AVERAGE CNV LOSS
CONTS	Continuous Sweep	CONT
COUPLE	Input Coupling	COUPLING AC DC
DEMODO	Demodulation	AM DEMOD ON OFF, FM DEMOD ON OFF
DEMODAGC	Demodulation Automatic Gain Control	AGC ON OFF
DEMODT	Demodulation Time	DEMOD TIME
DET	Detection Mode	DETECTOR MODES
DL	Display Line	DSPL LIN ON OFF
DONE	Done	—
ERR	Error	RECALL ERRORS
ET	Elapsed Time	ELAPSED TIME
EXTMXR	External Mixer Mode	EXT MXR PRE UNPR
FA	Start Frequency	START FREQ
FB	Stop Frequency	STOP FREQ
FDIAG	Frequency Diagnostics	FREQ DIAGNOSE
FDSP	Frequency Display	FREQ DSP OFF
FFT	Fast Fourier Transform	FFT MEAS

D-2 Programming Command versus Key

Table D-1. Command versus Key (continued)

Command	Name	Key
FOFFSET	Frequency Offset	FREQ OFFSET
FREF	Frequency Reference	10 MHz INT EXT
FS	Full Span	FULL SPAN
FULBAND	Full Band	FULL BAND
GRAT	Graticule On/Off	GRAT ON OFF
HD	Hold	HOLD
HNLOCK	Harmonic Number Lock	LOCK HARMONIC, LOCK ON OFF
HNUNLK	Unlock Harmonic Number	LOCK ON OFF
ID	Output Identification	DATECODE & OPTIONS
IDCF	Signal Identification Frequency to Center Frequency	SIG ID—CF
IDFREQ	Signal Identified Frequency	—
IP	Instrument Preset	PRESET
LG	Logarithmic Amplitude Scale	LOG dB/DIV
LN	Linear Amplitude Scale	LINEAR
MBIAS	Mixer Bias	BIAS OFF, NEGATIVE BIAS, POSITIVE BIAS
MINH	Minimum Trace Hold	—
MKA	Marker Amplitude	—
MKCF	Marker to Center Frequency	MARKER—CF
MKD	Marker Delta	MARKER DELTA
MKDR	Marker Delta Reciprocal	MARKER 1/DELTA

Table D-1. Command versus Key (continued)

Command	Name	Key
MKF	Marker Frequency	—
MKFC	Frequency Counter	COUNTER ON OFF, (FREQ COUNT)
MKFCR	Frequency Counter Resolution	COUNTER RES
MKMIN	Marker to Minimum	—
MKN	Marker Normal	MARKER NORMAL, (MKR), (MKR→)
MKNOISE	Marker Noise	MKRNOISE ON OFF
MKOFF	Markers Off	MARKERS OFF
MKPK	Marker Peak Search	(PEAK SEARCH), PEAK SEARCH
MKPT	Marker Peak Threshold	PEAK THRESHLD
MKPX	Marker Peak Excursion	PEAK EXCURSN
MKRL	Marker to Reference Level	MARKER—REF LVL
MKSP	Marker Delta to Span	MKR Δ—SPAN
MKSS	Marker to Center Frequency Step-Size	MARKER—CF STEP
MKT	Marker Time	MARKER NORMAL (when span = 0 Hz)
MKTRACK	Signal Track	SIG TRK ON OFF
ML	Mixer Level	MAX MKR LEVEL
MXMH	Maximum Hold	MAX HOLD A, MAX HOLD B
MXRMODE	Mixer Mode	EXTERNAL MIXER, INTERNAL MIXER
NORMLIZE	Normalized Trace Data	NORMLIZE ON OFF

D-4 Programming Command versus Key

Table D-1. Command versus Key (continued)

Command	Name	Key
NRL	Normalize Reference Level	NORM REF LVL
NRPOS	Adjust Normalized Reference Level	NORM REF POSN
OP	Output Display Parameters	—
PLOT	Plot Display	COPY
PLOTORG	Specify Plot Origins	PLOT ORG DSP GRAT
PLOTSRC	Plot Source	PLOTTER CONFIG
PP	Preselector Peak	PRESEL AUTO PK
PRINT	Print Display	COPY
PSDAC	Preselector DAC Number	PRESEL MAN ADJ
PSTATE	Protect State	SAVELOCK ON OFF
PWRBW	Trace Power Bandwidth	POWER BANDWDTH
RB	Resolution Bandwidth	BW, RES BW AUTO MAN
RBR	Resolution Bandwidth to Span Ratio	RBW/SPAN RATIO
RCLOSCAL	Recall Open/Short Average	RECALL OPN/SHRT
RCLS	Recall State Register	RECALL STATE
RCLT	Recall Trace Register	RECALL TO TRA, RECALL TO TRB
RCLTHRU	Recall Thru	RECALL THRU
REV	Output Firmware Revision	DATECODE & OPTIONS
RL	Reference/Range Level	AMPLITUDE, RANGE LVL, REF LVL

Table D-1. Command versus Key (continued)

Command	Name	Key
RLCAL	Reference Level Calibration	REF LVL ADJ
ROFFSET	Reference Amplitude Offset	REF LVL OFFSET
RQS	Request Service Conditions	—
SAVES	Save State	SAVE STATE
SAVET	Save Trace	SAVE TRACE A, SAVE TRACE B
SER	Serial Number	DATECODE & OPTIONS
SIGID	Signal Identify	SIG ID AT MKR, SIG ID ON OFF
SNGLS	Single Sweep	(SGL SWP), SINGLE
SP	Frequency Span	(SPAN), SPAN
SQUELCH	Squelch for Demodulation	SQUELCH ON OFF
SRCALC	Source Leveling Control	ALC INT EXT
SRCRSTK	Coarse Tracking Adjust	MAN TRK ADJ
SRCFINTK	Fine Tracking Adjust	MAN TRK ADJ
SRCPOFS	Source Power Offset	SRC PWR OFFSET
SRCPSTP	Source Power Step-Size	SRC PWR STP SIZE
SRCPSWP	Tracking Generator Power Sweep	PWR SWP ON OFF
SRCPWR	Tracking Generator Output Power	SRC PWR ON OFF
SRCTKPK	Peak Tracking Generator Response	TRACKING PEAK
SRQ	Service Request	—
SS	Center Frequency Step-Size	CF STEP AUTO MAN

Table D-1. Command versus Key (continued)

Command	Name	Key
ST	Sweep Time	SWP TIME AUTO MAN
STB	Status Byte Query	—
STOREOPEN	Store Open	CAL OPN/SHRT
STORESHORT	Store Short	CAL OPN/SHRT
STORETHRU	Store Thru	CAL THRU
SWPCPL	Stimulus-Response Sweep Couple	SWP CPL SR SA
SWPOUT	Sweep Output	0.5 V/GHz (FAV)
TDF	Trace Data Format	—
TH	Threshold	THRESHLD ON OFF
TITLE	Title Entry	SCREEN TITLE
TM	Trigger Mode	TRIG
TRA	Trace A Data Input/Output	—
TRB	Trace B Data Input/Output	—
TS	Take Sweep	—
TWNDOW	Trace window	—
VAVG	Video Average	VID AVG ON OFF
VB	Video Bandwidth	VIDEO BW AUTO MAN
VBR	Video Bandwidth to Resolution Bandwidth Ratio	VBW/RBW RATIO
VIEW	View Trace	VIEW A, VIEW B
VTL	Video Trigger Level	VIDEO

Menu Trees

This appendix illustrates the menus available from the front-panel keys. Access to lower-level menus is also shown.

AMPLITUDE

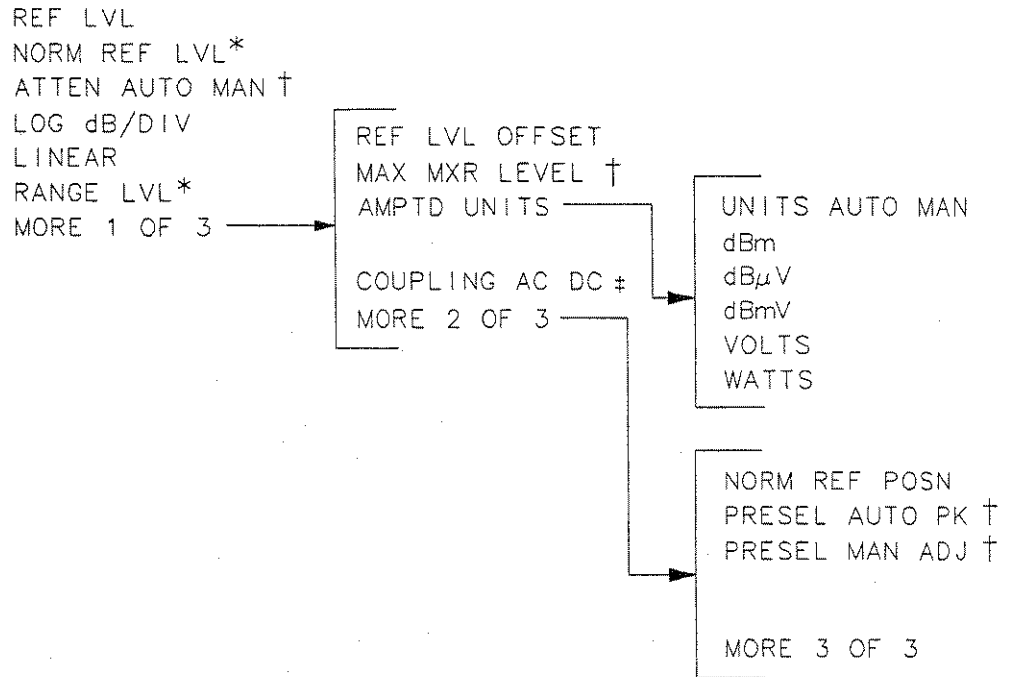

* Appears only when NORMLIZE ON OFF is set to ON.

† Only available with internal mixing.

‡ Not available with an HP 8563A.

**AUTO
COUPLE**

ALL
RES BW AUTO MAN
VIDEO BW AUTO MAN
SWP TIME AUTO MAN
ATTEN AUTO MAN*

CF STEP AUTO MAN
UNITS AUTO MAN

MORE 2 OF 2

* Only available with internal mixing.

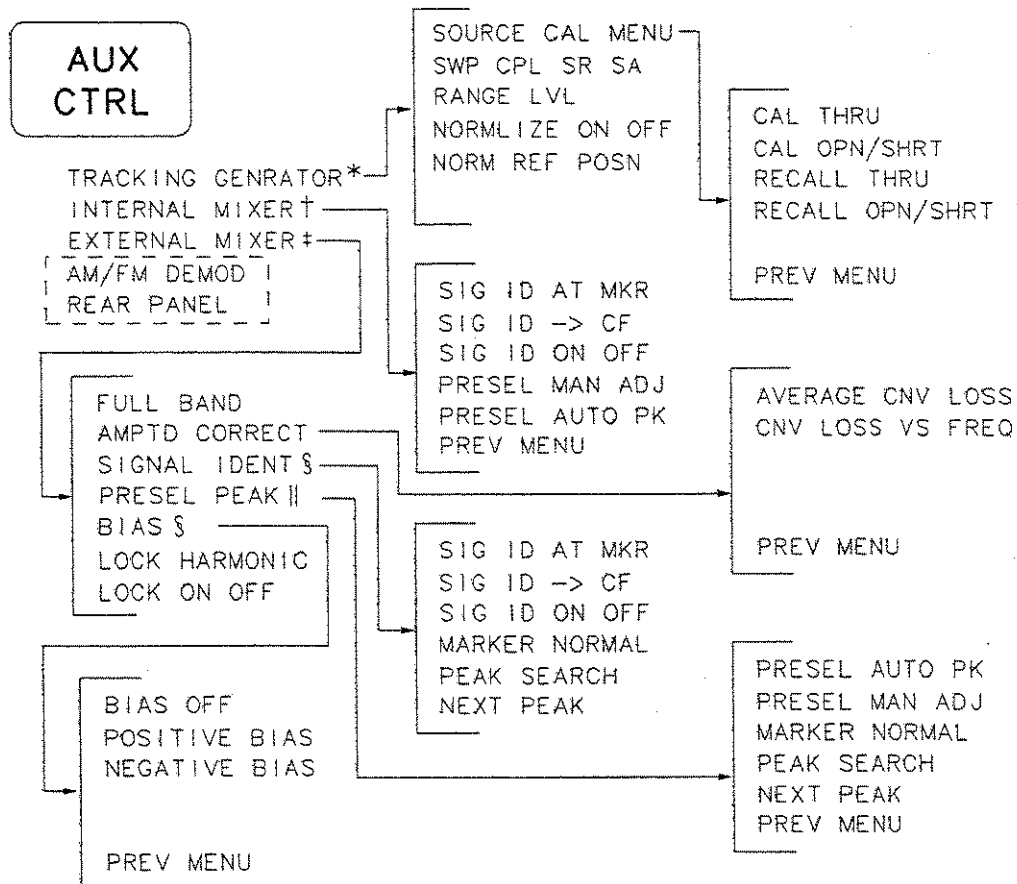

* For use with an external tracking generator only. See next page for built-in tracking generator (HP 8560A Option 002) softkey menu.

† The INTERNAL MIXER softkey and its lower-level softkeys are not available with an HP 8560A Option 002. However, only the INTERNAL MIXER softkey is available with an HP 8560A, its softkey menus are not.

‡ Not available with an HP 8560A Option 002.

§ Available only with unpreselected external mixing.

|| Available only with preselected external mixing.

**AUX
CTRL**

TRACKING GENRATOR
INTERNAL MIXER
EXTERNAL MIXER
AM/FM DEMOD
REAR PANEL

AM DEMOD ON OFF
FM DEMOD ON OFF
MARKER NORMAL
PEAK SEARCH
NEXT PEAK
MORE 1 OF 2

DEMOD TIME
SQUELCH ON OFF
AGC ON OFF

0 -> 10V LO SWP
.5 V/GHz (FAV)
10 MHz EXT INT

MORE 2 OF 2

PREV MENU

TRACKING GENRATOR*
INTERNAL MIXER
EXTERNAL MIXER
AM/FM DEMOD
REAR PANEL

SRC PWR ON OFF
SOURCE CAL MENU
RANGE LVL
NORMLIZE ON OFF
NORM REF POSN
MORE 1 OF 3

CAL THRU
CAL OPN/SHRT
RECALL THRU
RECALL OPN/SHRT

PREV MENU

TRACKING PEAK
MAN TRK ADJ
ALC INT EXT
SWP CPL SR SA
MORE 2 OF 3

PWR SWP ON OFF
SRC PWR STP SIZE
SRC PWR OFFSET

MORE 3 OF 3

* HP 8560A Option 002 softkey menu.

BW

RES BW AUTO MAN
VIDEO BW AUTO MAN
VBW/RBW RATIO
RBW/SPAN RATIO
VID AVG ON OFF

CAL

REALIGN LO & IF
IF ADJ ON OFF
ADJ CURR IF STATE
FULL IF ADJ
REF LVL ADJ
MORE 1 OF 2

CRT ADJ PATTERN
FREQ DIAGNOSE

MORE 2 OF 2

LO FREQ
SAMPLER FREQ
SAMPLER HARMONIC
MAIN ROLLER
OFFSET ROLLER
TRANSFER ROLLER

CONF IG

COPY DEV PRNT PLT
PRINTER CONFIG
PLOTTER CONFIG
ANALYZER ADDRESS
EXT MXR PRE UNPR *
DATECODE &OPTIONS

COLOR
B & W
PRINTER ADDRESS

PREV MENU

PLOT TRACE A
PLOT TRACE B
PLOT GRATICUL
PLOT ANNOT
PLOT ORG DSP GRAT
PLOTTER ADDRESS

* Not available with an HP 8560A Option 002.

COPY

DISPLAY

DSPL LIN ON OFF
THRESHLD ON OFF
SCREEN TITLE

INTENSTY
MORE 1 OF 2

SELECT CHAR
SPACE
BACK SPACE
ERASE TITLE
CHAR SET 1 2
TITLE DONE

GRAT ON OFF
ANNOT ON OFF
ANNOT HELP
FREQ DSP OFF
FOCUS
MORE 2 OF 2

FREQUENCY

CENTER FREQ
START FREQ
STOP FREQ
CF STEP AUTO MAN
FREQ OFFSET

FREQ COUNT

COUNTER ON OFF
COUNTER RES
MARKER NORMAL
MARKER DELTA
PEAK SEARCH
NEXT PEAK

HOLD

MEAS/
USER

FFT MEAS
POWER BANDWIDTH

MKR

MARKER NORMAL
MARKER DELTA
MARKER 1/DELTA
MKRNOISE ON OFF
SIG TRK ON OFF
MARKERS OFF

MKR->

Normal Marker
Span > 0 Hz

MARKER -> CF
MARKER -> REF LVL
MARKER -> CF STEP

Normal Marker
Zero Span

MARKER -> REF LVL

Delta Marker
Span > 0 Hz

MKR Δ -> CF
MKR Δ -> CF STEP
MKR Δ -> SPAN

Delta Marker
Zero Span

MKR $1/\Delta$ -> CF
MKR $1/\Delta$ -> CF STEP

MODULE

PEAK
SEARCH

MARKER -> CF *
MARKER DELTA
NEXT PEAK
NEXT PK RIGHT
NEXT PK LEFT
MORE 1 OF 2

PEAK EXCURSN
PEAK THRESHLD

MORE 2 OF 2

* In zero span, this softkey becomes
MARKER NORMAL.

PRESET

LAST STATE

RECALL

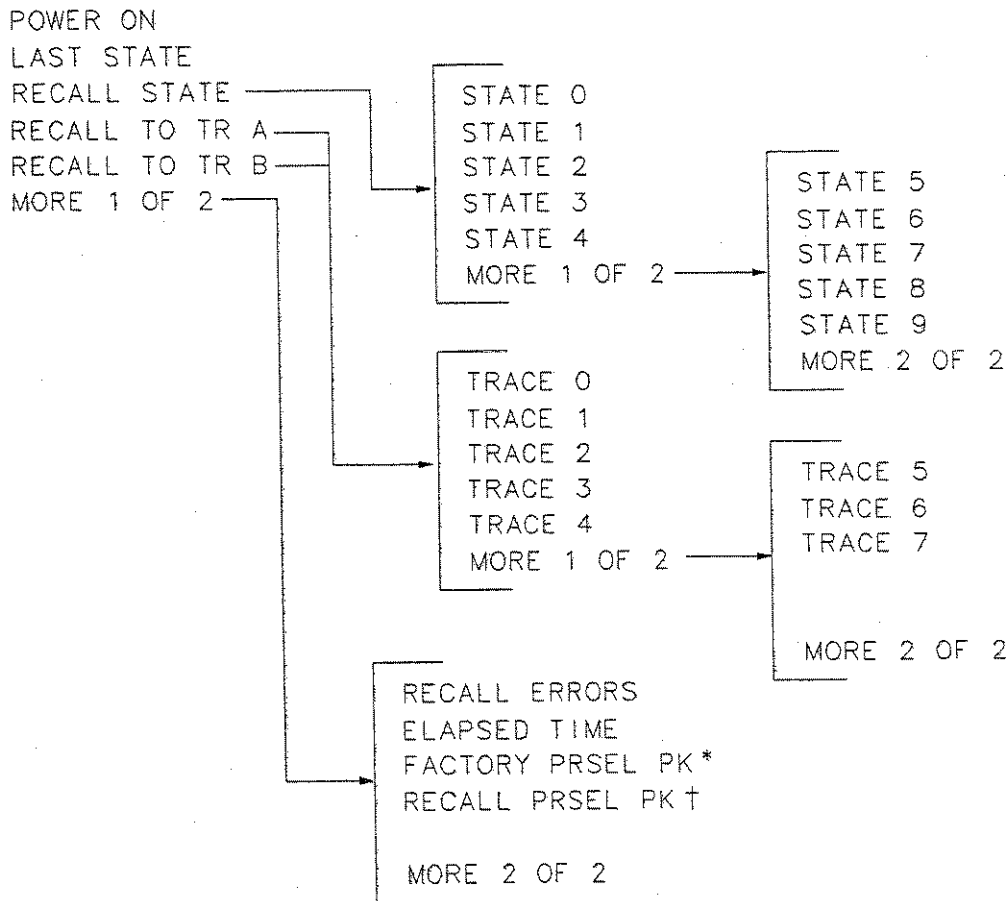

* Available only with internal mixing.

† Available only with preselected external mixing and HP 8561B and HP 8563A internal mixing.

SAVE

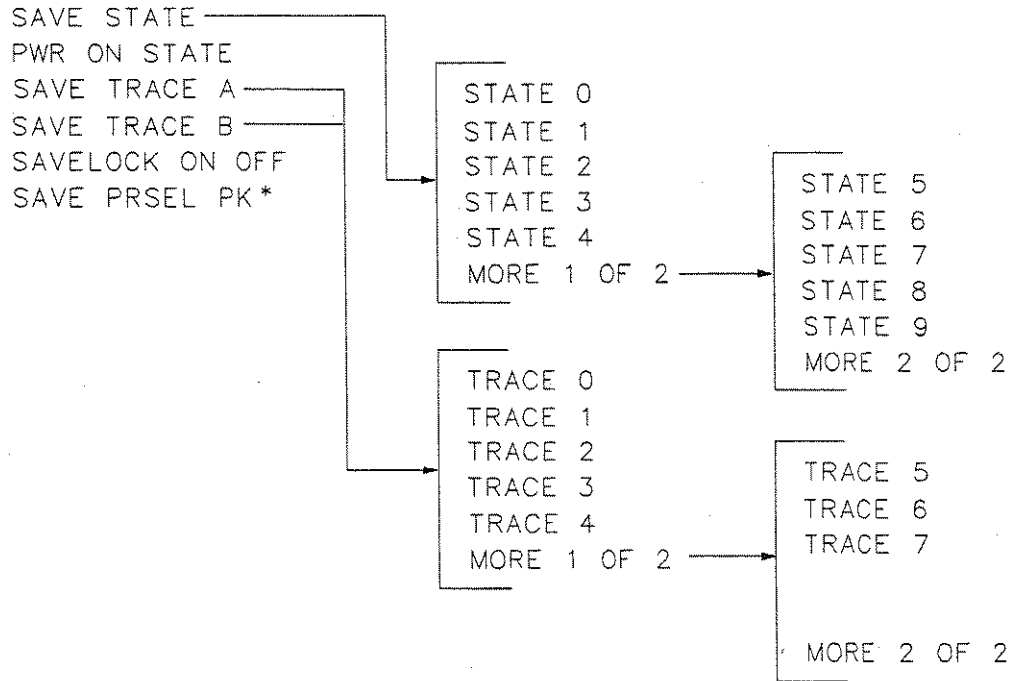

* Available only with preselected external mixing and HP 8561B and HP 8563A internal mixing.

SGL
SWP

SPAN

SPAN
SPAN ZOOM
FULL SPAN
ZERO SPAN
LAST SPAN

SWEEP

SWP TIME AUTO MAN
CONT
SINGLE

TRACE

CLEAR WRITE A
MAX HOLD A
VIEW A
BLANK A
TRACE A B
MORE 1 OF 3

VID AVG ON OFF
DETECTOR MODES
A EXCH B
NORMLIZE ON OFF
NORM REF POSN
MORE 2 OF 3

DETECTOR NORMAL
DETECTOR SAMPLE
DETECTOR POS PEAK
DETECTOR NEG PEAK
PREV MENU

A-B->A ON OFF
A+B->A
B-DL->B
A-B+DL->A ON OFF
MORE 3 OF 3

TRIG

CONT
SINGLE
FREE RUN
VIDEO
LINE
EXTERNAL

Block Diagrams

F-2 Block Diagrams

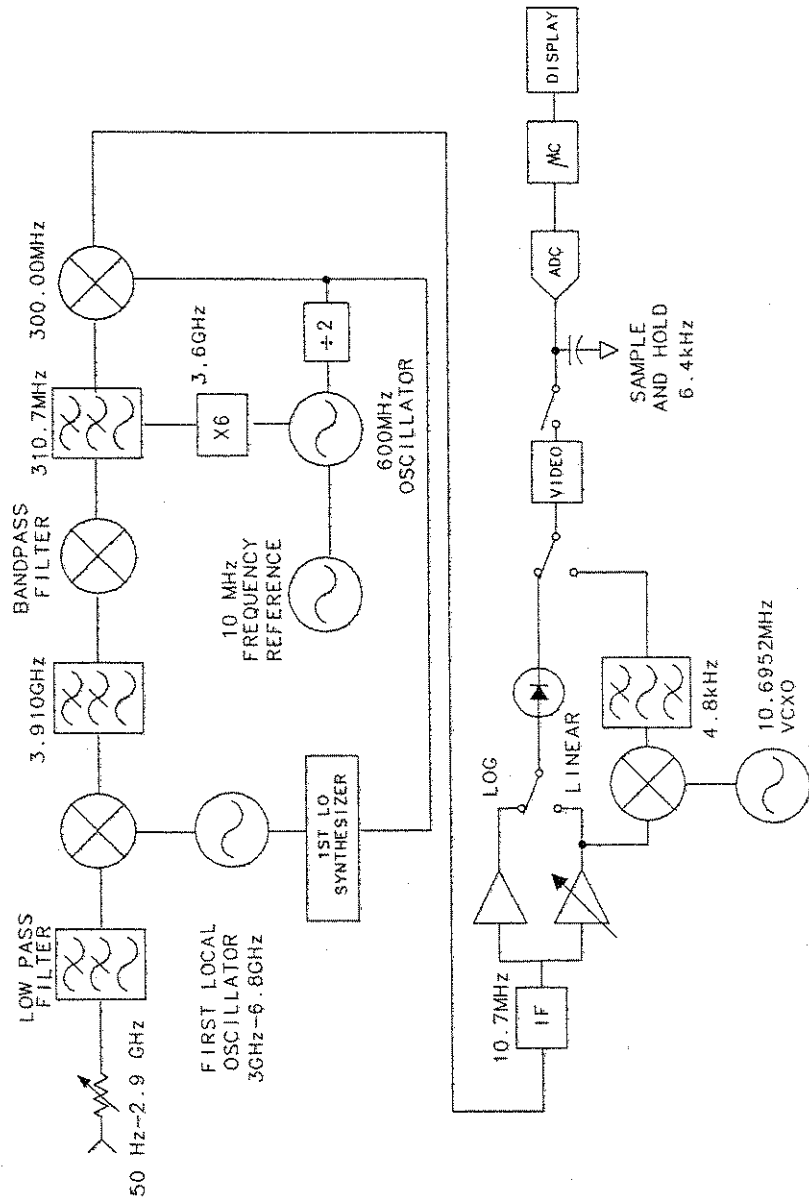

HP 8560A Block Diagram

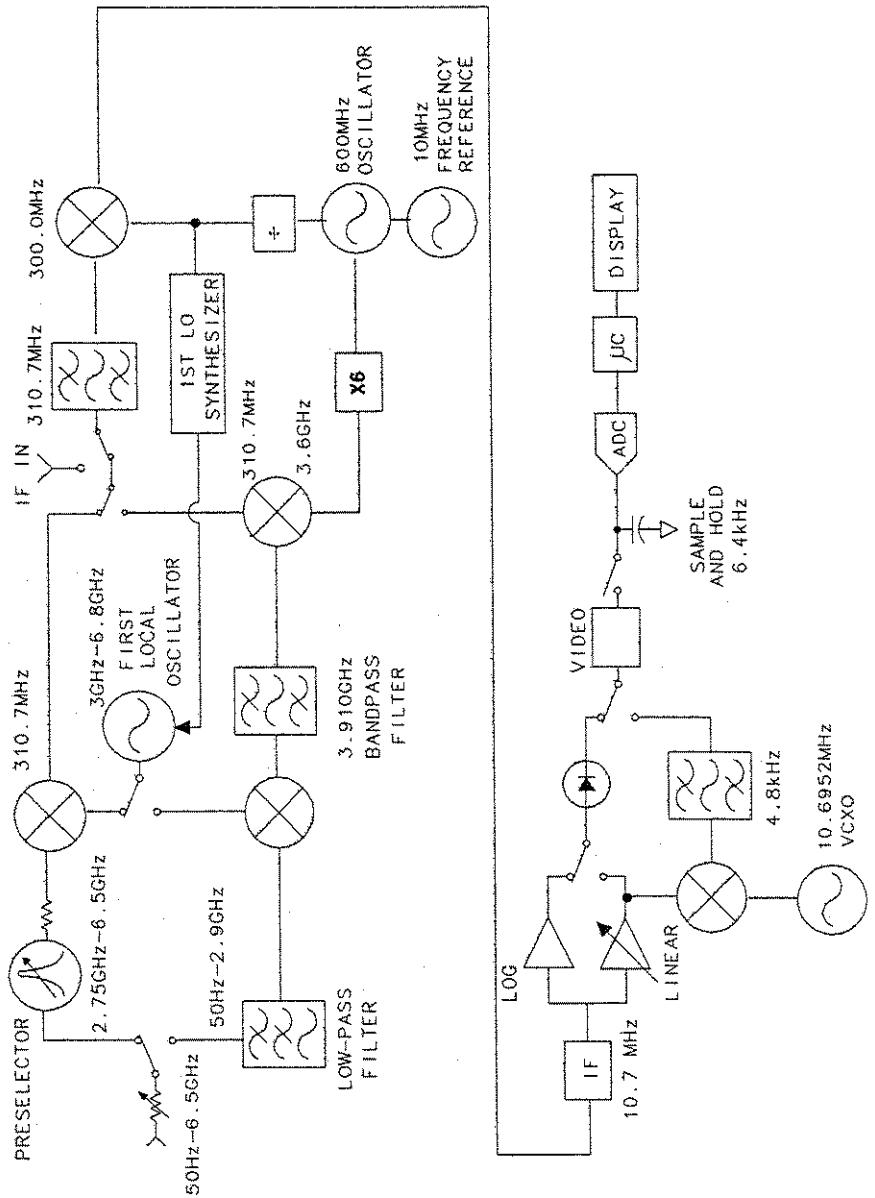

HP 8561B Block Diagram

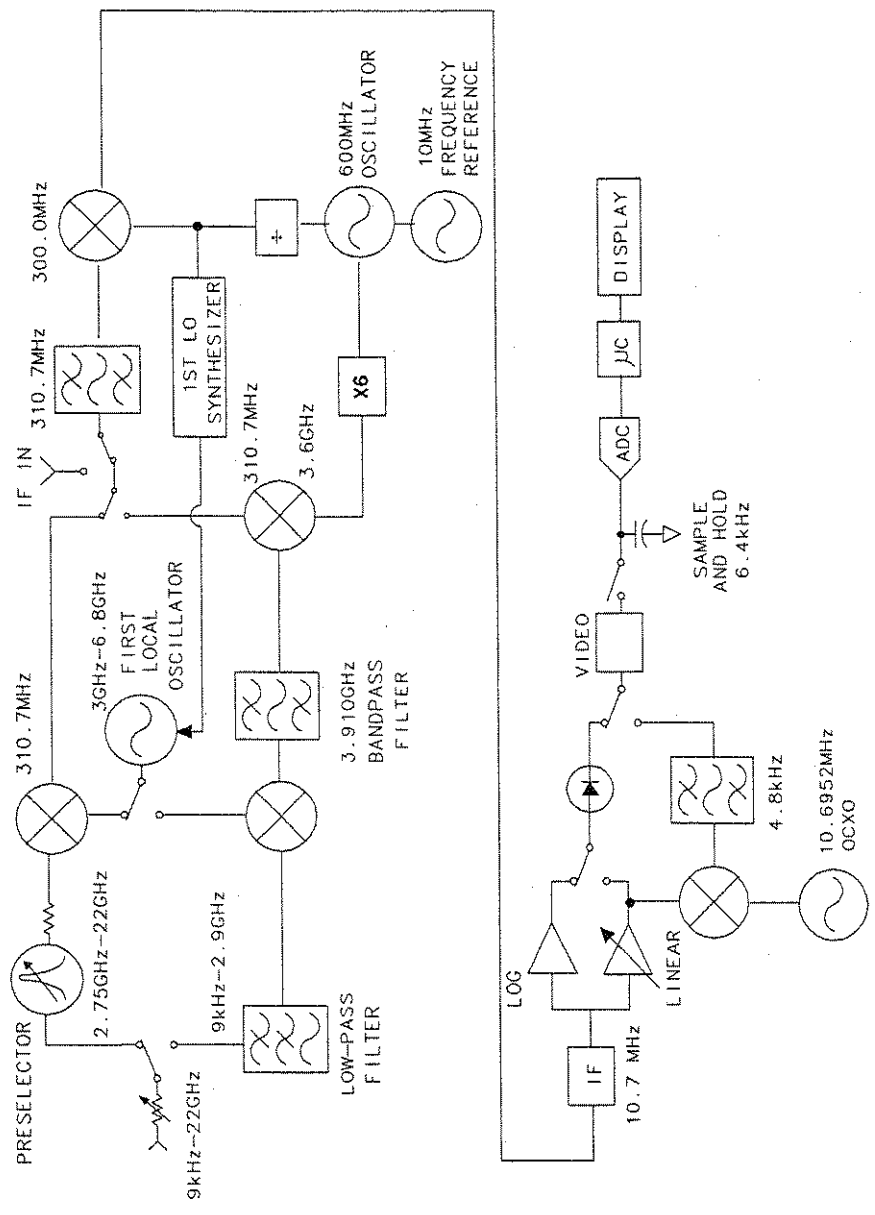

HP 8563A Block Diagram

F-4 Block Diagrams

